

Installation Guide

XB mounting bracket (supporting bolts version) XB51H/L / XB60 SB / XB61H/M/L

1

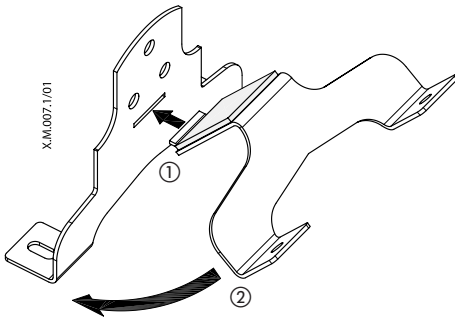

2

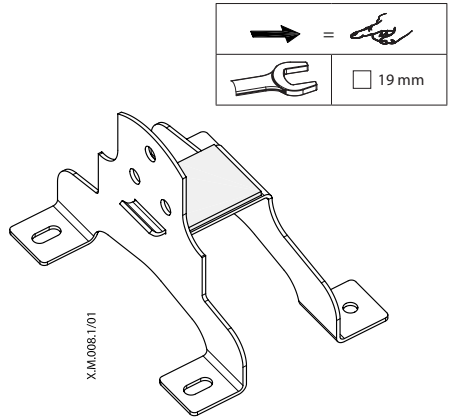

Code No.:

004B1788 XB51SB: 30-60pl.; XB61:H30-90;M30-70;L30-60

004B1789 XB51SB: 70-100pl.; XB60 SB 70-100pl;
XB61:H91-180;M71-160;L61-120

004B1790 XB51SB: 110-120pl.; XB60 SB 110-160pl;
XB61:H181-200;M161-200;L121-200

3

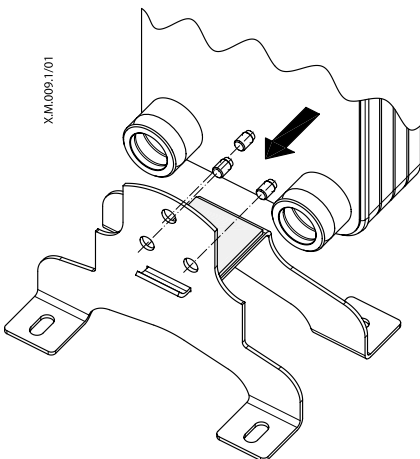

4

