

Data sheet

Liquid Distributor Type RD



The RD refrigerant distributors distribute liquid refrigerants from the thermostatic expansion valve to individual sections of the evaporator.

Note!

The thermostatic expansion valve must have external pressure equalization.

Features

- A wide range of RD refrigerant distributors is available, covering the majority of customer demands.
- RD design ensures a uniform distribution of refrigerant to each evaporator section.
- Suitable for refrigerants R22, R134a, R404A, R407C, R507, R410A. Concerning other refrigerants please contact Danfoss.
- Maximum working pressure: MWP/PS 48 bar/700 psig.

avrorarm.ru
+7 (495) 956-62-18

Application example

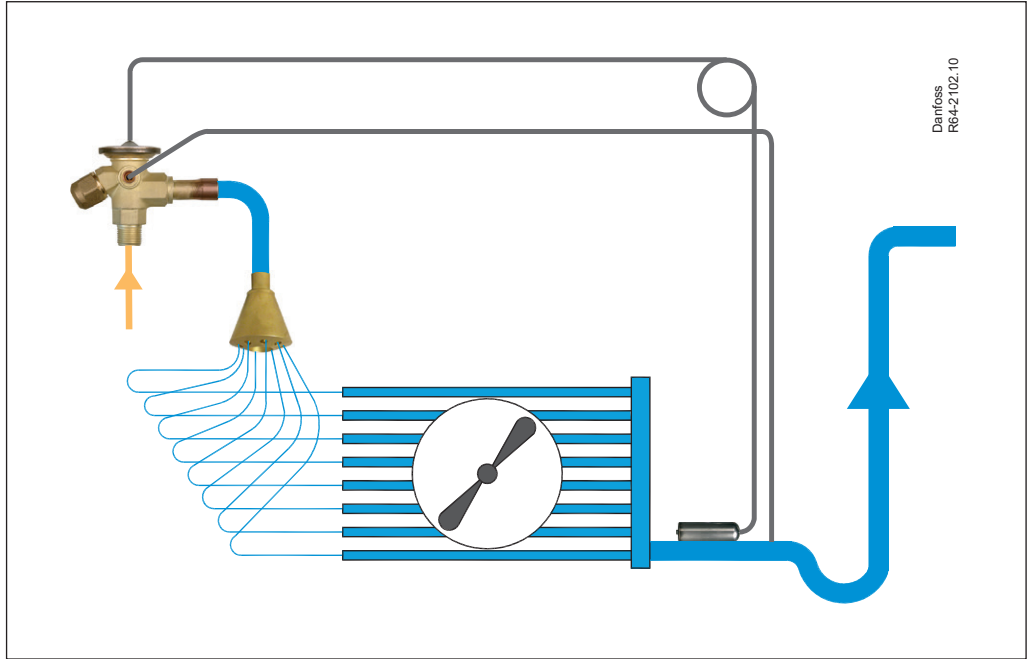

Design

RD, flare

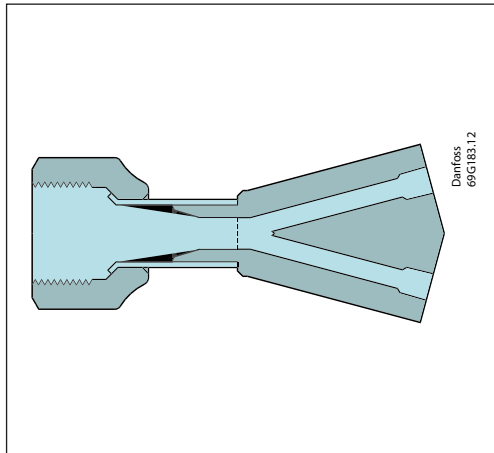

RD, solder ODM

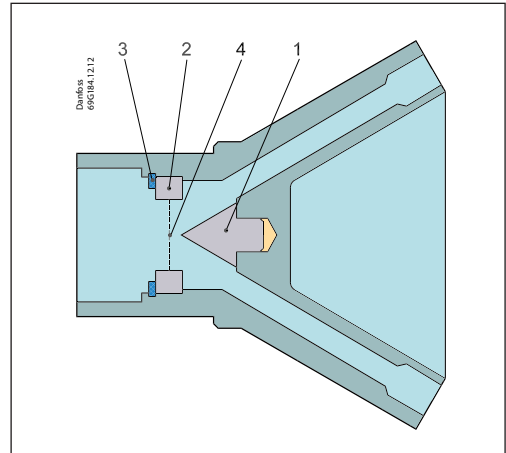

- 1. Cone
- 2. Nozzle
- 3. Locking ring
- 4. Nozzle diameter

Capacity

Table 1. Capacity in kW for 1 m distributor tube with $\Delta p = 0.5$ bar

Evaporating temperature t_e [°C]	Outer diameter of distributor tubes															
	$3/16$ in. / 5 mm				$1/4$ in. / 6 mm				$5/16$ in. / 8 mm				$3/8$ in. / 10 mm			
	R22 / R407C	R134a	R404A / R507	R410A	R22 / R407C	R134a	R404A / R507	R410A	R22 / R407C	R134a	R404A / R507	R410A	R22 / R407C	R134a	R404A / R507	R410A
10	2.4	2.1	1.9	2.6	5.1	4.2	3.8	5.6	9.7	8	7.2	10.7	15.8	13.1	12	17.4
5	2.2	1.8	1.6	2.4	4.5	3.7	3.4	5.0	8.5	7	6.4	9.4	14	11.6	10.6	15.4
0	1.9	1.6	1.5	2.1	4	3.3	3	4.4	7.4	6.1	5.6	8.1	12.3	10.1	9.3	13.5
-5	1.6	1.3	1.3	1.8	3.4	2.8	2.6	3.7	6.4	5.3	4.6	7.0	10.6	8.7	8	11.7
-10	1.4	1.2	1.1	1.5	2.9	2.4	2.2	3.2	5.5	4.5	4.2	6.1	9.1	7.4	6.9	10
-15	1.2	0.99	0.93	1.3	2.4	2	1.9	2.6	4.7	3.8	3.5	5.2	7.7	6.3	5.8	8.5
-20	0.99	0.87	0.76	1.1	2.1	1.7	1.6	2.3	4	3.3	3	4.4	6.5	5.4	5	7.2
-25	0.87	0.7	0.64	0.96	1.7	1.5	1.3	1.9	3.3	2.7	2.5	3.6	5.6	4.5	4.2	6.2
-30	0.7	0.58	0.52	0.77	1.5	1.2	1.1	1.7	2.8	2.3	2.1	3.1	4.7	3.8	3.5	5.2
-35	0.58	0.47	0.47	0.64	1.2	0.99	0.93	1.3	2.3	1.9	1.7	2.5	3.9	3.1	2.9	4.3
-40	0.52	0.41	0.41	0.57	1.1	0.87	0.81	1.2	2	1.7	1.5	2.2	3.3	2.7	2.5	3.6
-45	0.47	0.35	0.35	0.52	0.87	0.76	0.7	0.96	1.7	1.4	1.3	1.9	2.8	2.3	2.2	3.1
-50	0.41	0.29	0.29	0.45	0.76	0.64	0.6	0.84	1.5	1.2	1.1	1.7	2.4	2	1.9	2.6
-55	0.35	0.23	0.23	0.39	0.64	0.52	0.52	0.70	1.3	1	0.93	1.4	2.2	1.7	1.6	2.4
-60	0.29	0.2	0.18	0.32	0.52	0.47	0.47	0.57	1.2	0.81	0.76	1.3	1.9	1.4	1.5	2.1

Table 2. Correction factor for tube length

Tube length [mm]	250	400	550	700	850	1000	1150	1300	1450	1600	1750
Correction Factor	1.55	1.29	1.19	1.11	1.05	1.00	0.95	0.90	0.87	0.84	0.78

Table 3. Correction factor for liquid temperature

Liquid temperature [°C]	10	15	20	25	28	30	35	40	45	50
Correction factor	1.59	1.40	1.24	1.09	1.00	0.95	0.82	0.71	0.61	0.52

Capacity
(continued)

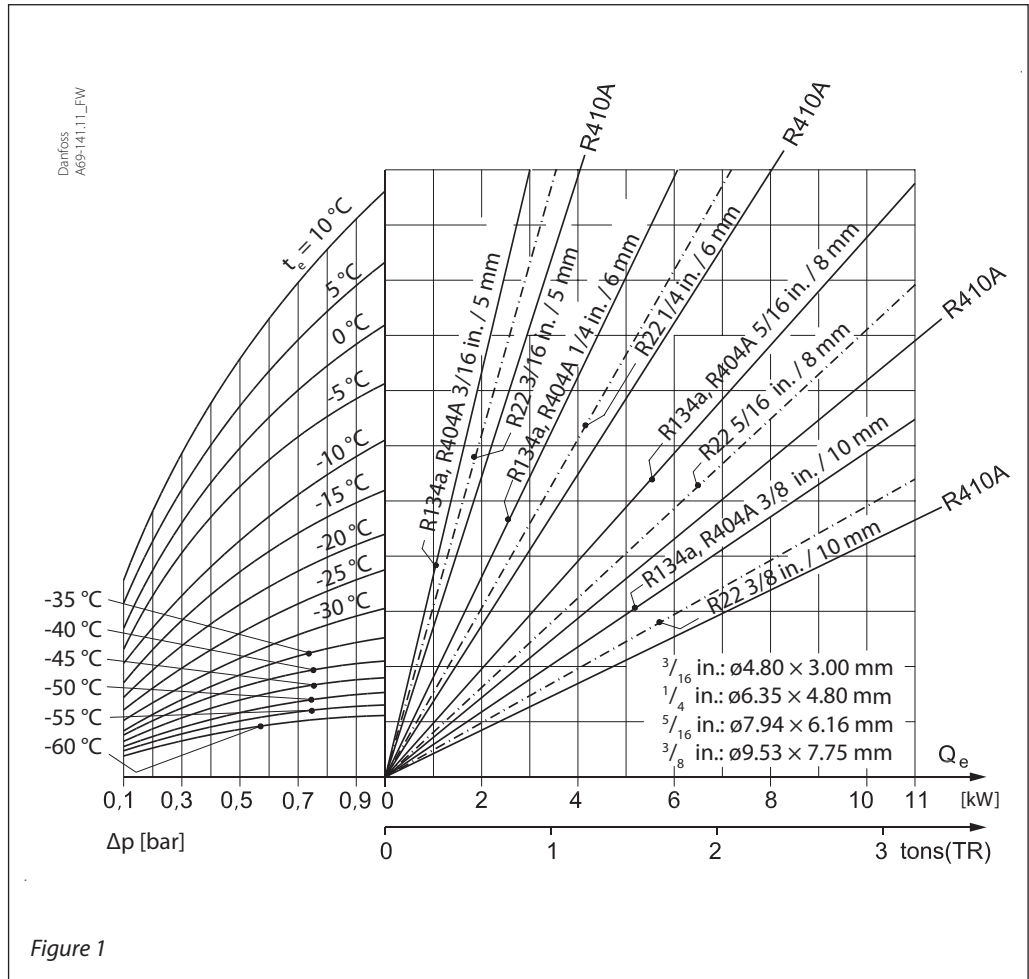

Figure 1

It is recommended that distributor tubes are sized for a pressure drop of approx. 0.5 bar. Table 1, which gives the capacities for different tube sizes, is based on this pressure drop.

Figure 1 shows the relation between evaporator capacity Q_e , refrigerant, tube diameter, evaporating temperature t_e and pressure drop Δp for 1 m distributor tube.

For tube lengths exceeding 1 m, tubes should be selected with larger diameters than indicated in table 1.

Ordering

Table 4

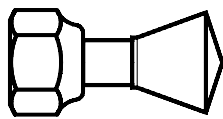

RD, flare

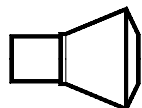

RD, solder

Distributor type	Distributor inlet	Rated capacity of expansion valves (R407C)	Max. number of holes and size of distributor outlet (ODF)			
			³ / ₁₆ in. / 5 mm	¹ / ₄ in. / 6 mm	⁵ / ₁₆ in. / 8 mm	³ / ₈ in. / 10 mm
RD 21	¹ / ₂ in. flare	≤ 25 kW (7 TR)	4	3	—	—
RD 27	¹ / ₂ in. flare	≤ 25 kW (7 TR)	6	5	—	—
RD 21	¹ / ₂ in. / 12 mm solder ODM	≤ 25 kW (7 TR)	4	3	—	—
RD 27	¹ / ₂ in. / 12 mm solder ODM	≤ 25 kW (7 TR)	6	5	—	—
RD 33	¹ / ₂ in. flare	≤ 35 kW (10 TR)	9	6	—	—
RD 33	¹ / ₂ in. / 12 mm solder ODM	≤ 35 kW (10 TR)	9	6	—	—
RD 42	¹ / ₂ in. / 12 mm solder ODM	≤ 35 kW (10 TR)	13	9	—	—
RD 33	⁵ / ₈ in. flare	≤ 35 kW (10 TR)	8	6	4	—
RD 33	⁵ / ₈ in. / 16 mm solder ODM	≤ 35 kW (10 TR)	8	6	4	—
RD 42	⁵ / ₈ in. / 16 mm solder ODM	≤ 35 kW (10 TR)	13	9	7	—
RD 49	⁵ / ₈ in. / 16 mm solder ODM	≤ 85 kW (25 TR)	17	14	10	—
RD 49	⁷ / ₈ in. / 22 mm solder ODM	≤ 85 kW (25 TR)	17	14	10	—
RD 62	⁷ / ₈ in. / 22 mm solder ODM	≤ 120 kW (35 TR)	—	18	14	—
RD 79 ¹⁾	1 ¹ / ₈ in. / 28 mm solder ODM	≤ 250 kW (70 TR)	—	24	19	15
RD 85 ¹⁾	1 ¹ / ₈ in. / 28 mm solder ODM	≤ 300 kW (85 TR)	—	27	22	18
RD 85 ¹⁾	1 ³ / ₈ in. / 35 mm solder ODM	≤ 300 kW (85 TR)	—	27	22	18

¹⁾ Replaceable nozzle, for nozzles with other diameters, see table 5

Table 5. Standard nozzle size

Distributor type	Nozzle diameter ¹⁾ [mm]
RD 21	5.0
RD 27	5.0
RD 33	6.0
RD 42	6.0
RD 49	8.0
RD 62	9.0
RD 79	8.0
RD 79	10.1
RD 79	12.4
RD 79	14.3
RD 85	17.5
RD 85	18.5

¹⁾ The optimum nozzle diameter depends on the plant conditions.

Table 6. Rated capacity correction factor depending on refrigerant (for use in conjunction with table 4)

Refrigerant	Correction factor
R407C	1.00
R22	0.92
R134a	0.72
R507	0.68
R404A	0.68
R410A	1.14

Type nomenclature

Table 7

Type	RD	Refrigerant Distributor
Body	21	ø21 mm
	27	ø27 mm
	33	ø33 mm
	42	ø42 mm
	49	ø49 mm
	79	ø79 mm
	85	ø85 mm
Inlet connector	A	12 mm solder ODM
	B	16 mm solder ODM
	C	22 mm solder ODM
	D	28 mm solder ODM
	E	35 mm solder ODM
	H	1/2 in. solder ODM
	J	5/8 in. solder ODM
	K	7/8 in. solder ODM
	L	1 1/8 in. solder ODM
	M	1 3/8 in. solder ODM
	P	1/2 in. flare F
	Q	5/8 in. flare F
Nozzle size	##	mm
Outlet connector	A	5 mm solder ODF
	B	6 mm solder ODF
	C	8 mm solder ODF
	D	10 mm solder ODF
	H	3/16 in. solder ODF
	J	1/4 in. solder ODF
	K	5/16 in. solder ODF
	L	3/8 in. solder ODF
Number of holes	##	2 – 27

Example of a type code:

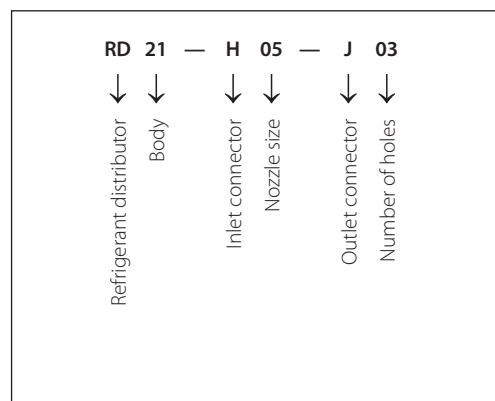

Selection of refrigerant distributor

The following data must be known:

1. Refrigerant
2. Evaporator capacity
3. Evaporating temperature
4. Liquid temperature
5. Number of evaporator sections
6. Evaporator section inlet size
7. Distributor tube length
8. Expansion valve type

It is then possible to determine:

1. *Size of distributor tubes*

The capacity of the individual distributor tube is calculated by dividing the total evaporator capacity by the number of uniform evaporator sections. The tube diameter can then be determined from table 1 or figure 1.

Sizing should be based on the average capacity of the evaporator.

A sufficiently uniform distribution can be expected at capacities of between 40% and 125% of the values given in table 1.

Example

Given data:

1. Refrigerant: R404A
2. Evaporator capacity Q_e : 20 kW
3. Evaporating temperature t_e : -15 °C
4. Liquid temperature T_l : 20 °C
5. Number of evaporator sections: 10
6. Evaporator section inlet size: 6 mm
7. Distributor tube length: 850 mm
8. Expansion valve with 22 mm ODF solder connection on outlet side

The capacity of each individual distributor tube is $20 / 10 = 2.0$ kW.

Table 1 shows that with an evaporating temperature of -15 °C and R404A, a $\varnothing 6$ mm tube with a length of 1 meter will yield 1.9 kW.

Correction factors for tube length and liquid temperature are found in tables 2 and 3.

For a tube length of 850 mm, the correction factor is 1.05. For a liquid temperature of 20 °C, the correction factor is 1.24.

Under the given conditions, the distributor tubes yield $1.9 \times 1.24 \times 1.05 = 2.47$ kW.

The actual load, as a percentage of the listed rating, is thus $2.0 / 2.47 = 0.81$ or 81%.

The type of distributor, inlet size and type are determined from table 4.

There are two options: RD 49 or RD 62.

The rated capacity of the expansion valve can be found using table 6 together with table 4:

- RD 49: $85 \times 0.68 = 58$ kW
- RD 62: $120 \times 0.68 = 82$ kW

Both distributors can be used, but RD 49 is selected because the rated capacity is closer to the evaporator capacity.

The standard nozzle diameter is determined from table 5: 8 mm.

The required distributor type is determined from table 7: RD49-C08-B10.

Please contact Danfoss for the code number.

Dimensions [mm]
and weights [kg]

RD, flare

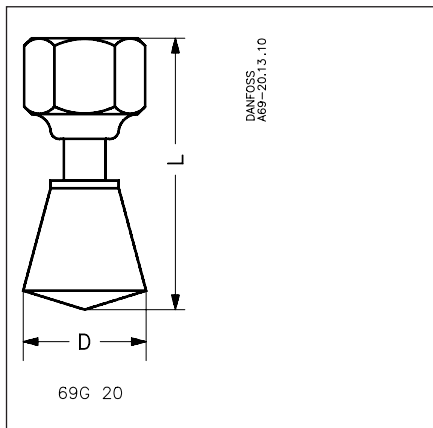

RD, solder ODM

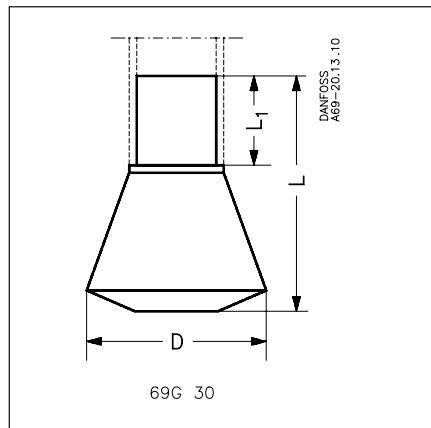

Table 8

Distributor type	Distributor inlet	L	L ₁	D	Approx. net weight	Industrial pack
RD 21	Flare	55	—	21	0.1	24
RD 21	Solder	31	10	21	0.1	24
RD 27	Flare	65	10	27	0.1	24
RD 27	Solder	41	10	27	0.1	24
RD 33	Flare (1/2 in.)	71	—	33	0.2	24
RD 33	Solder (1/2 in. / 12 mm)	50	12	33	0.2	24
RD 33	Flare (5/8 in.)	76	—	33	0.2	24
RD 33	Solder (5/8 in. / 16 mm)	50	17	33	0.2	24
RD 42	Solder	52	12	42	0.2	15
RD 49	Solder (5/8 in. / 16 mm)	62	17	49	0.3	15
RD 49	Solder (7/8 in. / 22 mm)	62	24	49	0.3	15
RD 62	Solder	66	24	62	0.7	9
RD 79	Solder	81	25	79	0.9	6
RD 85	Solder	81	30	85	0.9	6

Danfoss can accept no responsibility for possible errors in catalogues, brochures and other printed material. Danfoss reserves the right to alter its products without notice. This also applies to products already on order provided that such alterations can be made without subsequential changes being necessary in specifications already agreed. All trademarks in this material are property of the respective companies. Danfoss and the Danfoss logotype are trademarks of Danfoss A/S. All rights reserved.