

avrrora-arm.ru  
+7 (495) 956-62-18

ENGINEERING  
TOMORROW

*Danfoss*

Service guide

## APP pumps

APP 11-13 and APP 16-22

Disassembling and assembling



**Table of Contents**

**Contents**

1. Introduction ..... 2

2. Disassembling the pump ..... 3

3. Assembling the pump ..... 6

4. Disassembling and assembling of the swash plate ..... 11

5. Disassembling and assembling of cylinder barrel and valve plate ..... 12

6. Disassembling and assembling of the flush valve ..... 12

7. Changing pistons ..... 13

8. Assembling ..... 15

9. When should the pistons be replaced? ..... 17

10. Exploded view APP 11-13 ..... 18

11. Exploded view APP 16-19 ..... 19

12. Exploded view APP 22 ..... 20

**This document covers the instructions for disassembling and assembling the axial piston pumps APP 11-13 and APP 16-22.**

**1. Introduction**

**Tools provided with toolset 180B4222:**

- 10 mm combination wrench
- 13 mm combination wrench
- 6 mm allen key
- Adjustable pin wrench
- Stop for retainer plate
- Press bush for valve plate
- Extractor
- M8x20 mm allen screw
- Press bush (Plastic)
- M8 mm eye bolt
- M8 mm nut
- M8 x 70 mm screw

Place the pump on a pallet or other stable surface above the ground. Ensure that the pump cannot roll. It must be possible to place the pump vertically with the shaft pointing downwards. This can be done between two pallets or between two boards on a pallet provided that the distance is minimum 100 mm.

For a better understanding of the pump, please see the exploded view on page 18, 19 and 20.

**WARNING:**  
**Do not reuse disassembled O-rings or shaft seal as they might be damaged. Always use new O-rings.**

**Important: It is essential that the pump is serviced in conditions of absolute cleanliness.**



## 2. Disassembling the pump



1. Disconnect the pump from the rest of the system.
2. Using a 10 mm combination wrench, unscrew the four bolts from shaft seal flange. If shaft seal flange is stuck, screw in two bolts in holes in the flange to remove it.

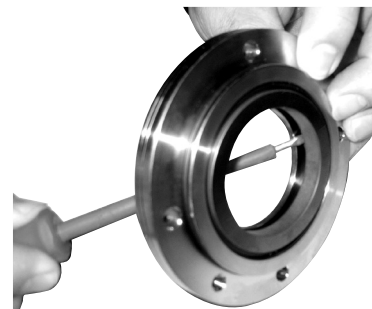

3. Remove ceramic ring from flange by carefully pushing it from the back of the sealing ring.



4. Mount the M8 allen screw from the tool set in the top of the shaft.
5. Wet the shaft and shaft seal with clean filtered water.



6. Carefully remove the shaft seal assembly using the shaft seal extractor supplied in the toolset. The extractor must fit underneath the shaft seal. Press the arms of the extractor together when turning the bolt.



7. Turn pump into vertical position with shaft pointing downwards. Ensure minimum 100 mm (3,94 inch) free space for the shaft.

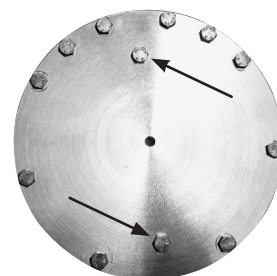

8. Using a 13 mm combination wrench, remove all the bolts on the mounting flange except the three shown in the next picture.

**WARNING:**  
Do not loosen the two screws keeping swash plate in place.

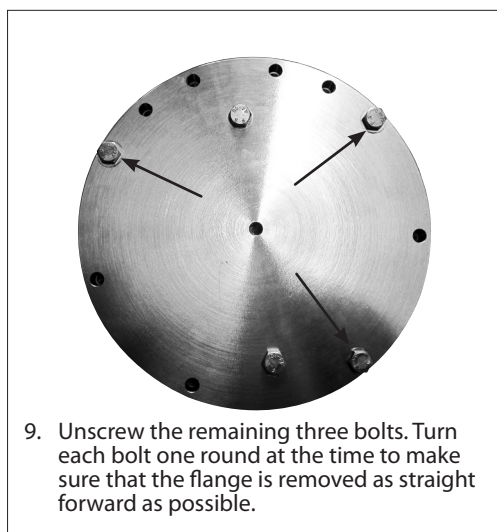

9. Unscrew the remaining three bolts. Turn each bolt one round at the time to make sure that the flange is removed as straight forward as possible.

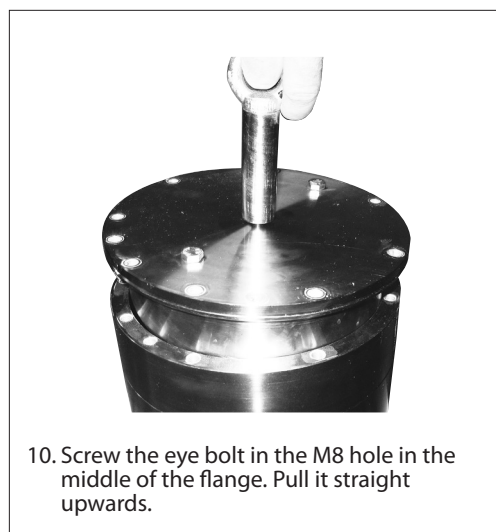

10. Screw the eye bolt in the M8 hole in the middle of the flange. Pull it straight upwards.



11. Swash plate must be placed so that its surface is not scratched. For further disassembling of swash plate, see page 11.

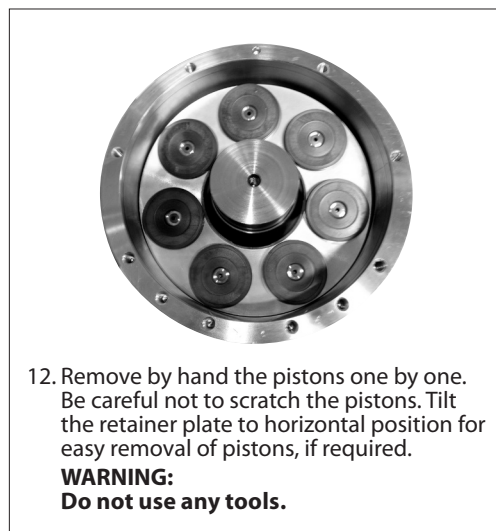

12. Remove by hand the pistons one by one. Be careful not to scratch the pistons. Tilt the retainer plate to horizontal position for easy removal of pistons, if required.  
**WARNING:**  
**Do not use any tools.**



13. Remove the retainer plate and the retainer ball.  
**Note: As the retainer ball is not attached to the retainer plate, it might fall out.**

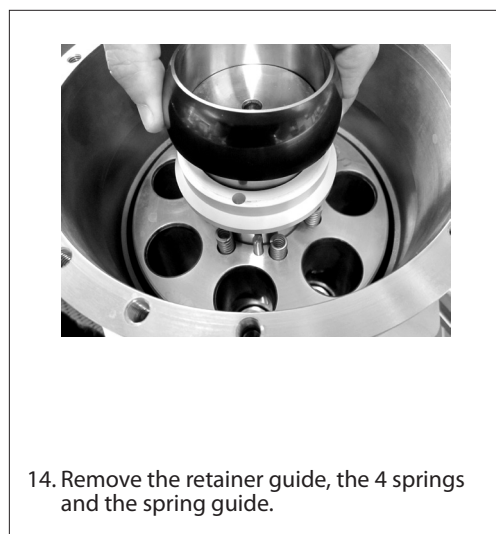

14. Remove the retainer guide, the 4 springs and the spring guide.





15. Mount a 8 mm eye bolt in the cylinder barrel. Pull straight upwards. A continuous lift will elevate the cylinder barrel out of housing. This can only be done if shaft seal is removed.

**WARNING:**  
**If the cylinder barrel is dropped or lowered too fast into housing, the main bearing/shaft bearing might be damaged. It is not replaceable.**



16. Place cylinder barrel upside down. For further disassembling of cylinder barrel and valve plate see page 12.

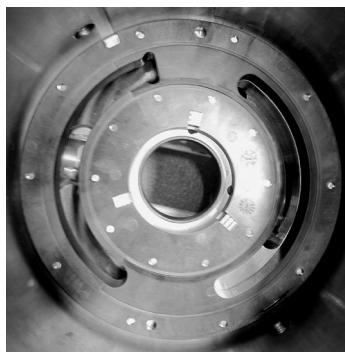

17. Remove the port plate by hand.

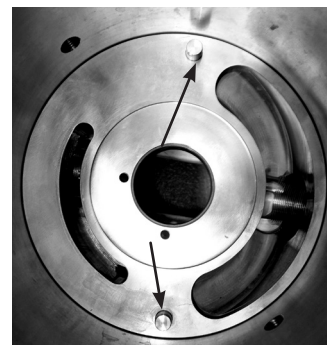

18. Remove, by hand, the two pins.  
**Note: The following operation is only necessary if O-ring on port flange is to be changed.**



19. Place the pump horizontally.  
 20. Remove the remaining screws in port flange by using a 13 mm combination wrench. Carefully separate house and port flange. Ensure that pin for the positioning house is not lost.

21. For further disassembling of flush valve, see page 12.

### 3. Assembling the pump

**WARNING:**  
Do not use silicone when assembling the pump. Do not reuse disassembled O-rings; they might be damaged. Always use new O-rings.

**Important:**  
It is essential that the pump is serviced in conditions of absolute cleanliness. All parts must be absolute clean before mounting.

**Note:**  
Place the pump on a pallet or other stable surface above the ground. Ensure that the pump cannot roll. It must be possible to place the pump vertically with the shaft pointing downwards. This can be done between two pallets or between two boards on a pallet provided that the distance is minimum 50 mm.



1. Lubrication:
  - To prevent seizing-up, lubricate all threads with PTFE lubrication type.
  - O-rings inside pump may be lubricated only with clean filtered water.
  - O-rings for port flange, mounting flange and flushing valve must be lubricated.
  - It is important to lubricate ALL parts to be assembled with clean filtered water (Especially all PEEK parts).

2. Place port flange with O-ring pointing upwards.



3. Insert guide pin for positioning housing on port flange. Ensure that two screw holes can be reached from below.



4. Mount the O-ring. Remember lubrication of the O-ring with clean filtered water.
5. Position housing by aligning pin hole over guide pin.
6. Gently press downwards. Be careful not to squeeze the O-ring. If O-ring is damaged the pump will leak.



7. Screw in at least two screws from below.

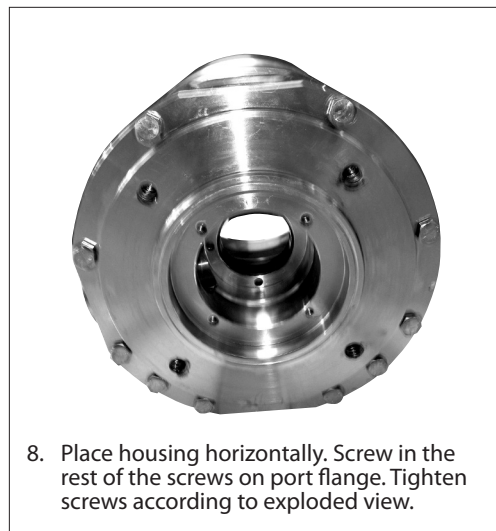

8. Place housing horizontally. Screw in the rest of the screws on port flange. Tighten screws according to exploded view.

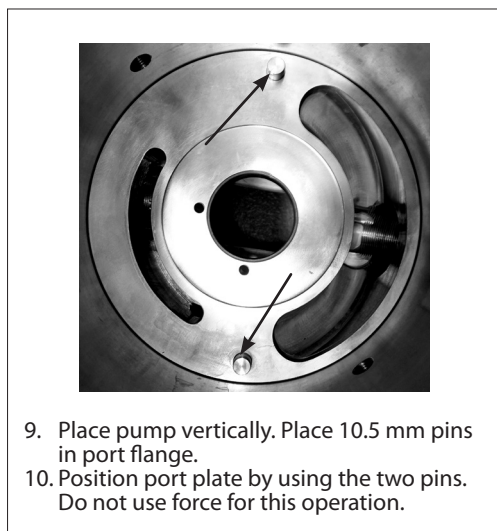

9. Place pump vertically. Place 10.5 mm pins in port flange.  
10. Position port plate by using the two pins. Do not use force for this operation.



11. Ensure port plate is fitted tightly against the bottom.  
**IMPORTANT:**  
**Lubricate port plate with clean filtered fresh water.**  
If valve plate is disassembled from cylinder barrel please see page 12 before continuing.  
12. Screw eye bolt in cylinder barrel.



13. Make sure there is enough free space for the shaft beneath the housing. Minimum 100 mm (3,94 inch). Carefully lower cylinder barrel into housing.

**WARNING!**  
**If cylinder barrel is dropped or lowered too fast into housing, main bearing and shaft bearing might be damaged. Replacement can only be done at Danfoss, Nordborg.**

14. Unscrew M8 eye bolt.



15. Place the 7 springs and 3 pins in cylinder barrel. The pin holes are assymetric.



16. Place the spring guide and the retainer guide on the cylinder shaft.



17. Place retainer plate in cylinder barrel.  
**Note: (Remember to lubricate the retainer plate and cylinder bushings with clean filtered water).**

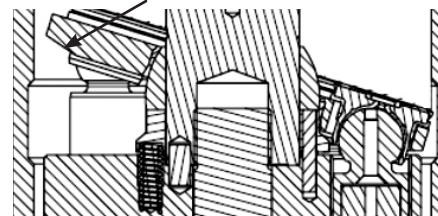

18. Ensure that retainer plate is oriented correctly, i.e. with its slant surfaces pointing downwards.



19. Place pistons in retainer plate and cylinder barrel, When pistons are placed, tilt retainer plate for easier placement of swash plate.  
If swash plate has been disassembled from mounting flange, see page 11 for assembly of swash plate.



20. Place the guide pin in the housing.  
21. Lubricate piston shoes and swash plate with clean filtered water.  
22. Mount assembled swash plate, using the guide pin.



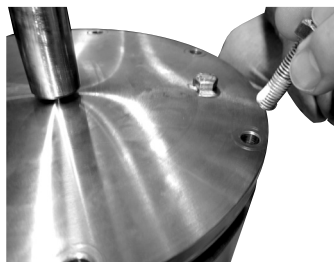

23. Place three bolts in mounting flange. (Remember lubrication as stated in paragraph 1 page 6.) Turn each bolt one round at a time to ensure mounting flange is mounted as straight downwards as possible. Be careful not to squeeze the O-ring.



24. Screw in the rest of the bolts and tighten all screws according to exploded view.



25. Place pump horizontally to get access to shaft.  
26. Lubricate shaft with clean filtered water.

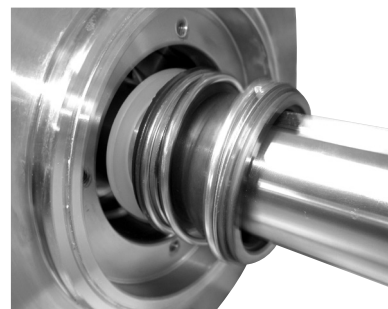

27. Place stop for shaft seal and new shaft seal on shaft.  
**WARNING: Ensure that carbon ring is pointing outwards. Do not reuse the shaft seal, due to risk of leakage.**

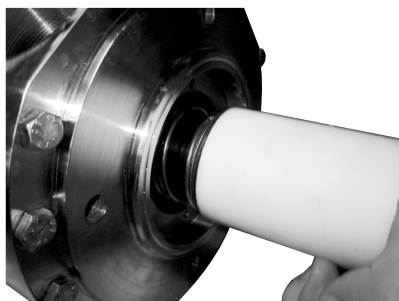

28. Use plastic press bush assembly tool provided with large diameter pointing towards seal, to press seal against shoulder of stop for shaft seal.



29. Press new ceramic ring into shaft seal flange, using plastic tool provided.  
**WARNING: Ensure that the face with rubber seal is positioned against shoulder in shaft seal flange. Ensure that ceramic ring is pointing outwards.**

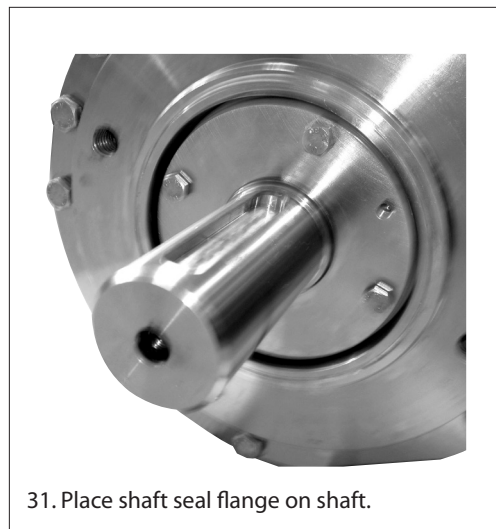

32. Tighten the bolts with a torque according to exploded view.

**4. Disassembling and assembling of the swash plate**

**WARNING:**  
**Make sure that the surface on the swash plate does not get any marks.**



1. Place the swash plate upside down. Remove the 2 bolts holding the swash plate. Remove the mounting flange from the swash plate.

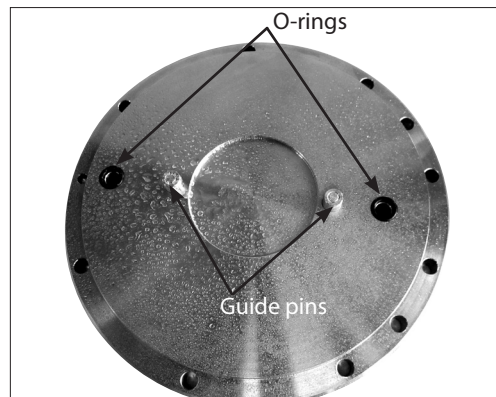

2. Check that the O-ring and pin are in good condition (Provided with sealing set).



3. Change the O-ring on the mounting flange.

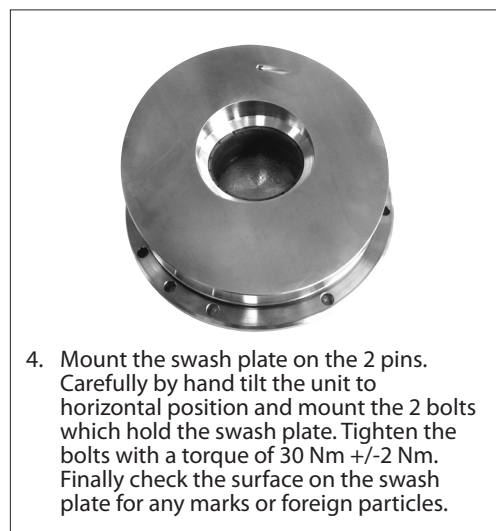

4. Mount the swash plate on the 2 pins. Carefully by hand tilt the unit to horizontal position and mount the 2 bolts which hold the swash plate. Tighten the bolts with a torque of 30 Nm +/- 2 Nm. Finally check the surface on the swash plate for any marks or foreign particles.

5. Mount the assembled part on the pump. (Remember to lubricate the O-ring).

**5. Disassembling and assembling of cylinder barrel and valve plate**

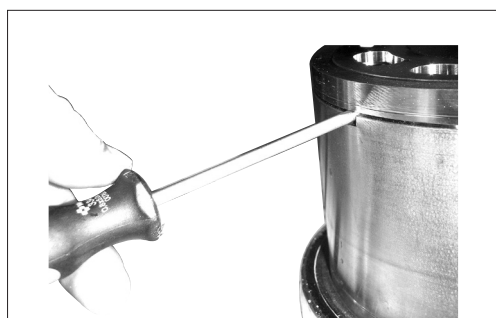

1. Push a screwdriver into the hole between cylinder barrel and valve plate. Carefully push downward the screwdriver so that it makes a gap between cylinder barrel and valve plate. Use this gap to put in another screwdriver and loosen the valve plate from the cylinder barrel.

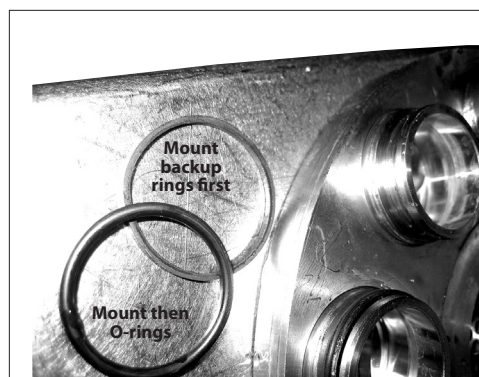

2. Remove the O-rings and backup rings. If they have been removed they can not be reused. Mount the new back-up rings on the valve plate first and then mount the O-rings.

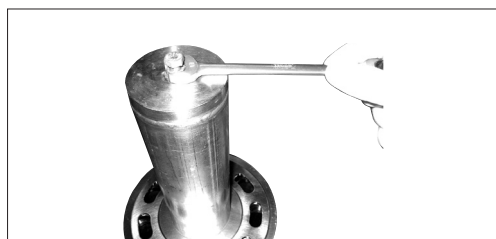

3. Lubricate the new O-rings/back-up rings and the liners in the cylinder barrel with clean filtered water. Lower the valve plate upside down on the cylinder barrel. Place the press bush for valve plate (provided in tool set) like on the picture. Screw the bolt into the shaft of the cylinder barrel. Turn the nut slowly clockwise. The valve plate must slide carefully into the cylinder barrel. Stop when the gap between cylinder barrel and valve plate is 1-2 mm.



4. Remove the press bush again by screwing the nut counter-clockwise. Turn the nut slowly clockwise. The valve plate must slide gently into the cylinder barrel. Stop when the gap between cylinder barrel and valve plate is 1-2 mm.

**6. Disassembling and assembling of the flush valve**



1. Unscrew the flush valve counter-clockwise by using a pin wrench.



2. Remove the O-rings (green and black). If necessary, change the valve cone, spring and plug. If the spring is changed it is important that it is located like on the picture. The end of the spring must be against the shoulder of the valve cone.

3. Put a little amount of grease on the thread on the plug. Screw it into the port flange. Tighten with a torque according to exploded view.



## 7. Changing pistons

Tools needed are:

- 13 mm combination wrench
- 6 mm allen key

Service kit see parts list 521B0941

**Note: It is essential that the pump is serviced in conditions of absolute cleanliness.**

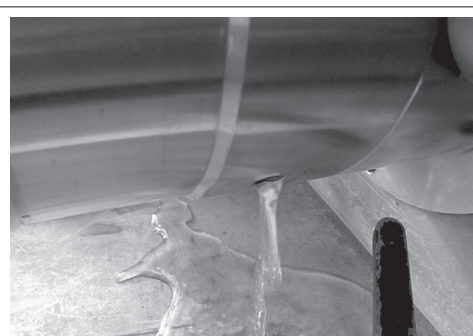

1. Disconnect the pump from the system, or close all connection pipes (water supply). Bleed water from the pump.

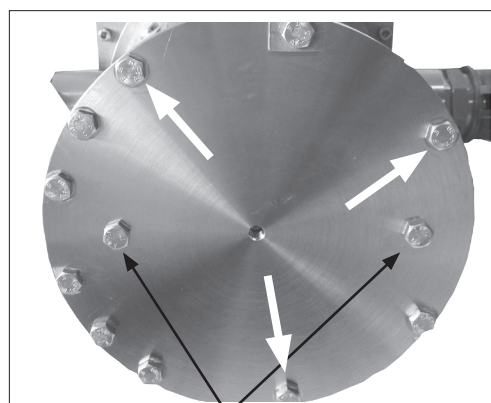

- Warning: Never unscrew the 2 screws marked with coloured sealer.**
2. Loosen all screws on the pump except the 3 screws as shown in the picture above, using the 13 mm combination wrench.

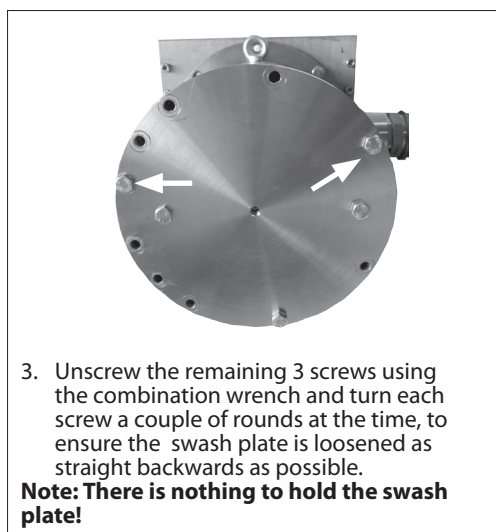

3. Unscrew the remaining 3 screws using the combination wrench and turn each screw a couple of rounds at the time, to ensure the swash plate is loosened as straight backwards as possible.

**Note: There is nothing to hold the swash plate!**



4. Remove the flange/swash plate carefully.



5. Place the swash plate upside down to avoid scratches on the surface.

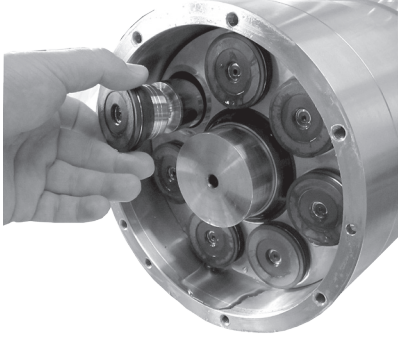

6. Carefully remove the pistons one by one.

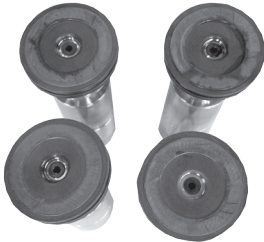

7. It is recommended to place the pistons upside down on an even clean base/ surface.

**Warning: Ensure that the piston shoes and piston surfaces are not damaged or scratched during removal.**

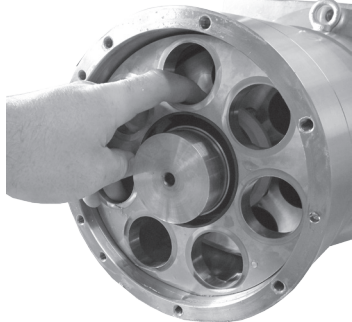

8. Remove the retainer plate.



9. Inspect the piston bushings in the cylinder barrel for scratches or othe damages. Small scratches are accepted if there are no hard particles in the bushings.

If any worn pistons are found, all pistons must be replaced. See page 17.

## 8. Assembling

**Important: It is essential that the pump is serviced in conditions of absolute cleanliness.**

**All parts must be absolute clean before mounting**

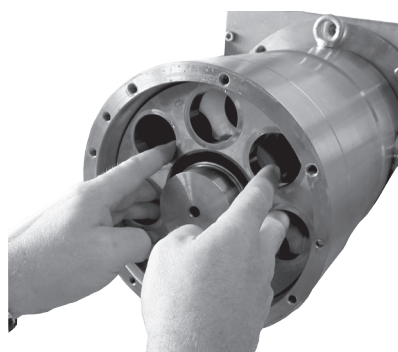

1. Carefully push the retainer plate in place.

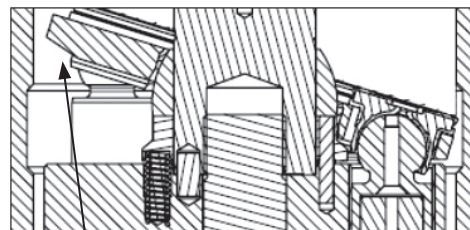

2. Ensure that the retainer plate is oriented correctly with its slant surfaces pointing downwards.

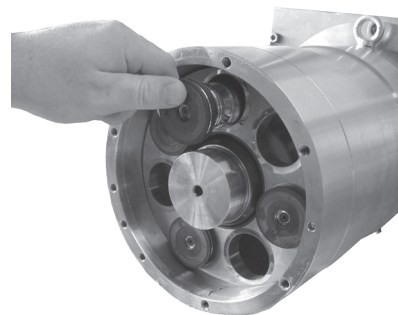

3. Insert all the pistons randomly.

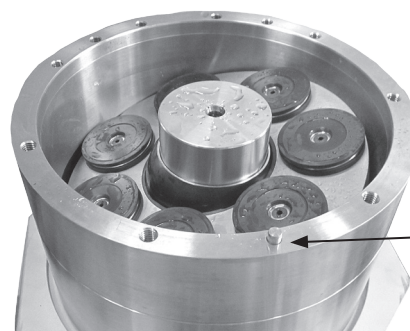

4. Tilt the retainer plate for easy insert of the swash plate. Place the pin in the housing.

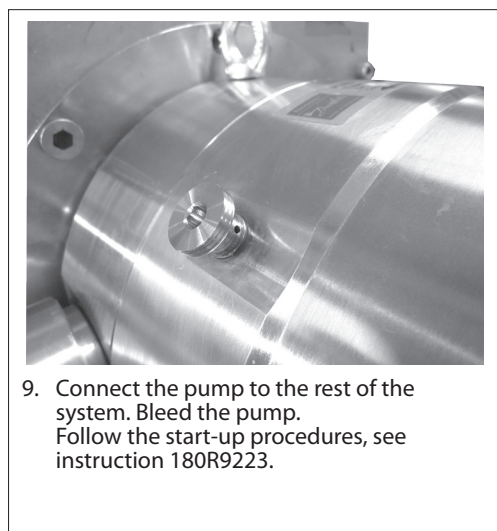
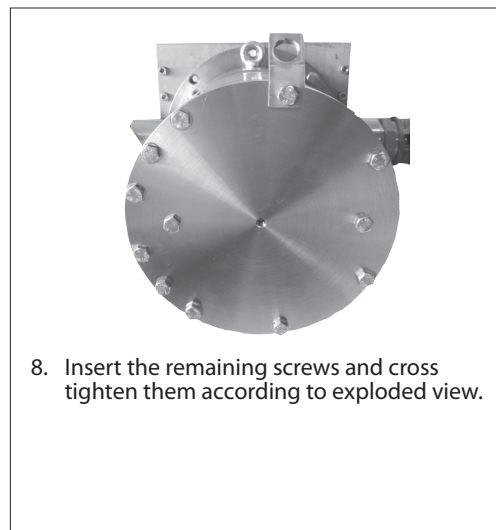
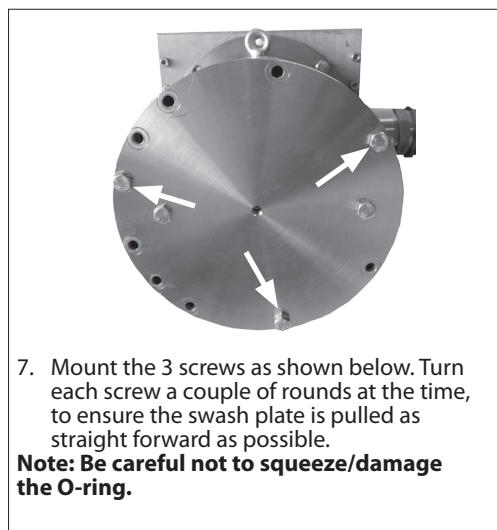
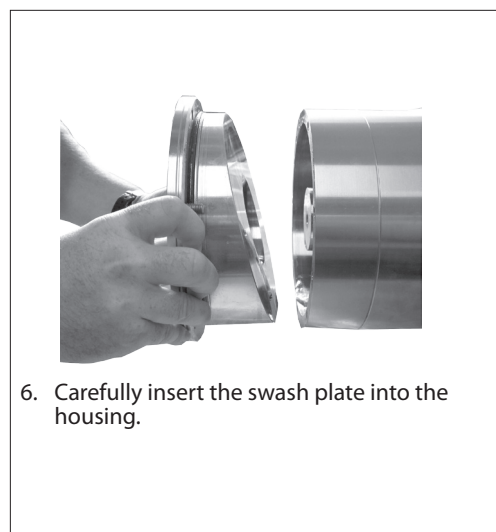



**9. When should the pistons be replaced?**

This section provides guides on how to determine whether the pistons of APP 11-13 and 16-22 are worn and should be replaced.

In case of doubt - the pistons must be replaced. If any worn pistons are found, all pistons must be replaced.

**Note: If the pistons break down, the pump will suffer a disastrous breakdown.**

The pictures below are meant as guideline for evaluating the wear of the sliding surface.W

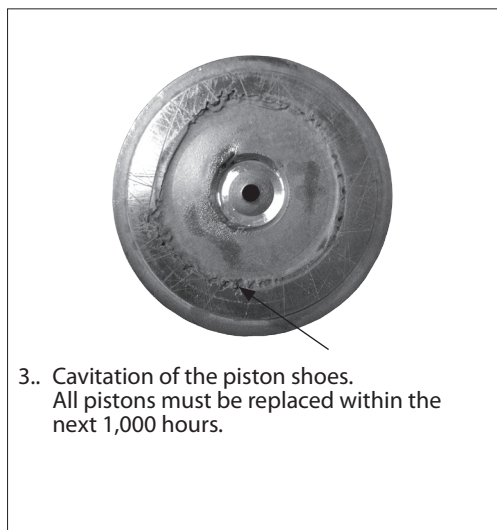

10. Exploded view  
APP 11-13

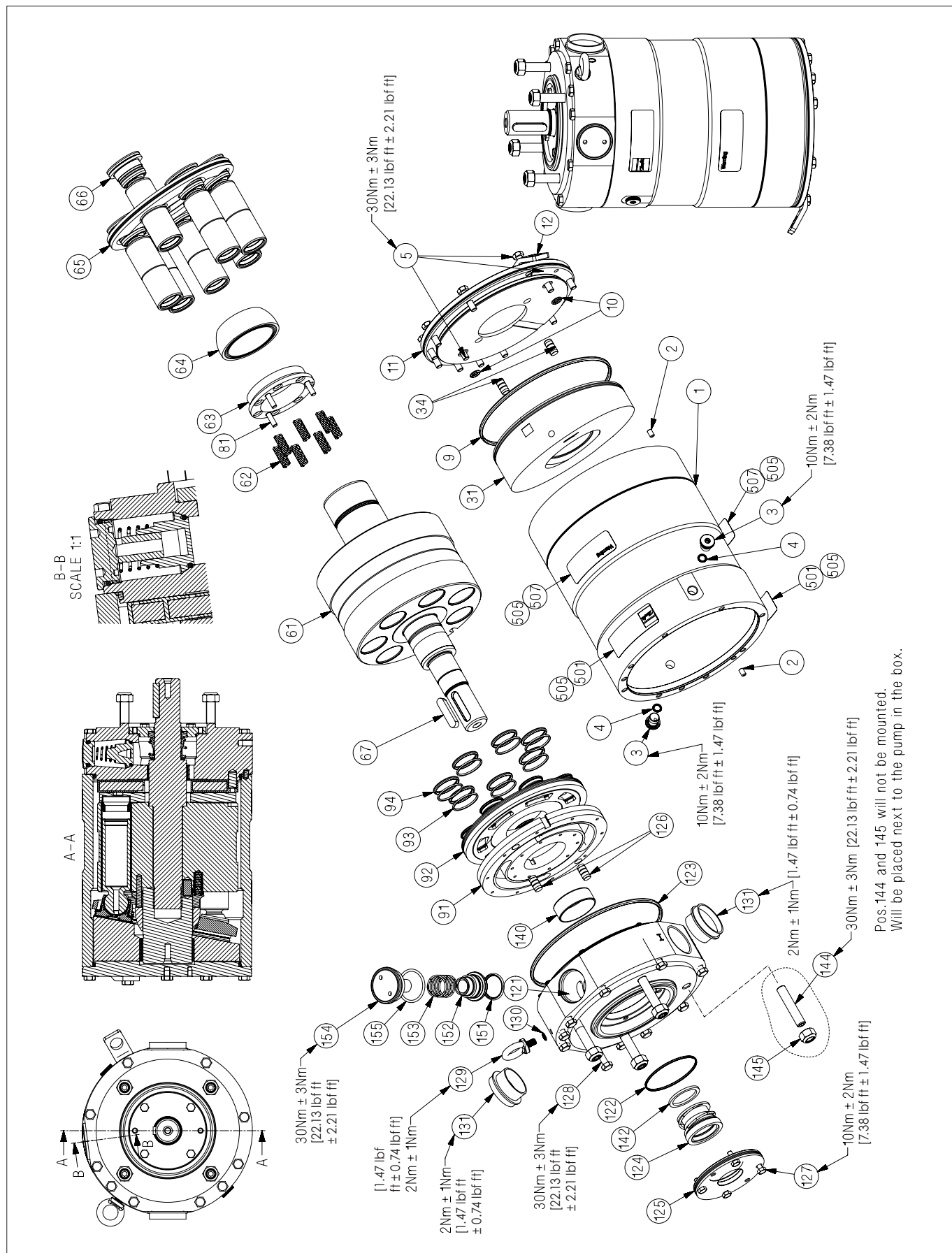

11. Exploded view  
APP 16-19

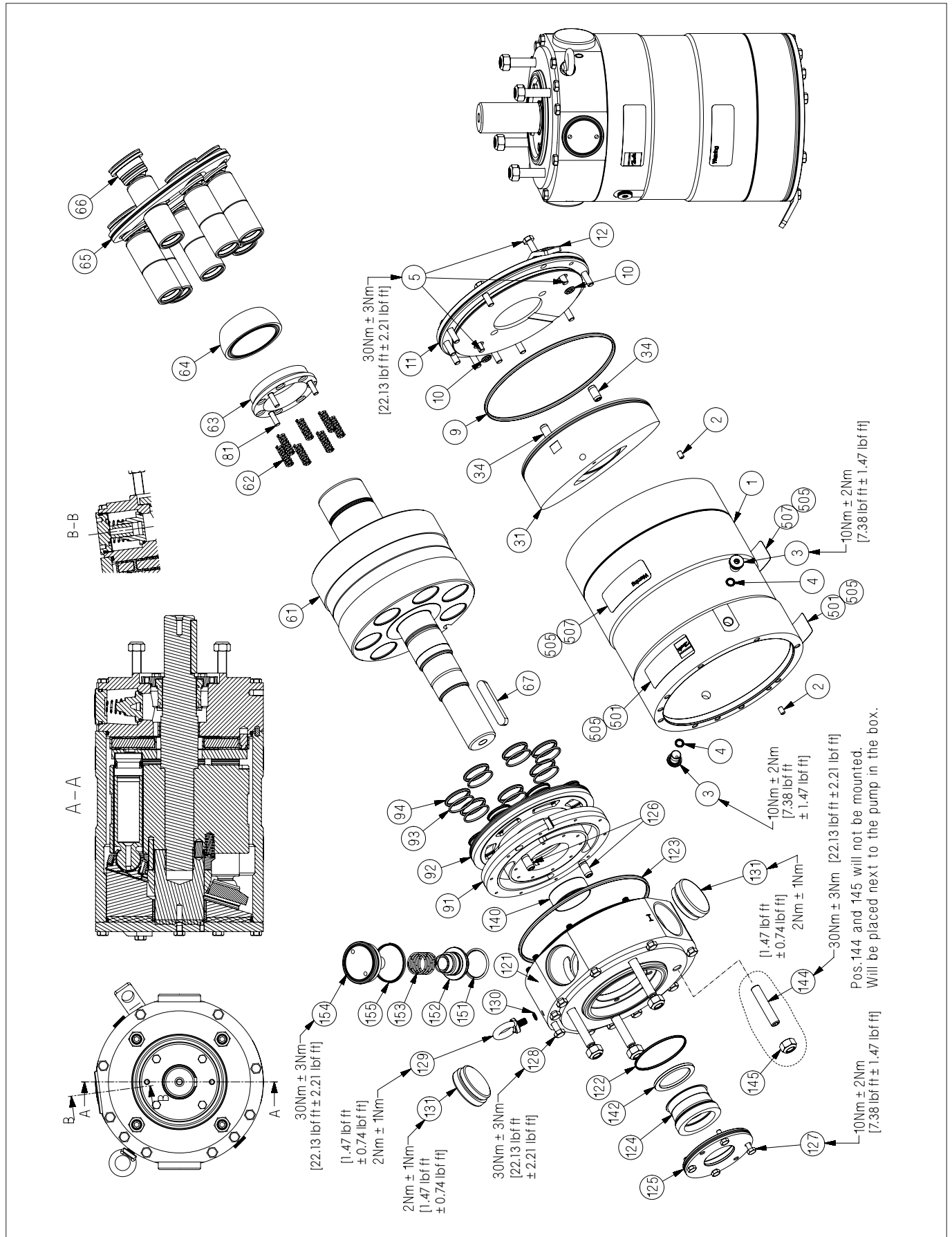

12. Exploded view  
APP 22

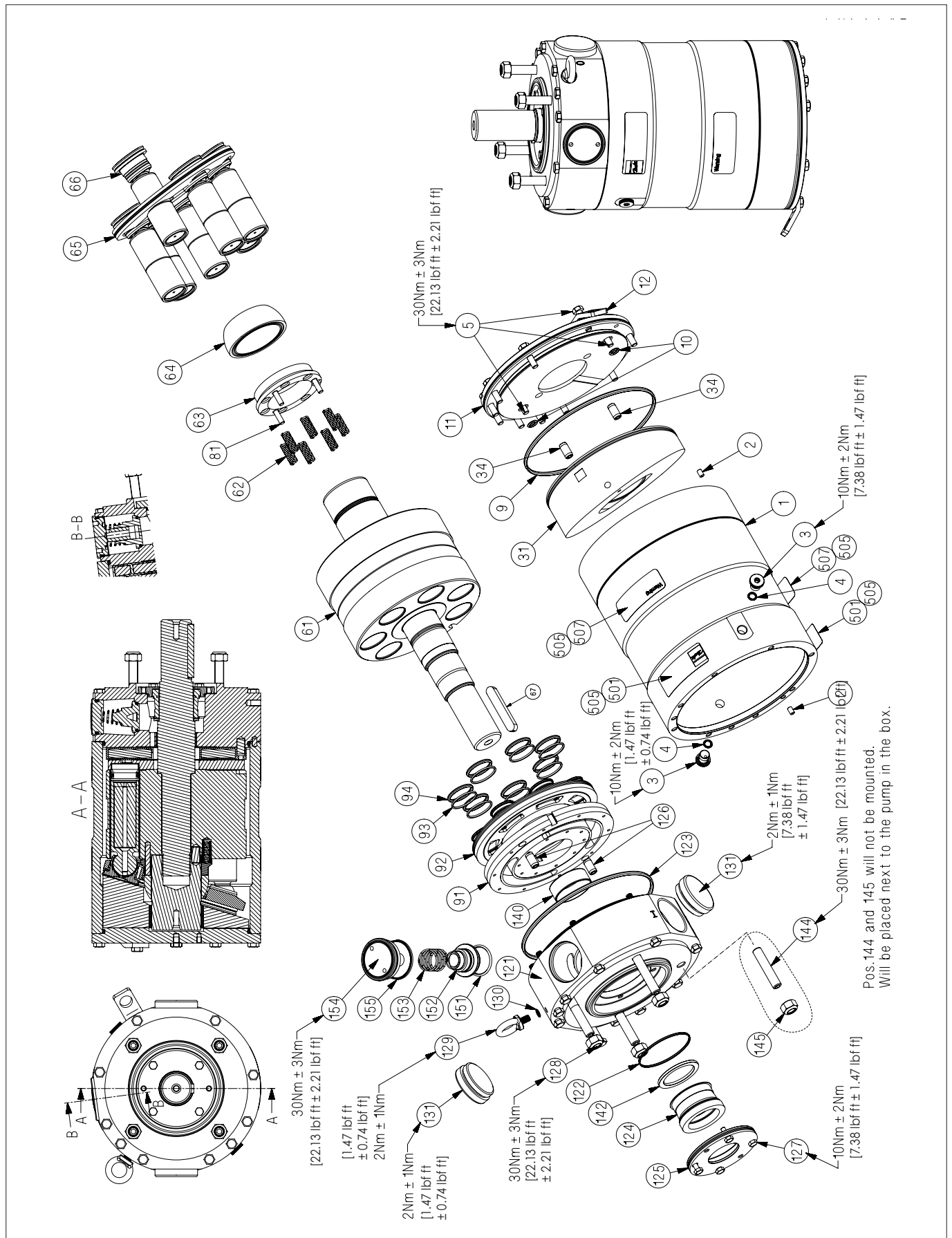



**avrora-arm.ru**  
**+7 (495) 956-62-18**

ENGINEERING  
TOMORROW



---

Danfoss can accept no responsibility for possible errors in catalogues, brochures and other printed material. Danfoss reserves the right to alter its products without notice. This also applies to products already on order provided that such alterations can be made without subsequential changes being necessary in specifications already agreed. All trademarks in this material are property of the respective companies. Danfoss and the Danfoss logotype are trademarks of Danfoss A/S. All rights reserved.

---