

Introduction

Application

The controller is used for capacity regulation of compressors and / or condensers in small refrigerating systems. This controller can regulate up to ten compressors. The condenser capacity is step regulated via the remaining available digital outputs and external relay module or variable speed regulated via a frequency converter.

Advantages

- Patented neutral zone regulation
- Sequential or cyclic operation
- Possibility of suction pressure optimisation via the data communication
- Load shedding function

Regulation

Regulation is based on signals from one pressure transmitter for the compressor regulation and one pressure transmitter for the condenser regulation plus one temperature sensor for the air temperature before the condenser.

Functions

- Relays for capacity regulation
- Voltage output for capacity regulation
- Status inputs. An interrupted signal indicates that the safety circuit has been activated and the respective circuit stopped
- Contact inputs for indication of alarms
- Contact inputs for displacement of references or for indication of alarms
- Alarm relay
- External start/stop of regulation
- Possibility of data communication

Operation

All operation takes place either via data communication or via connection of a display type EKA 164. The display can be disconnected after the installation.

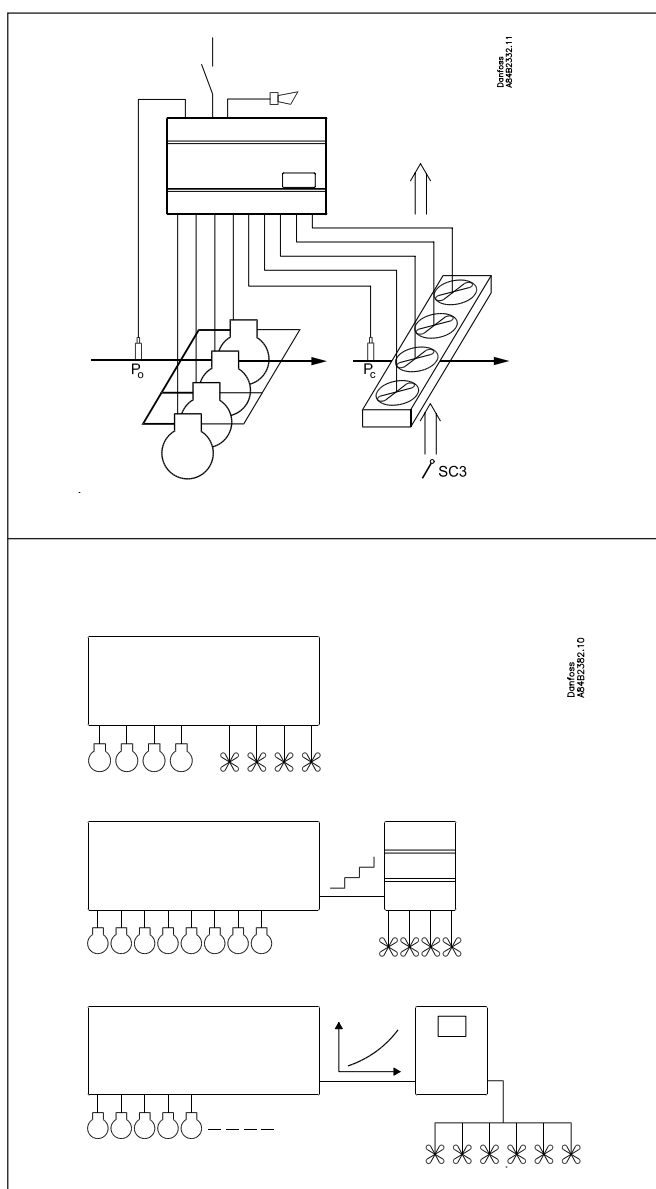

Function

Capacity regulation

The cut-in capacity is controlled by signals from the connected pressure transmitter and the set reference.

Outside the reference a neutral zone is set where the capacity will neither be cut in nor out.

Outside the neutral zone (in the hatched areas named +zone and -zone) the capacity will be cut in or out if the regulation registers a change of pressure "away" from the neutral zone.

Cut in and cut out will take place with the set time delays. If the pressure however "approaches" the neutral zone, the controller will make no changes of the cut-in capacity.

If regulation takes place outside the hatched area (named ++zone and --zone), changes of the cut-in capacity will occur somewhat faster than if it were in the hatched area.

Cut in of steps can be defined for either sequential or cyclic operation.

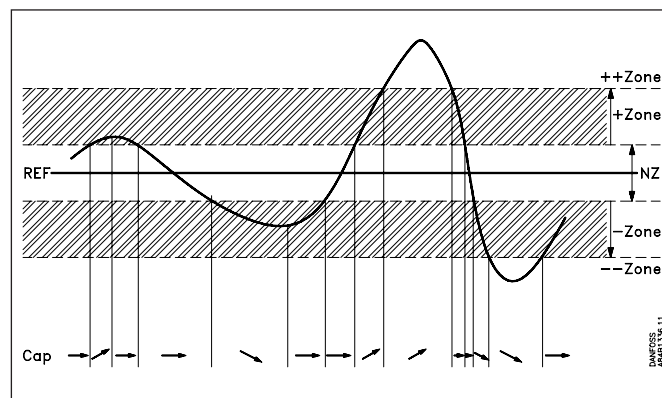

Sequential (first in - last out)

The relays are here cut in in sequence – first relay number 1, then 2, etc.

Cut out takes place in the opposite sequence, i.e. the last cut-in relay will be cut out first.

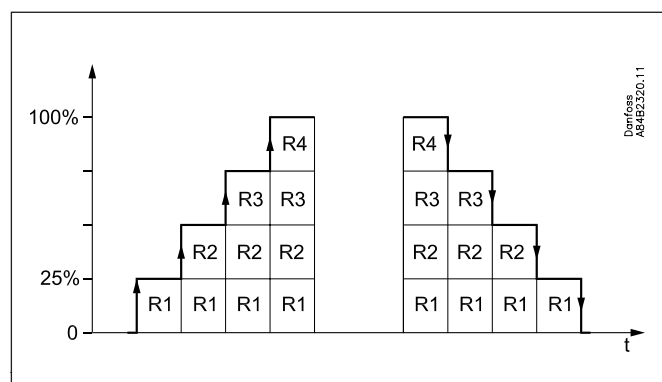

Cyclic (first in - first out)

The relays are coupled here so that the operating time of the individual relays will become equalised.

At each cutin the regulation scans the individual relays' timer, cutting in the relay with least time on it.

At each cutout a similar thing happens. Here the relay is cut out that has most hours on the timer.

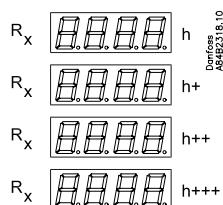

Rx = random relay
h = number of hours

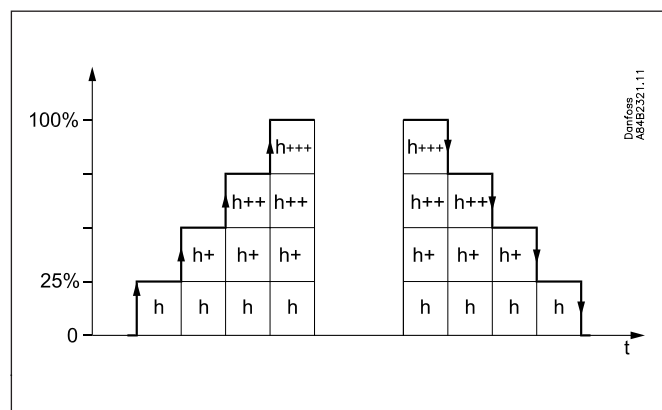

Suvey of functions

Function	Parameter	Parameter by operation via data communication
Normal display		
If the two displays are mounted: P0 will be shown on EKA 165 / EKA 164 (the one with buttons) Pc will be shown on EKA 163		P0 b (bar) Pc b (bar)
Compressor regulation reference		Compressor control
P0 setpoint Regulation is based on the set value plus an offset, if applicable. An offset can be created from night setback r13 and/or from a master gateway's override function.	r23	Set Point b
Offset The set reference may be displaced with a fixed value when a signal is received at the DI4 input or from the function "Night setback" (r27). (Cf. also Definition of DI4 input).	r13	Night offset
Night setback OFF: No change of the reference ON: Offset value forms part of the reference	r27	NightSetBack
Reference The regulation reference is shown here	r24	Comp ref. b
Set point limitation With these settings the setpoint can only be set between the two values. (This also apply if regulation with "P0-optimisation function")		
Max. permissible setpoint value.	r25	P0RefMax b
Min. permissible setpoint value.	r26	P0RefMin b
Neutral zone There is a neutral zone around the reference. See also page 3.	r01	Neutral zone
Correction of pressure measurement An offset adjustment of the registered pressure can be made.	r04	AdjustSensor
Unit Here you can select whether the display is to indicate pressure in bar or in Psig. And temperatures in °C or °F. 0: Will give bar and °C. 1: Will give Psig and °F.	r05	(In AKM only bar or °C is used, whatever the setting)
Start/stop of refrigeration With this setting the refrigeration can be started and stopped. Start/stop of refrigeration may also be performed with an external contact function connected to the input named "ON input".	r12	Main Switch
Condenser regulation reference		Condenser control
Pc setpoint Regulation is based on the set value plus an offset, if applicable. An offset can be created via the "r34" function and/or from a master gateway's override function.	r28	Set Point b
Offset The set reference may be displaced with a fixed value when a signal is received at the DI5 input. (Cf. also Definition of DI5 input).	r34	Press.offset
Pc reference variation 1: No change of the reference. Regulation based on set setpoint. 2: Outdoor temperature forms part of the reference. The outdoor temperature is measured with Sc3. When the outdoor temperature drops one degree, the reference is lowered one degree. Setting 1 and 2 operate with a PI regulation. If the system is unstable and the PI regulation not satisfactory the I element may be left out, so there will be P regulation only. 3: As 1, but with P regulation 4: As 2, but with P regulation	r33	Pc mode
The regulation reference is shown here.	r29	Cond ref. b
The mean temperature difference across the condenser at maximum load (dim tm K)	r35	Dim.Tm K
The mean temperature difference across the condenser at the lowest relevant compressor capacity (min tm K)	r56	Min tm K
Set point limitation With these settings the setpoint can only be set between the two values.		
Max. permissible setpoint value.	r30	PcRefMax b
Min. permissible setpoint value.	r31	PcRefMin b

Correction of pressure measurement An offset adjustment of the registered pressure can be made.	r32	AdjustSensor
Compressor capacity		Compressor pack config.
Running time To prevent frequent start/stop, values have to be set for how the relays are to cut in and out.		
Min. ON time for relays. (The time is not used if the relay cuts an unloader in or out).	c01	Min.ON time
Min. time period between cutin of same relay.	c07	MinRecyTime
Setting for neutral zone regulation		
Regulation band over the neutral zonen	c10	+ Zone b
Time delay between step cut-ins in the regulation band over the neutral zone	c11	+ Zone m
Time delay between step cut-ins in the regulation band over the "+Zone band".	c12	+ + Zone m
Regulation band under the neutral zone	c13	- Zone b
Time delay between step cut-outs in the regulation band under the neutral zone	c14	- Zone m
Time delay between step cut-outs in the regulation band under the "-Zone band"	c15	-- Zone m
Compressor configuration Here you set the combination of number of compressors and any unloaders. 1 = One compressor, 2 = two compressors, 3 = three, 4 = four....10 = ten. See page 9.	c16	Compr mode
Selection of coupling mode (See also the overview page 9) 1. Sequential: First relay 1 cuts in, then relay 2, etc. Cutout takes place in the opposite sequence. ("First in, last out"). 2. Cyclic: An automatic operating time equalisation is arranged here, so that all steps with motor connection will have the same operating time	c08	Step mode
Definition of condenser and number of fans Here you set the number of fan steps with which regulation has to be carried out (but max. eight). 1-8: All fans are cut in and out with relays. The first vacant relay number is assigned to fan 1, the next to number 2, etc. Steps after DO10 must be executed through connection of a relay module type EKC 331 to the analog output. Cf. drawing on page 9. 9: All fans are controlled via the analog output and a frequency converter. 10: Not used 11-18: Total number of fan relays which are to be connected with alternating start-up.	c29	No. of Fans
Read temperature at sensor Sc3	u44	Sc3 temp
Read temperature at sensor Sc4 (sensor is only used for monitoring)	u45	Sc4 temp
Read temperature at sensor "Saux"	u03	Saux temp
Status on DI3 input	u87	DI 3 status
Status on DI4 input	u88	DI 4 status
Status on DI5 input	u89	DI 5 status
	-	--- Comp. Cap % Read cut-in compressor capacity
	-	--- Cond. Cap % Read cut-in condenser capacity
Regulation parameters for the condenser regulation		
P: Amplification factor Xp (P = 100/Xp) If the Xp value is increased, the regulation becomes steadier	n04	Xp b
I: Integration time Tn If the Tn value is increased, the regulation becomes steadier	n05	Tn s
Cutin condenser capacity with manual control. See also "n53"	n52	FanManCap%
Manual control of condenser capacity (when ON, the value in "n52" will be used)	n53	FanManCap

Alarm		Alarm settings
The controller can give alarm in different situations. When there is an alarm all the light-emitting diodes (LED) will flash on the EKA 164, and the alarm relay will cut in. (The alarm relay may be used for a compressor No. 10, if required).		
P0 min. Here you set when the alarm at too low suction pressure is to enter into effect. The value is set as an absolute value.	A11	Min. P0. b
Alarm delay P0 min. The time delay is set in minutes. At setting = -1 the alarm is cancelled.	A44	Po.AlrmDelay
Pc max. Here you set when the alarm at too high condensing pressure is to enter into effect. The value is set as an absolute value.	A30	Max. Pc. b
Alarm delay Pc max. The time delay is set in minutes. At setting = -1 the alarm is cancelled.	A45	Pc.AlrmDelay
Alarm delay DI3 (an interrupted input will give alarm). The time delay is set in seconds. At max. setting the alarm is cancelled.	A29	DI3AlrmDelay
Alarm limit for high temperature of the "Saux." sensor With setting = 0 the alarm has been opted out.	A32	Saux
Alarm delay from "Saux" If the limit value is exceeded, a timer function will commence. The alarm will not become active until the set time delay has been passed. The time delay is set in minutes.	A03	Alarm delay
Give the top button a brief push to zeroset the alarm and to have the message shown on the display.		Reset alarm The function zerosets all alarms when set in pos. ON.
		With data communication the importance of the individual alarms can be defined. Setting is carried out in the "Alarm destinations" menu. See also page 8.
Miscellaneous		Miscellaneous
Pressure transmitter's working range Depending on the pressure, a pressure transmitter with a given working range is used. This working range must be set in the controller (e.g.: -1 to 12 bar). The values must be set in bar if display in °C has been selected. And in psig, if °F has been selected.		If the values are to be set from the AKM programme, they must be set in bar.
P0-Min. value	o20	P0MinTrsPres
P0-Max. value	o21	P0MaxTrsPres
Pc-Min. value	o47	PcMinTrsPres
Pc-Max. value	o48	PcMaxTrsPres
Function for relay output DO9: (Only if C16 < 9) 0. Start / stop of speed regulation 1. Inject on signal for evaporator control 2. Boost ready (at least one compressor is on) 3. Start /stop of condenser fan	o75	DO9 function
Function for relay output DO10: (Only if C16 < 10) 0. Alarm relay 1. Start / stop of speed regulation 2. Inject on signal for evaporator control 3. Boost ready (at least one compressor is on) 4. Start /stop of condenser fan	o76	DO10 function
Function for DI3: 0: Not used 1: Fan safety 2: Alarm input (A30 alarm)	o80	DI 3 control
Use of DI4 input The digital input can be connected to a contact function, and the contact can now be used for one of the following functions: Setting / function: 0: DI input not used 1: Regulation reference P0 displaced when contact is cut in 2: Alarm function when the contact cuts out. Alarm "A31" is given when the time delay has elapsed.	o22	DI4 control

<p>Use of DI5 input The digital input can be connected to a contact function, and the contact can now be used for one of the following functions: Setting / function: 0: DI input not used 1: Regulation reference Pc displaced when contact is cut in 2: Alarm function when the contact cuts out. Alarm "A32" is given when the time delay has elapsed.</p>	o37	Di5 control
<p>Operating hours The operating hours for the compressor relays can be read in the following menus. The read value is multiplied by 1000 to obtain the number of hours (f.ex. shows 2.1 for 2100 hours). On reaching 99.9 hours the counter stops and must now be reset to, say, 0. There will be no alarm or error message for counter overflow.</p>		(In the AKM display the hour number has not been multiplied)
Value for relay number 1	o23	DO1 run hour
Value for relay number 2	o24	DO2 run hour
Value for relay number 3	o25	DO3 run hour
Value for relay number 4	o26	DO4 run hour
Value for relay number 5	o50	DO5 run hour
Value for relay number 6	o51	DO6 run hour
Value for relay number 7	o52	DO7 run hour
Value for relay number 8	o53	DO8 run hour
Value for relay number 9	o53	DO9 run hour
Value for relay number 10	o55	DO10 run hour
<p>Refrigerant setting Before refrigeration is started, the refrigeration must be defined. You may choose between the following refrigerants: 1 = R12. 2 = R22. 3 = R134a. 4 = R502. 5 = R717. 6 = R13. 7 = R13b1. 8 = R23. 9 = R500. 10 = R503. 11 = R114. 12 = R142b. 13 = User defined. 14 = R32. 15 = R227. 16 = R401A. 17 = R507. 18 = R402A. 19 = R404A. 20 = R407C. 21 = R407A. 22 = R407B. 23 = R410A. 24 = R170. 25 = R290. 26 = R600. 27 = R600a. 28 = R744. 29 = R1270. 30 = R417A. 31 = R422A. 32 = R413A. 33 = R422D. 34 = R427A. 35 = R438A. 36 = R513A. 37 = R407F. Warning: Wrong selection of refrigerant may cause damage to the compressor.</p>	o30	Refrigerant
<p>Manual control (stopped regulation only) From this menu the relays can be cut in and out manually. 0 gives no override, but a number between 1 and 10 will cut in a belonging relay. 1 will cut in relay number 1, 2 relay 2, etc. 11-18 will produce voltage on the analog output. In this way the relays on the external relay module can be activated. Setting 11 will give a voltage of 1.25 V, setting 12 will give 2.5 V, etc.</p>	o18	---
<p>Frequency Set the net frequency.</p>	o12	50 / 60 Hz (50 = 0, 60 = 1)
<p>Display connection Off: EKA 164 On: EKA 165 (extended display with light-emitting diodes)</p>	o82	---
<p>Address If the controller is built into a network with data communication, it must have an address, and the master gateway of the data communication must then know this address. These settings can only be made when a data communication module has been mounted in the controller and the installation of the data communication cable has been completed. This installation is mentioned in a separate document "RC.8A.C".</p>		Following installation of a data communication module, the controller can be operated on a par with the other controllers in ADAP-KOOL® refrigeration controls.
The address is set between 1 and 60	o03	
The address is sent to the gateway when the menu is set in pos. 0	o04	
<p>Access code If the settings in the controller are to be protected by a numerical code, you can set a numerical value between 0 and 100. If not, you can cancel the function with setting OFF.</p>	o05	

Operating status		
The controller goes through some regulating situations where it is just waiting for the next point of the regulation. To make these "why is nothing happening" situations visible, you can see an operating status on the display. Push briefly (1s) the upper button. If there is a status code, it will be shown on the display. The individual status codes have the following meanings		EKC state (0 = regulation)
S2: When the relay is operated, it must be activated for min. x minutes (cf. c01)		2
S5: Renewed cutin of the same relay must not take place more often than every x minutes (cf. c07)		5
S8: The next relay must not cut in until x minutes have elapsed (cf.c11-c12)		8
S9: The next relay must not cut out until x minutes have elapsed (cf. c14-c15)		9
S10: Regulation stopped with the internal og external start/stop		10
S25: Manuel control of outputs via function "o18"		25
S34: Safety cutout. Setting A30 is exceeded or all safety inputs (29-36) are open		34
S47: Controller is in "Load shed mode"		47
PS: Access code is required before you have access to the settings		
Alarm messages		Alarms "Destinations"
A2: Low P0		--- Low P0 alarm
A11: No refrigerant has been selected (cf. o30)		--- No RFG Sel
A17: High Pc		--- Hi Pc alarm
A19 - 26: Compressor fault. Interrupted signal on input "Comp 1" /2/3/4/5/6/7/8		--- Comp_ fault
A27: High temperature alarm for sensor "Housing"		--- Housing temp
A28: External alarm. Interrupted signal on input "DI1"		Comp 9 fault
A29: External alarm. Interrupted signal on input "DI2"		Comp 10 fault
A30: External alarm. Interrupted signal on input "DI3"		DI3 alarm
A31: External alarm. Interrupted signal on input "DI4"		DI4 alarm
A32: External alarm. Interrupted signal on input "DI5"		DI5 alarm
A34: Fan failure. Interrupted signal on input "Fan 1" ("DI3")		--- Fan _ fault
A45: Regulation stopped with setting or with external switch		A45 Stand by
E1: Error in the controller		Ctrl. fault
E2: Control signal outside the range (short-circuited/interrupted)		Out of range

Configuration settings (compressor and fan definitions, coupling mode and refrigerant) can only take place when regulation is stopped.

Compressor configuration

Setting "c16" will define the configuration.
Setting "c08" will define coupling mode.

Relay no.										C 16	C 08
1	2	3	4	5	6	7	8	9	10	=	=
1										1	1
1	2									2	1 / 2
1	2	3								3	1 / 2
1	2	3	4							4	1 / 2
1	2	3	4	5						5	1 / 2
1	2	3	4	5	6					6	1 / 2
1	2	3	4	5	6	7				7	1 / 2
1	2	3	4	5	6	7	8			8	1 / 2
1	2	3	4	5	6	7	8	9		9	1 / 2
1	2	3	4	5	6	7	8	9	10	10	1 / 2

Danfoss
04B102/10

Capacity step

All capacity steps are presumed to be identical.

Coupling mode

Coupling mode 1 = *sequential* operation.
Coupling mode 2 = *cyclic* operation.

Condenser couplings

When the compressor relays have been established the turn comes to the fan relays.

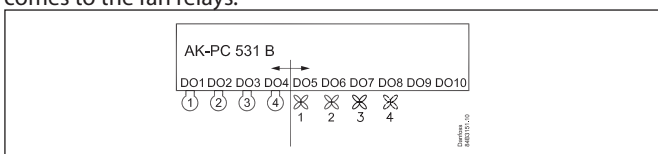

The first vacant relay (DO1-DO10) will become the first fan relay. It will be followed by the subsequent relays. If more relays are required than the vacant DO relays, a relay module can be connected to the analog output. The function is, as follows:

If there are up to four external fans on an EKC 331:

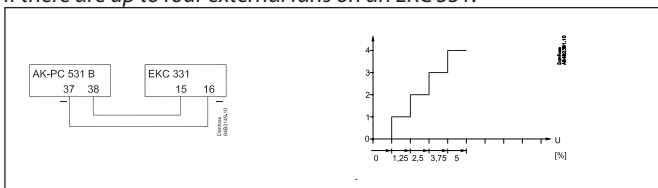

In EKC 331 the voltage range must be set to 0-5 V ("o10" = 6).
In EKC 331 the number of steps must be set to 4 ("o19" = 4) (also when fewer fans are connected).

If there are more than four external fans on two EKC 331 units:

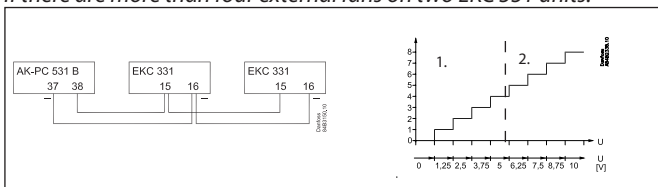

In the first EKC 331, set 0-5 V ("o10" = 6).
In the second EKC 331, set 5-10 V ("o10" = 7).
In both EKC's the number of steps must be set to 4 ("o19" = 4) (also when fewer fans are connected to the second EKC).

Alternating start-up of fans:

(only if c29 is 11 to 18)

The fans can be defined to start alternately when they have all been stopped.

The first time regulation is started, fan 1 will be started first – the regulation determines whether additional fans will be started. After the next time all fans are stopped, fan 2 will be the first to be started, and so on.

Fan 1 will again be the first fan to be started when the rotation has been through the total number of fans.

If there is more than one fan on an EKC 331, it will not be possible to start the other fans first. Here, the fan with the lowest voltage step will always be the one which is started first.

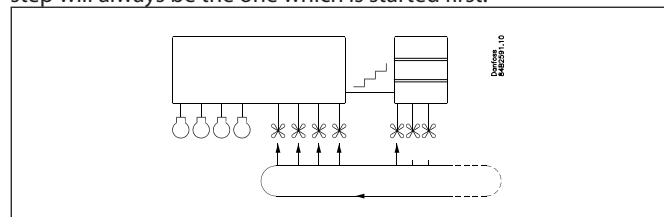

If the entire condenser capacity is to be controlled by a frequency converter:

AK-PC 531B must send an analog signal about the required capacity ("c29" = 9).

The signal varies from 0 to 10 V. Signal and capacity have the following context.

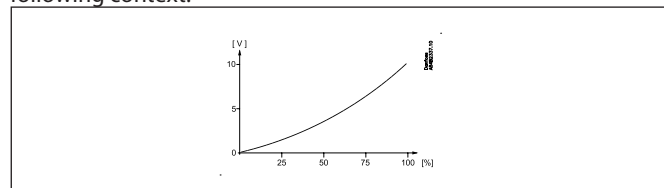

Operation

Data communication

If the controller is extended with data communication, the operation can be performed from a system unit.

The importance of the alarms that are sent can be defined with the setting: 1 (High), 2 (Medium), 3 (Low) or 0 (No alarm).

Operation via external display

The values will be shown with three digits, and with a setting you can determine whether the pressures are to be shown in SI units (°C / bar) or US units (°F / psig.).

There are three options for the display.

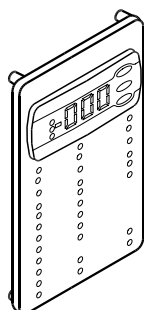

EKA 165

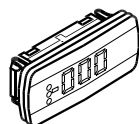

EKA 163

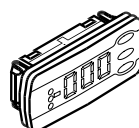

EKA 164

EKA 165

To operate the controller and view the evaporation pressure. If the lowermost key is pressed, the condensation pressure will be shown briefly in the display. (If regulation is based only on the condensation pressure, the display will always show P_c).

During normal operation the light-emitting diodes in the display will indicate where regulation is taking place.

Highest + second highest	:	++Zone
Second highest	:	+Zone
"None"	:	Neutral zone
Second lowest	:	-Zone
Lowest+ second lowest	:	-- Zone

The other LEDs on the display will show the functions that are active:

- Relays for compressors
- Relays for fans
- Input signals for the digital inputs
- The optimisation LED will light up when the reference is 2 K or more over the set point.

EKA 163

If the condensation pressure is to be shown constantly, a display without operating keys can be connected.

EKA 164

To operate the controller and view the evaporation pressure. If the lowermost key is pressed, the condensation pressure will be shown briefly in the display.

Like the EKA 165, the LEDs in the display will show where the regulation is located.

The buttons on the display

When you want to change a setting, the upper and the lower buttons will give you a higher or lower value depending on the button you are pushing. But before you change the value, you must have access to the menu. You obtain this by pushing the upper button for a couple of seconds - you will then enter the column with parameter codes. Find the parameter code you want to change and push the middle button. When you have changed the value, save the new value by once more pushing the middle button.

Or short:

1. Push the upper button (long push) until a parameter is shown
2. Push one of the buttons and find the parameter you want to change
3. Push the middle button until the setting value is shown
4. Push one of the buttons and select the new value
5. Push the middle button again to conclude the setting

(A brief pushing will show the active alarm codes.)

Menu survey

Sequence

1. Quick- start

To get the system up and running quickly so that cooling can be commenced, start it by setting the following parameters (these parameters can only be set when the regulation is stopped r12=0):

r23, r28 and then either (c08 and c16) – continue with c29, o30, o75, o76, o80 and finally r12=1.

2. Once the regulation is under way, you can go through the other parameters and adjust them in situ.

SW: 1.0x

Function	Parameter	Min.	Max.	Factory setting
Normal display				
Shows P0 in EKA 165 (display with buttons)	-	bar		
Shows Pc in EKA 163	-	bar		
P0 reference				
Neutral zone	r01	0.1 bar	5.0 bar	0.4 bar
Correction of signal from P0 sensor	r04	-5.0 bar	5.0 bar	0.0 bar
Select view; SI or US. 0=SI (bar /°C), 1=US (Psig /°F)	r05	0	1	0
Start/Stop of regulation	r12	OFF	ON	OFF
Reference offset for P0 (see also r27)	r13	-5.0 bar	5.0 bar	0.0 bar
Set regulation setpoint for P0	r23	-1 bar	60.0 bar	3.5 bar
Shows total P0 reference (r23 + various displacements)	r24		bar	
Limitation: P0 reference max. value (also applies to regulation with reference displacement)	r25	-1.0 bar	60.0 bar	40.0 bar
Limitation: P0 referencen min. value (also applies to regulation with reference displacement)	r26	-1.0 bar	40.0 bar	-1.0 bar
Displacement of P0 (ON=active "r13")	r27	OFF	ON	OFF
Pc reference				
Set regulation setpoint for Pc	r28	0.0 bar	110.0 bar	15.0 bar
Shows total Pc reference	r29		bar	
Limitation: Pc referencen max. value	r30	-0.0 bar	130.0 bar	60.0 bar
Limitation: Pc referencen min. value	r31	0.0 bar	60.0 bar	0.0 bar
Correction of signal from Pc sensor	r32	-5.0 bar	5.0 bar	0.0 bar
Pc reference variation. 1 and 2 are PI-regulation 1: Fixed reference. "r28" is used 2: Variable reference. Outdoor temperature (Sc3) included in the reference 3: As 1, but with P-regulation (Xp-band) 4: As 2, but with P-regulation (Xp-band)	r33	1	4	1
Reference offset for Pc	r34	-5.0 bar	5.0 bar	0.0 bar
The mean temperature difference across the condenser at maximum load (dim tm K)	r35	3.0	50.0	10.0
The mean temperature difference across the condenser at the lowest relevant compressor capacity (min tm K)	r56	3.0	50.0	8.0
Capacity				
Min. ON time for compressor relays	c01	0 min	30 min.	0
Min. time period between cutins of same compressor relay	c07	0 min.	60 min	4
Definition of regulation mode 1: Sequential (step mode / FILO) 2: Cyclic (step mode / FIFO)	c08	1	2	1
Regulation parameter for + Zone	c10	0.1 bar	2.0 bar	0.4 bar
Regulation parameter for + Zone	c11	0.1 min	60 min	4.0
Regulation parameter for ++ Zone	c12	0.1 min.	20 min	2.0
Regulation parameter for - Zone	c13	0.1 bar	2.0 bar	0.3 bar
Regulation parameter for - Zone	c14	0.1 min.	60 min	1.0
Regulation parameter for -- Zone	c15	0.02 min.	20 min	0.5
Definition of compressor connections. See options on page 3.	c16	1	10	0
Definition of condenser: 1-8: Total number of fan relays or voltage step on the voltage output 9: Only via analog output and start of frequency converter 10: Not used 11- 18: Total number of fan relays which are to be connected with alternating start-up.	c29	0/OFF	18	0

To be continued

Cut in compressor capacity with manual control. See also "c32"	c31	0%	100%	0
Manual control of compressor capacity (when ON, the value in "c31" will be used)	c32	OFF	ON	OFF
Set capacity for Load shed period	c35	0%	100%	25%
Po limit to stop Load shed	c36	0.0 bar	60.0 bar	60.0 bar
Max period for Load shed On	c37	5 min.	60 min.	30 min.
Control Load shed on/off	c91	0/OFF	1/ON	0/OFF
Proportional band Xp for (P= 100/Xp) condenser regulation	n04	0.2 bar	10.0 bar	3.0 bar
I: Integration time Tn for condenser regulation	n05	30 s	600 s	150
Cutin condenser capacity with manual control. See also "n53"	n52	0%	100%	0
Manual control of condenser capacity (when ON, the value in "n52" will be used)	n53	OFF	ON	OFF
Start speed The voltage for the speed regulation is kept at 0V until the regulation requires a higher value than the value set here.	n54	0%	75%	20%
Min. speed. The voltage for the speed regulation switches to 0V when the regulation requires a lower value than the value set here.	n55	0%	50%	10%
Alarm				
Delay time for a A32 alarm	A03	0 min.	90 min.	0 min.
Low alarm and safety limit for P0	A11	-1.0 bar	40 bar	0.5 bar
Delay time for a DI3 alarm	A29	0 min. (-1=OFF)	999 min.	OFF
Upper alarm and safety limit for Pc	A30	0.0 bar	200 bar	60.0 bar
Upper alarm limit for sensor "Saux1"	A32	1°C (0=OFF)	140°C	OFF
Delay time for a P0 alarm	A44	0 min. (-1=OFF)	999 min.	0 min.
Delay time for a Pc alarm	A45	0 min. (-1=OFF)	999 min.	0 min.
Miscellaneous				
Controllers address	o03*	1	990	
On/off switch (service-pin message)	o04*	-	-	
Access code	o05	1 (0=OFF)	100	OFF
Set supply voltage frequency	o12	50 Hz	60 H	0
Manual control of outputs: 0: No override 1-10: 1 will cut in relay 1, 2 relay 2, etc. 11-18: Gives voltage signal on the analog output. (11 gives 1.25 V, and so on in steps of 1.25 V	o18	0	18	0
P0 pressure transmitter's working range - min. value	o20	-1 bar	0 bar	-1.0
P0 pressure transmitter's working range - max. value	o21	1 bar	200 bar	12.0
Use of DI4-input 0 =not used. 1 =P0 displacement. 2 =alarm function. Alarm="A31"	o22	0	2	0
Operating hours of relay 1 (value time 1000)	o23	0.0 h	99.9 h	0.0
Operating hours of relay 2 (value time 1000)	o24	0.0 h	99.9 h	0.0
Operating hours of relay 3 (value time 1000)	o25	0.0 h	99.9 h	0.0
Operating hours of relay 4 (value time 1000)	o26	0.0 h	99.9 h	0.0
Setting of refrigerant 1=R12. 2=R22. 3=R134a. 4=R502. 5=R717. 6=R13. 7=R13b1. 8=R23. 9=R500. 10=R503. 11=R114. 12=R142b. 13=User defined. 14=R32. 15=R227. 16=R401A. 17=R507. 18=R402A. 19=R404A. 20=R407C. 21=R407A. 22=R407B. 23=R410A. 24=R170. 25=R290. 26=R600. 27=R600a. 28=R744. 29=R1270. 30=R417A. 31=R422A. 32=R413A. 33=R422D. 34=R427A. 35=R438A. 36=R513A. 37=R407F	o30	0	37	0
Use of DI5-input 0 =not used. 1 =Pc displacment. 2 =alarm function. Alarm="A32"	o37	0	2	0
Pc pressure transmitter's working range - min. value	o47	-1 bar	0 bar	-1.0
Pc pressure transmitter's working range - max. value	o48	1 bar	200 bar	34.0
Operating hours of relay 5 (value time 1000)	o50	0.0 h	99.9 h	0.0
Operating hours of relay 6 (value time 1000)	o51	0.0 h	99.9 h	0.0
Operating hours of relay 7 (value time 1000)	o52	0.0 h	99.9 h	0.0
Operating hours of relay 8 (value time 1000)	o53	0.0 h	99.9 h	0.0
Operating hours of relay 9 (value time 1000)	o54	0.0 h	99.9 h	0.0
Operating hours of relay 10 (value time 1000)	o55	0.0 h	99.9 h	0.0
Function for relay output DO9: (Only if C16 < 9) 0. Start / stop of speed regulation 1. Inject on signal for evaporator control 2. Boost ready (at least one compressor is on) 3. Start /stop of condenser fan	o75	0	3	0

* this setting is only possible if data communication module is mounted in the controller

To be continued

Function for relay output DO10: (Only if C16 < 10) 0. Alarm relay 1. Start / stop of speed regulation 2. Inject on signal for evaporator control 3. Boost ready (at least one compressor is on) 4. Start /stop of condenser fan	o76	0	4	0
Function for DI3: 0: Not used 1: Fan safety 2: Alarm input (A30 alarm)	o80	0	2	0
Display connection Off: EKA 164 On: EKA 165 (extended display with light-emitting diodes)	o82	Off	On	Off
Service				
Read temperature at sensor "Saux"	u03			°C
Read temperature at sensor "Sc3"	u44			°C
Read temperature at sensor "Sc4"	u45			°C
Status on DI3 input	u87			
Status on DI4 input	u88			
Status on DI5 input	u89			

The controller can give the following messages

E1	Error message	Fault in controller	
E2		Regulation is outside the range, or the control signal is defective *	
A2	Alarm message	Low P0	
A11		Refrigerant not selected	
A17		High Pc	
A19		Compressor 1 error	The actual compressors safety circuit is interrupted. That is to say the signal is missing on one of the terminals 29-36
A20		Compressor 2 error	
A21		Compressor 3 error	
A22		Compressor 4 error	
A23		Compressor 5 error	
A24		Compressor 6 error	
A25		Compressor 7 error	
A26		Compressor 8 error	
A27		Room temperature alarm (Saux1 temp.)	
A28		DI 1 alarm. Compressor 9 error	
A29		DI 2 alarm. Compressor 10 error	
A30		DI 3 alarm. Terminal 49 interrupted	
A31	DI 4 alarm. Terminal 50 interrupted		
A32	DI 5 alarm. Terminal 52 interrupted		
A34	Fan alarm. There is no signal on DI1 input		
A45	Regulation stopped		

S0	Status message	Regulation
S2		Wait for "c01"
S5		Wait for "c07"
S8		Wait for "c11" or "c12"
S9		Wait for "c14" or "c15"
S10		Refrigeration stopped by the internal or external start/stop function
S25		Manual control of outputs
S34		Safety cutout. Setting A30 is exceeded or all safety inputs (29-36) are open
S47	Controller is in "Load shed mode"	
PS	Info	Access code is required before you have access to the settings

Messages can be brought up on the display by briefly pressing the uppermost key. If there is more than one alarm, they can be scrolled through

Factory setting

If you need to return to the factory-set values, it can be done in this way:

- Cut out the supply voltage to the controller
- Keep upper and lower button depressed at the same time as you reconnect the supply voltage

Override

The controller contains a number of functions that can be used together with the override function in the master gateway. They can therefore only be used in combination with data communication.

Function via data communication	Functions to be used in the gateway's override function	Selection of parameter in AK-PC 531B 084B8014 Sw.1.0x
Stop of injection when the compressor is stopped	AKC ON	--- MC Inject ON
Night setback	Day/night control and time schedule	r27 NightSetback
Suction pressure optimisation	P0 optimisation	Select controller address (The parameters are found automatically and do not become visible).
AK-PC 531B registers the refrigeration point which handles the largest capacity (requires the lowest suction pressure). The parameter may be logged for use in a service situation.		--- MLC

Safety function

Monitoring of maximum discharge pressure

The function cuts in all condenser steps and gradually cuts out compressor steps, if the condensing pressure exceeds the permitted value. The cutout limit is the setting in "A30".

The function starts at a value that is 3 K below the set value. At this point the entire condenser capacity is cut in at the same time as 33% of the compressor capacity is cut out. (however min. one step). This is repeated for each 30-second interval. The alarm function is activated.

If the temperature (pressure) rises to the set limit value, the following happens:

- all compressor steps are immediately cut out
- the condenser capacity remains cut in

The alarm ceases when the temperature (pressure) has dropped to the 3 K below the limit value for 60 seconds.

Renewed cut in of compressor steps is allowed when the temperature (pressure) has dropped to the 3 K below the limit value. Restart of the compressor is dependent on expiry of the restart timer.

Monitoring of minimum suction pressure

The function immediately cuts out all compressor steps if the suction pressure becomes lower than the permitted value. The cut out limit is the setting in "A11".

Cut outs activate the alarm function.

The alarm ceases when the pressure (temperature) is above the cut out limit.

Renewed cut in of compressor steps is allowed when the alarm has stopped (the time delay has expired).

Emergency procedure

If the controller registers irregularities in the registered signals, it will start an emergency procedure:

For compressor regulation:

- If the signal from the pressure transmitter becomes smaller than expected, the controller will continue operating with the average capacity that has been cut in during the past 60 minutes. This cut-in capacity will gradually decline as time passes.
- If the signal for the suction pressure becomes smaller than the set value of A11, the capacity will instantly be cut out.

For condenser regulation:

- If the signal from the pressure transmitter becomes smaller than expected, or if the condensing pressure becomes bigger than the set value of A30, the entire capacity will instantly be cut in.

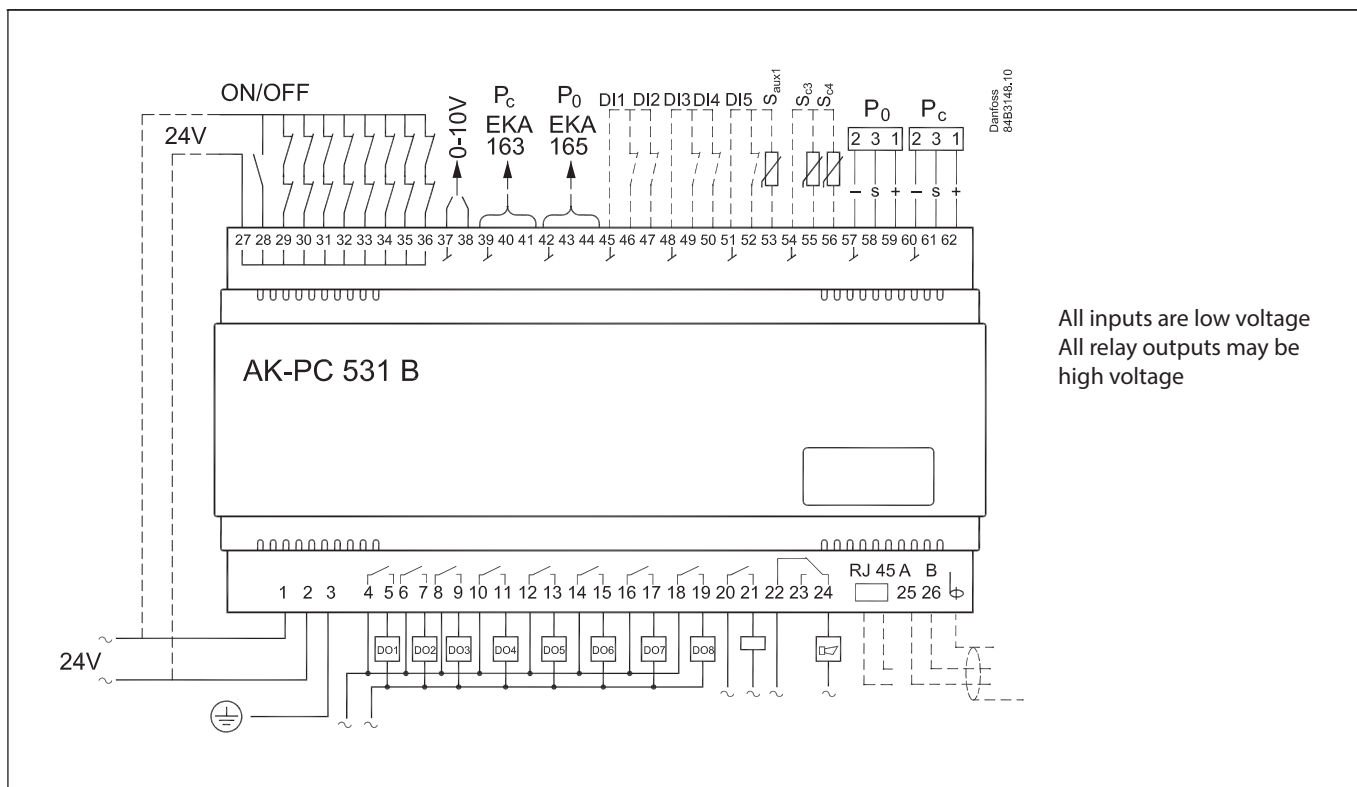

Connections

Necessary connections

Terminals:

- 1-2 Supply voltage 24 V a.c.
- 4- 19 Relay outputs for either compressors, unloaders or fan motors

- 27-28 24 V signal to start / stop of regulation
- 27-29 24 V signal from the safety circuit DO 1
- 27-30 24 V signal from the safety circuit DO 2
- 27-31 24 V signal from the safety circuit DO 3
- 27-32 24 V signal from the safety circuit DO 4
- 27-33 24 V signal from the safety circuit DO 5
- 27-34 24 V signal from the safety circuit DO 6
- 27-35 24 V signal from the safety circuit DO 7
- 27-36 24 V signal from the safety circuit DO 8
- 57-59 Suction pressure. Voltage signal from AKS 32R **
- 60-62 Condenser pressure. Voltage signal from AKS 32R **

Application dependent connections

- 20-21 Compressor 9, if applicable
Or any safety function.
- 22-23 Compressor 10, if applicable
Or alarm relay on 22-24, if there is one
There is connection between 22 and 24 in alarm situations and when the controller is de-energised
- 37-38 Voltage signal to external condenser control (see settings page 4)
- 39-41 Possibility of connecting an external display type EKA 163 for display of Pc
- 42-44 Possibility of connecting an external display type EKA 163 for display of P0, or EKA 165 for operation and display of P0
- 45-46 DI1 - Compressor 9 safety circuit (On = OK)
- 45-47 DI2 - Compressor 10 safety circuit (On = OK)
- 48-49 DI3 - Contact function for alarm signal
- 48-50 DI4 - Contact function for displacement of the suction pressure reference or for alarm signal.
- 51-52 DI5 - Contact function for displacement of the condenser pressure reference or for alarm signal.
- 51-53 Separate sensor Saux1. Sensor signal from AKS 11/ AKS 12
- 54-55 Out temperature Sc3. Sensor signal from AKS 11/ AKS 12
- 54-56 Separate sensor Sc4. Sensor signal from AKS 11/ AKS 12

Data communication

- 25-26 Mount only, if a data communication module has been fitted.
For ethernet communication the plug connection RJ45 must be used.
It is important that the installation of the data communication cable be done correctly. Cf. separate literature No. RC8AC.

Data

Supply voltage	24 V a.c. +/-15% 50/60 Hz, 5 VA	
Input signal	2 pcs. Pressure transmitters type AKS 32R	
	3 pcs. temperature sensor input for PT 1000 ohm/0°C or PTC 1000 ohm/25°C	
Digitale input from contact function.	1 pcs. for Start/stop of regulation	
	8 pcs. for monitoring of safety circuits	
	3 pcs. for alarm function	
	2 pcs. for alarm function or for displacement of references	
Relay output for capacity regulation	8 pcs. SPST	AC-1: 3 A (ohmic) AC-15: 2 A (inductive)
Relay output for capacity regulation or other function	1 pcs. SPST	
Alarm relay or Relay output for capacity regulation or other function	1 pcs. SPDT	AC-1: 6 A (ohmic) AC-15: 3 A (inductive)
Voltage output	0-10 V d.c.	
Display outputs	EKA 163	Pc display
	EKA 164 or EKA 165	Operation and P0 display
Data communication	Possible to connect a data communication module	
Environments	0 - 55°C, during operation	
	-40 - 70°C, during transport	
	20 - 80% Rh, not condensing	
	No shock influence / vibrations	
Enclosure	IP 20	
Weight	0.4 kg	
Mounting	DIN rail or on wall	
Terminals	max. 2.5 mm ² multicore	
Approvals	EU Low voltage Directive and EMC demands re CE-marking complied with. LVD-tested acc. to EN 60730-1 and EN 60730-2-9 EMC-tested acc. to EN61000-6-2 and 3	

Pressure transmitter / temperature sensor

Please refer to catalogue RK.OY.G...

Installation considerations

Accidental damage, poor installation, or site conditions, can give rise to malfunctions of the control system, and ultimately lead to a plant breakdown.

Every possible safeguard is incorporated into our products to prevent this. However, a wrong installation, for example, could still present problems. Electronic controls are no substitute for normal, good engineering practice.

Danfoss will not be responsible for any goods, or plant components, damaged as a result of the above defects. It is the installer's responsibility to check the installation thoroughly, and to fit the necessary safety devices.

Special reference is made to the necessity of signals to the controller when the compressor is stopped and to the need of liquid receivers before the compressors.

Your local Danfoss agent will be pleased to assist with further advice, etc.

Ordering

Type	Function	Code no.
AK-PC 531B	Capacity controller	084B8014
EKA 163B	Display unit	084B8574
EKA 164B	Display unit with operation buttons	084B8575
EKA 165	Display unit with operation buttons and LEDs	084B8573
	Cable for display unit 2 m, 1 pcs.	084B7298
	Cable for display unit 6 m, 1 pcs.	084B7299
EKA 175	Data communication module, RS 485	084B7093
EKA 177	Data communication module, Ethernet	084B8031

Dimensions

