

Data sheet

Thermo. operated water valve Type WVTS



Thermo. operated water valve type WVTS is suitable for controlling the temperature of a flow of water or neutral brine.

WVTS opens on rising sensor temperature and is indirect servo operated thermostatic valve.

It is suitable for controlling temperature in industrial applications by regulating the quantity of cooling water or neutral brine that cools down the process.

The valves are self-acting, i.e. they operate without the supply of auxiliary energy such as electricity or compressed air.

The required temperature is maintained constant without unnecessary use of cooling water in cooling systems.

The operating economy and efficiency are maximized.

Features

- Insensitive to dirt
- Insensitive to water pulsating pressure
- Proven reliable through decades
- Easy to service
- Built-in pilot filter
- Long lifetime
- High performance
- Very high capacity
- Both welding and thread connection flanges

Technical data

Type	WVTS for neutral media
Operation	Servo-operated

Sensor side

Temperature range	0 – 30 °C	25 – 65 °C	50 – 90 °C
Max. sensor temperature	57 °C	90 °C	125 °C

Liquid side

Media	Fresh water, neutral brine
Media temperature range	- 25 – 90 °C
Permissible working pressure PB	10 bar
Max. test pressure	16 bar
Opening differential pressure	WVTS 32 – WVTS 40: min. 0.5 bar; max. 4 bar
	WVTS 50 – WVTS 100: min. 0.3 bar; max. 4 bar

Valves are supplied with capillary tube gland.
Different lengths of capillary tube are available.

If WVTS is required with an opening differential pressure of 1 – 10 bar, the valve servo spring must be replaced. See "Ordering".

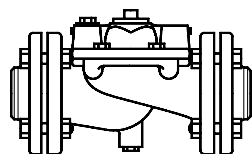
Ordering

WVTS components

Valve type	Connection	K _v value ²⁾ [m ³ /h]	Code no.		
			Valve housing	Flange set ³⁾	Special servo spring for differential pressure range 1 – 10 bar
WVTS 32	G 1¼ ¹⁾	12.5	016D5032	—	016D1327
WVTS 40	G 1½ ¹⁾	21.0	016D5040	—	016D0575
WVTS 50	2 in. weld fl.	32.0	016D5050 ⁴⁾	027N3050	016D0576
WVTS 65	2½ in. weld fl.	45.0	016D5065 ⁴⁾	027N3065	016D0577
WVTS 80	3 in. weld fl.	80.0	016D5080 ⁴⁾	027N3080	016D0578
WVTS 100	4 in. weld fl.	125.0	016D5100 ⁴⁾	027N3100	016D0579

¹⁾ ISO 228-1.

²⁾ The k_v value is the flow quantity of water in [m³/h] with a pressure drop across the valve of 1 bar, p = 1000 kg/m³.

³⁾ Code nos. include 2 flanges.

⁴⁾ Code nos. include valve housing, flange gaskets, flange bolts and screws for pilot valve.

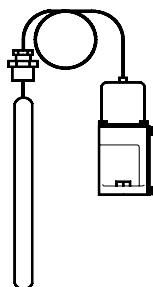
WVTS, thermostatic pilot element ¹⁾

Range [°C]	Capillary tube length [m]	Code no.
0 – 30	2	016D1002
25 – 65	2	016D1003
50 – 90	2	016D1004
0 – 30	5	016D1005
25 – 65	5	016D1006
50 – 90	5	016D1007

¹⁾ The pilot element includes control element and spring housing.

Accessories

Description	Code no.
Immersion sensor (sensor pocket)	003N0050
Capillary tube gland ¹⁾	003N0155

¹⁾ 1 capillary tube gland supplied as standard accessory

Material - parts in contact with the medium

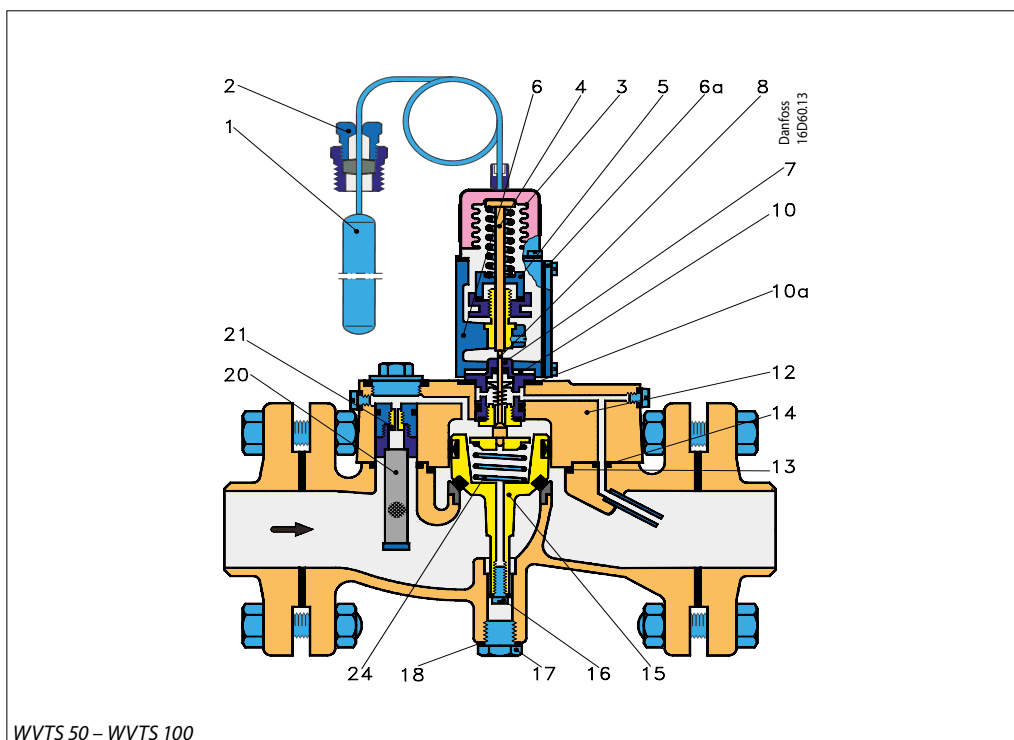
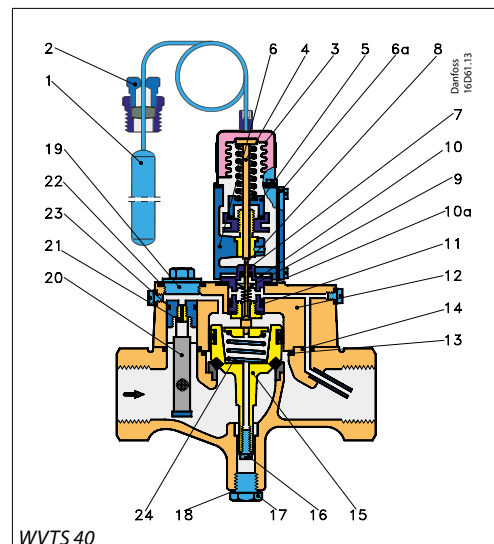
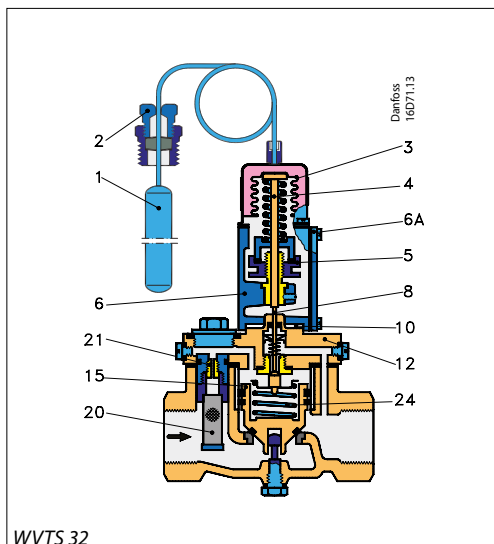

- 1. Sensor
- 2. Gland
- 3. Bellows element
- 4. Pressure rod
- 5. Regulating nut
- 6. Setting element housing
- 6a. Cover
- 7. Pilot orifice assembly
- 8. Pilot cone
- 10. Insulating washer
- 12. Valve cover
- 15. Servo piston
- 20. Filter cartridge (self-cleaning)
- 21. Equalising orifice
- 24. Servo spring

The valve body is made of cast iron with pressed-in bronze seat.
 The pilot orifice assembly (7) consists of a housing with seat and pilot cone of stainless steel.
 A filter cartridge (20) is built into the valve cover. Here the equalising orifice is protected by a replaceable filter.
 The bellows in the bellows element (3) are of tin bronze. In designing WVTS, great emphasis was placed on producing a valve with a completely tight seat and no external leakage. The servo piston was therefore fitted with a ring of special rubber that creates an elastic seal against the valve seat.

A specially designed rubber sleeve ensures that the servo piston moves in the cylinder with minimum friction.
 External valve leakage is prevented at the pilot cone where the spindle is fitted with Teflon cupwashers.
 Cover gaskets and pilot channel seals are rubber.
 The water-tight rubber seal between cover (6a) and housing (6) ensure that moisture cannot enter and freeze up the spindle.
 The insulating washer (10) prevents heat transmission between valve body and setting element housing.

Capacity

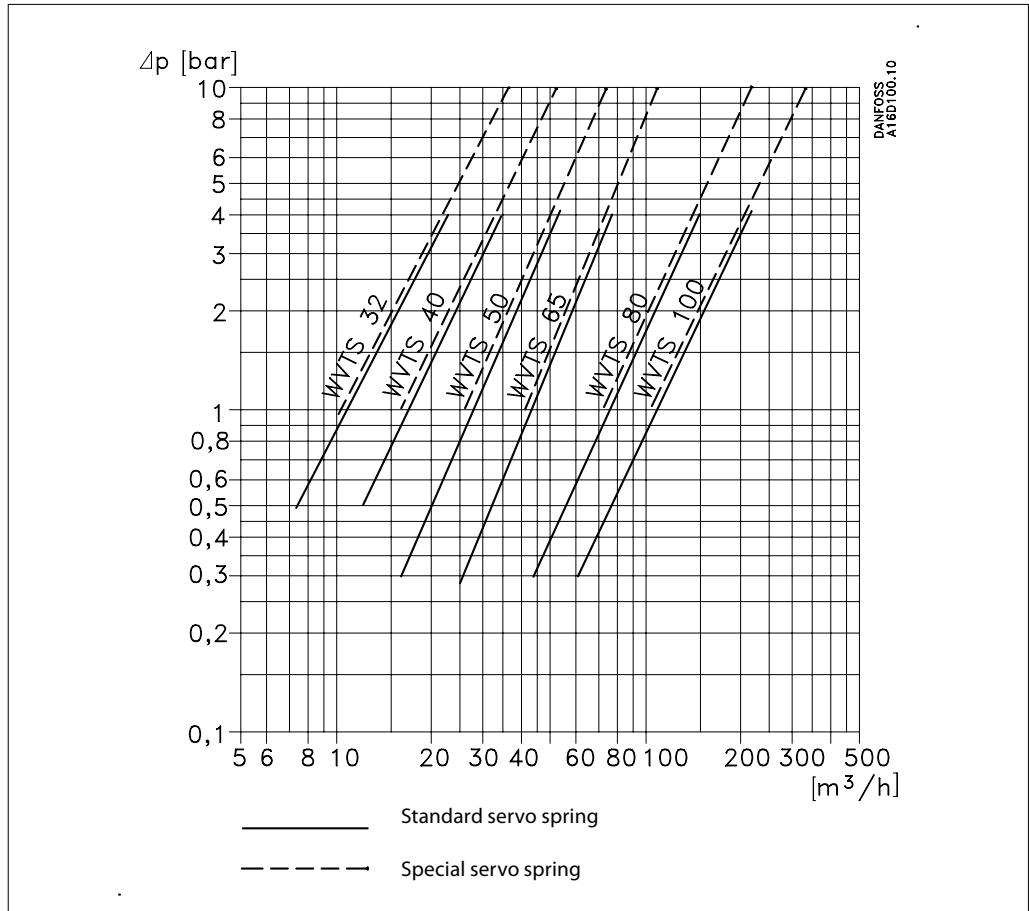

The capacity curves show the capacity (water quantity in [m^3/h]) of the individual valve sizes as a function of pressure drop across the valve.

The capacities are given for approx. 85% valve opening and are obtained with an offset of 4 °C (temperature rise at sensor) on both upper and lower temperature ranges.

Installation

Valve installation:
WVTS is to be fitted in the cooling water inlet with flow in the direction of the arrow and with the bellows element facing upwards. Horizontal mounting is a must.

Sensor / bulb installation:
The bulb is to be fitted where it is required to maintain or control the water temperature. The bulb can be fitted warmer or colder than the valve body, with no effect on the regulating capacity. The bulb must be fitted horizontally or with the blank end of the bulb at the lowest level. The capitals UP and the red line on the bulb must face upwards at horizontal or inclined fitting.

Dimensions [mm] and weights [kg]

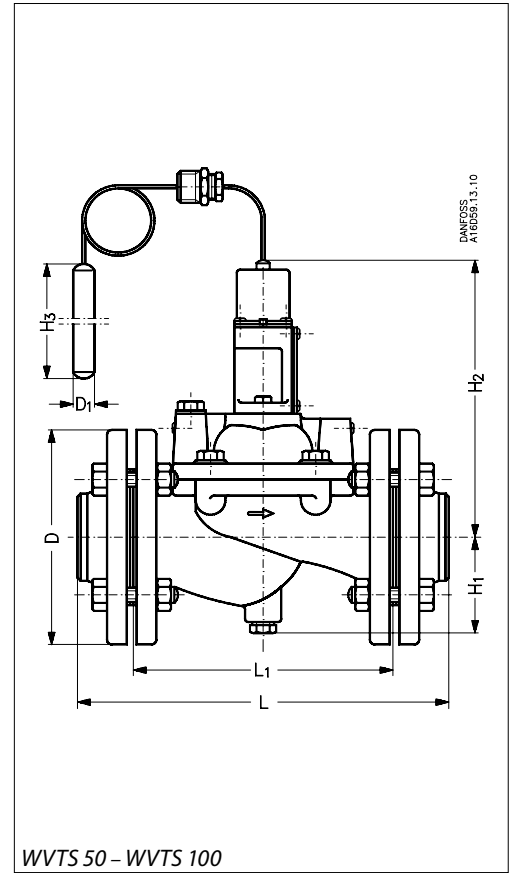
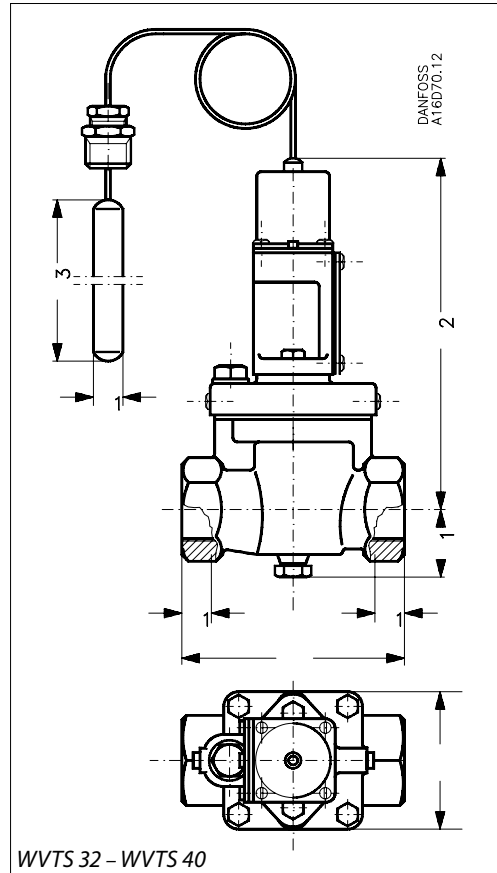

Type	H ₁	H ₂	H ₃	L	L ₁	B	øD	øD ₁	Net weight
WVTs 32	42	196	210	138	20	85	—	18	4
WVTs 40	72	224	210	198	30	100	—	18	7
WVTs 50	78	230	210	315	218	—	165	18	19
WVTs 65	82	246	210	320	224	—	185	18	24
WVTs 80	90	278	210	370	265	—	200	18	34
WVTs 100	100	298	210	430	315	—	220	18	44