

Installation guide

ELIMINATOR® Hermetic filter driers

Type DCL with access port

023R9521

023R9521

Refrigerants:
R22, R23, R32, R1234yf, R1234ze, R134a, R404A, R407A, R407C, R407F, R410A, R444B, R448A, R449A, R450A, R452A, R507 and R513A
For other refrigerants, please contact Danfoss.

Media Temperature range: -40 °C – 70 °C / -40 °F – 160 °F

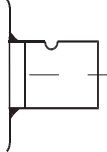
	Connection type	Core size [cu inch]	Conn. size inlet	Conn. size outlet	PS/MWP
	Solder pure copper	1.5, 03, 05	¼ inch ODF	2.8 mm ODF / ¼ inch ODF	46 bar / 667 psig
		¼ – ⅜ ODF	¼ – ⅜ ODF		

Application

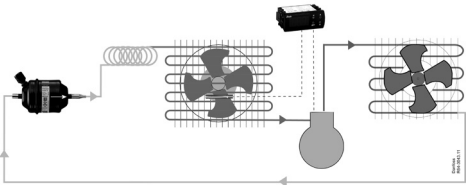

Installation

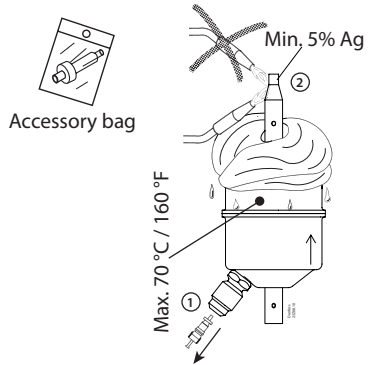

Remove Schrader valve before brazing.

Converting from capillary tube outlet 2.8 mm to ¼ inch

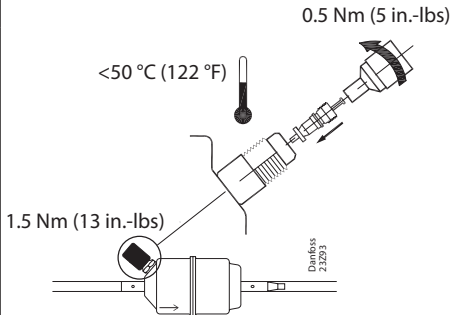
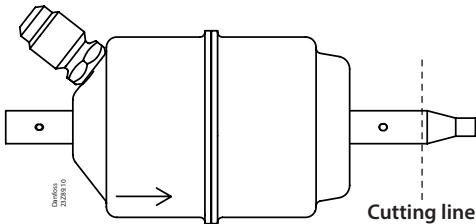

After charging, mark the system with the refrigerant and the oil type used.

If any paint is burnt off during the brazing process then clean the area and protect it with an anti-corrosion paint or heat shrink.