

avroara-arm.ru
+7 (495) 956-62-18

ENGINEERING
TOMORROW

Danfoss

Service guide

APP pumps

APP 21 - 46 and APP W HC 15 - 30

Disassembling and assembling



Table of Contents

Contents

1.	Introduction	2
2.	Disassembling the pump	3
3.	Assembling the pump	6
4.	Disassembling and assembling of the swash plate	10
5.	Disassembling and assembling of cylinder barrel and valve plate	11
6.	Disassembling and assembling of the flush valve	11
7.	Changing pistons	12
8.	When should the pistons be replaced	17
9.	Exploded view APP 21-26 , APP 30/1500 and APP W HC 15-24	18
10.	Exploded view APP 30/1200, APP 38/1500, APP 46/1780 and APP W HC 30	19

1. Introduction

This document covers the instructions for disassembling and assembling the axial piston pumps APP 21-46 and APP W HC 15-30

Tools provided with toolset 180B4172:

- 10 mm combination wrench
- 13 mm combination wrench
- 6 mm allen key
- Adjustable pin wrench
- Stop for retainer plate
- Press bush for valve plate
- Shaft seal extractor ø45
- M8 allen screw (20 mm and 140 mm)
- Press bush ø45 (Plastic)
- M8 mm eye bolt
- M8 mm nut
- M8 x 70 mm screw

Important: It is essential that the pump is serviced in conditions of absolute cleanliness.

Place the pump on a pallet or other stable surface above the ground. Ensure that the pump cannot roll. It must be possible to place the pump vertically with the shaft pointing downwards. This can be done between two pallets or between two boards on a pallet provided that the distance is minimum 50 mm.

For a better understanding of the pump, please see the exploded view on page 18 and 19.

WARNING:
Do not reuse disassembled O-rings or shaft seal as they might be damaged. Always use new O-rings.

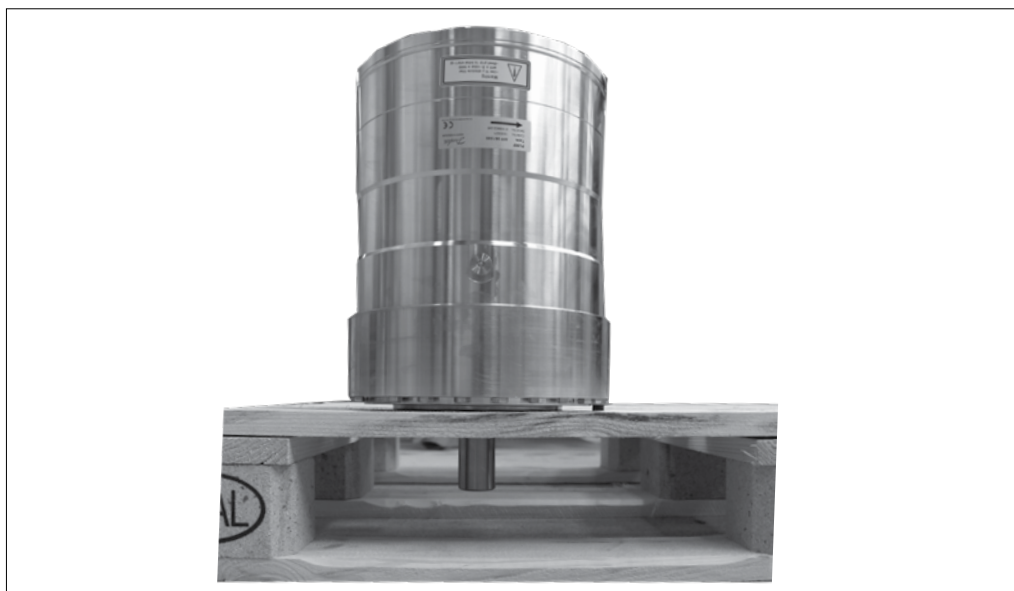

2. Disassembling the pump

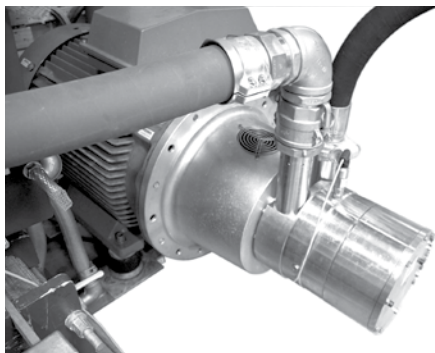

1. Disconnect the pump and motor from the system. Remove non-return valve and connector from the pump.

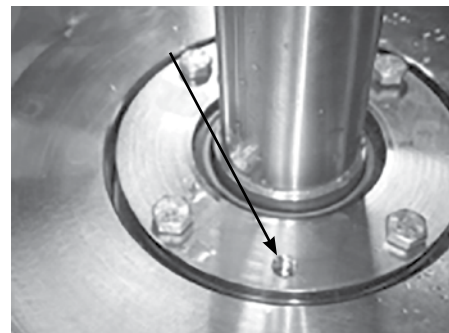

2. Using a 10 mm combination wrench, unscrew the four bolts from shaft seal flange. If shaft seal flange is stuck, screw in two bolts in holes in the flange to remove it.



3. Remove ceramic ring from flange by gently pushing it from the back of the sealing ring.



4. Mount the M8 allen screw from the tool set in the top of the shaft.
5. Wet the shaft and shaft seal with clean filtered water.

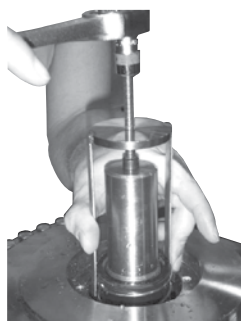

6. Carefully remove the shaft seal assembly using the shaft seal extractor supplied in the toolset. The extractor must fit underneath the shaft seal. Press the arms of the extractor together when turning the bolt.

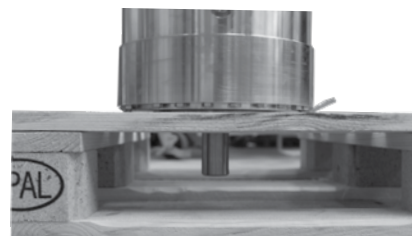

7. Turn pump into vertical position with shaft pointing downwards.

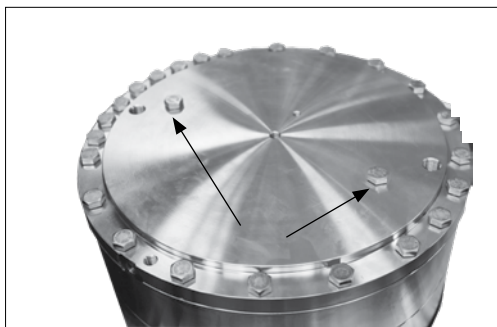

8. Using a 13 mm combination wrench, remove all the bolts on the mounting flange except the three shown in the next picture.
WARNING:
Do not loosen the two screws keeping swash plate in place.

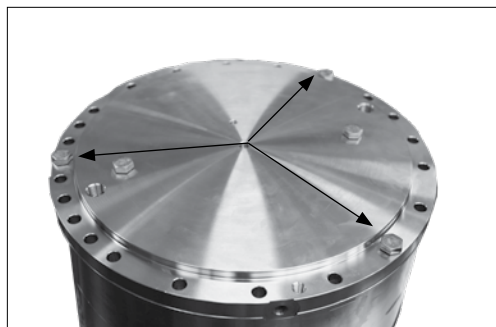

9. Unscrew the remaining three bolts. Turn each bolt one round at the time to make sure that the flange is removed as straight forward as possible.



10. Screw the eye bolt in the M8 hole in the middle of the flange. Pull it straight upwards.



11. Swash plate must be placed so that its surface is not scratched. For further disassembling of swash plate, see page 10.



12. Remove by hand the pistons one by one. Be careful not to scratch the pistons. Tilt the retainer plate to horizontal position for easy removal of pistons, if required.
WARNING:
Do not use any tools.



13. Remove the retainer plate and the retainer ball.
Warning: So not loosen the three screws in the retainer plate.



14. Remove the retainer guide, the 4 springs and the spring guide.



15. Mount a 8 mm eye bolt in the cylinder barrel. Pull straight upwards. A continuous lift will elevate the cylinder barrel out of housing. This can only be done if shaft seal is removed.

WARNING:
If the cylinder barrel is dropped or lowered too fast into housing, the main bearing/shaft bearing might be damaged. It is not replaceable.



16. Place cylinder barrel upside down. For further disassembling of cylinder barrel and valve plate see page 11.

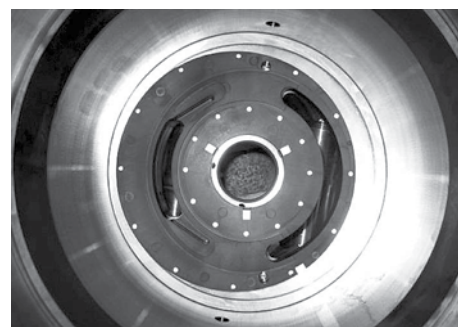

17. Remove the port plate by hand.

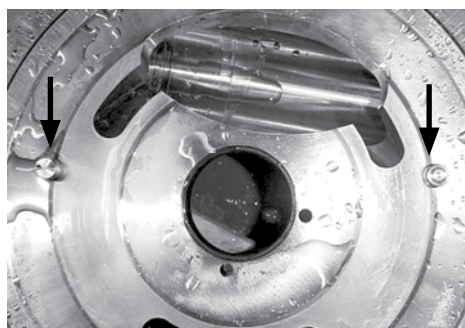

18. Remove, by hand, the two pins.
Note: The following operation is only necessary if O-ring on port flange is to be changed.



19. Place the pump horizontally.
20. Remove the remaining screws in port flange by using a 13 mm combination wrench. Carefully separate house and port flange. Ensure that pin for the positioning house is not lost.
21. For further disassembling of flush valve, see page 11.

3. Assembling the pump

WARNING:
Do not use silicone when assembling the pump. Do not reuse disassembled O-rings; they might be damaged. Always use new O-rings.

Note:
Place the pump on a pallet or other stable surface above the ground. Ensure that the pump cannot roll. It must be possible to place the pump vertically with the shaft pointing downwards. This can be done between two pallets or between two boards on a pallet provided that the distance is minimum 50 mm.

Important:
It is essential that the pump is serviced in conditions of absolute cleanliness. All parts must be absolute clean before mounting.



1. Lubrication:

- To prevent seizing-up, lubricate all threads with PTFE lubrication type.
- O-rings inside pump may be lubricated only with clean filtered water.
- O-rings for port flange, mounting flange and flushing valve must be lubricated.
- It is important to lubricate ALL parts to be assembled with clean filtered water (Especially all PEEK parts).



2. Place port flange with O-ring pointing upwards.



3. Mount O-ring.
4. Insert pin for positioning housing on port flange. Ensure that two screw holes can be reached from below.



5. Position housing aligning pin hole over guide pin.
6. Gently press downwards. Be careful not to squeeze O-ring. If O-ring is damaged, the pump will leak.
7. Screw in at least two screws.



8. Place housing horizontally. Screw in the rest of the screws on port flange. Tighten screws to a torque according to exploded view.

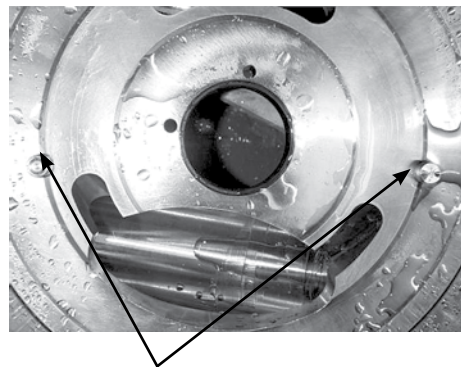

9. Place pump vertically. Place 10.5 mm pins in port flange.
10. Position port plate by using the two pins. Do not use force for this operation.

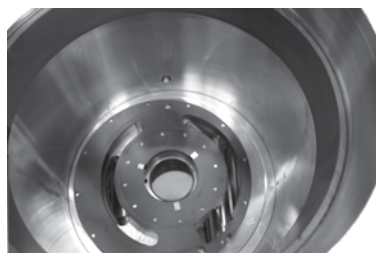

11. Ensure port plate is fitted tightly against the bottom.
IMPORTANT:
Lubricate port plate with clean filtered fresh water.
If valve plate is disassembled from cylinder barrel please see page 11 before continuing.



12. Screw eye bolt in cylinder barrel.
13. Make sure there is enough free space for the shaft beneath the housing. Gently lower cylinder barrel into housing.
WARNING!
If cylinder barrel is dropped or lowered too fast into housing, main bearing and shaft bearing might be damaged. Replacement can only be done at Danfoss, Nordborg.



14. Unscrew M8 eye bolt.
15. Place the four springs and spring guide in cylinder barrel. Springs must be positioned in the holes.



16. Retainer guide, retainer ball and retainer plate must be mounted as indicated in below picture.



17. Place retainer plate in cylinder barrel.
Note: If pistons are replaced, place new pistons in clean filtered water for a couple of minutes. Exercise piston shoes to make them "run" smoother.



19. Place pistons in retainer plate and cylinder barrel.
When pistons are placed, tilt retainer plate for easier placement of swash plate.
If swash plate has been disassembled from mounting flange, see page 10 for assembly of swash plate.
20. Lubricate piston shoes and swash plate with clean filtered water. Remember to place the pins in housing.
21. Place the pins in the housing.

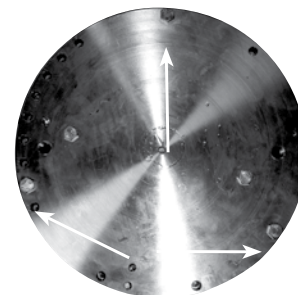

22. Place the mounting flange.
Remember to place the guide pin in the housing.
Place three bolts in mounting flange.
Turn each bolt one round at a time to ensure mounting flange is mounted as straight downwards as possible. Be careful not to squeeze O-ring.



23. Screw in the rest of the bolts and cross tighten all screws to a torque according to exploded view.

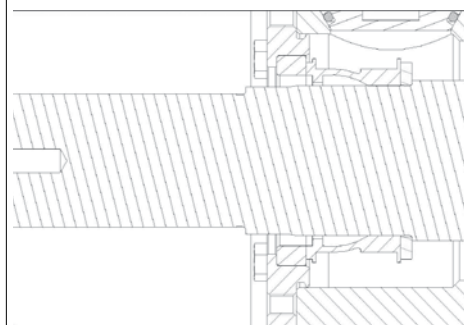

24. Place pump horizontally to get access to shaft.

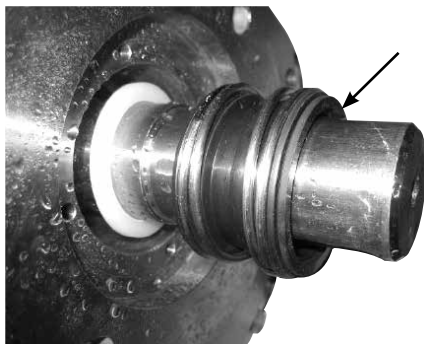

25. Lubricate shaft with clean filtered water.
26. Place stop for shaft seal on shaft.

WARNING:
Ensure that carbon ring is pointing outwards.



27. Use plastic assembly tool provided with large diameter pointing downwards, to press seal home against shoulder of stop for shaft seal.



28. Press new ceramic ring into retainer ring by using plastic tool provided.

WARNING:
Ensure that the face with rubber seal is positioned against shoulder in shaft seal flange.

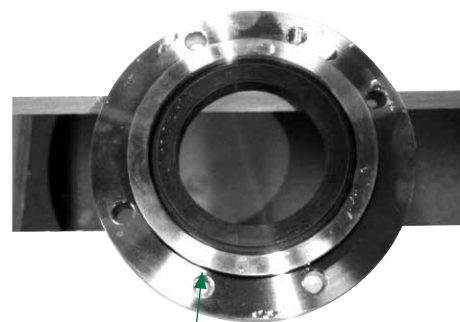

29. Remove old O-ring and fit new one on shaft seal flange.



30. Place shaft seal flange on shaft. Tighten the bolts with a torque according to exploded view.

4. Disassembling and assembling of the swash plate

WARNING:
Make sure that the surface on the swash plate does not get any marks.

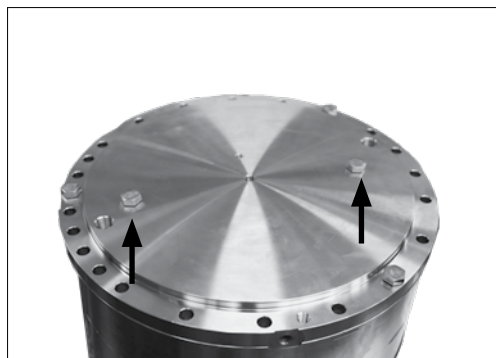

1. Place the swash plate upside down. Remove the 2 bolts holding the swash plate. Remove the mounting flange from the swash plate.

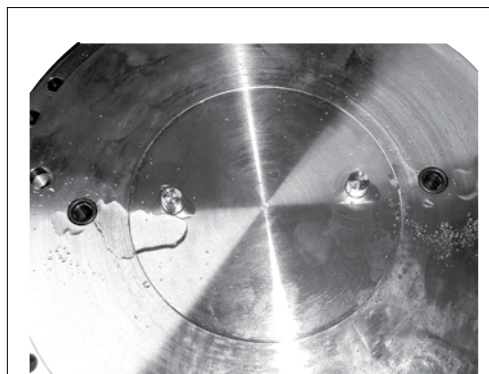

2. Check that the O-ring and pin are in good condition (provided with seal set).



3. Change the O-ring on the mounting flange.

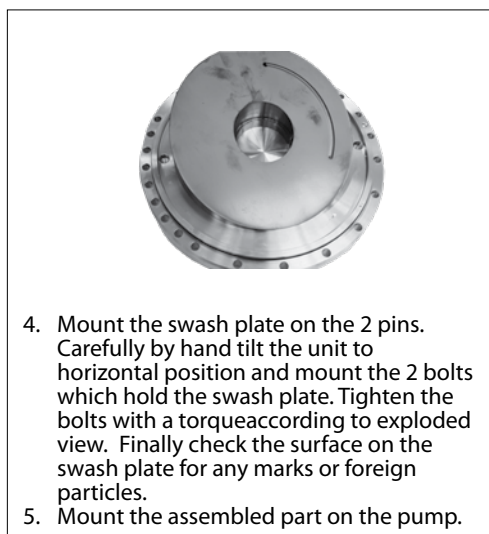

4. Mount the swash plate on the 2 pins. Carefully by hand tilt the unit to horizontal position and mount the 2 bolts which hold the swash plate. Tighten the bolts with a torque according to exploded view. Finally check the surface on the swash plate for any marks or foreign particles.
5. Mount the assembled part on the pump.

5. Disassembling and assembling of cylinder barrel and valve plate



1. Push a screwdriver into the hole between cylinder barrel and valve plate. Carefully push downward the screwdriver so that it makes a gap between cylinder barrel and valve plate. Use this gap to put in another screwdriver and loosen the valve plate from the cylinder barrel.

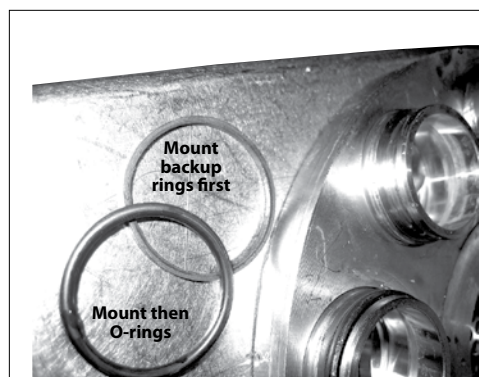

2. Remove the O-rings and backup rings. If they have been removed they can not be reused. Mount the new back-up rings on the valve plate first and then mount the O-rings.



3. Lubricate the new O-rings/back-up rings and the liners in the cylinder barrel with clean filtered water. Lower the valve plate upside down on the cylinder barrel. Place the press bush for valve plate (provided in tool set) like on the picture. Screw the bolt into the shaft of the cylinder barrel. Turn the nut slowly clockwise. The valve plate must slide carefully into the cylinder barrel. Stop when the gap between cylinder barrel and valve plate is 1-2 mm.



4. Remove the press bush again by screwing the nut counter-clockwise. Turn the nut slowly clockwise. The valve plate must slide gently into the cylinder barrel. Stop when the gap between cylinder barrel and valve plate is 1-2 mm.

6. Disassembling and assembling of the flush valve

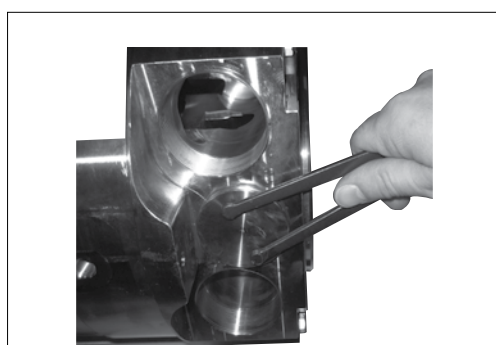

1. Unscrew the flush valve counter-clockwise by using a pin wrench.

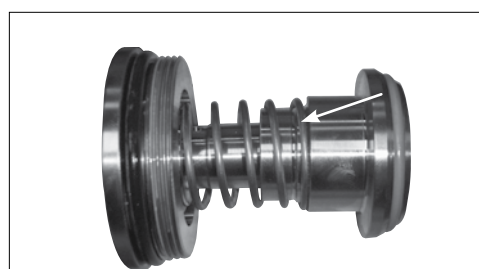

2. Remove the O-rings (green and black). If necessary, change the valve cone, spring and plug. If the spring is changed it is important that it is located like on the picture. The end of the spring must be against the shoulder of the valve cone.
3. Put a little amount of grease on the thread on the plug. Screw it into the port flange. Tighten with a torque according to exploded view.

7. Changing pistons

Tools needed are:

- 13 mm combination wrench
- 6 mm allen key:
-
- Service kit - see parts list 521B0941

7.1 Disassembling



1. Disconnect the pump from the rest of the system.
Warning:
Never unscrew the 4 screws marked with coloured sealer.

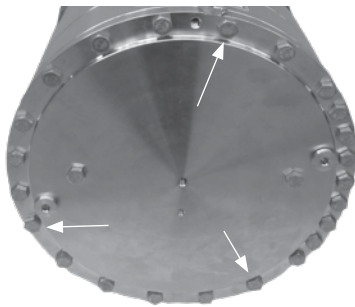

2. Loosen all screws on the pump except the three screws as shown above.
Note:
There is still water inside the pump.



3. Mount the guide bolt in the top hole.

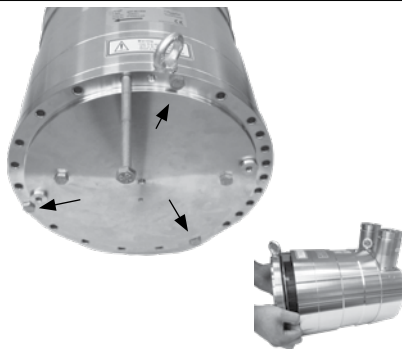

4. Unscrew the remaining three screws by using the combination wrench to turn each screw a couple of rounds at a time so the flange is removed as straight forward as possible..

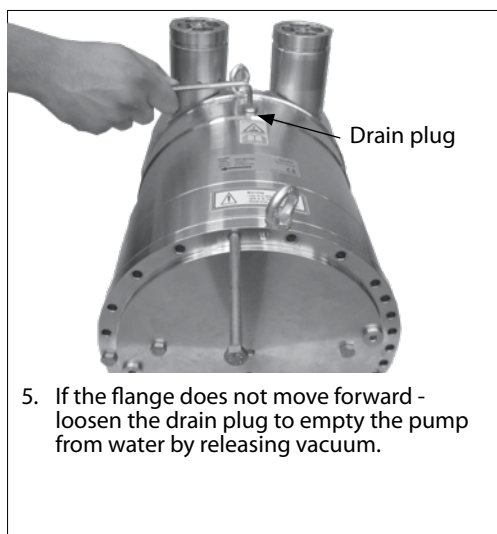

5. If the flange does not move forward - loosen the drain plug to empty the pump from water by releasing vacuum.

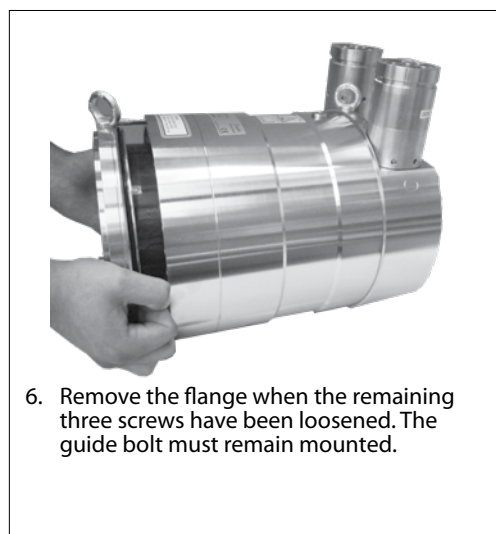

6. Remove the flange when the remaining three screws have been loosened. The guide bolt must remain mounted.

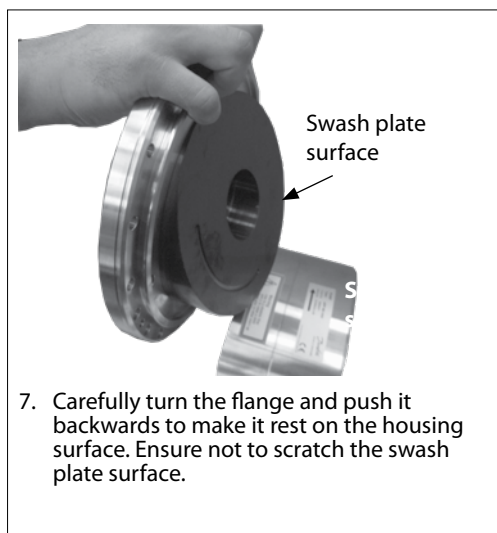

7. Carefully turn the flange and push it backwards to make it rest on the housing surface. Ensure not to scratch the swash plate surface.

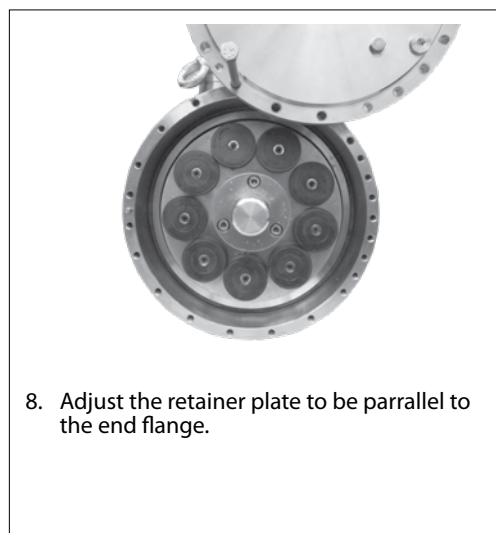

8. Adjust the retainer plate to be parallel to the end flange.

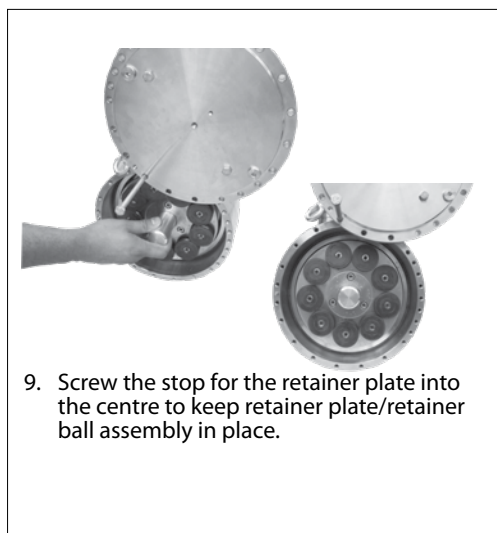

9. Screw the stop for the retainer plate into the centre to keep retainer plate/retainer ball assembly in place.

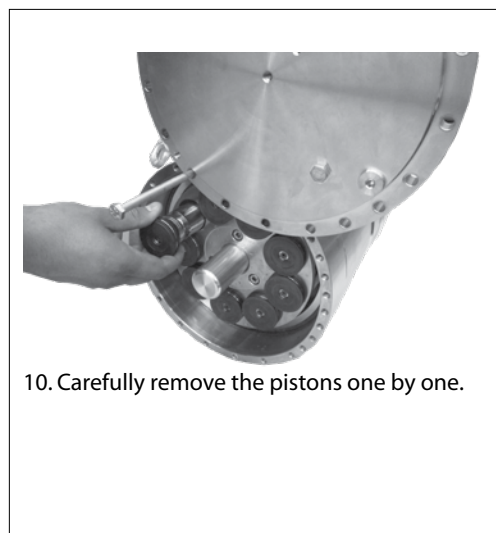

10. Carefully remove the pistons one by one.



11. **Warning:**
Ensure that the piston shoes and the piston surfaces are not damaged during removal. It is recommended to place the pistons upside down on an even and clean base/surface.

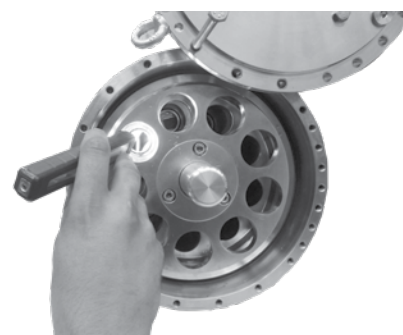

12. Inspect the piston liners.
Replace any worn parts.

7.2 Assembling

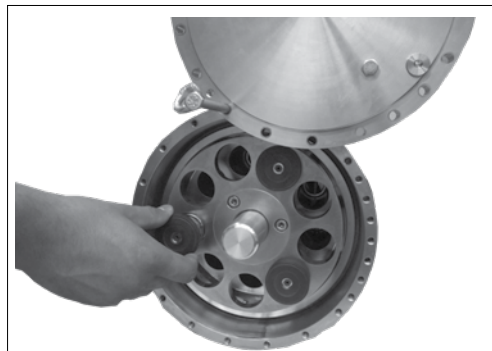

1. Lubricate pistons with clean filtered water. Insert the pistons arbitrarily.

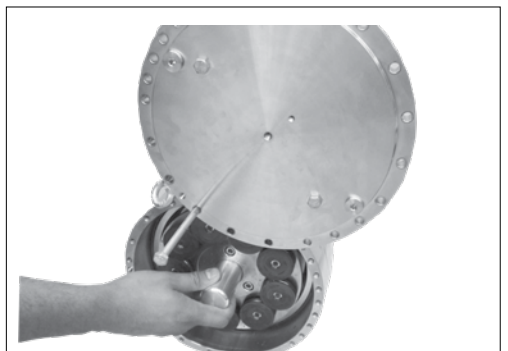

2. Remove the stop for retainer plate.



4. Place the retainer plate in an angle corresponding to the orientation of the swash plate.

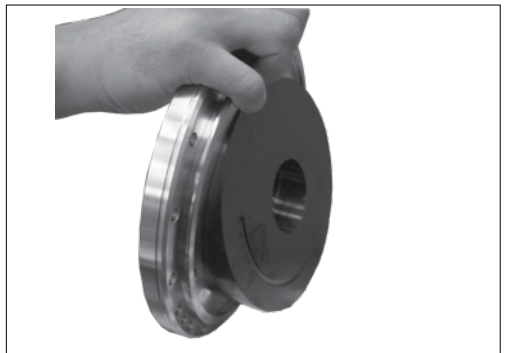

5. Tilt the flange and replace the flange O-ring.

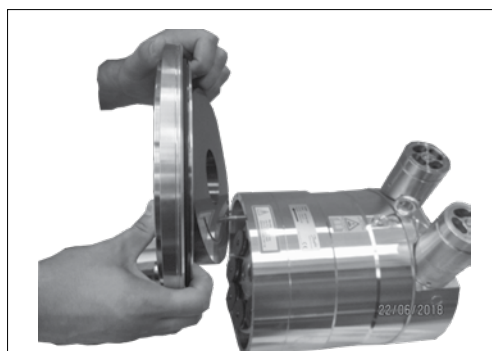

6. Turn the flange and gently push it into the housing.

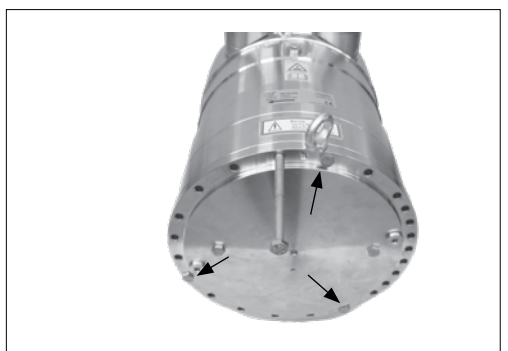

7. Mount the three screws as shown above. Tighten them to a torque according to exploded view.

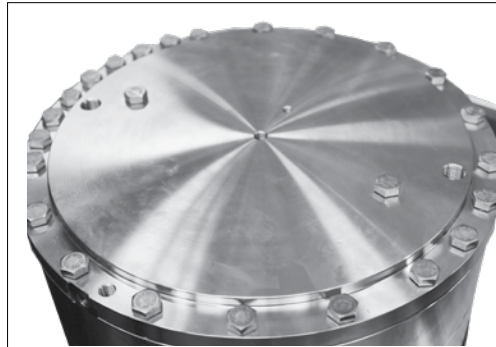

8. Remove the guide bolt.
Mount the remaining screws and cross tighten them to a torque according to exploded view.

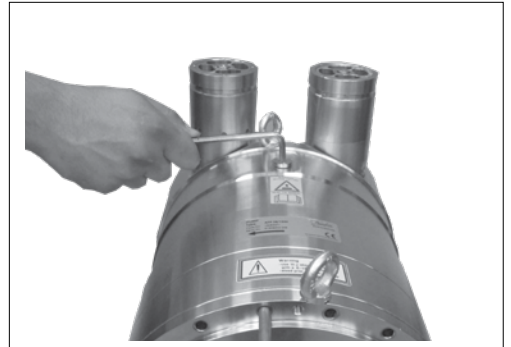

9. Connect the pump to the rest of the system and bleed the pump.

8. When should the pistons be replaced

This section provides guidance on, how to determine whether the parts of APP 21-43 are worn and should be replaced. In case of doubt - the pistons must be replaced. The pictures below are ment as a guideline for evaluating the wear of the sliding surface.

Note:
If the pistons break down, the pump will suffer a disastrous breakdown.

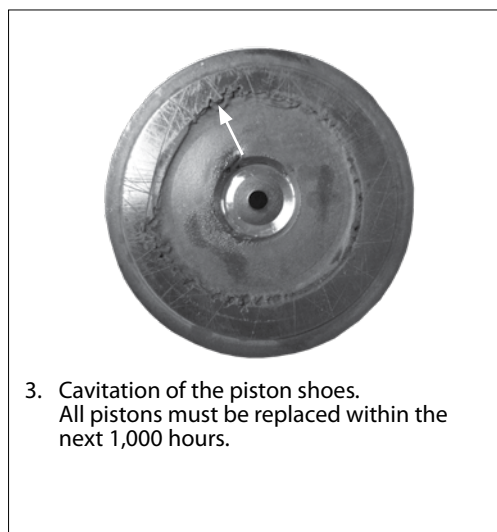
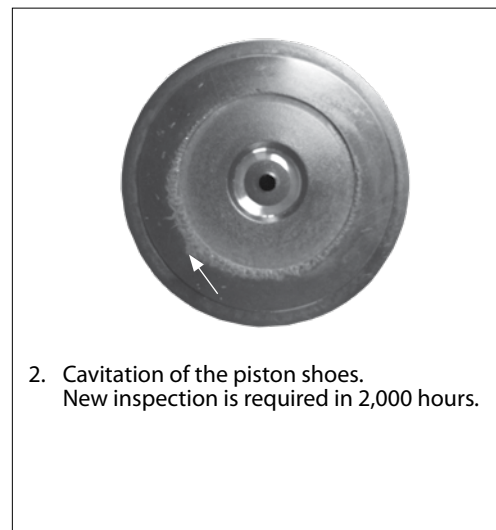
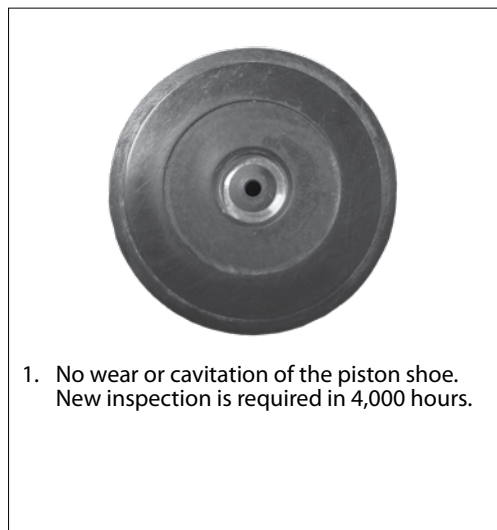

9. Exploded view
APP 21-26, APP 30/1500 and
APP W HC 15-24

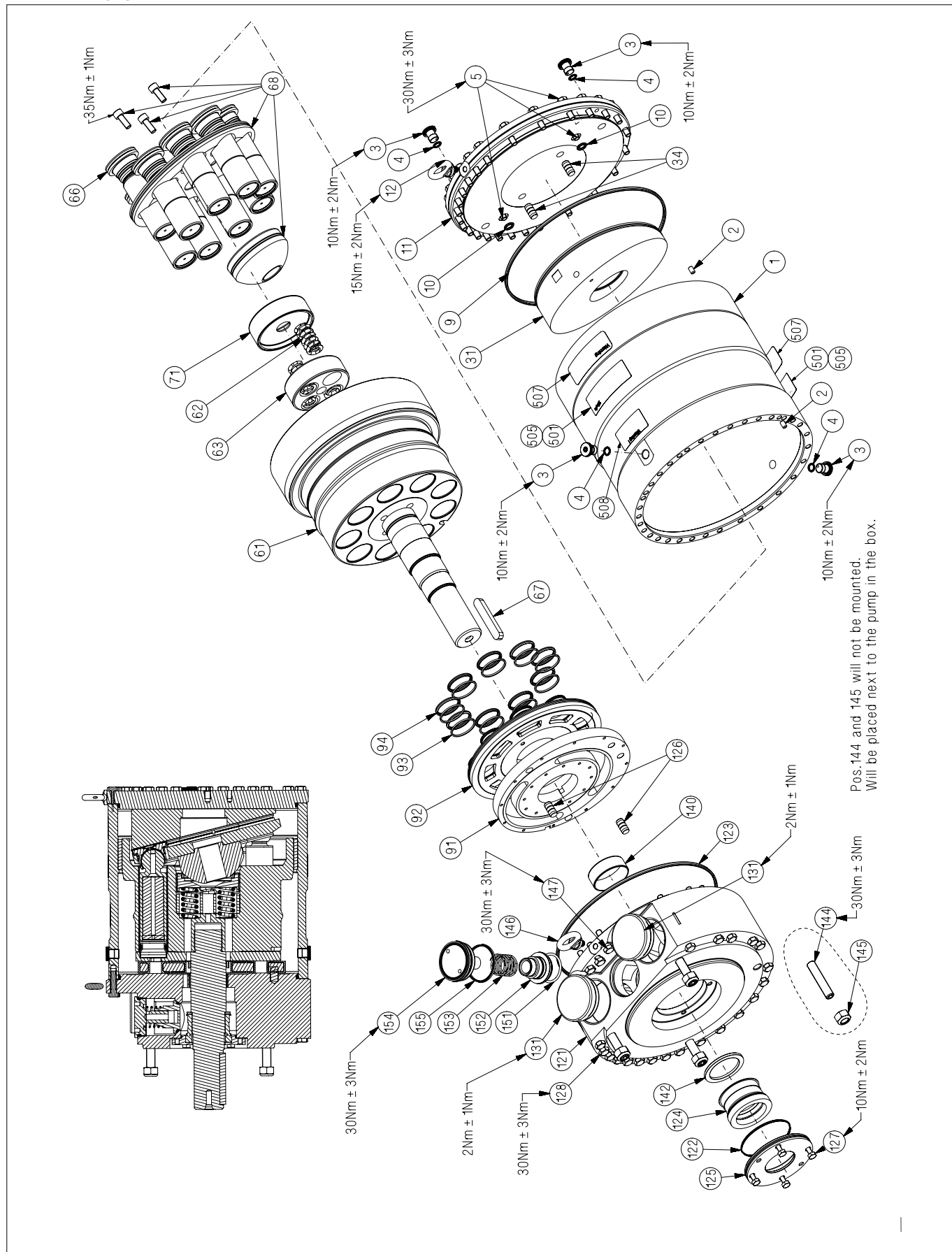

10. Exploded view
APP 30/1200, APP 38/1500, APP 46/1780 and APP W HC 30

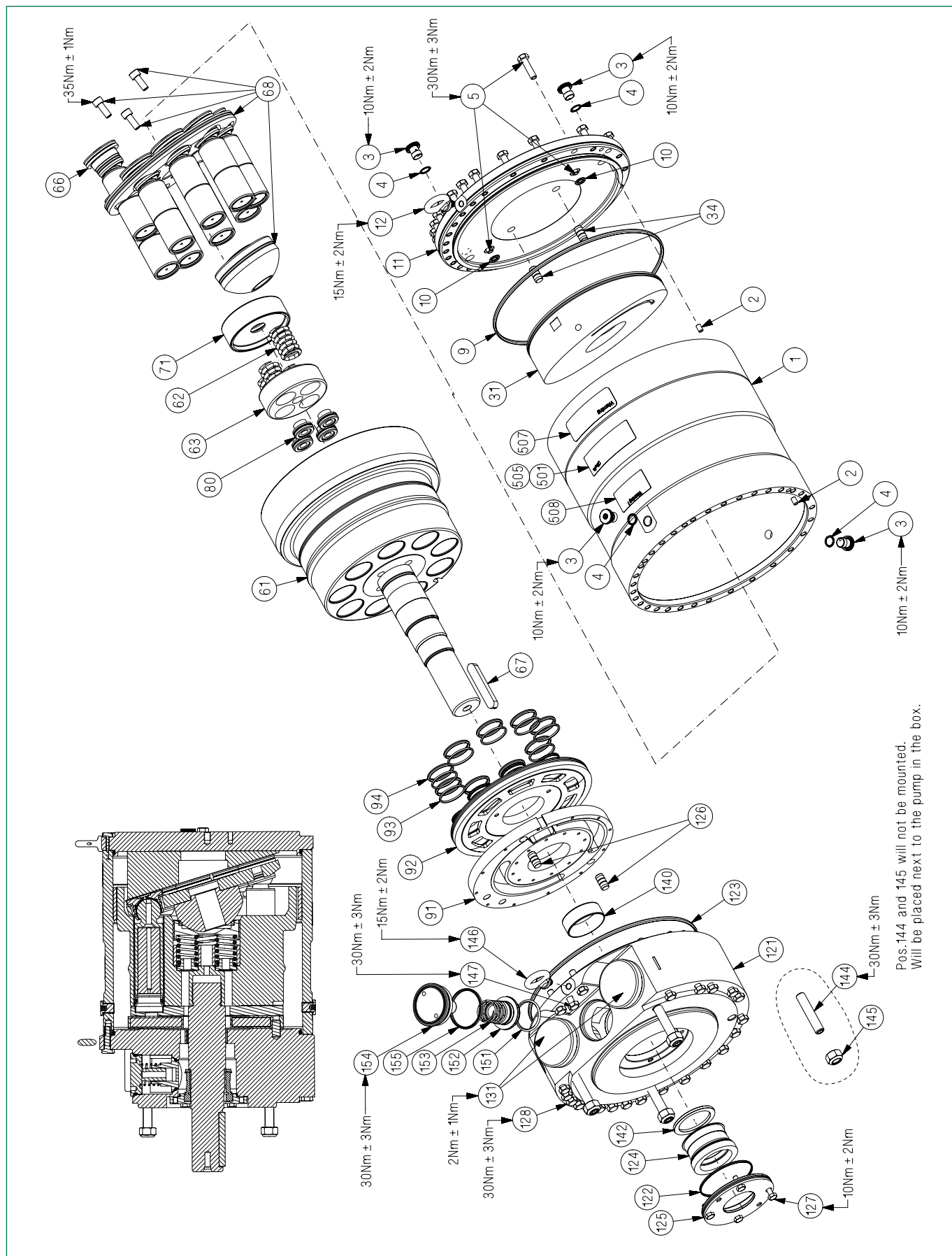

avroara-arm.ru
+7 (495) 956-62-18

ENGINEERING
TOMORROW



Danfoss can accept no responsibility for possible errors in catalogues, brochures and other printed material. Danfoss reserves the right to alter its products without notice. This also applies to products already on order provided that such alterations can be made without subsequential changes being necessary in specifications already agreed. All trademarks in this material are property of the respective companies. Danfoss and the Danfoss logotype are trademarks of Danfoss A/S. All rights reserved.
