

Data sheet

Cartridge pressure switch

Type ACB and CCB



Pressure controls ACB and CCB are compact disc type pressure switches with fixed set-points for long-standing use in refrigeration and air conditioning systems. They provide automatic or manual reset limit protection.

The small size, lightness and high degree of protection means that it can be mounted directly on the refrigeration systems.

The cartridge switch is available with different pressure settings and pressure connections to suit customer requirements.

All these features reduce installation costs and save space.

Features

- Wide range
- Fixed pressure set points
- Normally Closed, Normally Open or SPDT contact system
- Automatic or manual reset
- Various port fittings for soldering or direct mounting
- Spades or cables
- Stripped ends or customer specific electrical plug
- Open or water-proof (IP65) version
- Type ACB for use as high and low pressure cut in and cut out as well as fan cycling
- Type CCB available for CO₂ refrigerants
- Compact design and easy to install

Approvals

- CE according to EN 12263
- Technical Inspection Association TÜV TUV certificate no. 01 202 931/Q-04 0018 and 01 202 971/B-17-0002
- Low Voltage Directive 2014/35/EU
- UL recognized (type ACB only):
 - UL 873 and CSA C22.2 No. 24-93
 - UL 121201 and CSA C22/2 No.213-17 (for flammable refrigerants only)

Air conditioning and Refrigeration

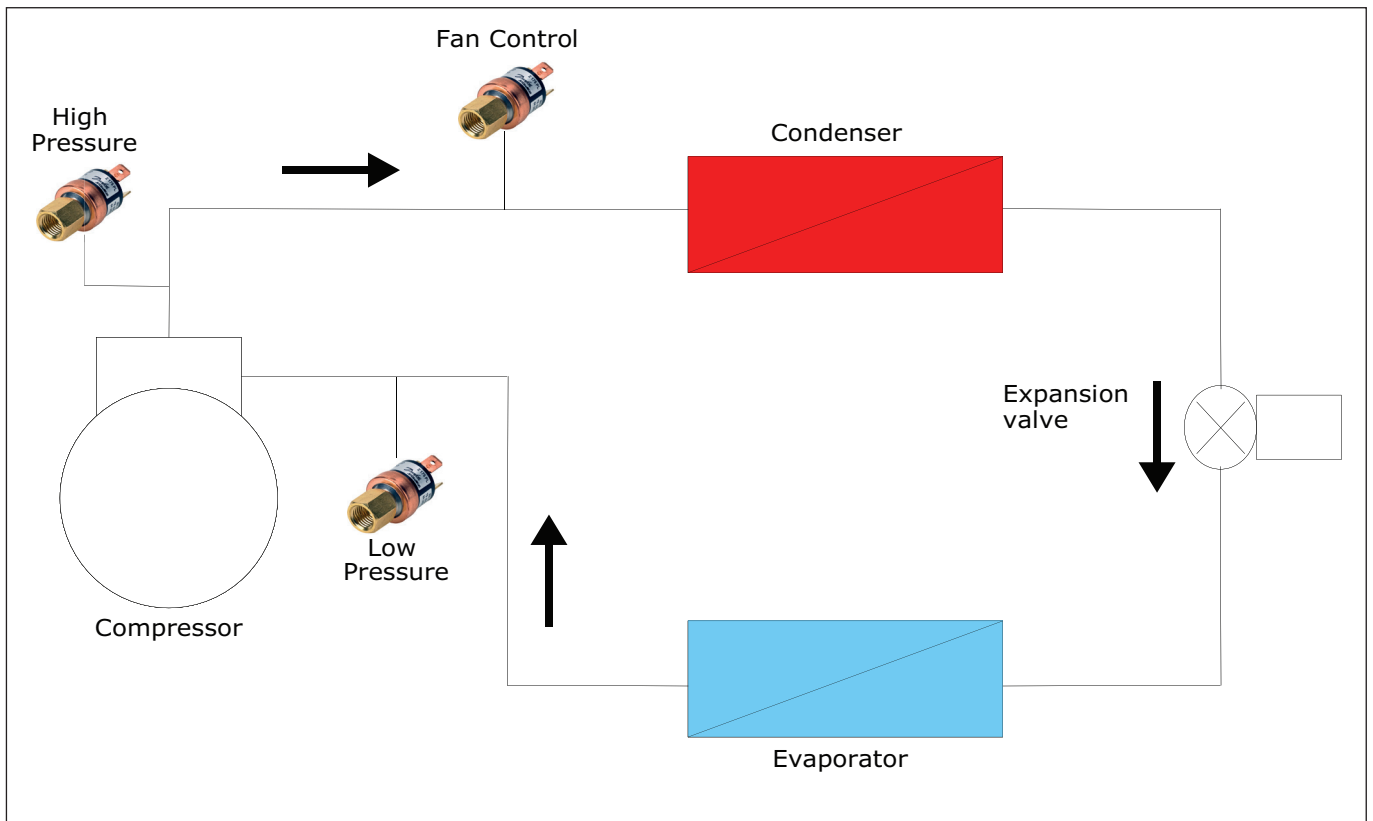

Applications

- Condenser fan switch
- Compressor stop – start
- Pump-down switch
- Low Pressure safety pressure switch
- High Pressure safety pressure switch

Technical data

Type	ACB		CCB
	Water-proof (W)	Open – spade connector (O)	Water-proof (W)
Medium	R22, R134a, R404A, R407C, R407F, R410A, R438A, R448A, R449A, R452A, R513A For flammable refrigerants please contact your nearest Danfoss office. For complete list of approved refrigerants, visit www.products.danfoss.com and search for individual code numbers, where refrigerants are listed as part of technical data		R744 (CO ₂)
Range	-0.5 – 45 bar -7 – 652 psi		100 – 150 bar 1450 – 2176 psi
Reset	Automatic, Manual	Automatic	
Contact function	SPST-NO, SPST-NC, SPDT		SPST-NC
Electrical connections	AWG18 cables	Spades (size 6.35mm x 0.8 mm)	AWG18 cables
Cable length	150 cm (black)	–	150 cm (black)
Contact load	6 A @ 250 V AC for SPST		
	4 A @ 250 V AC for SPDT		–
	0,01 - 0,05 A @ 12/24 V DC		
Pressure connections	¼ in ODM solder		6.35 mm solder
	6 mm ODM solder		
	¼ in SAE female flare		
	with depressure pin		
Maximum working pressure PS / MWP	45 bar 650 psi		165 bar 2393 psi
Burst pressure	140 bar 2030 psi		375 bar 5440 psi
Media temperature	-55 – 135 °C -67 – 275 °F		-30 – 100 °C -20 – 210 °F
Ambient temperature	-30 – 85 °C		
Enclosure	IP65	No electrical protection	IP65

Customer specific features are available in a wide selection.
Please refer to Specification Build-up on page 8.

Lifetime

Switch type:
 SPST auto reset, Normally open
 Pressure setting : max 3 MPa

As general rule, ACB pressure switches are capable to cover applications requiring cycling from 100000 to 1500000 cycles dependent on current load. The exact number of cycles in any of given application is to be determined by appropriate testing. Danfoss-Saginomiya reserves the right to change or modify specifications at any time without prior notice.

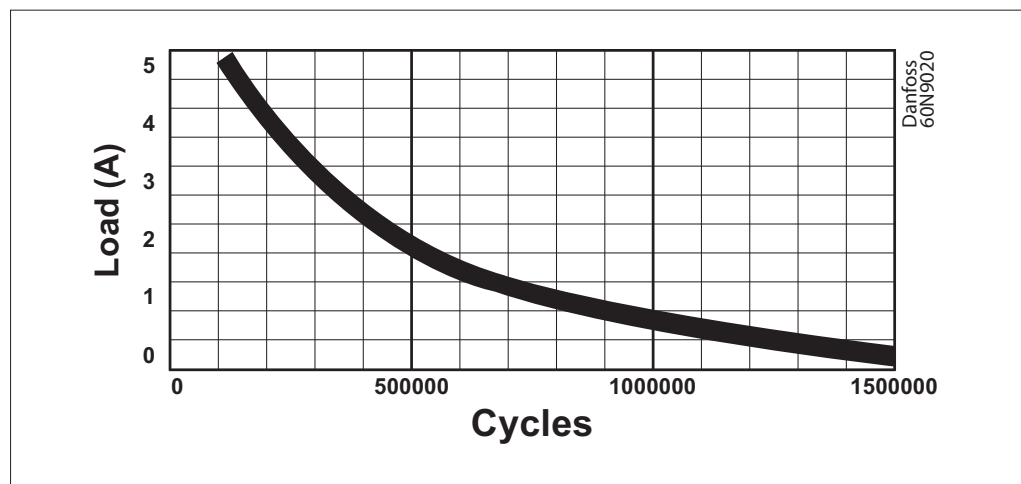

SPST auto reset, Normally close – up to 100000 cycles
 SPST manual reset, Normally close – 10000 cycles
 SPDT auto reset – up to 100000 cycles
 SPDT manual reset – 10000 cycles

Electrical connections

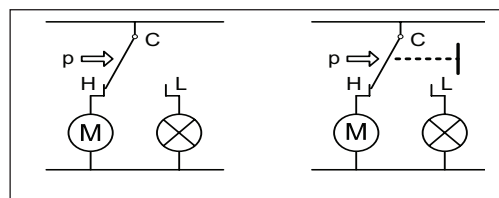

SPDT

SPDT with manual reset

SPST - Single Pole Single Throw
 SPDT - Single Pole Double Throw
 (NO) - Normally Open
 (NC) - Normally Closed

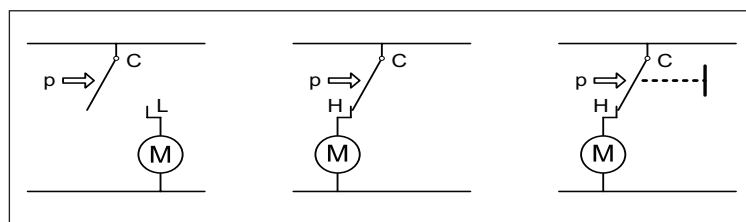

SPST NO

SPST NC

SPST with manual reset

Standard models

Type ACB



Application	Reset	Cut out [bar] [psi]	Cut in [bar] [psi]	Contact system / enclosure type W-water-proof types with cable (IP65) O-open (spade connector) types / no cable (IP00)	Connection type		
					Solder		Flare
					6 mm	¼ in	
High pressure cut out	Auto.	18 ± 0.7 260 ± 10	13 ± 1.2 190 ± 17	SPST-NC / W	061F7504 ACB-2UB504W	061F7505 ACB-2UB505W	061F7506 ACB-2UB506W
				SPDT / W	–	–	061F9057 ACB-2UC59W
		20 ± 1 290 ± 14	16 ± 1.5 230 ± 21	SPST-NC / O	–	061F8710 ACB-2UB210	061F8708 ACB-2UB208
	Auto.	23 ± 0.7 335 ± 10	19 ± 1.2 275 ± 17	SPST-NC / W	–	–	061F8494 ACB-2UB465W
				SPST-NC / O	–	061F8707 ACB-2UB207	061F8703 ACB-2UB203
				SPDT / W	–	–	061F9056 ACB-2UC58W
	Man.			SPDT / W	–	–	061F9243 ACB-2UC63MW
	Auto.	26 ± 1 380 ± 15	20 ± 1.5 290 ± 22	SPST-NC / W	061F7507 ACB-2UB507W	061F7508 ACB-2UB508W	061F7509 ACB-2UB509W
				SPST-NC / O	–	061F8705 ACB-2UB205	061F8701 ACB-2UB201
	Man.			SPST-NC / W	061F9703 ACB-2UB803MW	061F9714 ACB-2UB814MW	061F9713 ACB-2UB813MW
	Auto.			SPDT / W	–	–	061F9055 ACB-2UC57W
	Auto.			SPST-NC / W	061F7510 ACB-2UB510W	061F7513 ACB-2UB513W	061F7514 ACB-2UB514W
	Man.				–	–	061F9522 ACB-2UB327MW
	Auto.	28 ± 1 405 ± 14	21 ± 1.5 305 ± 22	SPST-NC / O	–	061F8704 ACB-2UB204	061F8700 ACB-2UB200
	Auto.			SPDT / W	–	–	061F9054 ACB-2UC56W
	Man.			SPDT / W	–	–	061F9242 ACB-2UC62MW
	Auto.	31 ± 1 405 ± 14	24 ± 1.5 350 ± 22	SPST-NC / W	061F8493 ACB-2UB464W	–	061F8492 ACB-2UB463W
				SPST-NC / O	–	061F8706 ACB-2UB206	061F8702 ACB-2UB202
				SPDT / W	–	–	061F9053 ACB-2UC55W
	Auto.	42 ± 1.2 610 ± 17	33 ± 2 480 ± 29	SPST-NC / W	061F7515 ACB-2UB515W	061F7516 ACB-2UB516W	061F7517 ACB-2UB517W
	Man.				–	–	061F9575 ACB-2UB461MW
	Auto.			SPDT / W	–	–	061F9052 ACB-2UC54W

* Other code numbers are available upon request.

Standard models
(continued)

Application	Reset	Cut out [bar] [psi]	Cut in [bar] [psi]	Contact system / enclosure type W-water-proof types with cable (IP65) O-open (spade connector) types / no cable (IP00)	Connection type		
					Solder		Flare
					6 mm	¼ in	
Low pressure control	Auto.	0.5 ± 0.4 7 ± 6	1.5 ± 0.5 22 ± 4	SPST-NO / W	061F7518 ACB-2UA518W	061F7519 ACB-2UA519W	061F7520 ACB-2UA520W
				SPST-NO / O	–	061F7402 ACB-2UA152	061F7400 ACB-2UA150
				SPDT / O	–	061F9106 ACB-2UC106	061F9102 ACB-2UC102
	Auto.	0.7 ± 0.5 10 ± 7	1.7 ± 0.4 25 ± 6	SPST-NO / W	061F7521 ACB-2UA521W	061F7522 ACB-2UA522W	061F7523 ACB-2UA523W
				SPDT / W	–	–	061F9058 ACB-2UC60W
	Auto.	1.7 ± 0.5 25 ± 7	2.7 ± 0.4 39 ± 6	SPST-NO / W	061F7524 ACB-2UA524W	061F7525 ACB-2UA525W	061F7526 ACB-2UA526W
Auto.	2.2 ± 0.3 32 ± 4.5	3.4 ± 0.3 50 ± 4.5	SPST-NO / W	061F7418 ACB-2UA711W	–	–	
Fan control	Auto.	8.5 ± 1.2 125 ± 17	11 ± 0.8 160 ± 12	SPST-NO / W	061F8491 ACB-2UA393W	–	061F8490 ACB-2UA392W
		13 ± 1.5 190 ± 22	16 ± 1 230 ± 14		061F8334 ACB-2UA306W	–	061F8333 ACB-2UA305W

Type CCB



Application	Reset	Cut out [bar] [psi]	Cut in [bar] [psi]	Contact system / enclosure type W-water-proof types with cable (IP65)	Connection type	
					Solder 6.35 mm	
					Packing 100 pcs.	Packing 20 pcs.
High pressure control	Auto.	100±10 1450±145	70±20 1015±290	SPST-NC / W	061F9808 CCB-2UB03W	061F9908 CCB-2UB03W
		110±10 1595±145	80±20 1160±290		061F9809 CCB-2UB04W	061F9909 CCB-2UB04W
		120±10 1740±145	90±20 1305±290		061F9810 CCB-2UB05W	061F9910 CCB-2UB05W
		130±10 1885±145	100±20 1450±290		061F9811 CCB-2UB06W	–
		140±10 2030±145	100±20 1450±290		061F9812 CCB-2UB07W	–
		150±10 2175±145	100±20 1450±290		061F9813 CCB-2UB08W	–

Design / Function

- 1. Wires
- 2. Reset button
- 3. Water-proof casing
- 4. Diaphragm
- 5. Pressure connection
(1/4 in female flare)
- 6. Electrical terminals
- 7. Micro-switch
- 8. Shaft
- 9. Depressure pin

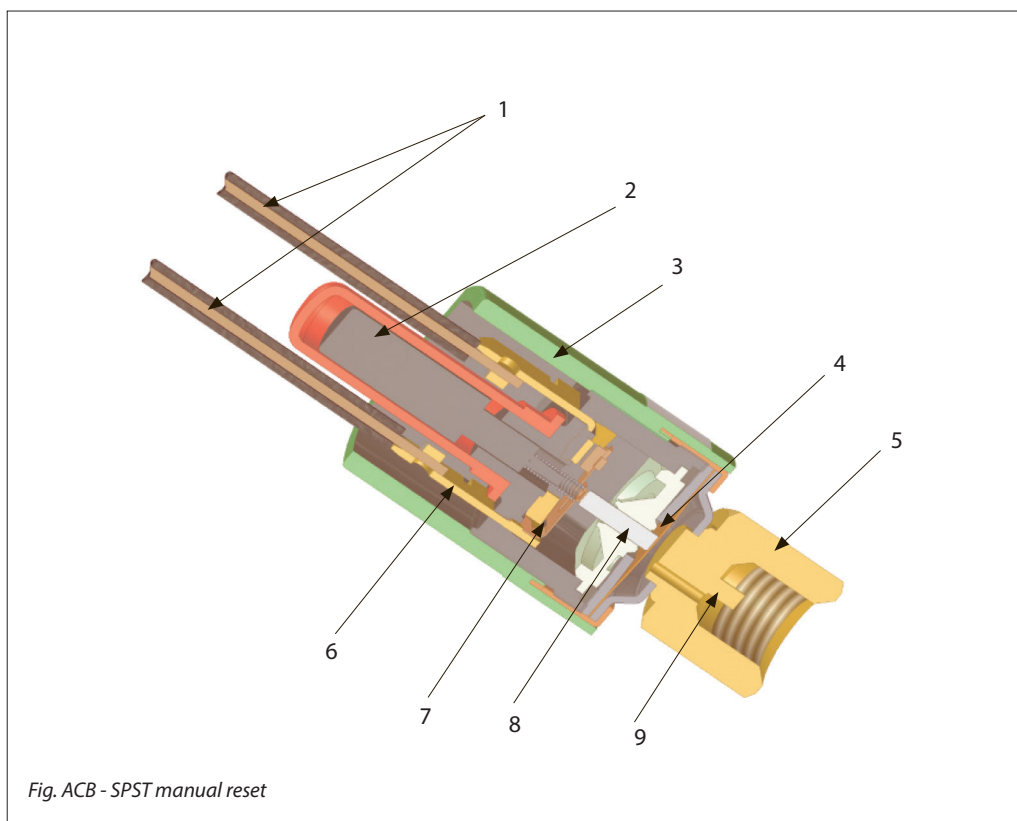

As pressure is applied through the connection on to the diaphragm, the diaphragm is pushed up against the operation shaft.

When the operation shaft rises, it pushes up the contact plate, so that contacts become connected (in normally open) or disconnected (in normally closed).

As the pressure in the connection decreases, the diaphragm returns to its original state, and the operation shaft lowers, causing the contact plate to return to its original position.

Special accessories

A wide variety of cartridge switches are available with open enclosure - no electric protection. For these switches a water-proof rubber plug has been specially designed.

When the plug is installed on the switch a water-proof seal IP64 is obtained. The water-proof rubber plug is available with many different cable lengths.



Standard cable length [m]*	Packing quantity	Code no.
2.5	100	061F1302
6	100	061F1304

* other cable lengths available upon request

Specification build up
Type ACB

		Product	Electrical rating	Contact	Approvals	Enclosure	Reset	Housing	Port fitting	Upper activation setting [bar gauge]	Tolerance on upper setting [bar]	Lower activation setting [bar gauge]	Tolerance on low setting [bar]	Electrical connection	Cable length in cm	Cable plug	Mark if additional specifications	Details of special features (if any)	
Requested specs:		ACB 2U B 1 W A R L 20,0 1,0 15,0 1,5 A 100 0																	
Example:		ACB 2U B 1 W A R L 20,0 1,0 15,0 1,5 A 100 0																	
Field	Code	Explanation																	
Product																			
Electrical rating																			
	1U	1A @ 250V AC																	
	2U	6A @ 250V AC (SPST), 4A @ 250V AC (SPDT)																	
	4U	0,05A @ 12/24V DC (gold contacts)																	
Contact																			
	A	SPST-NO																	
	B	SPST-NC																	
	C	SPDT																	
Approvals																			
	0	CE [category II] approval																	
	1	CE [category II + IV], TÜV, VDE, UL & C-UL approvals (only with ACB)																	
	2	UL & C-UL approvals (only with ACB)																	
	3	CE [category II + IV] approval (only with ACB)																	
Enclosure																			
	O	Open																	
	W	Waterproof IP65 (only with cables)																	
Reset																			
	A	Automatic																	
	M	Manual (not SPST-NO; SPDT only in Panel mount housing)																	
Housing																			
	R	Regular hot-melt																	
	E	Epoxy type																	
	P	Panel mount (mandatory for SPDT Manual reset versions)																	
Port fitting																			
	M	1/4" SAE female flare w. deflator																	
	V	1/4" SAE female flare w. 1mm deflator																	
	H	1/4" SAE male flare																	
	P	1/4" solder Cu-tube (tip = 3 mm)																	
	X	1/4" solder Cu-tube (tip = 7 mm)																	
	S	1/4" solder Cu-tube (no tip)																	
	L	6 mm solder Cu-tube (tip = 7mm)																	
	E	1/8-27 NPT male																	
	Y	R (PT) 1/8"																	
Upper activation setting [bar gauge]		---																	
Tolerance on upper setting [bar]		---																	
Lower activation setting [bar gauge]		---																	
Tolerance on low setting [bar]		---																	
Electrical connection																			
	A	AWG18 cables																	
	B	AWG16 cables																	
	C	AWG18 (UL 3173) cables																	
	S	90 deg. spades																	
	D	Double insulated AWG18 cables																	
	V	Double insulated H05VV5-F 2-in-1 cable (on request only, E housing only, Automatic reset only)																	
	R	Double insulated H05RNF 2-in-1 cable (on request only, E housing only, Automatic reset only)																	
	P	AWG18 with PVC tube																	
	H	AWG18 halogen free (RoHS compliant, currently E housing only)																	
Cable length in cm		---																	
		Please use one of standard lengths: 020, 050, 080, 100, 150, 200 & 250 cm																	
Cable plug																			
		(Leave blank if no cable)																	
	0	Cut ends																	
Faston																			
	A	A1: AMP 170213-2, A2: AMP 170213-2, A3: OBR#250, A4: AMP 735222-2+AMP 735222-2, A5: AMP 170183-2, A6: AMP 170213-2																	
AMP																			
	B	B1: AMP 350777-1, B2: AMP 282080-1, B3: AMP 282104-1, B4: AMP 192167-2, B5: AMP 881772-1, B6: AMP 174354-2																	
Molex																			
	M	M1: 5557-02R																	
Pin connector																			
	P	P1: Phoenix 3200250, P2: AMP 350218-1, P3: AMP 170213-2+AMP 926933-1, P4: AMP 926882-1, P5: AMP 165590-1																	
Packard																			
	Q	Q1: 12010973, Q2: 12015792, Q3: 15300002, Q4: 15300027, Q5: 12020829																	
Stripped end																			
	S	S1: stripped ends 15mm, S2: stripped ends 10mm																	
VHR																			
	V	V1: VHR-2N, V2: VHR-3N																	
WAGO																			
	W	W1: 231-302/026-000, W2: 769-102/021-000																	
Additional features																			
		Leave blank if no additional specifications																	
	X	Please specify (clear text attachment)																	
Details of special features (if any)																			

Dimensions [mm]
and weights [kg]

Type ACB – SPST water-proof with automatic reset ¼ in solder type

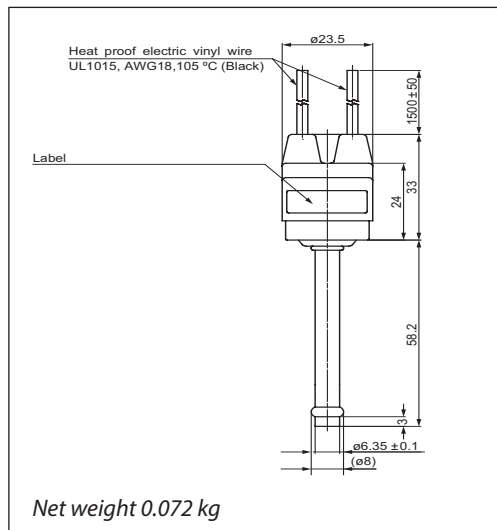

Type ACB – SPST water-proof with automatic reset female flare

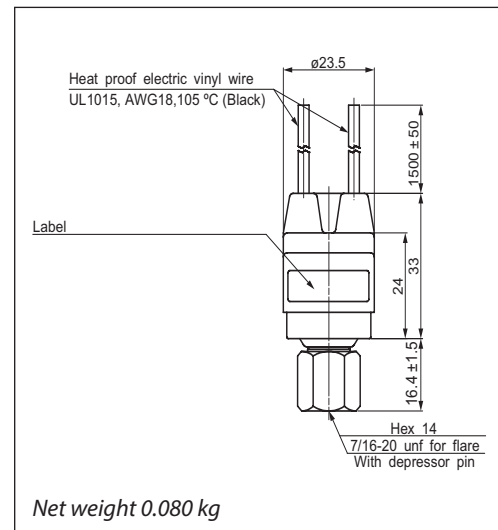

Type ACB – SPST water-proof with manual reset solder type

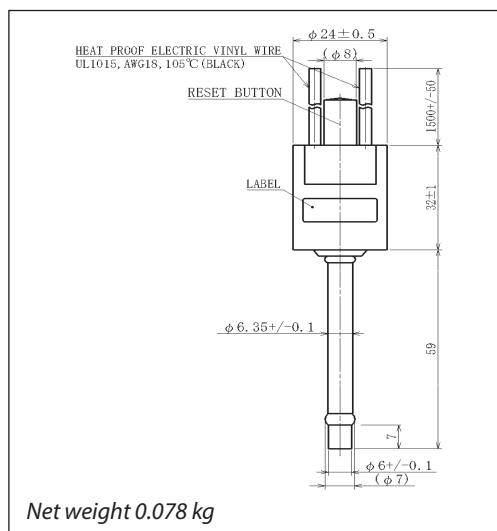

Type ACB – SPST water-proof with automatic reset 6 mm solder type

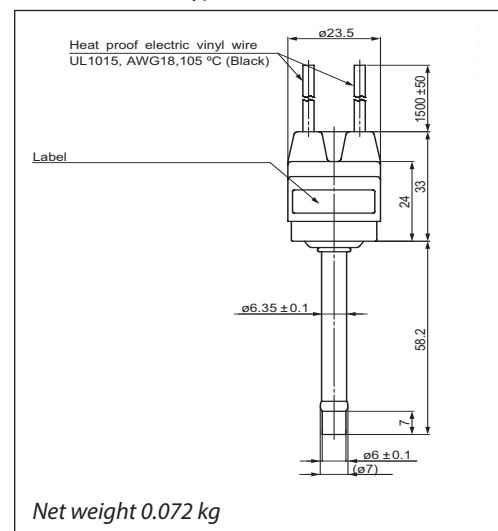

Type ACB – SPDT with automatic reset

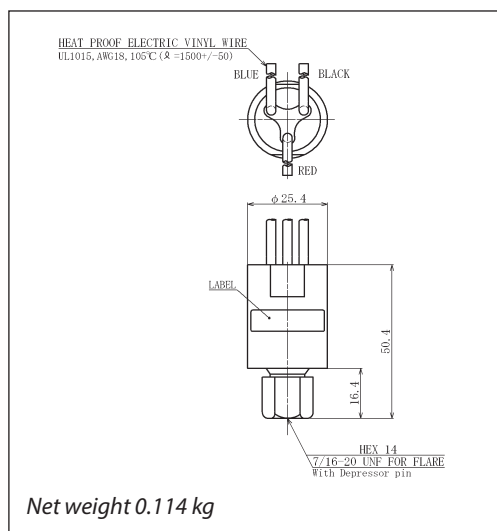

Type ACB – SPDT with manual reset

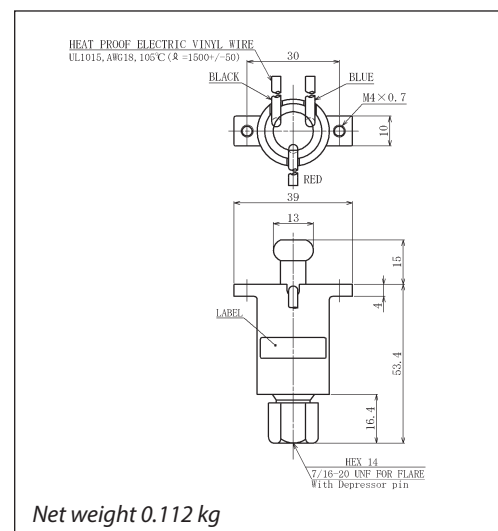

**Dimensions [mm]
and weights [kg]**
(continued)

Type ACB – SPDT open type solder type

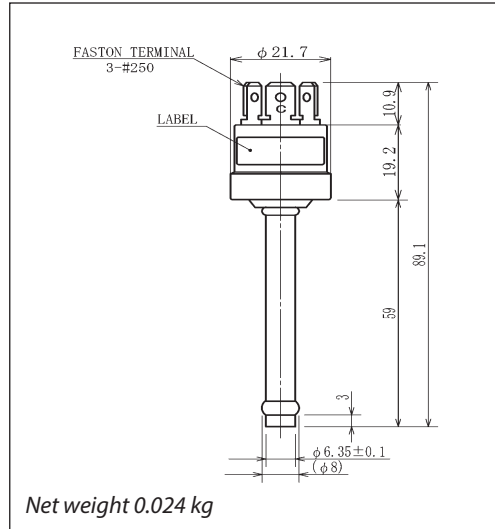

Type ACB – SPST open type with female flare

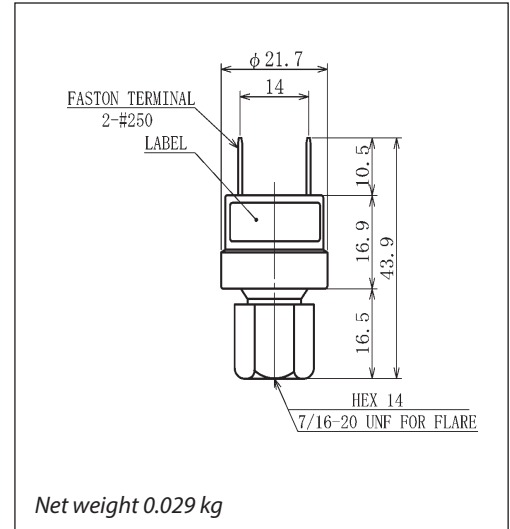

Type CCB - SPST water-proof with automatic
reset 6.35 mm solder type

