

Data sheet

Oil Pump type BFP 21 LE-S - size 3 and 5

Application

BFP 21 LE-S oil pumps are designed for small/ domestic oil burners up to 42 l/h.

BFP 21 LE-S features:

- Light oil and kerosene
- 1 or 2-pipe operation
- 1-stage
- Solenoid valve cut-off
- Cartridge filter
- Low emission at start and stop

Function

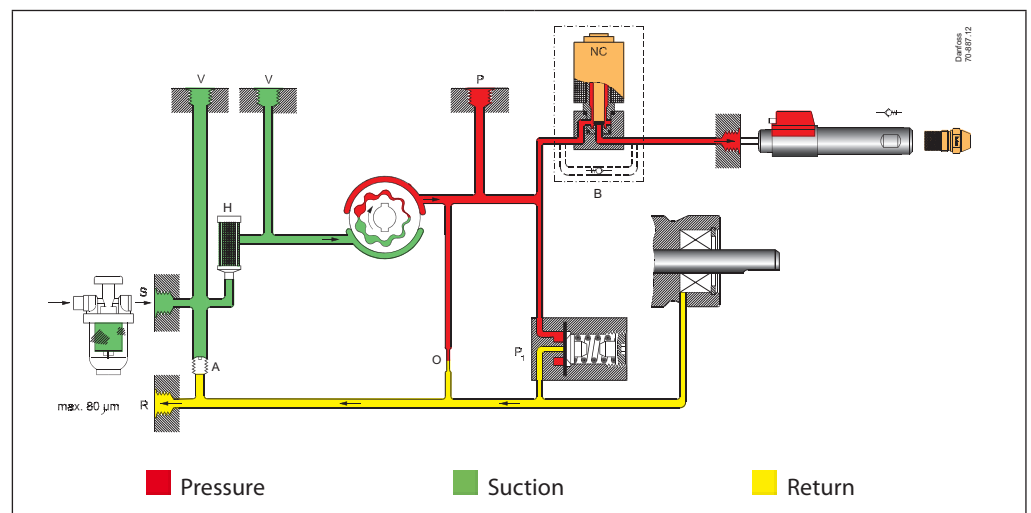

Before the burner starts the oil is heated in the oil preheater and in the nozzle line. This causes the oil to expand. The safety shut-off valve in the preheater prevents the oil from dripping out of the nozzle because the check valve B in the solenoid valve opens and thus makes a connection to the return or suction side of the pump.

The preheater valve opens at a pressure ≥ 6 bar. The check valve B in the solenoid valve NC opens at a pressure of max. 2 bar. When the burner starts the required atomizing pressure in the pump is built up and this pressure ensures that the check valve B closes and remains closed during the whole operating period. The pressure in the pump will always be \geq the pressure in the nozzle line.

When the burner stops and the pressure in the pump drops to suction pressure, the LE-S system may again become active if the nozzle and preheater are heated due to radiation from the boiler or due to residual heat in the preheater.

If the pump is used without a shut-off valve in the preheater, the valve B in the solenoid valve will never become active and thus there will be no risk that, even with an overlying tank, the oil is released to the combustion chamber unintentionally.

When the burner stops, the voltage to the NC-valve is cut off and the oil flow to the nozzle outlet is cut off immediately.

Bleeding

In 2-pipe systems the pump is self-priming, i.e. bleeding is performed via the constriction (O) to the return outlet (R).

In 1-pipe systems with plugged return outlet (R), bleeding must be performed through the nozzle outlet (E) or the pressure gauge port (P).

Warranty

For pumps used outside the stated technical data and used with oil containing abrasive particles Danfoss cannot give any warranty.

Note!

Do not mount the pump with the solenoid valve pointing downwards.

The solenoid valve must be replaced after 250.000 operations or 10 years (approved life expectancy).

Identification

BFP	2	1	L	5	L	LE-S
						R: right hand nozzle outlet
						L: left hand nozzle outlet
						3: capacity 24 l/h
						5: capacity 42 l/h
						R: clockwise rotation
L: counter-clockwise rotation						
						1: with one solenoid valve
						2: cartridge filter, pressure adjustment on front

Nozzle capacity at 4.3 cSt., 10 bar, 2800 min⁻¹

Technical Data

BFP 21 LE-S	3	5
Oil types	Standard fuel gas oil and fuel gas oil acc. to DIN V 51603-6 EL A Bio-10 (max. 10% FAME)	
Viscosity range (measured in suction inlet) ¹⁾	(1.3) 1.8 to 12.0 cSt. (mm ² /s)	
Filter area/mesh	11 cm ² /200 μm	
Pressure range ²⁾	7 to 20 bar	
Default setting	10 ±1 bar	
Max. pressure in suction inlet/return outlet	2 bar	
Speed	2400 to 3450 min ⁻¹	1400 to 3450 min ⁻¹
Max. starting torque	0.1 Nm	0.12 Nm
Ambient/transport temperature	-20 to +70° C	
Temperature of medium	0 to +70° C	
Coil power consumption	9 W	
Rated voltage (other voltages on request)	230 V, 50/60 Hz	
Coil enclosure	IP 40	
Shaft/neck	EN 225	

¹⁾ Special pumps for Kerosene.

²⁾ Max. 12 bar at 1.3 cSt., max. 15 bar at 1.8 cSt.

Nozzle capacity

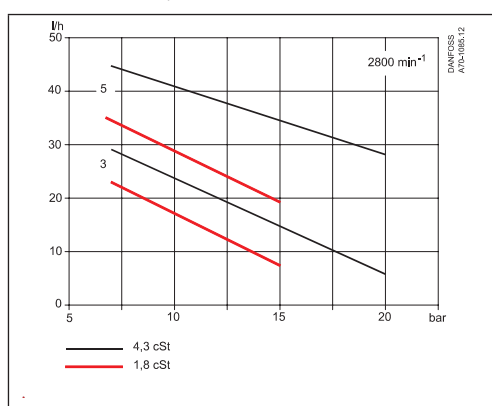

Operating torque

Power consumption

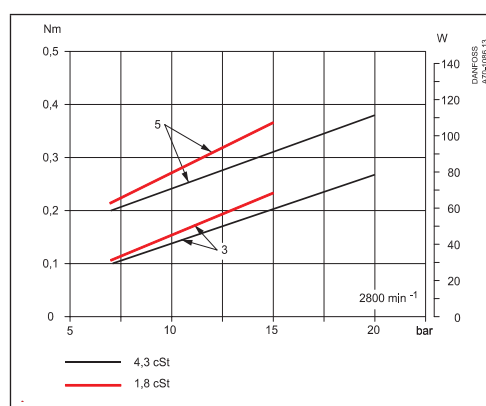

Connections

Example shows BFP 21 L3L LE-S

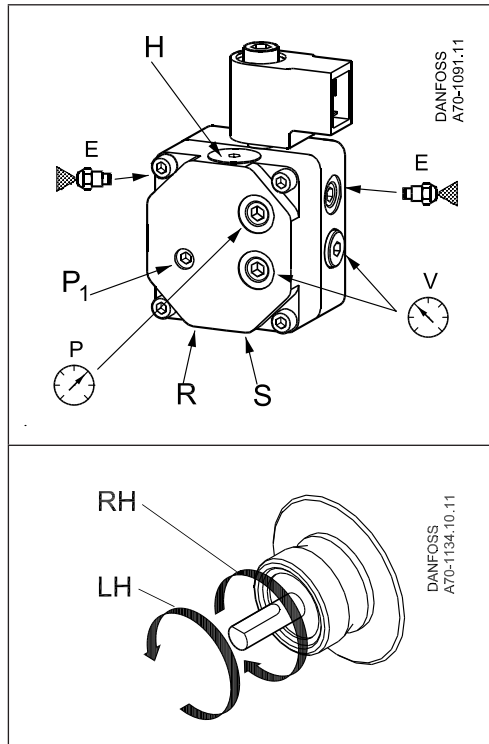

- P₁: Pressure adjustment
- S: Suction inlet G¹/₄
- R: Return outlet G¹/₄
- E: Nozzle outlet G¹/₈
- P: Pressure gauge port G¹/₈
- V: Vacuum gauge port G¹/₈
- H: Filter

Note! Shaft rotation, location of nozzle outlet and other connections are seen from shaft end.

- RH: R-rotation
- LH: L-rotation

Change-over and Filter Replacement

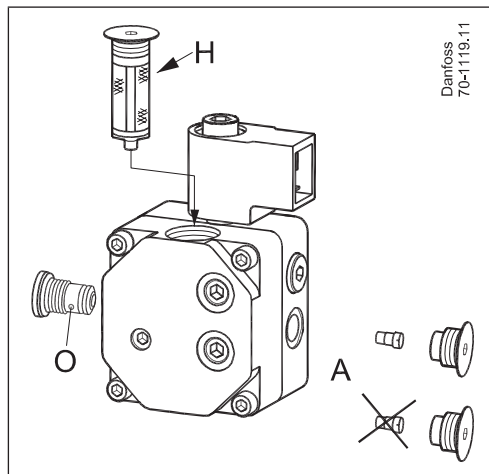

- H: Filter
- A: 2-pipe operation, with screw
1-pipe operation, without screw

Dimensions

