

Data sheet

CI-tronic™ Soft start motor controller

MCI 3, MCI 15, MCI 25, MCI 30 I-O, MCI 40-3D I-O and MCI 50-3 I-O



The MCI soft starters are designed for soft starting and stopping of 3 phase AC motors, thus reducing the inrush current and eliminating the damaging effects of high starting torque surges.

The digitally controlled soft starter features accurate settings and easy installation.

The controller has individually adjustable acceleration and deceleration times.

Thanks to the adjustable initial torque and the unique breakaway (kick start) function the soft starter can be optimized for almost any application.

The MCI soft starters are typically used on motor applications where a smooth start and/or stop is advantageous, such as conveyors, fans, pumps, compressors and high inertia loads. MCI soft starters are also obvious as replacement for star/delta starters.

Features

- Motor load max. 50 A
- Acceleration times adjustable:
 - 0 – 10 seconds, MCI 3, MCI 15 and MCI 25
 - 0 – 20 seconds, MCI 30 I-O
 - 0 – 30 seconds, MCI 40-3D I-O, MCI 50-3 I-O
- Deceleration times adjustable:
 - 0 – 10 seconds, MCI 3, MCI 15, and MCI 25
 - 0 – 20 seconds, MCI 30 I-O
 - 0 – 60 seconds, MCI 40-3D I-O, MCI 50-3 I-O
- Initial torque adjustable up to 85%
- Breakaway function (kick start)
- Universal control voltage:
24 – 480 V AC / DC
- Automatic detection of missing phases
- Automatic adaptation to 50/60 Hz
- Optional auxiliary contacts
- LED Status indication
- Unlimited start/stop operations per hour
- Built in varistor protection
- Compact modular design
- DIN rail mountable
- EN 60947-4-2
- CE and cULus (UL 508)
- EAC and LLC approved

Adjustments

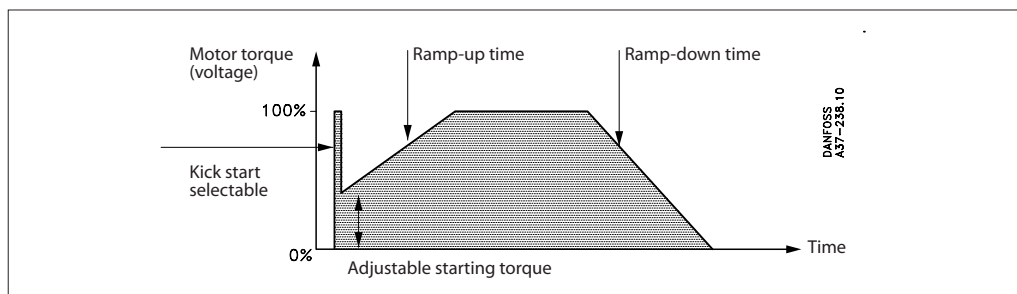

Selection guide

Type	Operational voltage	Motor current max.	Motor power max.	Module dimensions	Aux. contacts	Code no.
	[V AC]	[A]	[kW / HP]	[mm]		
MCI 15	208 – 240	15	4.0 / 5.5	45	–	037N0037
MCI 25	208 – 240	25 (30) ¹⁾	11 / 15 ¹⁾	90	I-O, bypass	037N0069
MCI 50-3 I-O	208 – 240	35 (50) ¹⁾	15 / 20 ¹⁾	180	I-O, bypass	037N0089
MCI 3	380 – 415	3	1.5 / 2	22.5	–	037N0074
MCI 3	440 – 480	3	1.5 / 2	22.5	–	037N0084
MCI 15	380 – 480	15	7.5 / 10	45	–	037N0039
MCI 25	380 – 480	25	11 / 15	90	–	037N0040
MCI 30 I-O	380 – 480	25 (30) ¹⁾	15 / 20 ¹⁾	90	I-O, bypass	037N0070
MCI 40-3D I-O	380 – 480	29 (43) ¹⁾	21 / 28 ¹⁾	90	I-O, bypass	037N0092
MCI 50-3 I-O	380 – 480	35 (50) ¹⁾	22 / 30 ¹⁾	180	I-O, bypass	037N0090
MCI 15	500 – 600	15	7.5 / 10	45	–	037N0041
MCI 25	500 – 600	25	15 / 20	90	–	037N0042

¹⁾ If used with bypass contactor

Technical data

Output Specification	MCI 3	MCI 15	MCI 25	MCI 30 I-O	MCI 40-3D I-O	MCI 50-3 I-O
Operational current max.	3 A	15 A	25 A	30 A (if bypassed during steady state)	43 A (if bypassed during steady state)	50 A (if bypassed during steady state)
	Motor size at:					
208 – 240 V AC	0.1 – 0.7 kW (0.18 – 1 HP)	0.1 – 4.0 kW (0.18 – 5.5 HP)	0.1 – 7.5 kW (0.18 – 10 HP)	0.1 – 11 kW (0.18 – 15 HP)	–	0.1 – 15 kW (0.18 – 20 HP)
380 – 480 V AC	0.1 – 1.5 kW (0.18 – 2 HP)	0.1 – 7.5 kW (0.18 – 10 HP)	0.1 – 11 kW (0.18 – 15 HP)	0.1 – 15 kW (0.18 – 20 HP)	0.1 – 21 kW (0.18 – 28 HP)	0.1 – 22 kW (0.18 – 30 HP)
500 – 600 V AC	0.1 – 2.2 kW (0.18 – 3 HP)	0.1 – 7.5 kW (0.18 – 10 HP)	0.1 – 15 kW (0.18 – 20 HP)	0.1 – 18.5 kW (0.18 – 25 HP)	–	0.1 – 30 kW (0.18 – 40 HP)
Leakage current max	5 mA					
Min. operational current	50 mA					
Overload relay trip class	Class 10					
Semiconductor protection Type 1 co-ordination Type 2 co-ordination I ² t (t = 10ms)	25 A gL/gG 72 A ² s	50 A gL/gG 1800 A ² s	80 A gL/gG 6300 A ² s	80 A gL/gG 6300 A ² s	80 A gL/gG 6300 A ² s	125 A gL/gG 25300 A ² s
Rating index:						
AC-53a Asynchronous motors	–	15A: AC-53a: 8-3: 100-3000	25A: AC-53a: 6-5: 100-480	25A: AC-53a: 6-5: 100-480	29A: AC-53a: 6-5: 100-120	35A: AC-53a: 6-6: 100-120
AC-53b Asynchronous motors with bypass	3A: AC-53b: 5-5: 10	–	–	30A: AC-53b: 5-5: 30	43A: AC-53b: 5-5: 30	50A: AC-53b: 6-6: 30
AC-58a Hermetic refrigeration compressors	–	15A: AC-58a: 6-6: 100-3000	25A: AC-58a: 6-6: 100-480	25A: AC-58a: 6-6: 100-480	–	–

Control Circuit Specifications

Control voltage range	24 – 480 V AC / DC					
Pick-Up voltage max.	20.4 V AC / DC					
Drop-out voltage min.	5 V AC / DC					
Max. control current for no operation	1 mA					
Control current / Power max.	15 mA / 2 VA					
Response time max.	70 ms					
Ramp-up time	adjust. from 0 – 10 seconds			0 – 20 seconds		0 – 30 seconds
Ramp-down time	adjust. from 0 – 10 seconds			0 – 20 seconds		0 – 60 seconds
Initial Torque	adjust. from 0 – 85% of nominal torque with optional kick start					
SCR Aux. contacts, opt. voltage/current max. (AC-14, AC-15)	24 – 480 V AC / 0.5 A					24 – 480 V AC / 1.0 A
Fuse max. I ² t (t = 10ms)	10 A gL/gG, I ² t max. 72 A ² s					
EMC immunity and emission	Meets requirements of EN 60947-4-2					

Insulation

Rated installation voltage, U _i	660 V AC
Rated impulse withstand voltage, U _{imp} V	4 k
Installation Category	III

Thermal specifications	MCI 3	MCI 15	MCI 25	MCI 30 I-O	MCI 40-3D I-O	MCI 50-3 I-O
Power dissipation ¹⁾ , continuous duty max.:	4 W	2 W/A	2 W/A	2 W/A	3 W/A	3 W/A
Power dissipation ¹⁾ , Intermittent duty max.:	4 W	2 W/A x duty cycle	2 W/A x duty cycle	2 W/A x duty cycle	3 W/A x duty cycle	3 W/A x duty cycle
Ambient temperature range	-5 °C – 40 °C					
Cooling method	Natural convection					
Mounting	Vertical +/- 30°					
Max. ambient temperature with limited rating	60 °C, see derating for high temperatures in chart page 7					
Storage temp. range	-20 °C – 80 °C					
Protection degree / pollution degree	IP20 / IP3					IP10 / IP3

Materials

Housing	Self extinguishing PPO UL94V1
Heatsink	Aluminum black anodized
Base	Electroplated steel

¹⁾ If used without a bypass contactor

Functional diagram

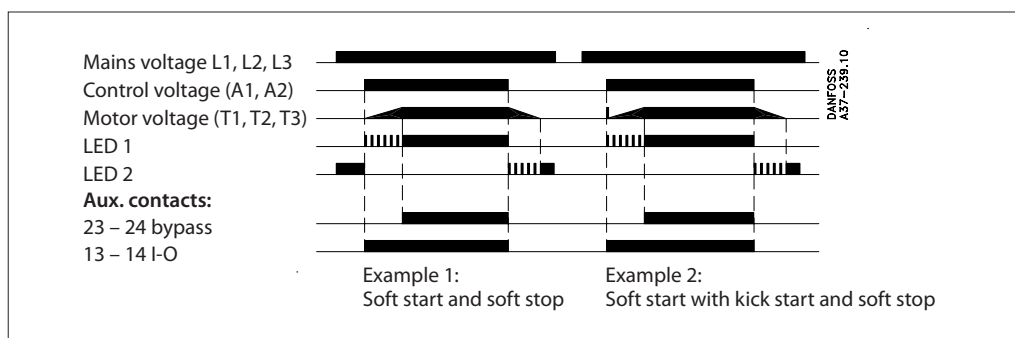

Functional description

Ramp up

During ramp-up the controller will gradually increase the voltage to the motor until it reaches full line voltage. The motor speed will depend on the actual load on the motor shaft. A motor with little or no load will reach full speed before the voltage has reached its maximum value. The actual ramp time is digitally calculated and will not be influenced by other settings, net frequency or load variations.

Initial torque

The initial torque is used to set the initial starting voltage. This way it is possible to adapt the controller to an application requiring a higher starting torque. In some cases on application with very high break-away torque the initial torque can be combined with a kick start function. The kick start is a period of 200 ms where the motor receives full voltage.

Soft stop

During ramp-down the controller will gradually reduce the voltage to the motor thus reducing the torque and current. As a consequence the motor speed will fade off. The soft stop feature is advantageous to avoid liquid hammering and cavitation on pumps, and to avoid goods tilting on conveyors.

Auxiliary contacts, optional

The auxiliary contacts are made possible by means of SCR technology and will only switch correctly on AC current.

I-O contact (13 – 14):

The contact will be closed as long as the controller receives a control voltage, see functional diagram.

Bypass contact (23 – 24):

The contact is intended for operating an external bypass contactor. The contact will close when the controller is in steady state operation, see functional diagram.

LED status indication

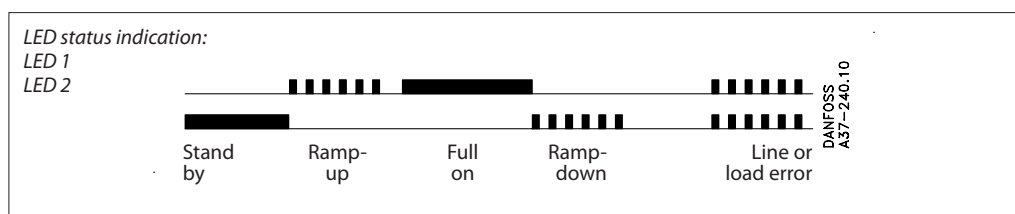

Wiring

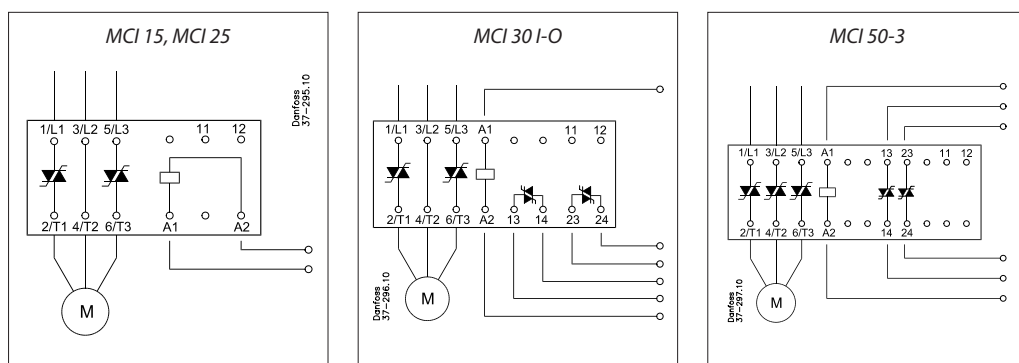

Overload and Short Circuit Protection

Overload and short circuit protection is easily achieved by installing a circuit breaker on the line side of the soft starter. Select the circuit breaker from the table according to motor full load current.

Be aware of the maximum prospective short circuit current breaking capacity. For further information please refer to the data sheet on the circuit breaker.

380 – 415 V AC

Circuit breaker Type	Motor full load current	Soft starter Type	Soft starter I ² t value	Max. prospective short-circuit current I _{cc} for co-ordination 2	Circuit breaker Code no.
	[A]		[A ² s]	[kA]	
CTI 25M	0.40 – 0.63	MCI 15	1800	100	047B3143
CTI 25M	0.63 – 1.0	MCI 15	1800	100	047B3144
CTI 25M	1.0 – 1.6	MCI 15	1800	100	047B3145
CTI 25M	1.6 – 2.5	MCI 15	1800	100	047B3146
CTI 25M	2.5 – 4.0	MCI 15	1800	100	047B3147
CTI 25M	4 – 6.3	MCI 15	1800	4	047B3148
CTI 25M	6.3 – 10	MCI 15	1800	1.5	047B3149
CTI 25M	10 – 16	MCI 15	1800	2.5 ¹⁾	047B3150
CTI 25M	14.5 – 20	MCI 25/30 I-O	6300	1.8	047B3151
CTI 25M	18 – 25	MCI 25/30 I-O	6300	1.5	047B3152
CTI 45MB	23 – 32	MCI 50 I-O	25300	6	047B3164
CTI 45MB	32 – 45	MCI 50 I-O	25300	4	047B3165

¹⁾ Type 2 co-ordination can only be achieved with MCI 25

Operation at high temperatures

If soft starter is used without external bypass contactor:

Ambient temperature	Continuous current					
	MCI 3	MCI 15	MCI 25	MCI 30 I-O	MCI 40-3D I-O	MCI 50-3 I-O
	[A]	[A]	[A]	[A]	[A]	[A]
40 °C	3	15	25	25	29	35
50 °C	2.5 ¹⁾	12.5	20	20	23	30
60 °C	2.0 ¹⁾	10	17	17	20	25

¹⁾ Minimum 10 mm side clearance between products

Ambient temperature	Duty-cycle rating (15 min. max. on-time)				
	MCI 15	MCI 25	MCI 30 I-O	MCI 40-3D I-O	MCI 50-3 I-O
	[A]	[A]	[A]	[A]	[A]
40 °C	15 (100% duty cycle)	25 (100% duty cycle)	25 (100% duty cycle)	43 (65% duty cycle)	50 (65% duty cycle)
50 °C	15 (80% duty cycle)	25 (80% duty cycle)	25 (80% duty cycle)	43 (50% duty cycle)	50 (55% duty cycle)
60 °C	15 (65% duty-cycle)	25 (65% duty-cycle)	25 (65% duty-cycle)	43 (40% duty-cycle)	50 (45% duty-cycle)

If soft starter is used with external bypass contactor

Ambient temperature	Continuous current				
	MCI 25	MCI 25	MCI 30 I-O	MCI 40-3D I-O	MCI 50-3 I-O
	[A]	[A]	[A]	[A]	[A]
40 °C	15	25	30	43	50
50 °C	15	25	30	43	50
60 °C	15	25	30	43	50

Over heat protection

If required the controller can be protected against overheating by inserting a thermostat in the slot on the right-hand side of the controller.

Order: UP 62 thermostat **037N0050**

Depending on the application the thermostat can be connected in series with the control circuit of the main contactor. When the temperature of the heat sink exceeds 90 °C the main contactor will be switched OFF. A manual reset is necessary to restart this circuit.

For wiring connections see application examples page 8.

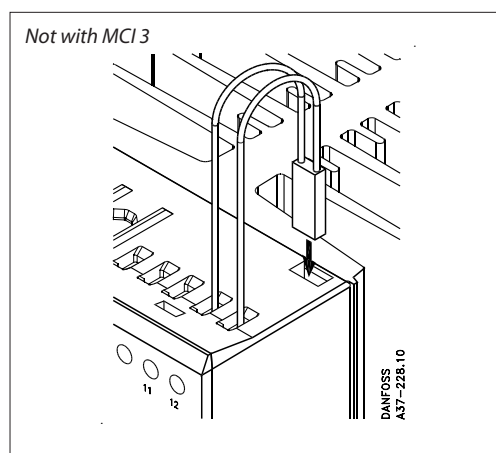

Mounting Instructions

The controller is designed for vertical mounting. If the controller is mounted horizontally the load current must be reduced by 50%.

The controller needs no side clearance.

Clearance between two vertical mounted controller must be minimum 80 mm (3.15").

Clearance between controller and top and bottom walls must be minimum 30 mm (1.2").

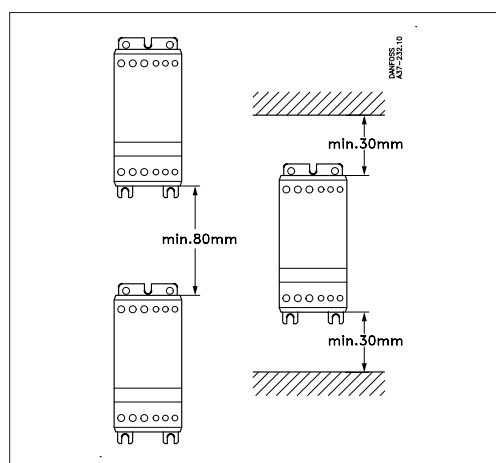

Application examples

Overheat protection

Example 1

The thermostat can be connected in series with the control input of the soft starter. When the temperature of the heat sink exceeds 90 °C the soft starter will be switched OFF.

NOTE:

when the temperature has dropped approx. 30 °C the controller will automatically be switched ON again. This is not acceptable in some applications.

Example 2

The thermostat is connected in series with the control circuit of the main contactor. When the temp. of the heat sink exceeds 90 °C the main contactor will be switched OFF. This circuit requires manual reset to restart the motor.

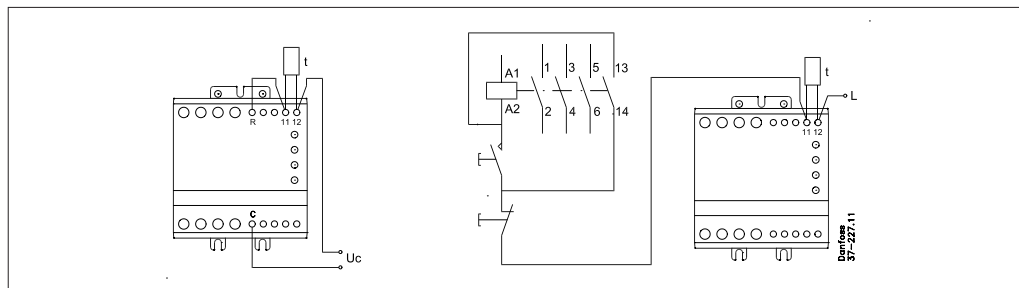

Line Controlled Soft start

When the contactor C1 is switched to the ON-State, the soft starter will start the motor, according to the settings of the Ramp-up time and Initial torque adjustments.

When the contactor C1 is switched to the OFF-State the motor will be switched off instantaneously.

In this application the contactor will have no load during making operation. The contactor will carry and break the nominal motor current.

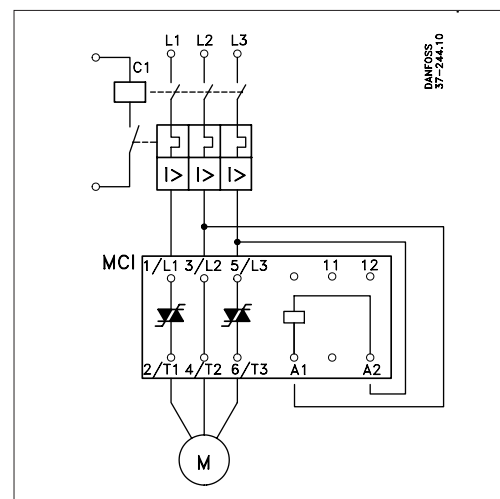

Application examples
(Cont.)

Input controlled soft start

When the control voltage is applied to A1 – A2, the MCI soft starter will start the motor, according to the settings of the Ramp-up time and Initial torque adjustments.

When the control voltage is switched OFF, the motor will be soft stopped according to the settings of the Ramp-down time adjustment.

To switch off instantaneously set the Ramp-down time to 0.

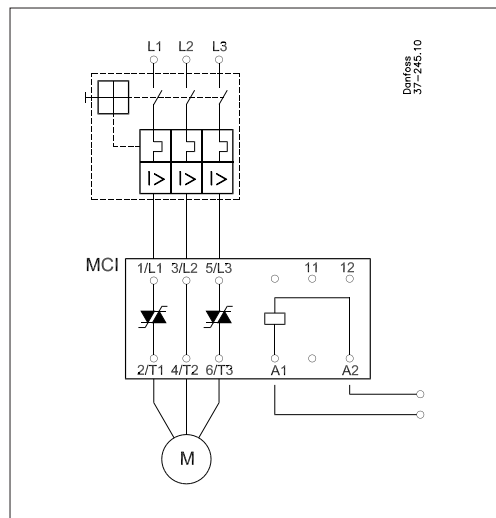

Combined reversing contactor and soft starter

Soft Start & Soft Stop

A soft – reversing of a motor can easily be achieved by connecting a reversing contactor to the soft starter.

The reversing contactor, type RCI, will determine the direction of rotation, forward or reverse and the soft starter, type MCI, will perform soft-starting and soft-stopping of the motor.

Soft Start only

If soft-stop is not required the application can be simplified by connecting the control circuit, of the soft starter, to the main terminals as shown under Line controlled Soft-Start (see example on page 8).

A delay of approx. 0.5 sec. between forward and reverse control signal must be allowed to avoid influence from the voltage generated by the motor during turn-off.

Instead of the electronic reversing contactor, type RCI, an electromechanical reversing contactor can be applied. Due to the soft starter the reversing contactor will not be exposed to high inrush currents. As a result a longer life time of the electromechanical contactor can be expected.

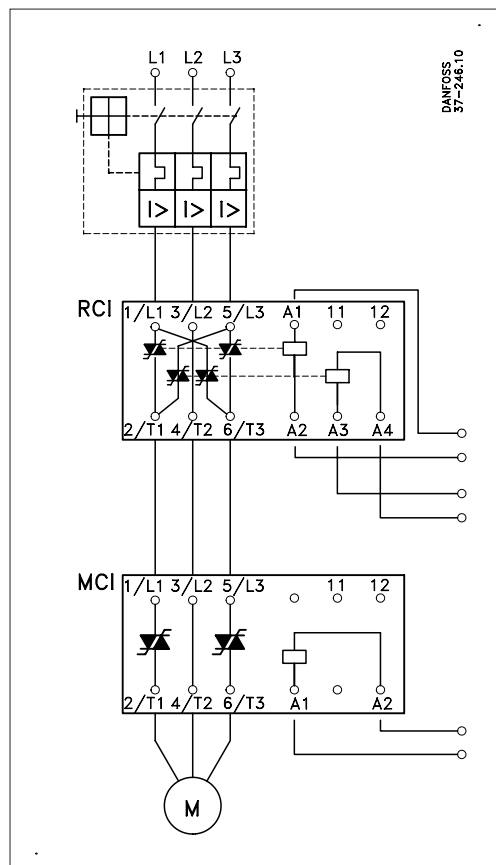

Application examples
(Cont.)

MCI with bypass contactor

If the MCI soft starter is bypassed during steady state operation there is no heat dissipation.

A bypassed MCI can be loaded according to tabel page 7: "Operating at high temperatures".

By means of the integrated auxiliary contact the bypass function is easily achieved. See wiring diagram below and "Functional diagram" page 5.

As the contactor always switches in after end of ramp up time it can be selected on the basis of the thermal current (AC-1).

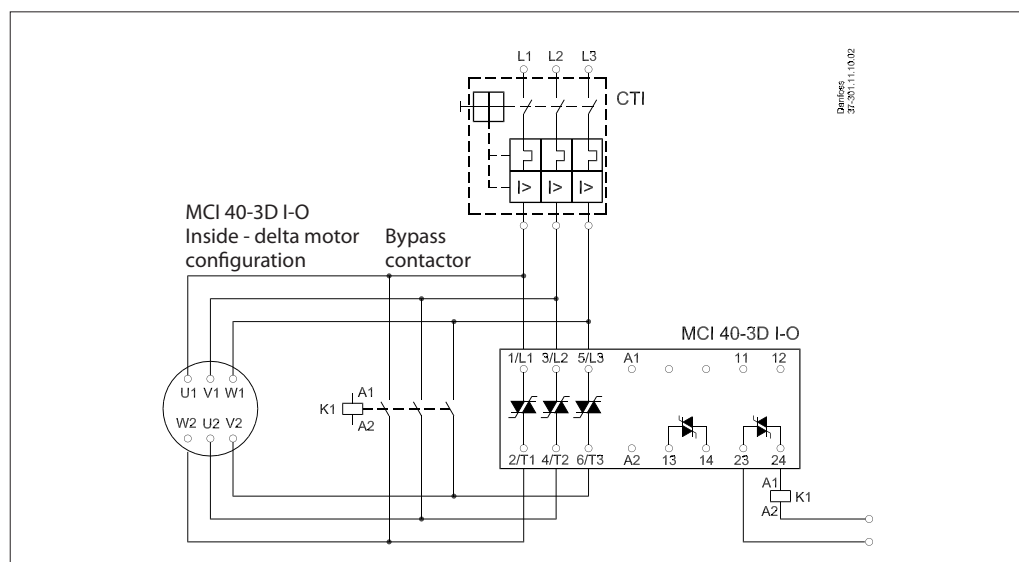
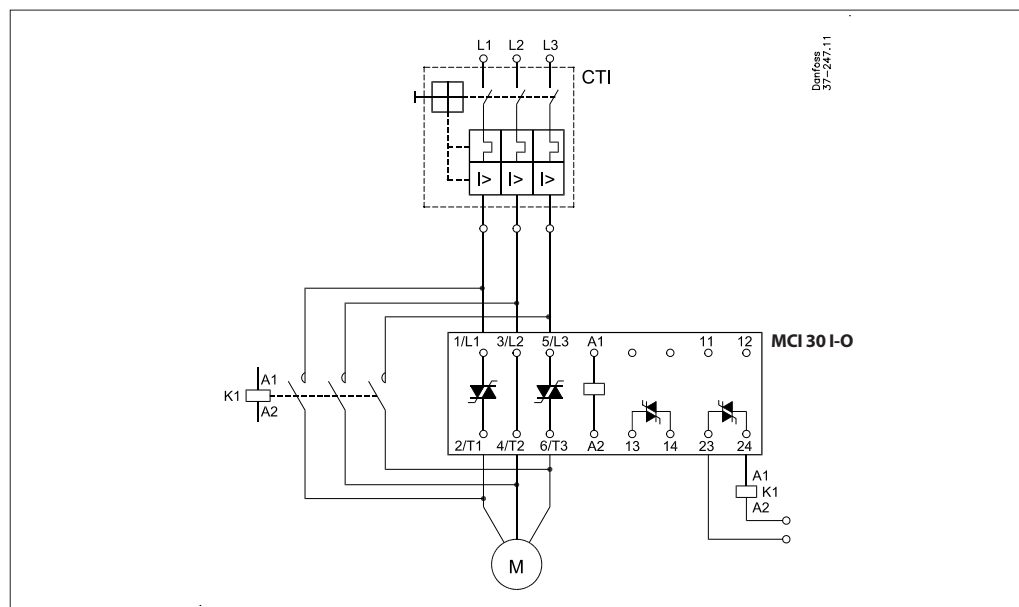

Dimensions mm (inch)

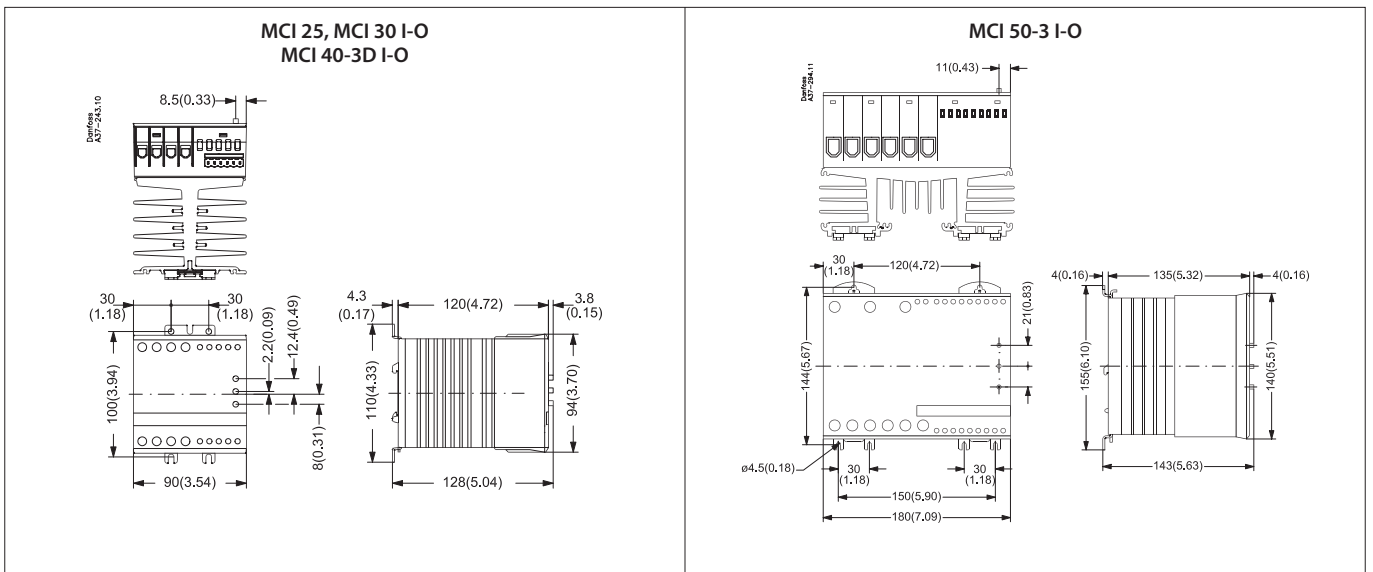
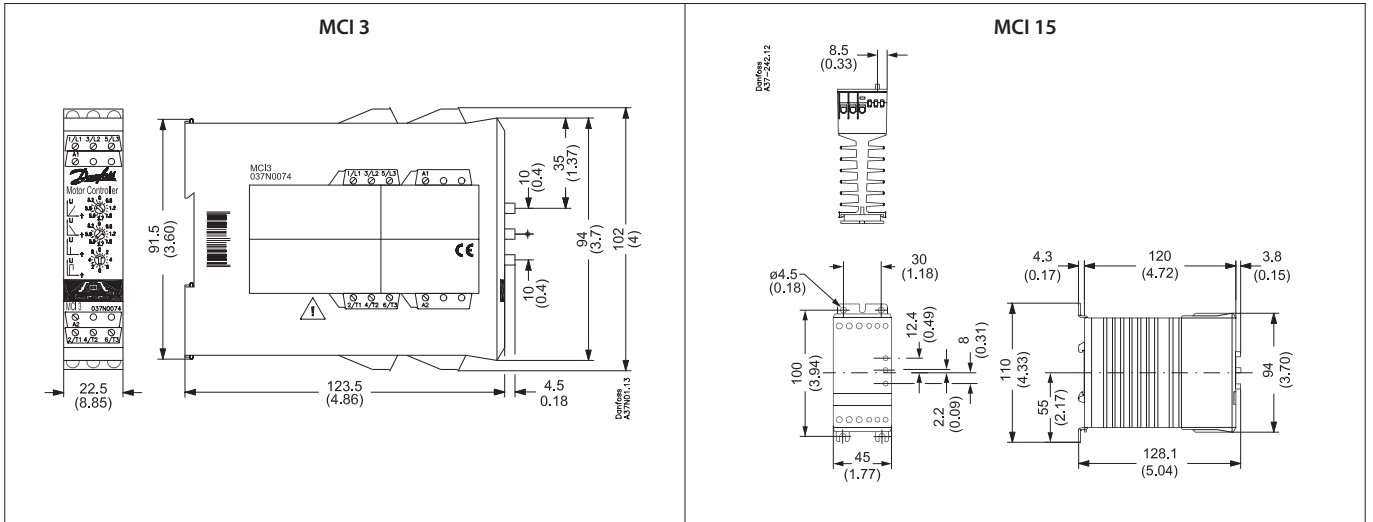

Danfoss can accept no responsibility for possible errors in catalogues, brochures and other printed material. Danfoss reserves the right to alter its products without notice. This also applies to products already on order provided that such alterations can be made without subsequent changes being necessary in specifications already agreed. All trademarks in this material are property of the respective companies. Danfoss and the Danfoss logotype are trademarks of Danfoss A/S. All rights reserved.