

avrorarm.ru
+7 (495) 956-62-18

ENGINEERING
TOMORROW

Danfoss

Instruction

APP pumps

APP 11 / APP 13 / APP 16 /
APP 17 / APP 19 / APP 22



Table of Contents	1.	Identification	2
	2.	System design	3
	2.1	Open-ended systems with direct water supply	3
	2.2	Preferred RO system design and P&ID	4
	2.3	Reversible pumps	4
	2.4	General comments on	4
	3.	Building up the pump unit	5
	3.1	Mounting	5
	3.2	Direction of rotation	6
	3.3	Orientation	6
	3.4	Protection against too high outlet pressure	7
	3.5	Connections	7
	4.	Initial start-up	9
	5.	Operation	10
	5.1	Temperature	10
	5.2	Pressure	10
	5.3	Dry running	10
	5.4	Disconnection	10
	5.5	Storage	10
	5.5.1	Recommended procedure	10
	6.	Service	11
	6.1	Warranty	11
	6.2	Maintenance	11
	6.3	Repair	11

1. Identification

PUMP		 MADE IN DENMARK
Type	APP 16	
Code no.	180BXXXX	
Serial no.	XXXXXXXX-XXX	Danfoss A/S, 6430 Nordborg, Denmark

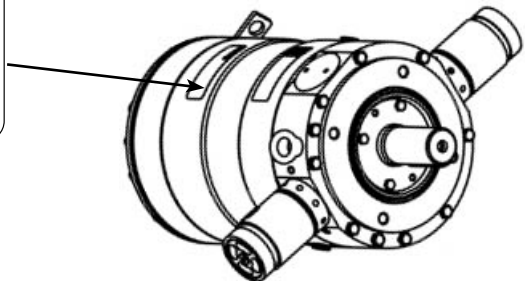

2. System design

The design of the system must ensure that self-emptying of the pump during standstill is avoided.

The inlet pressure of the pump must never exceed the outlet pressure. This may typically occur in boosted or open-ended systems with direct water supply.

2.1 Open-ended systems with direct water supply

The pump is supplied with water direct from a feed pump.

In order to eliminate the risk of cavitation, a positive inlet pressure of at least 2 barg (29 psig) is always to be maintained, but it must not exceed 5 barg (72.5 psig) continuously.

1. Place the filter (1) in the water supply line in front of the pump.
2. Place a monitoring pressure switch (3) between filter and pump inlet - set at min. 2 barg (29 psig) inlet pressure. The monitoring pressure switch must stop the pump at pressures lower than 2 barg (29 psi g) inlet pressure.
3. Install a low pressure safety valve or a low pressure relief valve (4) in order to avoid system or pump damage in case the pump stops momentarily (high-pressure peaks) or starts spinning backwards.

Note: If a non return valve (2) is mounted in the inlet line, a low-pressure relief valve is also required between non return valve and pump as protection against high-pressure peaks.

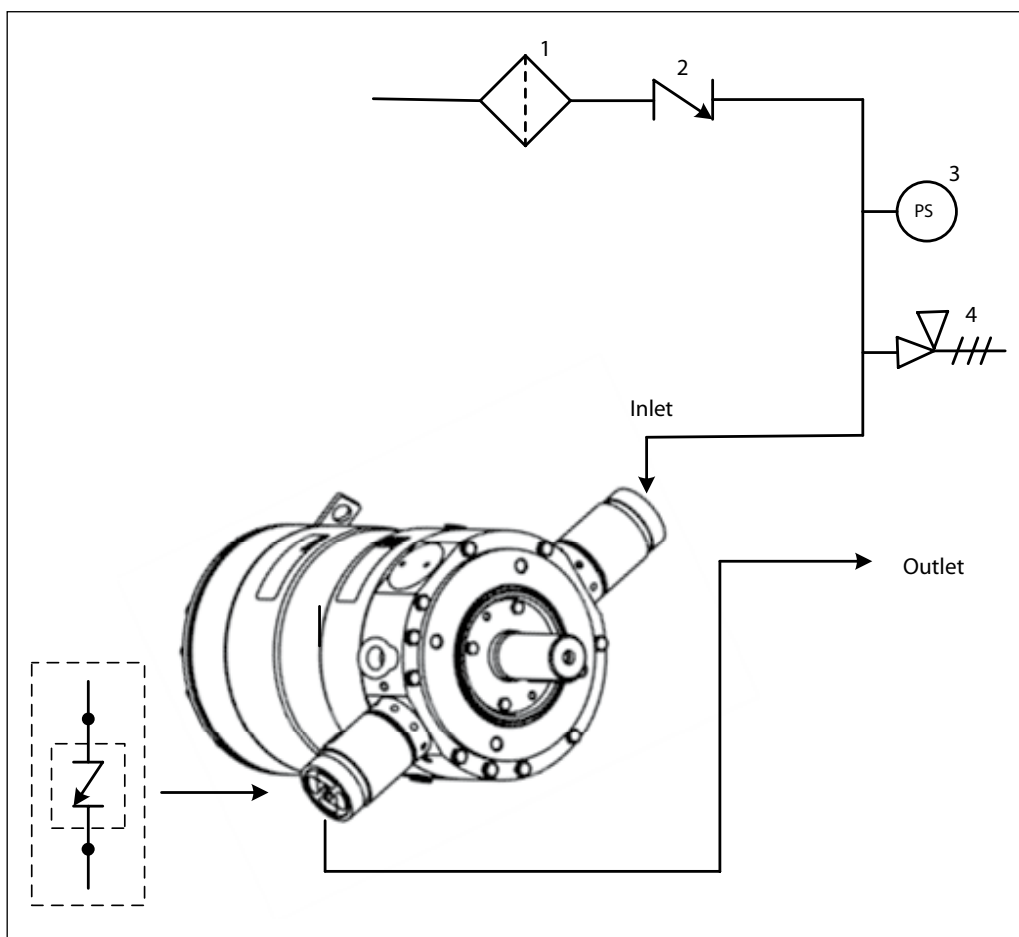

2.2 Preferred RO system design and P&ID

1. Dimension the inlet line to obtain minimum pressure loss (large flow, minimum pipe length, minimum number of bends/connections, and fittings with small pressure losses).
2. Place an inlet filter (1) in front of the APP pump (2). Please consult the Danfoss filter data sheet for guidance (521B1009) on how to select the right filter. Thoroughly clean pipes and flush system prior to start-up.
3. Place a monitoring pressure switch (3) set at min. inlet pressure between filter and pump inlet. The monitoring switch must stop the pump at pressures lower than minimum pressure.
4. Use flexible hoses (4) to minimize vibrations and noise.
5. In order to eliminate the risk of damage and cavitation, a positive pressure at the inlet (5) is always to be maintained at min. inlet pressure and max. inlet pressure. Recommend to install safety valve or a

pressure relief valve (9) in order to avoid high-pressure peaks in case the pump stops momentarily or starts spinning backwards.

6. For easy system bleeding and flushing, a bypass non-return valve (6) is integrated in the APP pump.
7. A non-return valve (7) in outlet can be installed in order to avoid backspin of the pump. The volume of water in the membrane vessel works as an accumulator and will send flow backwards in case of the pump stops momentarily.
8. A safety valve or a pressure relief valve (8) can be installed in order to avoid system damage as the Danfoss APP pump creates pressure and flow immediately after start-up, regardless of any counter pressure.

Note: If a non-return valve is mounted in the inlet line, a low-pressure relief valve is also required between non return valve and pump as protection against high-pressure peaks.

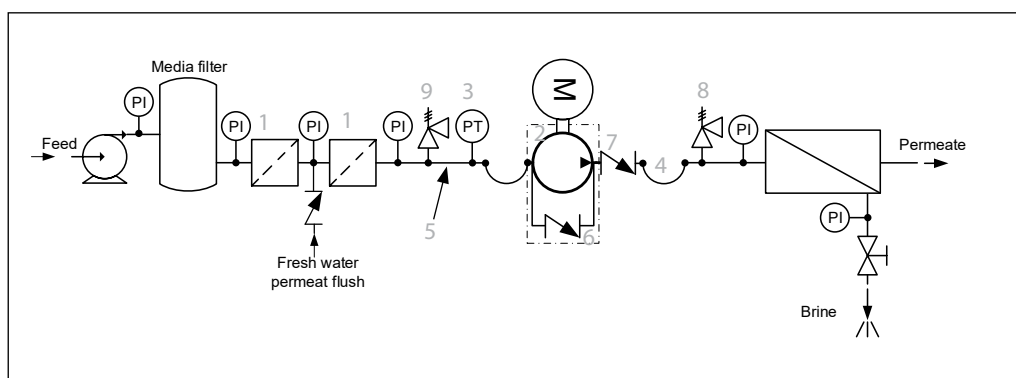

2.3 Reversible pumps

If exposed to high pressure in the outlet while the electric motor is not energized, the pump will start spinning backwards. This will not harm the pump as long as the pressure in the inlet does not exceed the max. pressure peak of 10 barg (145 psig).

If a non-return valve is mounted in the inlet line, a low-pressure relief valve is also required as protection against high-pressure pulses and high pressure in general.

Alternatively a high-pressure check valve can be mounted in the pump discharge line to prevent the pump from reversing.

The dotted setup ensures that the inlet pressure does not exceed 10 barg (145 psig), when a non-return valve is mounted in the inlet.

Attention: In order to avoid the risk of cavitation, the inlet pressure at the pump must be min. 2 barg (29 psig).

The inlet line connection must be properly tightened, as possible entrance of air will cause cavitation.

2.4 General comments on

Filtration

A good filtration is vital to ensure a long and trouble free life of the pump.

As water has very low viscosity, the APP pumps have been designed with very narrow clearance in order to control internal leakage rates and improve component performance. Therefore it is important that the inlet water is filtered properly to minimize the wear of the pump.

The main filter must have a filtration efficiency of 99.98% at 10 μm . We recommend to use precision depth filter cartridges rated 10 μm abs. $\beta_{10} \geq 5000$ (equivalent to a filtration efficiency of 99.98%). Bag filters and string wounded filter cartridges typically have only 50% filtration efficiency. This means that for each 100,000 particles reaching the filter, 50,000 particles pass through it compared to only 20 particles in a filter with an efficiency of 99.98%.

For more information on the importance of proper filtration, please consult our data sheet "Filtration" (521B1009), which also will provide you with an explanation of filtration definitions and a guidance on how to select the right filter.

Monitoring

It is recommended to continuously monitor the following conditions:

- filter clogging
- pressure (inlet- and outlet side of the pump)

3. Building up the pump unit

3.1 Mounting

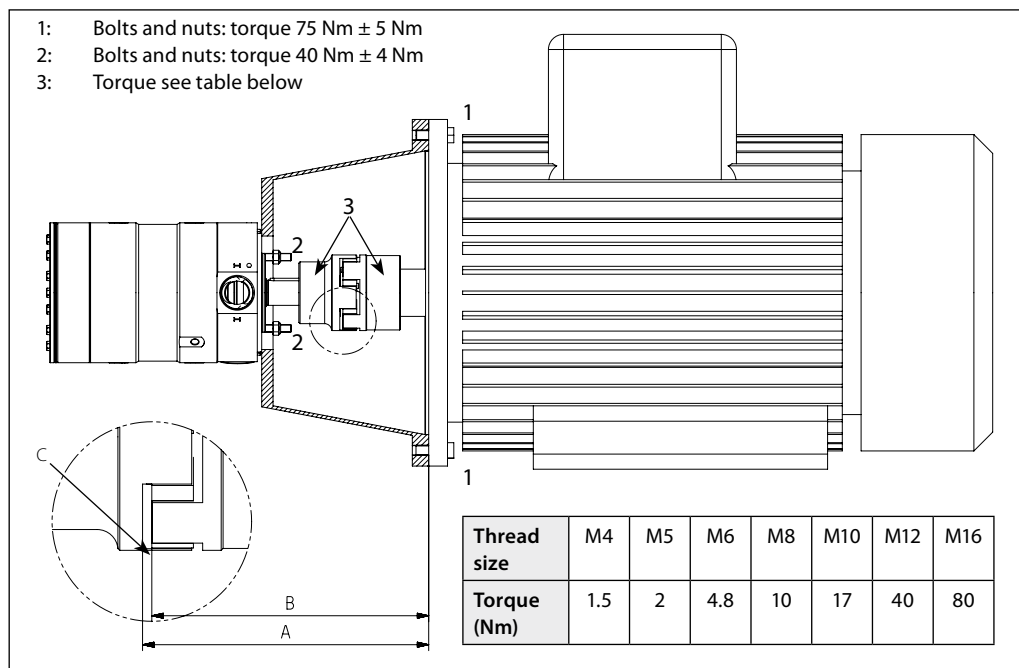
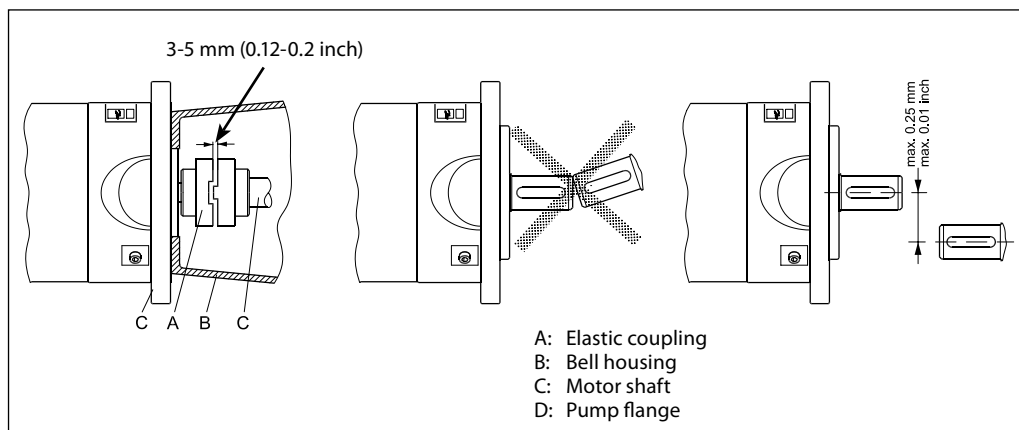

1. Mount the coupling flush or maximum 1 mm offset from the pump shaft end. Ensure an air gap between coupling parts of 3-5 mm (0.12-0.2 inch).
2. Mount the bell housing on pump. Secure nuts with the right torque.
3. Measure the longest distance "A" from top of bell housing to the button of coupling gear.
4. Mount the coupling on motor shaft. Ensure the coupling and motor flange are not in contact with each other.
5. Measure from motor flange to the top of the coupling. That measurement "B" shall be 3-5 mm (0.12 - 0.2 inch) shorter than the measurement "A".
6. Adjust respectively, verify the measurement, and secure both couplings with the right torques on the locking screws (see coupling operation & mounting instruction).
7. Mount the elastic gear ring and mount the bell housing/pump on the motor. After mounting it must be possible to move the elastic gear ring 3-5 mm (0.12 - 0.2 inch) axial "C". The check can be done through the inspection hole of bell housing. Secure flange bolts with the right torque.

If alternative mounting is desired, please contact Danfoss High Pressure Pumps.

Choose proper tolerances to ensure an easy mounting of the elastic coupling without use of tools.

Please take care to observe the recommended length tolerances of the chosen coupling, as an axial force on the pump will damage the pump.

3.2 Direction of rotation

Is indicated by means of an arrow on the pump label.

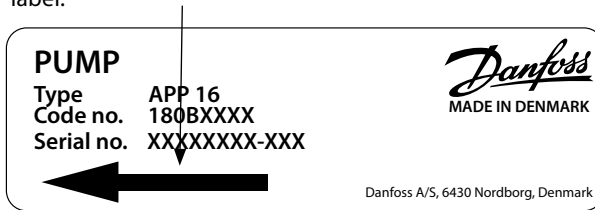

3.3 Orientation

The pump can be mounted/orientated in any horizontal direction with the inlet and the outlet pointing upwards, downwards or to either side.

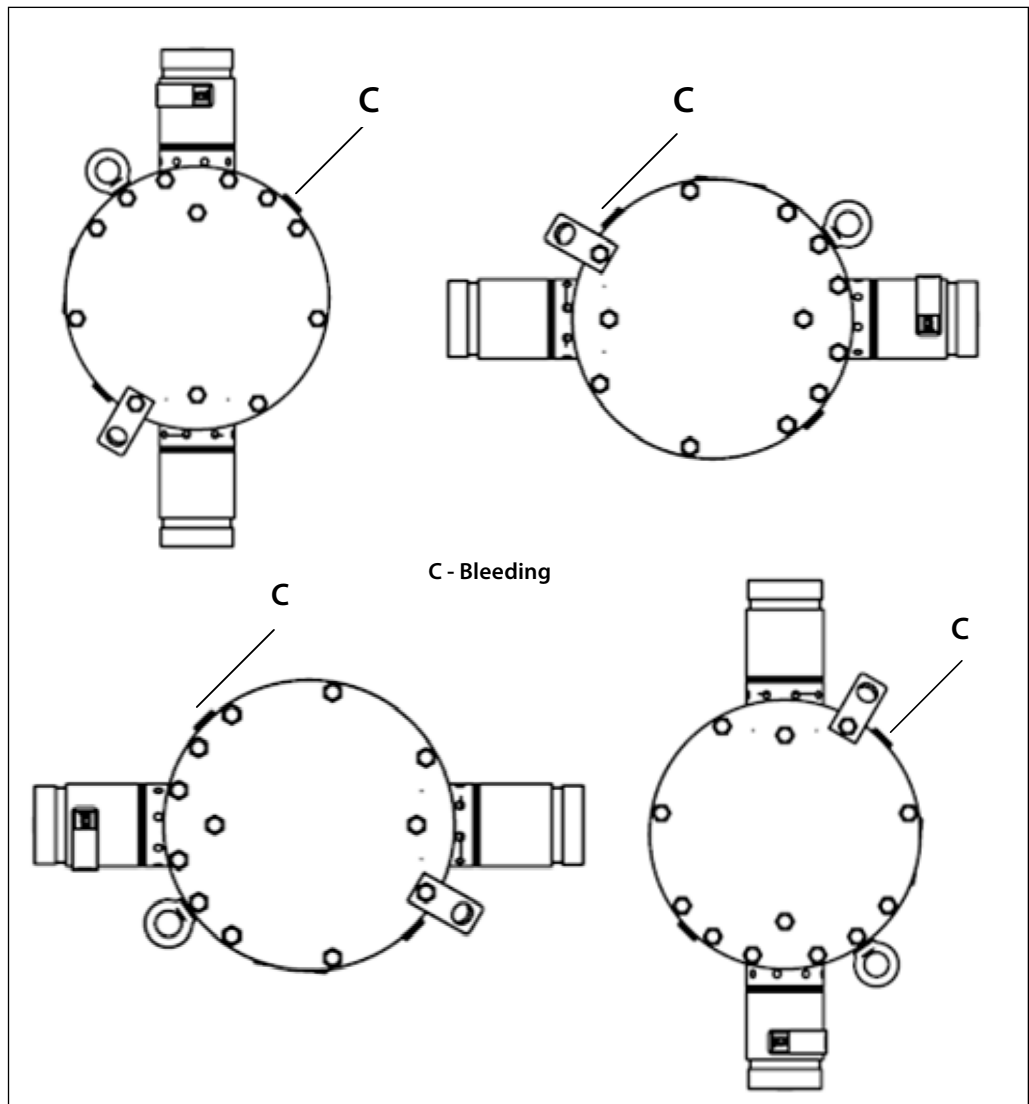

3.4 Protection against too high outlet pressure

The pump should be protected against too high outlet pressure by means of a safety valve or a pressure relief valve. The valve should be placed as close to the pump as possible. The opening characteristics of the valve must not result in peak pressures higher than 80 barg (1160 psig).

Both the inlet and outlet lines must be flexible soft hoses.

The valve outlet must not be connected directly to the pump suction line. It must be connected directly to the drain.

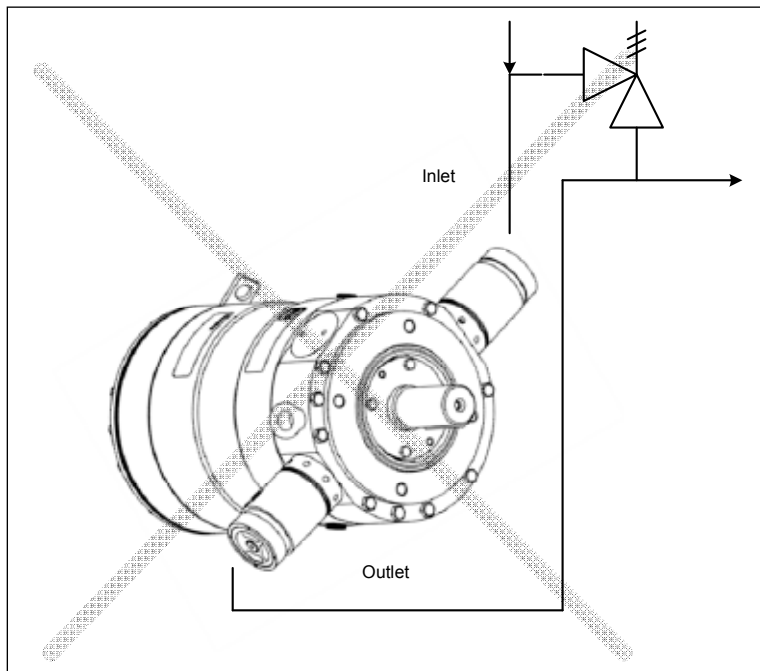
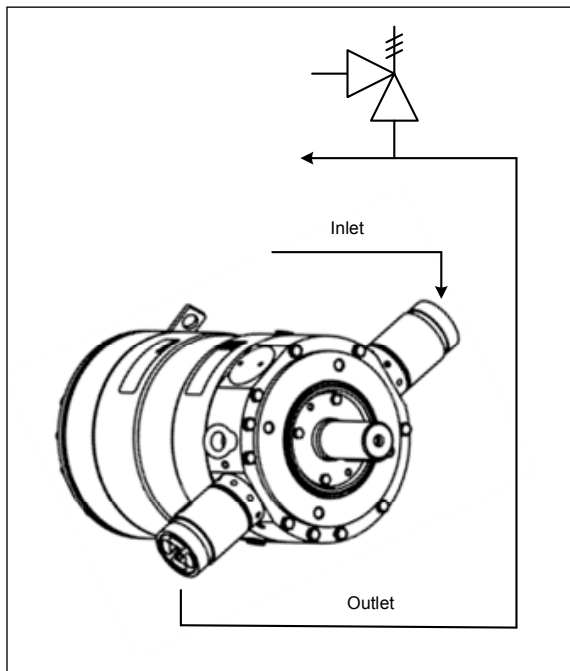

3.5 Connections

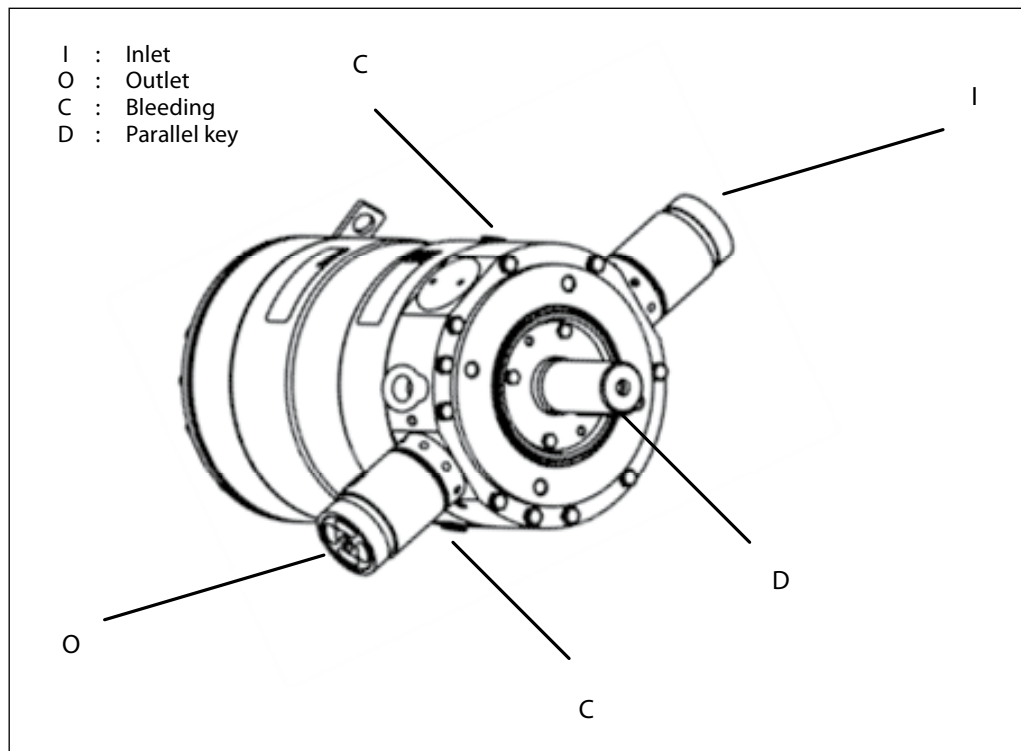

APP 11 - APP 13

Description		APP 11 - APP 13
Parallel key, DIN 6885	mm	10 × 8 × 45
	inch	0.39 × 0.31 × 1.77
Bleeding	G ¼", Hexagon AF = 6 mm	
Inlet port	M42 x 1.5; depth 17 mm	
Outlet port	M42 x 1.5; depth 17 mm	
Pump mounting flange	125 B 4	

Accessories	Type	Code no.
2" inlet hose kit 2 m / 79"	2" Victaulic	180Z0298
2" inlet Vic. Super Duplex	2" Victaulic	180Z0166
Non-return valve (outlet) Super Duplex	1,5" Victaulic (OD 48.3 mm)	180H0053

For more details on the accessories, please contact Danfoss High Pressure Pumps.

APP 16 – APP 22

Description		APP 16 – APP 22
Parallel key, DIN 6885	mm	12 × 8 × 70
	In	0.47 × 0.31 × 2.76
Bleeding	G ¼", Hexagon AF = 6 mm	
Inlet port	M52 x 1.5; depth 21 mm	
Outlet port	M52 x 1.5; depth 21 mm	
Pump mounting flange	125 B 4	

Accessories	Type	Code no.
2" inlet hose kit 2 m/79"	2" Victaulic	180Z0298
2" inlet Vic. Super Duplex	2" Victaulic	180Z0165
Non-return valve (outlet) Super Duplex	2" Victaulic (OD 63 mm)	180H0256

For more details on the accessories, please contact Danfoss High Pressure Pumps.

4. Initial start-up

1. Flush inlet line before connecting the pump, to remove possible impurities from pipes, hoses etc.
2. Connect pump inlet to inlet line and flush the pump for 5 min. by means of the internal flushing valve, to remove possible impurities from pipes, hoses etc.
3. Loosen top bleeding plug "C" (see item 3.3) using an allen key (only plugs with internal hexagan sockets). Retighten the plug, when water appears from the bleeding plug.
4. Make sure that the direction of rotation of the electric motor corresponds to the direction of rotation of the pump (see label on pump).
5. Now the pump is ready for start-up.

Warning:
Make sure that the direction of rotation of the electric motor corresponds to the direction of rotation of the pump (see label on pump). Otherwise the pump will be damaged if a check valve is placed between pump and feed pump.

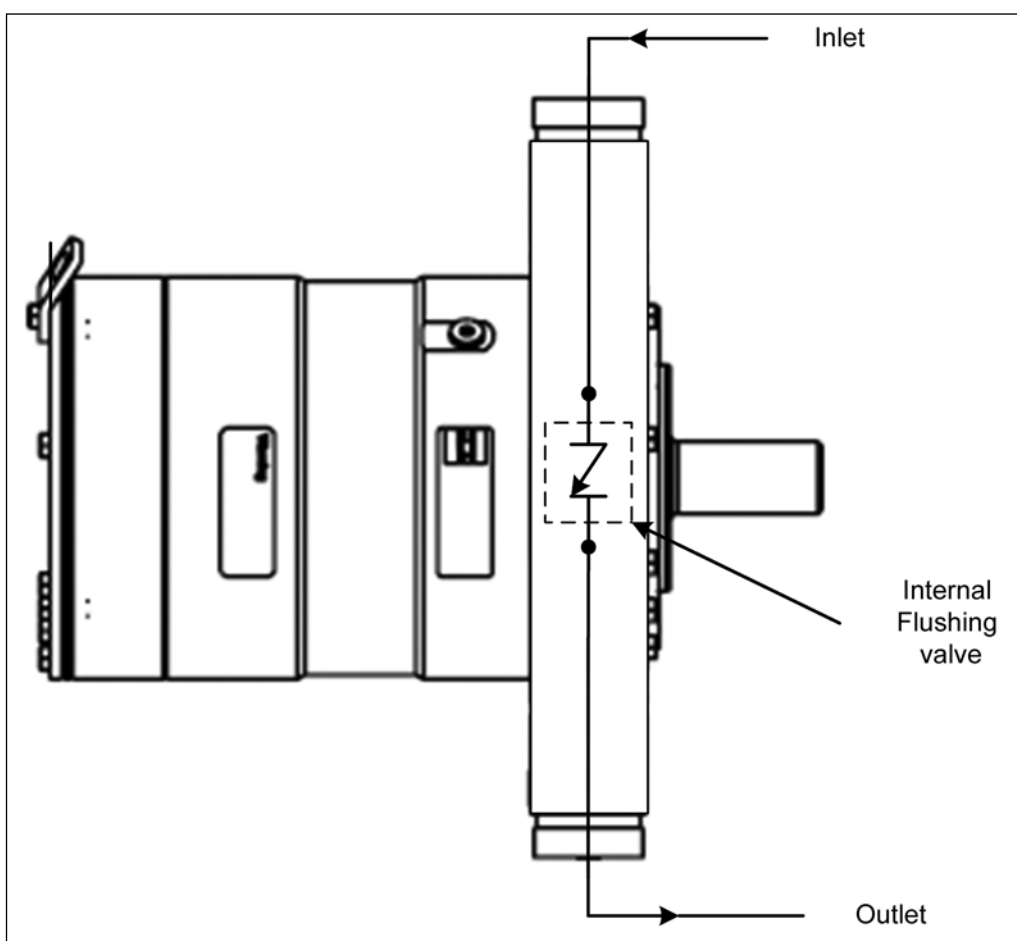

5. Operation

5.1 Temperature

Fluid temperature: Min. +2°C to max. +50°C (Min. +35.6°F to max. +122°F)
Ambient temperature: Min. +2°C to max. +50°C (Min. +35.6°F to max. +122°F)

The chart below illustrates the corrosive resistance of different types of stainless steel related to NaCl concentration and temperature.

The APP water pump is made of Duplex and Super Duplex. If the water pump is operated above the Super Duplex line, always flush water pump with fresh water at operation stop in order to minimise the risk of crevice corrosion.

In case of lower operating temperatures, please contact the Danfoss High Pressure Pumps.

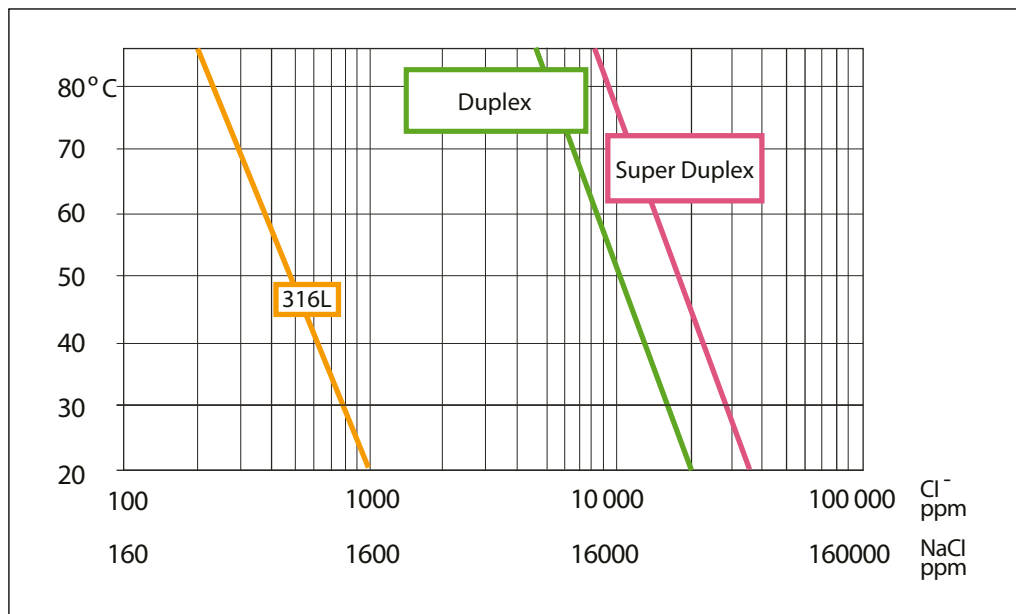

5.2 Pressure

The inlet pressure for APP 11-13 and APP 16-22 must be min. 2 barg (29 psig) and max. 5 barg (72.5 psig).

At lower pressures the pump will cavitate, resulting in damage of the pump.

Max. inlet pressure peak (e.g. in case the pump stops momentarily) up to 10 barg (145 psig) are acceptable.

Max. pressure on the pump's outlet line should be limited at 80 barg (1160 psig) continuously. **NB: The pump unit should include a pressure gauge on the high-pressure side.**

5.3 Dry running

When running, the pump must always be connected to the water supply in order to avoid damage if it should run dry.

5.4 Disconnection

If the inlet line is disconnected from the water supply, the pump will be emptied of water through the disconnected inlet line. When starting up again, follow the bleeding procedure described under section 4: Initial start up.

5.5 Storage

Storage temperature: Min. -40°C to max. +70°C (Min. -40°F to max. +158°F)

When preparing the pump for long-term storage or for temperatures below the freezing point, flush the pump with an anti-freeze medium type monopropylene glycol to prevent internal corrosion or frost in the pump.

For further information on anti-freeze media, please contact Danfoss High Pressure Pumps.

5.5.1 Recommended procedure

1. Disconnect the water supply to the pump.
2. Through the lower bleeding plug, empty the pump housing of water and close it again.
3. Connect the pump to a tank containing anti-freeze additive. Connect a hose to the inlet port of the pump and via another hose return the flow from the outlet port to the tank with anti-freeze additives.
4. Quickly start and stop the pump. **Make sure that the pump does not run dry.** The pump is now protected against internal corrosion and frost.

Storage:

Storage of pump that have been in operation:
For shorter periods of storage flush the pump with permeate rotating the pump for 10 sec., empty permeate and store.

For long term storage (more than 2 months) Danfoss recommends servicing the product and clean any biological growth of the surfaces. Store the pump dry without water inside.

6. Service**6.1 Warranty**

Danfoss APP pumps are designed for long operation, low maintenance and reduced lifecycle costs.

Provided that the pump has been running according to the Danfoss specifications, Danfoss guarantees 8,000 hours service-free operation, however, max 18 months from date of production.

If Danfoss recommendations concerning system-design are not followed, it will strongly influence the life of the APP pumps.

6.2 Maintenance

After 8,000 hours of operation **it is strongly recommended** to inspect the pump and change any worn parts, e.g. pistons and shaft seal. This is done in order to prevent a potential breakdown of the pump. If the parts are not replaced, more frequent inspection is recommended according to our guidelines.

Stand still

The APP pumps are made of Duplex/Super Duplex materials with excellent corrosion properties. It is however, always recommended to flush the pump with freshwater when the system is shut down.

When stopping the pump for more than 1 day flush the pump with permeate by rotating the pump for 10 sec. Flushing through the flushing valve of the pump without rotating the pump is not enough for cleaning the inside of the pump. The pump can be flushed with biocide like the membranes. The biocide must be compatible with the materials used in our pump (materials can be found in the parts list in the Operating guide).

6.3 Repair

In case of irregular function of the APP, please contact Danfoss High Pressure Pumps.

avroara-arm.ru
+7 (495) 956-62-18

ENGINEERING
TOMORROW



Danfoss can accept no responsibility for possible errors in catalogues, brochures and other printed material. Danfoss reserves the right to alter its products without notice. This also applies to products already on order provided that such alterations can be made without subsequential changes being necessary in specifications already agreed. All trademarks in this material are property of the respective companies. Danfoss and the Danfoss logotype are trademarks of Danfoss A/S. All rights reserved.
