

Data sheet

## Thermostatic expansion valve Type TU and TC



The thermostatic expansion valves TUA/TUAE, TCAE with exchangeable orifice, TUB/TUBE/TCBE with fixed orifice and TUC/TUCE/TCCE with fixed orifice and fixed superheat setting, are made of stainless steel and therefore especially well suited to refrigeration systems in the food industry and where aggressive environments exist. These thermostatic expansion valves have been developed and designed especially for easy and quick soldering into hermetic refrigeration systems.

The valves are offered in the following rated capacities  
From 0.5 kW / 0.14 TR, up to 17.0 kW / 4.8 TR  
R407C (TU)  
From 19.0 kW / 5.4 TR up to 28.5 kW / 8.1 TR  
R407C (TC).

### Features

- **Bi-metal connections**
  1. Fast and easy brazing process – no wet wrap needed.
  2. Braze alloys with as little as 5% Ag can be used.
- **Compact, lightweight design**
  1. Flexible and easy integration in any system.
- **Stainless steel**
  1. High body strength.
  2. High corrosion resistance.
  3. High vibration resistance
- **Laser-welded power element**
  1. Ensures diaphragm's structural integrity and lengthens life.
- **Stainless steel capillary tube**
  1. Flexible lightweight capillary tube, tolerates more bending for trouble-free installation and longer life.
  2. Greater resistance to vibration during operation because of low weight.
- **Laser engraving**
  1. Durable positive valve identification; no label that peels off over time.
  2. Customer-specific engraving available on request.
- **Fully hermetic brazed and laser-welded design**
  1. Hermetic valve in accordance with EU F-gas Regulation EU 517/2014.
  2. No external leakage which saves costs on maintenance and refrigerant loss.
  3. Protecting the environment and climate
- **Manufactured according to IATF16949**
  1. Quality and reliability that are second to none.

## Data sheet | Thermostatic expansion valve TU and TC

Thermostatic expansion valves regulate the amount of refrigerant that is injected into the evaporator. It does this to keep a constant superheat level at the outlet of the evaporator, thereby preventing liquid refrigerant from entering the suction line and possibly causing damage to the compressor.

### Typical applications for TU and TC valves are:

- Conventional refrigeration systems
- Heat pump systems
- Air conditioning systems
- Specialty refrigeration appliances
- Liquid chillers
- Ice machines
- Transport refrigeration

### Application Diagram

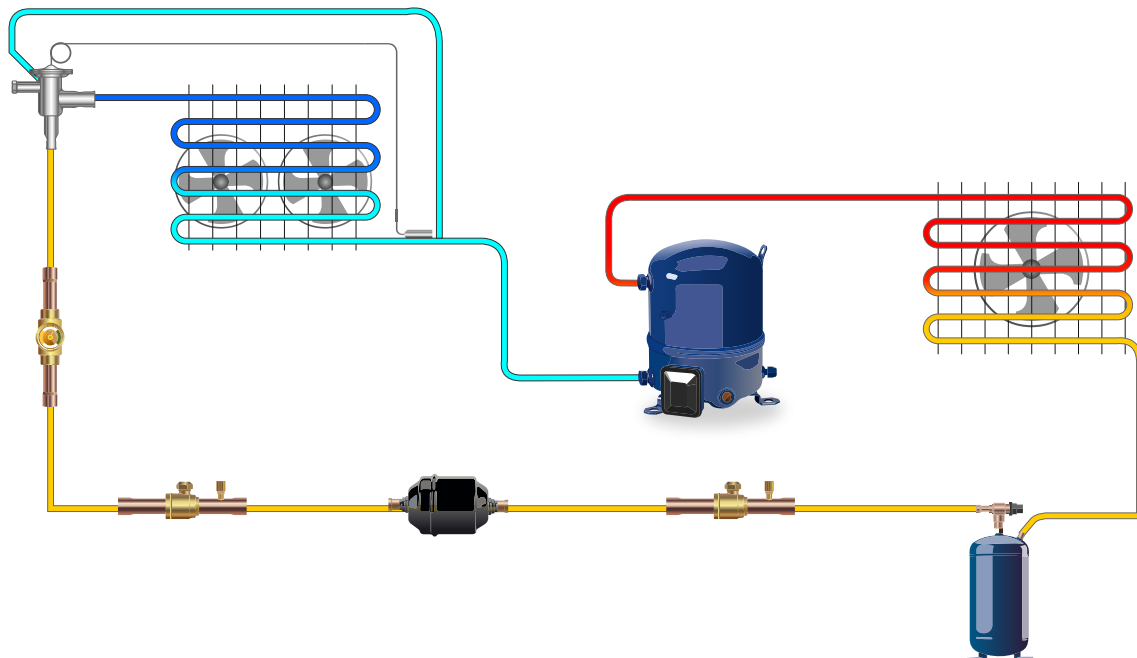

**Technical data**

Charges available for following refrigerants	R290, R134a, R513A, R404A, R407A, R407C, R407F, R448A, R449A, R507, R410A, R452A, R600a TU and TC valves are continually evaluated for use with newer refrigerants. For further information please contact Danfoss.
Ignition assessment	Positive. Zone 2 (Category 3, IIA) TUA/TUAE and TCAE only approved for A1 refrigerants
Complies with PED	Yes, fluid group 2, Article 4 paragraph 3, DN < 25 (inner bore)
Standard charge ranges with MOP	-40 – +10 °C / -40 – +50 °F MOP +15 °C / + 60 °F -40 – -5 °C / -40 – +25 °F MOP 0 °C / +32 °F -60 – -25 °C / -75 – -15 °F MOP -20 °C / -4 °F (not for R134a and R513A) For other ranges, please contact Danfoss.
Max. working pressure PS/MWP	TU (non R410A): 34 bar(g) / 500 psi(g) TU (R410A): 45.5 bar(g) / 660 psi(g) TC (all): 45.5 bar(g) / 660 psi(g)
Connection type	Solder, ODF
Connection sizes, Angleway	Inlet: ¼ in, 3/8 in, 6 mm, 10 mm Outlet: 3/8 in, ½ in, 5/8 in, 10 mm, 12 mm, 16 mm
Connection sizes, Straightway	Inlet: ¼ in, 3/8 in, ½ in, 6 mm, 10 mm, 12 mm Outlet: 3/8 in, ½ in, 5/8 in, 10 mm, 12 mm, 16 mm
Connection sizes, [External equalization]	¼ in, 6 mm
Orifices, TUB(E), TUC(E)	X, 0, 1, 2, 3, 4, 5, 6, 7, 8, 9
Orifices TUA(E)	1, 2, 3, 4, 5, 6, 7, 8, 9
Orifices TCAE, TCBE, TCCE	1, 2, 3
Bleed	15% (of nominal capacity) available. For 30%, contact Danfoss.
Biflow operation	With flow in the opposite direction, the rated capacity is reduced by up to 15%.
Biflow not recommended in	TU with orifice 9 TC with orifice 3 All valves with MOP charges
Biflow not possible in	All valves with internal equalization
Environmental transport/storage temperature and humidity	Max. +65 °C / +150 °F, Humidity: <100% RH
Max. body temperature (mounting/operation)	+120°C / +250°F (short lived peak: +150°C / +300°F)
Min. body temperature	See Evaporating temperature range low end.
Max. bulb temperature (operation)	Standard valves: +100°C / +212°F Valves with MOP charges: +150°C / +300°F
Static superheat (SS)	Standard 4K / 7.2°F Customer-specific settings and non-adjustable valves are available. Please contact Danfoss.
Material of product	Body: Stainless steel Capillary tube: Stainless steel Connector: Bimetal (stainless steel and copper)
Standard capillary tube lengths	TU: 0.8 m / 31.5 in TC: 0.9 m / 35 in
Special capillary tube lengths available	0.3 m / 11.8 in, 0.45 m / 18.0 in and 1.5 m / 59 in
Inlet strainer	TU orifice X - 4 = 100 mesh / All other TU and TC = 50 mesh / TU and TC angle = 80 mesh
Serviceable	No
Corrosion	Passed salt spray test (EN ISO 9227 NSS) and ASTM prohesion (ASTM G85) test. Both 2000 hours

**Ordering**



Coolselector<sup>®</sup>2 is a Danfoss calculation and selection software, designed to make selection processes for all refrigeration projects easier and less time-consuming. For fast and precise selection of valve, use Danfoss' CoolSelector2<sup>®</sup> software. You can download it from <http://coolselector.danfoss.com>

Product catalog <https://www.danfoss.com/en/products/valves/dcs/thermostatic-expansion-valves/tu-thermostatic-expansion-valves/>

**Accessories**

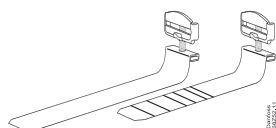

Bulb strap for TU, TC, T2			
Code no.	Description	Pack mode	Quantity / pack
068U3505	Bulb strap 0.4 mm Max. 28 mm tube	I	45
068U3506	Bulb strap 0.4 mm Max. 50 mm tube	I	45
068U3507	Bulb strap 0.4 mm Max. 28 mm tube	M	25
068U3508	Bulb strap 0.4 mm Max. 50 mm tube	M	25

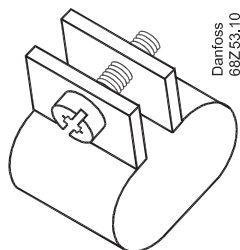

Bulb strap for TU, TC, T2			
Code no.	Description	Pack mode	Quantity / pack
068U3509	OEM bulb strap 3/8 in tube	I	45
068U3510	OEM bulb strap 1/2 in tube	I	45
068U3511	OEM bulb strap 5/8 in tube	I	45

I = Industrial pack (OEM)  
M = Multipack (Wholesaler)

Spare parts  
TUA / TUAE and TCAE

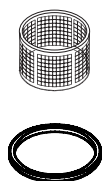

Code no.	Description	Pack mode	Quantity pack
068U1706	Inlet screen TUA/TUAE 0 - 4	Industrial packing	24
068U0016	Inlet screen TUA/TUAE 5 - 9, TCAE 1 - 3	Industrial packing	24
068U0015	Gasket	Industrial packing	24

**Note:** To secure tightness, the orifice gasket must be changed each time the orifice is disassembled

**Data sheet | Thermostatic expansion valve TU and TC**
**Nominal capacity data**

Type	Orifice	R410A		R134a		R407C		R404A/R507		R290		R22	
		[kw]	[TR]	[kw]	[TR]	[kw]	[TR]	[kw]	[TR]	[kw]	[TR]	[kw]	[TR]
TU	0X	0.74	0.21	0.32	0.09	0.50	0.15	0.37	0.11	0.49	0.14	0.48	0.13
TU	00	0.99	0.28	0.42	0.12	0.66	0.19	0.49	0.14	0.64	0.18	0.63	0.18
TU	01	1.3	0.38	0.61	0.17	0.94	0.27	0.71	0.21	0.94	0.27	0.92	0.26
TU	01	1.7	0.49	0.72	0.20	1.1	0.33	0.87	0.26	1.1	0.32	1.1	0.31
TU	03	2.1	0.61	0.95	0.27	1.5	0.42	1.1	0.33	1.5	0.41	1.4	0.40
TU	04	4.1	1.2	1.6	0.45	2.5	0.74	2.0	0.59	2.6	0.72	2.5	0.70
TU	05	5.3	1.5	2.1	0.60	3.4	0.98	2.7	0.79	3.4	0.96	3.4	0.93
TU	06	8.5	2.4	3.4	0.94	5.3	1.5	4.2	1.2	5.3	1.5	5.3	1.5
TU	07	11.2	3.2	4.4	1.3	7.0	2.0	5.6	1.6	7.0	2.0	7.0	1.9
TU	08	15.8	4.5	6.5	1.8	10.2	3.0	8.0	2.4	10.2	2.9	10.1	2.8
TU	09	23.1	6.6	9.0	2.5	14.0	4.1	11.3	3.4	14.3	4.1	14.1	4.0
TC	01	21.2	6.1	13.0	3.7	17.8	5.1	13.0	3.8	19.1	5.4	18.3	5.1
TC	02	24.5	7.0	14.9	4.2	20.4	5.9	15.1	4.4	22.2	6.3	21.2	5.9
TC	03	30.6	8.9	18.6	5.2	25.2	7.3	18.9	5.6	27.9	7.9	26.7	7.4

The rated capacity is based on:

Evaporating temperature  $t_e = 4.4\text{ °C} / 40\text{ °F}$

Liquid teperature  $t_l = 37\text{ °C} / 98\text{ °F}$

Condensing temperature  $t_c = 38\text{ °C} / 100\text{ °F}$

Type	Orifice	R407F		R407A		R448A		R449A		R513A		R452A	
		[kw]	[TR]	[kw]	[TR]	[kw]	[TR]	[kw]	[TR]	[kw]	[TR]	[kw]	[TR]
TU	0X	0.58	0.17	0.49	0.14	0.48	0.14	0.47	0.14	0.28	0.08	0.28	0.08
TU	00	0.76	0.22	0.65	0.19	0.63	0.18	0.61	0.18	0.36	0.10	0.31	0.09
TU	01	1.1	0.32	0.94	0.28	0.93	0.27	0.90	0.26	0.53	0.15	0.46	0.13
TU	01	1.4	0.39	1.1	0.33	1.1	0.33	1.1	0.31	0.62	0.18	0.55	0.16
TU	03	1.7	0.50	1.5	0.43	1.4	0.42	1.4	0.41	0.82	0.23	0.72	0.20
TU	04	3.1	0.91	2.6	0.77	2.5	0.74	2.4	0.71	1.4	0.40	1.3	0.36
TU	05	4.2	1.2	3.5	1.0	3.4	1.0	3.2	1.0	1.8	0.53	1.7	0.48
TU	06	6.5	1.9	5.5	1.6	5.3	1.5	5.1	1.5	2.9	0.83	2.7	0.75
TU	07	8.6	2.5	7.2	2.1	7.0	2.0	6.7	2.0	3.8	1.1	3.5	0.99
TU	08	12.4	3.6	10.5	3.1	10.1	3.0	9.8	2.9	5.6	1.6	5.1	1.4
TU	09	17.1	5.0	14.4	4.2	13.9	4.1	13.6	4.0	7.7	2.2	7.2	2.1
TC	01	20.6	5.9	17.6	5.1	17.6	5.1	16.9	4.9	11.5	3.3	12.6	3.6
TC	02	24.0	6.9	20.3	5.9	20.3	5.9	19.3	5.6	13.2	3.8	14.5	4.1
TC	03	30.1	8.7	25.2	7.4	25.1	7.4	23.9	7.0	16.5	4.7	18.1	5.2

The rated capacity is based on:

Evaporating temperature  $t_e = 4.4\text{ °C} / 40\text{ °F}$

Liquid teperature  $t_l = 37\text{ °C} / 98\text{ °F}$

Condensing temperature  $t_c = 38\text{ °C} / 100\text{ °F}$

**Identification**

Main valve data is given on the power element (Fig. 1 and 2), on the valve body (Fig. 3) and on the orifice assembly (Fig. 4).

For valves and separate orifices with bleed (optional), the bleed size is marked on the valve body or orifice assembly respectively.

BP15 (= 15% bleed of nominal capacity).

For valves with fixed superheat setting (types TUC, TUCE or TCCE), the static superheat is printed on the power element (e.g. SS 4°C/7.2°F).

All standard valves are marked with EAC, in case they need to be exported to Eurasia.

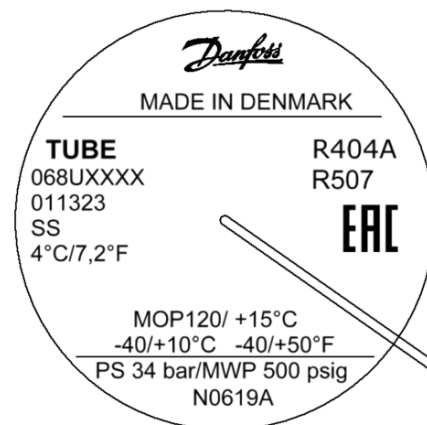

**Fig. 1 Power element, TUBE**

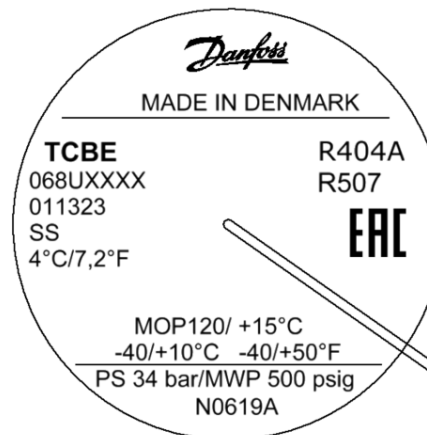

**Fig. 2 Power element, TCBE**

Power element, data example, Fig. 1 and 2:	
TUBE	= Type (E = external pressure equalization)
068Uxxxx	= Code number
R404A/R507	= Refrigerant
MOP 55/+15°C	= MOP-point in psig and °C (optional)
-40/+10°C	= Evaporating temperature range in °C
-40/+50°F	= Evaporating temperature range in °F
PS 34 bar/MWP 500 psig	= Max. working pressure in bar and psig
N0619A	= Date marking (N = Nordborg, week 06, year 2019, weekday A = Thursday)

Valve body, data example, Fig. 3:	
"arrow"	= Normal flow direction
Inch	= Connection in Inches (MM = millimeters)
BP15	= 15% bleed (optional)
Orifice 1	= Orifice number 1
5.40 TR	= Rated capacity Qnom, in tons of refrigeration
19.0 kW	= Rated capacity Qnom, in kW

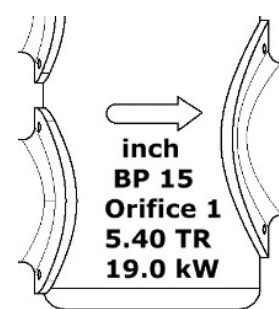

**Fig. 3 Valve body, TUBE and TCBE**

Orifice assembly, data example (Fig. 4 and 5)	
TU	= Orifice for valve type (TUA or TCA)
5	= Orifice assembly number
068Uxxxx	= Code number, orifice with filter and gasket
0619	= Date marking (week 06, year 19)

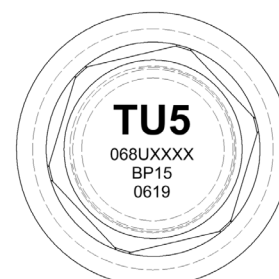

**Fig. 4 TUA / TCA orifice**

**Design**

TU and TC valves are basically identical, except for the larger diaphragm on the TC. The larger diaphragm allows for more travel of the orifice cone, which gives the TC valve more capacity than the TU valve.

TU and TC valves are available in both Straightway and Angleway versions. TUA(E) and TCAE only as straight flow.

Angle flow (fixed orifice)



Straight flow (fixed orifice)

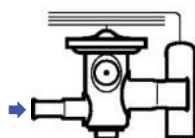

Straight flow (exchangeable orifice)

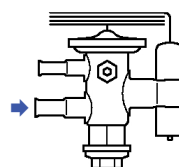

Type	Angleway		Straightway	
	Internal pressure equalization	External pressure equalization	Internal pressure equalization	External pressure equalization
TUB/TUBE/TCBE Adjustable superheat				
TUC/TUCE/TCCE Non-adjustable superheat				
TUA/TUAE/TCAE Adjustable superheat and exchangeable orifice				

**TU Angleyway**

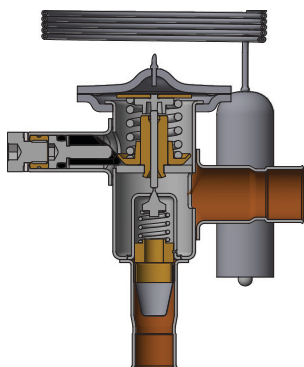

**TU Straightway**

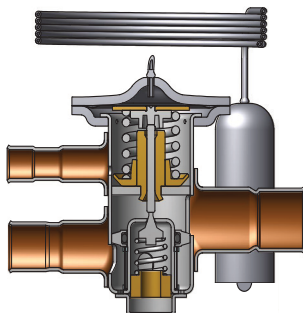

**TUA / TUAE (incl. orifice)**

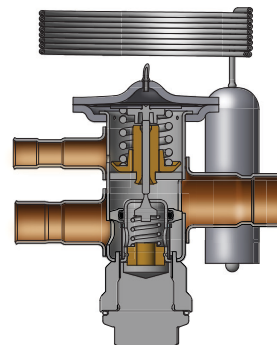

**TC Angleyway**

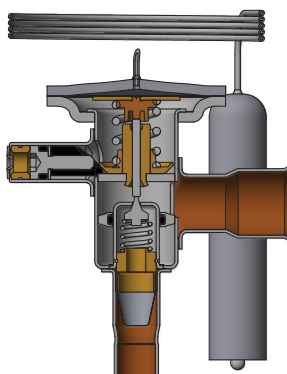

**TC Straightway**

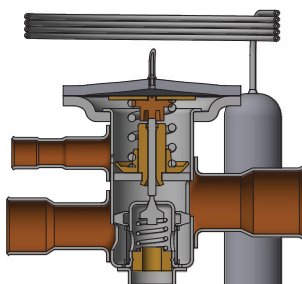

**TCAE (incl. orifice)**



**Function**

Thermostatic expansion valves maintain a constant superheat level at the evaporator outlet. It does this by controlling the amount of refrigerant that is injected into the evaporator, taking both the evaporator load and ambient temperatures into consideration. This both optimizes the efficiency of the refrigeration system and prevents liquid refrigerant from entering the suction line, possibly causing damage to the compressor. Particularly when compared to systems that use capillary tubes, the thermostatic expansion valve will offer a significant energy saving.

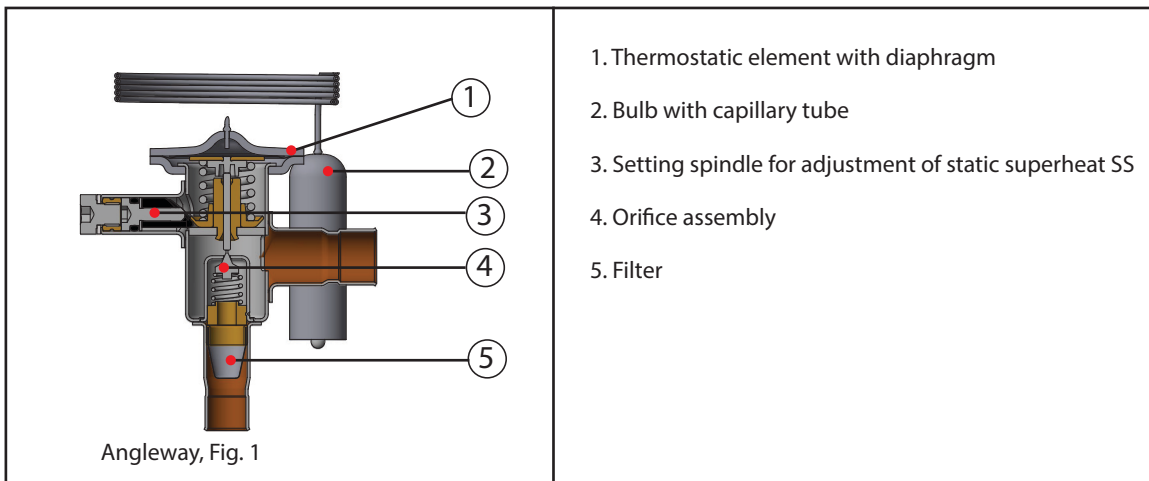

1. Thermostatic element with diaphragm
2. Bulb with capillary tube
3. Setting spindle for adjustment of static superheat SS
4. Orifice assembly
5. Filter

Angleway, Fig. 1

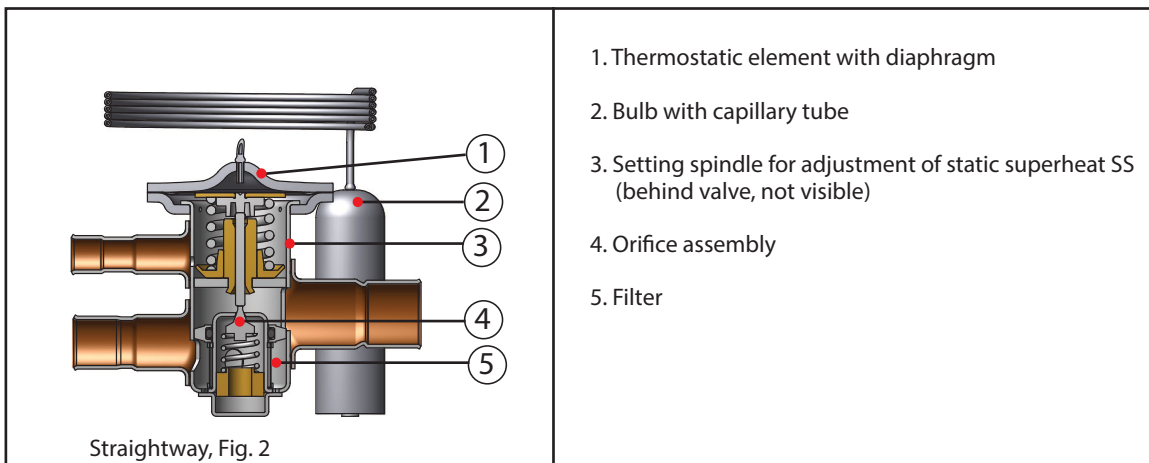

1. Thermostatic element with diaphragm
2. Bulb with capillary tube
3. Setting spindle for adjustment of static superheat SS (behind valve, not visible)
4. Orifice assembly
5. Filter

Straightway, Fig. 2

Superheat, see Fig. 3  
 SS = Static superheat  
 OS = Opening superheat  
 SH = SS + OS = Total superheat  
 Q<sub>nom</sub> = Rated capacity  
 Q<sub>max</sub> = Maximum capacity

Static superheat (SS) can be adjusted by turning the setting spindle (3), see fig. 1 and 2 (TUB/TUBE/TCBE) Static Superheat cannot be adjusted on TUC/TUCE/TCCE.

The superheat setting is 4K for all standard valves. The opening superheat is 4K, measured from when the valve begins to open to when the valve gives its rated capacity (Q<sub>nom</sub>).

Example:  
 Static superheat  
 Opening Superheat  
 Total superheat

SS = 4K  
 OS = 4K  
 SH = 4 + 4 = 8K

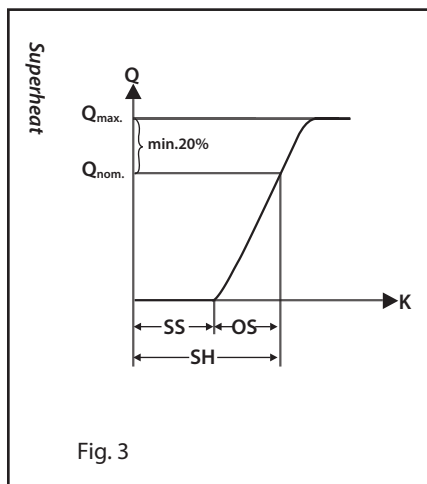

Fig. 3

## Data sheet | Thermostatic expansion valve TU and TC

### How to select a TU or TC thermostatic expansion valve.

**Example:** Refrigerant: R134a  
 Cooling capacity: 3KW  
 Evaporating temperature: -10 °C  
 Condensing temperature: 35 °C  
 Total (useful) superheat: 8K  
 Subcooling: 6K

This guide will help select a thermostatic expansion valve based on the above system parameters using the Coolselector tool.

- Step 1:** Open the Coolselector tool and select thermostatic expansion valve. Coolselector can be downloaded from <https://www.danfoss.com/en/service-and-support/downloads/dcs/coolselector-2/> or used online on <http://coolselectoronline.danfoss.com>
- Step 2:** Select TU/TC from product families and the refrigerant. For this example: R134a.
- Step 3:** Fill in the operating conditions at the top as per the system parameters stated in the example.

Operating conditions:

<b>Capacity:</b> Cooling capacity: 3,000 kW Mass flow in line: 69,62 kg/h Heating capacity: 3,844 kW	<b>Evaporation:</b> Temperature: -10,0 °C Useful superheat: 4,0 K Additional superheat: 0 K	<b>Condensation:</b> Temperature: 35,0 °C Subcooling: 6,0 K Additional subcooling: 0 K	<b>Additional:</b> <input type="checkbox"/> Discharge temperature: 55,4 °C
---	--	---	---

**Selection criteria:**

Load: 100 %  
 Distributor pressure drop: 0 bar

- Step 4:** Now select the appropriate orifice size from the list provided by the tool. For this example, the tool suggests TU-7, which is the valve size closest to 100% load.

Liquid line (Dry expansion system. R134a. TXV).

**Selection: TU - 7    No code numbers selected**

Selected	Type	NS	Range	Nominal capacity [kW]	Min. capacity [kW]	Load [%]	DP [bar]	Velocity, in [m/s]	Result
<input type="radio"/>	TU - 5	9,53	N	1,576	0,394	190	6,862	0,33	⚠
<input type="radio"/>	TU - 6	9,53	N	2,445	0,611	123	6,862	0,33	⚠
<input checked="" type="radio"/>	TU - 7	9,53	N	3,239	0,810	93	6,862	0,33	✓
<input type="radio"/>	TU - 8	9,53	N	4,813	1,203	62	6,862	0,33	✓
<input type="radio"/>	TU - 9	9,53	N	6,587	1,647	46	6,862	0,33	✓

**Note:**

- Always remember to include sub cooling in the selection parameters. It is important for TXV selection. When all other parameters remain constant, an increase in sub cooling will increase the capacity of the thermostatic expansion valve. Insufficient sub cooling can create flash gas before the valve and high sub cooling can create lesser flash gas after the valve.
- Coolselector determines pressure drop across the valve based on the condensing and evaporating temperatures. If the system is using a distributor, has valves in the liquid line or height variations between evaporator and condenser, the pressure drops from these components must be summarized, and given as input to the tool, using the "Distributor pressure drop" field. The capacity of the thermostatic expansion valve is influenced by these pressure drops.

## Data sheet | Thermostatic expansion valve TU and TC

**Step 5:** The code number for the valve can be selected based on additional parameters like specific charge, equalization, connector type, connection size etc. at the code number selection tab. The performance details will also be shown in detail under the Performance details tab.

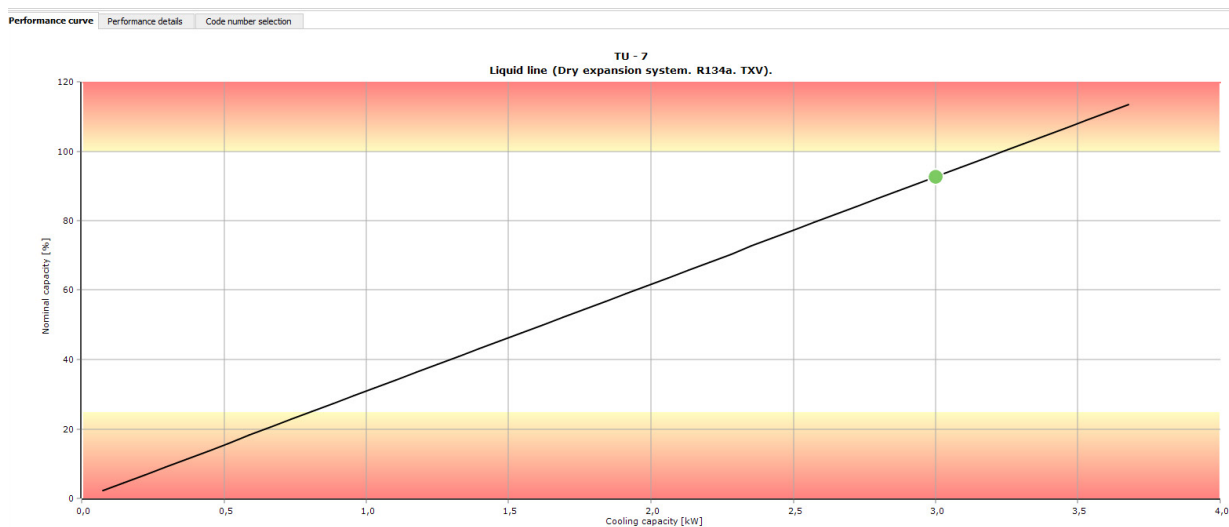

**Step 6:** For list of code numbers, click the “Code number selection” tab.

Performance curve | Performance details | **Code number selection**

Documents and Visuals... Selected code numbers: (068U4293,068U4102) Clear filters

Selection: TC/AE: Thermostatic expansion valve

Code Number	Connections	Type	Orifice size	MOP Point [psig]	MOP Point [°C]	Equalization size [mm]	Equalization size [in]	Capillary tube length [mm]	Static Superheat (SS) [°C]	Quantity
068U4293	ANSI soldering ODF, Inlet: 1/2", Outlet: 5/8"	TC/AE					1/4 IN	1500.0	4.0	1
068U4295	ANSI soldering ODF, Inlet: 1/2", Outlet: 5/8"	TC/AE		MOP 55	15.0		1/4 IN	1500.0	4.0	1
068U4219	ANSI soldering ODF, Inlet: 1/2", Outlet: 5/8"	TCBE	3				1/4 IN	900.0	4.0	1
068U4292	ANSI soldering ODF, Inlet: 3/8", Outlet: 5/8"	TC/AE					1/4 IN	1500.0	4.0	1
068U4296	DIN-EN soldering ODF, Inlet: 10, Outlet: 16	TC/AE			6.0			1500.0	5.0	1
068U4297	DIN-EN soldering ODF, Inlet: 12, Outlet: 16	TC/AE			6.0			1500.0	5.0	1
068U4299	DIN-EN soldering ODF, Inlet: 12, Outlet: 16	TC/AE		MOP 55	15.0			1500.0	4.0	1
068U4227	DIN-EN soldering ODF, Inlet: 12, Outlet: 16	TCBE	3		6.0			900.0	5.0	1
068U4231	DIN-EN soldering ODF, Inlet: 12, Outlet: 16	TCBE	3	MOP 55	15.0	6.0		900.0	4.0	1
068U4513	DIN-EN soldering ODF, Inlet: 12, Outlet: 16	TCBE	3	MOP 55	15.0	6.0		900.0	4.0	45

Common values:

Attribute	Value
Approval	EAC,LLC CDC TYSK
Parts included	Bulb strap
Body material	Stainless steel
Max. Working Pressure [bar]	45.5
Equalization connection type	SOLDER, ODF
Temperature range [°C]	-40.0 - 10.0
Direction	Straightway
Product name	Thermostatic expansion valve

Selection: Orifice, Orifice for expansion valve

Code Number	Bleed (%)
068U4102	
068U4099	15.0

Common values:

Attribute	Value
Approval	EAC,LLC CDC TYSK
Quantity	1
Used for product	TC/AE
Body material	Stainless steel
Direction	Straightway
Orifice size	3
Product name	Orifice for expansion valve
Type	Orifice

Data sheet | Thermostatic expansion valve TU and TC

Dimensions

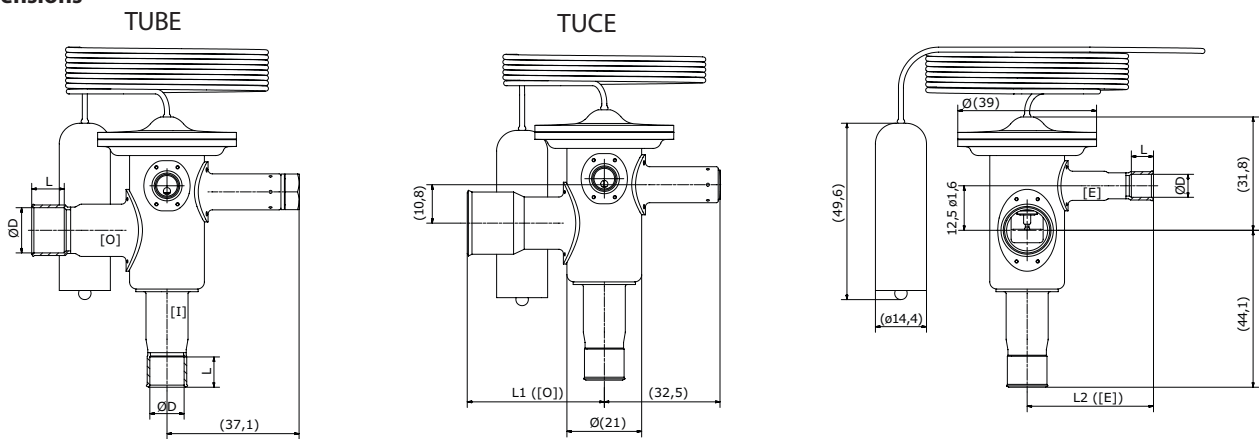

Con. / Dim.	Size	[ØD]	[ØD] tolerance	[L]	[L] tolerance	[L1] ([O])	[L1] tolerance	[L2] ([E]; [I])	[L2] tolerance																																													
Equalization [E]	6 mm	6.00	±0.155 ±0.065	7	±1.2			35.5	±2																																													
	1/4 in	6.35		7	±1.2					Inlet [I]	6 mm	6.00	7	±1.2					1/4 in	6.35	7	±1.2	3/8 in	9.52	8	±1.2	10 mm	10.00	9	±1.2	1/2 in	12.70	10	±1.4	Outlet [O]	3/8 in	9.52	8	±1.2	38.5	±2			12 mm	12.00	10	±1.4	1/2 in	12.70	10	±1.4	41.5	±2	
Inlet [I]	6 mm	6.00		7	±1.2																																																	
	1/4 in	6.35		7	±1.2																																																	
	3/8 in	9.52		8	±1.2																																																	
	10 mm	10.00		9	±1.2																																																	
	1/2 in	12.70		10	±1.4																																																	
Outlet [O]	3/8 in	9.52		8	±1.2	38.5	±2																																															
	12 mm	12.00		10	±1.4																																																	
	1/2 in	12.70		10	±1.4	41.5	±2																																															
	5/8 in	15.88		12	±1.4																																																	

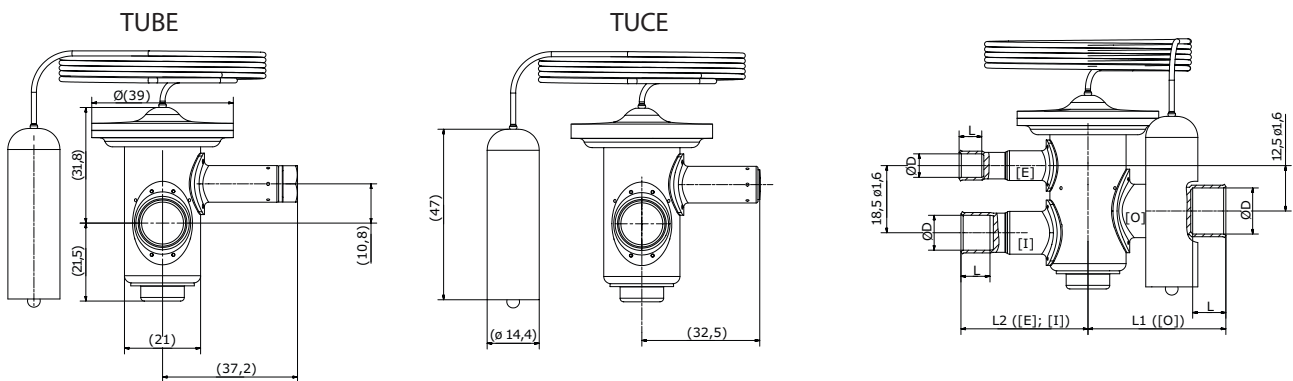

Con. / Dim.	Size	[ØD]	[ØD] tolerance	[L]	[L] tolerance	[L1] ([O])	[L1] tolerance	[L2] ([E]; [I])	[L2] tolerance																																													
Equalization [E]	6 mm	6.00	±0.155 ±0.065	7	±1.2			35.5	±2																																													
	1/4 in	6.35		7	±1.2					Inlet [I]	6 mm	6.00	7	±1.2					1/4 in	6.35	7	±1.2	3/8 in	9.52	8	±1.2	10 mm	10.00	9	±1.2	1/2 in	12.70	10	±1.4	Outlet [O]	3/8 in	9.52	8	±1.2	38.5	±2			12 mm	12.00	10	±1.4	1/2 in	12.70	10	±1.4	41.5	±2	
Inlet [I]	6 mm	6.00		7	±1.2																																																	
	1/4 in	6.35		7	±1.2																																																	
	3/8 in	9.52		8	±1.2																																																	
	10 mm	10.00		9	±1.2																																																	
	1/2 in	12.70		10	±1.4																																																	
Outlet [O]	3/8 in	9.52		8	±1.2	38.5	±2																																															
	12 mm	12.00		10	±1.4																																																	
	1/2 in	12.70		10	±1.4	41.5	±2																																															
	5/8 in	15.88		12	±1.4																																																	

TUAE

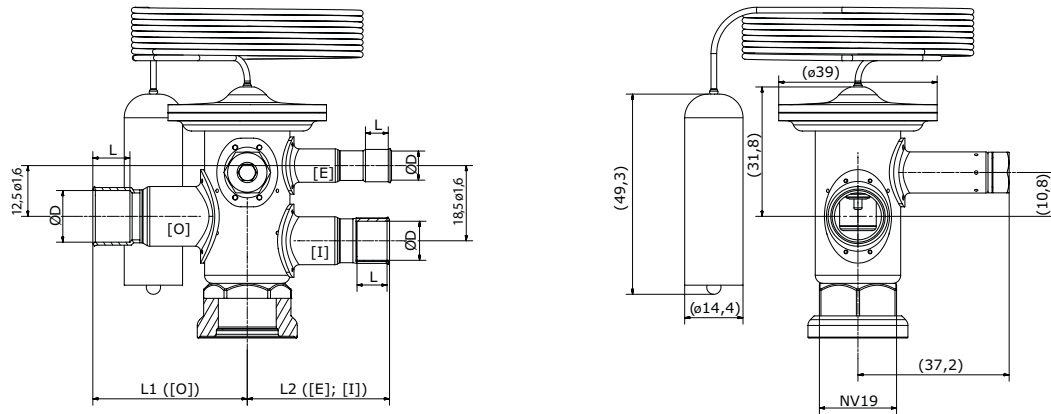

Con. / Dim.	Size	[ØD]	[ØD] tolerance	[L]	[L] tolerance	[L1] ((O))	[L1] tolerance	[L2] ((E); [I])	[L2] tolerance
Equalization [E]	6 mm	6.00	±0.155 ±0.065	7	±1.2			35.5	±2
	1/4 in	6.35		7	±1.2				
Inlet [I]	6 mm	6.00		7	±1.2			38.5	±2
	1/4 in	6.35		7	±1.2				
	3/8 in	9.52		8	±1.2				
	10 mm	10.00		9	±1.2				
Outlet [O]	1/2 in	12.70		10	±1.4			38.5	±2
	3/8 in	9.52		8	±1.2	38.5	±2		
	12 mm	12.00		10	±1.4				
	1/2 in	12.70		10	±1.4				
	5/8 in	15.88	12	±1.4	41.5	±2			

TCBE

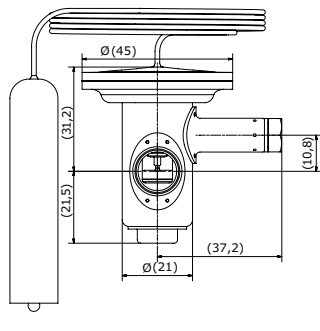

TCCE

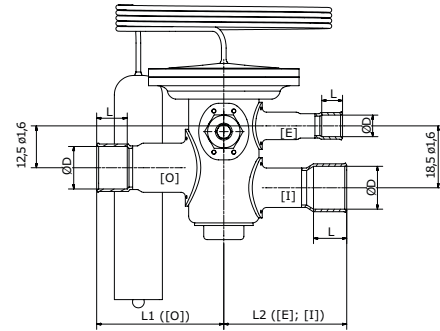
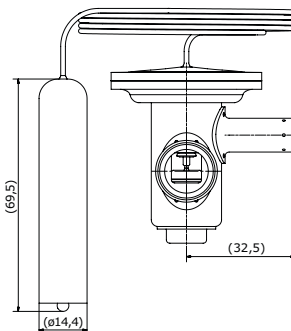

Con. / Dim.	Size	[ØD]	[ØD] tolerance	[L]	[L] tolerance	[L1] ((O))	[L1] tolerance	[L2] ((E); [I])	[L2] tolerance
Equalization [E]	6 mm	6.00	±0.155 ±0.065	7	±1.2			35.5	±2
	1/4 in	6.35		7	±1.2				
Inlet [I]	6 mm	6.00		7	±1.2			38.5	±2
	1/4 in	6.35		7	±1.2				
	3/8 in	9.52		8	±1.2				
	10 mm	10.00		9	±1.2				
Outlet [O]	1/2 in	12.70		10	±1.4			38.5	±2
	3/8 in	9.52		8	±1.2	38.5	±2		
	12 mm	12.00		10	±1.4				
	1/2 in	12.70		10	±1.4				
	5/8 in	15.88	12	±1.4	41.5	±2			

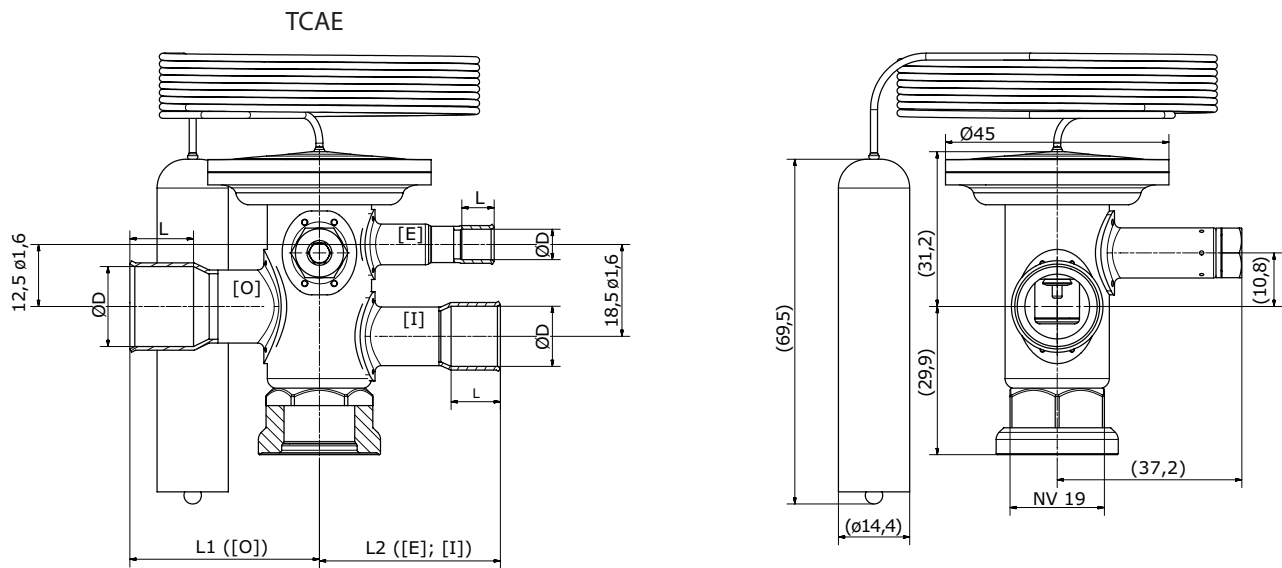

Con. / Dim.	Size	[ØD]	[ØD] tolerance	[L]	[L] tolerance	[L1] ([O])	[L1] tolerance	[L2] ([E]; [I])	[L2] tolerance
Equalization [E]	6 mm	6.00	±0.155 ±0.065	7	±1.2			35.5	±2
	1/4 in	6.35		7	±1.2				
Inlet [I]	6 mm	6.00		7	±1.2				
	1/4 in	6.35		7	±1.2				
	3/8 in	9.52		8	±1.2				
	10 mm	10.00		9	±1.2				
Outlet [O]	1/2 in	12.70		10	±1.4			38.5	±2
	3/8 in	9.52		8	±1.2				
	12 mm	12.00		10	±1.4	38.5	±2		
	1/2 in	12.70		10	±1.4				
	5/8 in	15.88		12	±1.4	41.5	±2		

### Thermostatic expansion valves TU and TC

#### Operation and function.

##### Superheat

Superheat is the controlling parameter of a TXV. Superheat, measured at the evaporator outlet, is defined as the number of degrees the refrigerant vapor is heated above its saturation temperature (boiling point), at a specific pressure. Liquid entering the compressor causes serious damage. To prevent this, the TXV will maintain a certain minimum superheat.

When discussing superheat in relation to TXV valve operation, the following terms are used:

##### Static superheat

Static superheat, SS is the superheat above which the valve will begin to open.

##### Opening superheat

Opening superheat, OS, is the amount of superheat above static superheat, SS, required to produce a given valve capacity.

##### Total superheat

Total superheat is static superheat plus opening superheat, and is what is measured at the evaporator outlet.

##### Subcooling

Subcooling, measured at the condenser outlet, is defined as the number of degrees a liquid refrigerant is cooled below its saturation temperature (boiling point), at a specific pressure.

Subcooling is necessary to prevent flash gas forming in the liquid line. Depending on system design, various levels of subcooling may be needed. In most cases, 2 to 5K of subcooling is

adequate. If flash gas forms in the liquid line, the capacity of the TXV will be greatly reduced.

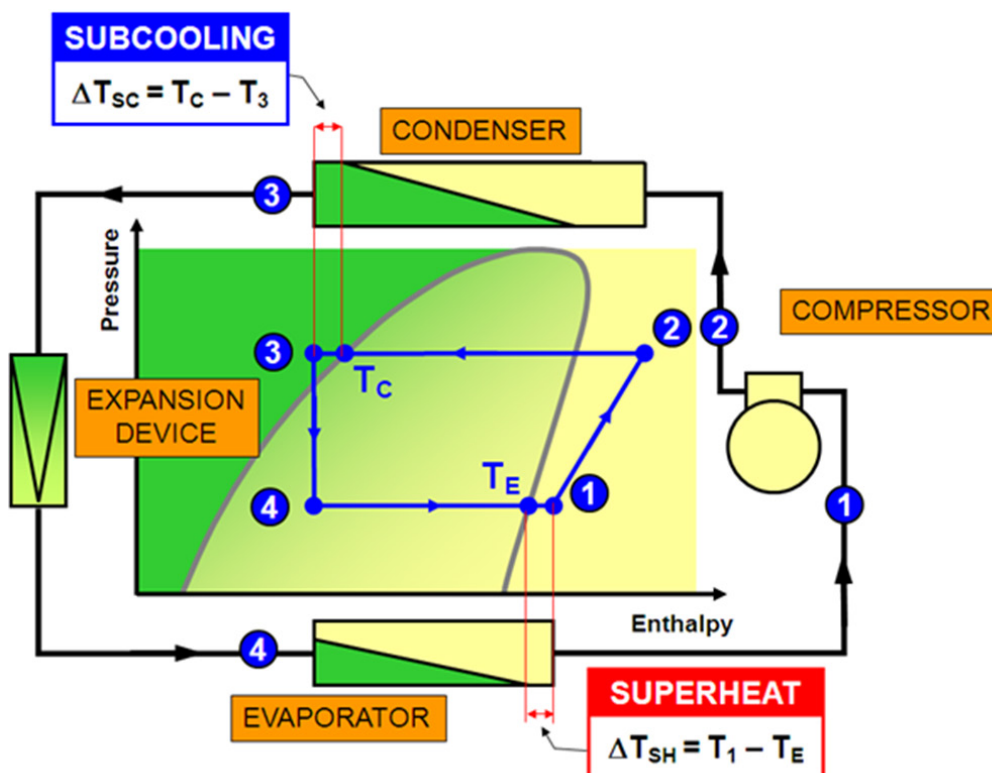

## Data sheet | Thermostatic expansion valve TU and TC

### Bi-flow

Bi-flow function is sometimes used in systems with 4-way reversing valves where hot gas defrosts, or heating cycles are required.

Only externally equalized TU valves with orifices X to 8 and externally equalized TC valves with orifices 1 and 2 – without MOP charges, can be used in bi-flow mode. When used in reverse direction, the rated

valve capacity will be reduced by up to 15%. Valves for bi-flow operation should be installed so that the normal refrigerant flow is towards the main evaporator

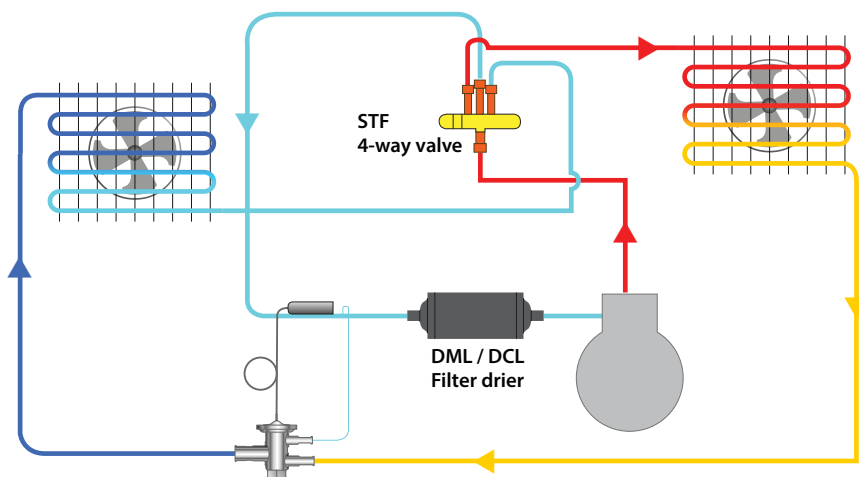

### Available charges

#### Universal charge

This is the standard charge, used in most applications. It is characterized by a very large operational evaporating temperature range, with only small variations in static superheat across the temperature range. It is available in two temperature ranges. One for normal (-40°C to +10°C / -40°F to 50°F) and one for low (-60 to -25°C / -76°F to -13°F) temperature applications.

#### MOP charge (MOP = Maximum Operating Pressure)

The MOP charge is used to protect the compressor motor against overload during start-up. A valve with MOP charge will throttle liquid injection into the evaporator and thus prevent the evaporating pressure from rising above the specified MOP point. Above the MOP point, any increase in sensor temperature results in only minimal additional opening of the expansion valve. A number of different MOP points are available.

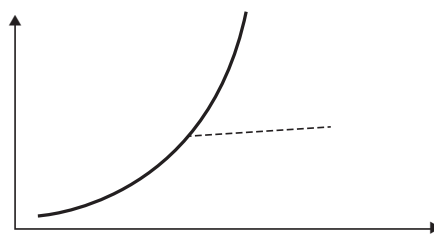

**Note:** The MOP point will change if the factory superheat setting of the expansion valve is changed. If the setting is reduced, the MOP point will go up and vice versa.

#### MAH charge

The Danfoss Marinite Anti-Hunt (MAH) charge can be used in dynamic systems, often A/C systems. Here it reduces valve hunting during evaporator load changes, thereby helping to maintain stable system superheat and improve system performance.

#### F-charge

The F-charge is designed for refrigeration systems where low total superheat is required. Valves with this charge are delivered with an optimized low static superheat setting which allows for installation with no or minimal field adjustment. The F-charge also includes the Danfoss MAH function, as described above.

#### Ice charge

The ice charge is designed with an optimized static superheat characteristic, which allows for optimal function, particularly in Ice cubers, where low superheat is required in order to fully utilize the entire evaporator coil.

#### Milk charge

The milk charge is designed for use in milk cooling tanks where a limitation of the suction pressure is required, but where an MOP valve would suffer from charge migration.



## TU stainless steel technology



### High quality

The TU is manufactured on fully automated, process-monitored production lines. Cellularized computer-monitored technology ensures uniform high quality and that, when delivered, every valve meets Danfoss quality standards and customer specifications. Cellularized production also makes possible simultaneous production of large and small quantities of standard and custom version valves.

### Benefits of stainless steel

The fact that the TU is an all-stainless steel expansion valve offers a number of benefits:

- Stainless steel is far more corrosion-resistant than traditional valve materials.
- Stainless steel valves require no surface treatment.
- Stainless steel capillary tubes are three times stronger and twenty times more resistant to vibration than copper capillary tubes.
- Stainless steel has a greater strength-to-weight ratio, making TU valves lighter and more compact.
- Stainless steel diaphragms have greater strength and corrosion resistance for a longer life.

### Danfoss precision port design

The TU thermostatic expansion valve introduces precision port design, incorporating four features that ensure superior repeatable performance over an extended valve life.

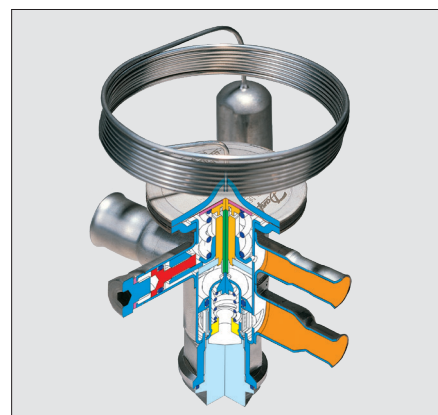

- Laser welding of the power element preserves the structural uniformity of the diaphragm, assuring consistent operation.
- A precision-machined pushrod and bushing make a practically frictionless seal with no need for a packing gland.
- The free-floating pushrod is self-aligning and eliminates binding.
- The precision-machined cone and orifice accurately meter refrigerant under all operating conditions.

### Advanced technology - fast and easy installation

The TU stainless steel thermostatic expansion valve has significant installation advantages because it is a valve designed specifically for soldering. The TU can be installed in less than half the time required for traditional brass-bodied valves. The valve connections are made of copper and stainless steel bi-metal which makes installation easy, reliable, and fast.



### No need for a wet cloth...

Bi-metal has a very low thermal conductivity, actually only 10% that of copper, so heat applied during soldering remains largely in the copper layer of the connection tube, instead of being conducted to the valve body. External cooling is unnecessary. The result is less energy consumption and better solder quality. At the same time, the diaphragm's structural integrity is preserved.

