

Data sheet

# Low pressure transmitter for industrial applications

## MBS 9200



Compact pressure transmitter program, MBS 9200 gauge version is designed for use in industrial applications e.g. crankcase and turbocharger on industrial engines, filters monitoring as well as applications within level measurement.

The program covers 4 – 20 mA output signal or ratiometric 10-90% of supply output signals and with pressure span from 40 – 400 mbar as well as bidirectional ranges..

Excellent vibration stability, robust construction, and a high degree of EMC / EMI protection equip the pressure transmitter to meet the most stringent industrial requirements.

### Features

- Compact design
- Full scale span from 40 – 400 mbar - bidirectional ranges a vailable e.g. -70 – 70 mbar etc. (lowest zero point – 150 mbar)
- Digital temperature compensated
- Output signal: 4 – 20 mA or ratiometric 10-90% of supply
- Excellent shock and vibration robustness
- Reverse polarity protection
- With build-in clipping function and self-diagnostic on request
- Reverse output on request
- Enclosure and wetted parts of stainless steel (AISI 316L)
- Customer specific versions on request
- For use in Zone 2 explosive atmosphere

**Technical data**
**Performance (EN 60770)**

						Units
Full-scale span (FSS)	40	60	100/140	150	250/400	mbar
Accuracy @ 25 °C (incl. non-linearity, hysteresis and repeatability)	≤ ± 2	≤ ± 1.5	≤ ± 1	≤ ± 0.5	≤ ± 0.5	% FSS typ.
Non-linearity (BFSL)	≤ ± 0.2	≤ ± 0.2	≤ ± 0.2	≤ ± 0.2	≤ ± 0.2	% FSS
Hysteresis and repeatability	≤ ± 0.1	≤ ± 0.1	≤ ± 0.1	≤ ± 0.1	≤ ± 0.1	% FSS
Total error band (TEB) within compensated temperature range	≤ ± 5	≤ ± 3	≤ ± 2	≤ ± 1.5	≤ ± 1.5	% FSS
Mounting position error for 180° rotation	≤ ± 1.25	≤ ± 0.8	≤ ± 0.5	≤ ± 0.35	≤ ± 0.2	% FSS
Overload pressure (static)	3.5	3.5	3.5	3.5	3.5	bar
Burst pressure	50	50	50	50	50	bar
Response time						< 2 ms
Resolution						Infinite
Durability P: 10 – 90% FS						10 × 10 <sup>6</sup> pressure cycles

Full-Scale Span (FSS) is the difference between the upper limit and the lower limit of the pressure range.  
(e.g. for pressure range -30 – 30 mbar, FSS = 60 mbar.)

**Electrical specifications**

Nom. output signal (short circuit protected)	4 – 20 mA	Ratiometric 10-90% supply
Supply voltage [U <sub>B</sub> ], reverse polarity protected	9 – 32 V DC	5 V DC +/- 10%
Supply voltage dependency	< ± 0.05% FSS / 10 V	-
Load [R <sub>L</sub> ] (load connected to 0 V)	R <sub>L</sub> ≤ (U <sub>B</sub> - 8 V) / 0.02 A	R <sub>L</sub> ≥ 1.5 kΩ
Supply current consumption	-	≤ 6 mA
Sink / Source	-	3.3 mA
Output impedance	-	≤ 25 Ω

**Environmental specifications**

Media temperature range	FPM gasket	-20 – 100°C
	NBR gasket	-25 – 85 °C
Ambient temperature range	See page 3	
Compensated temperature range	0 – 80 °C	
Transport / storage temperature range	-40 – 125 °C	
EMC - Emission	EN 61000-6-3 and EN61236-1	
EMC Immunity	EN 61000-6-2 and EN61236-1	
Vibration stability	Sinusoidal	15.9 mm-pp, 2 Hz – 25 Hz 20 g, 25 Hz – 2 kHz
	Random	7.5 g <sub>rms</sub> , 5 Hz – 1 kHz
Shock resistance	Shock	500 g / 1 ms
	Free fall	1 m
Enclosure (depending on electrical connection)	See page 3	

**Explosive atmospheres**

Zone 2 applications <sup>1)</sup>	<b>II 3G</b> <b>Ex nA IIA T3 Gc</b> <b>-10 °C &lt; Ta &lt; +85 °C</b>	EN60079-0; EN60079-15
-----------------------------------	---	-----------------------

<sup>1)</sup> When used in ATEX Zone 2 areas at low temperatures the cable and plug must be protected against impact.

**Mechanical specifications**

Net weight	0.2 – 0.3 kg
Electrical connector	See page 3
Pressure connection	see page 3
Materials, wetted parts	EN 10088; 1.4404 (AISI 316 L)

<b>Type code:</b> Electrical connection	<b>A0</b>	<b>A1</b>	<b>A6</b>	<b>A3</b>	<b>B3</b>	<b>G2</b>
<b>Type code:</b> Pressure connection	<b>FA09</b> DIN 3852_E-M 14x1.5 Gasket: DIN 3869-14		<b>GB08</b> DIN 3852_G½ Gasket: DIN 3869-21		<b>GB04</b> DIN 3852_E-G¼ Gaske: DIN 3869-14	
Recommended torque	20.25 Nm					

**Electrical connection**

Type code	<b>A0</b> <b>175301-803-A</b> <b>No plug</b>	<b>A1</b> <b>175301-803-A Pg9</b>	<b>A6</b> <b>175301-803-A</b> <b>Pg11</b>	<b>A3</b> <b>2 m screened cable</b>	<b>B3</b>	<b>G2</b>
Ambient temperature	-25 – 100 °C			-30 – 85 °C	-40 – 85 °C	
Enclosure	IP65			IP67	IP67	
Materials	Glass filled polyamid, PA 6.6			Cable screened, Polyolefin 2 m	Glass filled polyester PBT (Black) Sn plated pins	Glass filled polyester PBT (Grey) Au plated pins
Electrical connection 4-20 mA (2 wire)	Pin 1: + supply Pin 2: - supply Pin 3: Not used Earth: Connected to transmitter enclosure			Brown wire: + supply Black wire: ÷ supply Red wire: not used Orange: not used Screen: not connected to MBS enclosure	Pin 1: + Supply Pin 2: - Supply Pin 3: Not used Pin 4: Ventilation	
Electrical connection Ratiometric 10-90% supply	Pin 1: + supply Pin 2: - common Pin 3: Output Earth: Connected to transmitter enclosure			Red wire: + supply Black wire: ÷ common Brown wire: Output Orange: Not used Screen: Not connected to MBS enclosure	Pin 1: + supply Pin 2: ÷ supply/common Pin 3: + output Pin 4: Ventilation	

For proper ventilation of atmospheric reference pressure a vented cable is recommended.

**Recommended mounting position**

*Error due to different mounting than recommended can be eliminated by zeroing in user hardware*

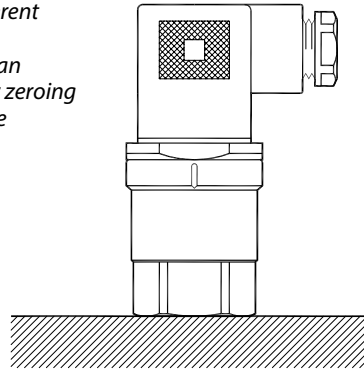

See mounting position error for 180° rotation on page 2

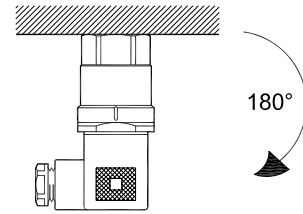

Danfoss  
8002476.10

**Ordering**

Type 9200		Gasket	
<b>Pressure range</b>		1	Gasket, FPM
-20 – 20 mbar	A 1	2	Gasket, NBR
-30 – 30 mbar	A 2		
-70 – 70 mbar	A 3		
0 – 40 mbar	B 1		
0 – 60 mbar	B 2		
0 – 100 mbar	B 3		
0 – 150 mbar	B 4		
0 – 250 mbar	B 5		
<b>Pressure reference</b>			<b>Pressure connection</b>
Gauge (relative)	1	G B 0 8	DIN 3852-E-G1/2, gasket DIN 3869-21
		G B 0 4	DIN 3852-E-G1/4, gasket DIN 3869-14
		F A 0 9	DIN 3852-E-M14 x1.5, gasket DIN 3869-14
<b>Output signal</b>			<b>Electrical connection</b>
4 – 20 mA	1	A 0	No plug (EN175301-803-A)
Ratiometric 10 - 90% of supply	6	A 1	Plug Pg 9 (EN 175301-803-A)
		A 6	Plug Pg 11 (EN 175301-803-A)
		A 3	Cable screened, Polyolefin 2 m
		B 3	Bayonet A1-3.1-Sn Ø31 ISO 151710
		G 2	Bayonet A2-3.1-AU Ø31 - Grey ISO 15170

Non-standard build-up codes on request. However, minimum order quantities may apply.  
Please contact your local Danfoss office for further information.