

Installation guide

Electric expansion valve, type ETS 250, ETS 400, ETS 500P and ETS 800P Electric regulating valve, type KVS 42

034R9799



034R9799

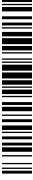

<p>Compatible refrigerants / Kältemittel Kompatibilität / Fluides compatibles / Compatibilidad de refrigerantes / 适用的冷媒</p> <p>ETS 250, 400 and KVS 42: R134a, R404A, R407A, R410A, R438A, R448A, R449A, R450A, R452A, R513A, R422B, R407C, R422D, R407F, R1234ze, R22, R507</p> <p>ETS 500P and ETS 800P: R134a, R1234ze, R513A</p>	<p>Inlet fluid temperature / Eingangstemperaturbereich / entrée température du fluide / entrada temperatura líquida / 入口流体温度</p> <p>Max. 65 °C / 149 °F Min. -40 °C / -40 °F</p>	<p>Max. working pressure / Max. zul. Betriebsüberdruck / Pression de service max. / Presión de trabajo máx. / 最大工作压力</p> <p>ETS 250, 400 and KVS 42: PS / MWP : 34 bar / 493 psig</p> <p>ETS 500P and 800P PS / MWP : 25 bar / 363 psig</p>
<p>Allowable ambient temperature / Zulässige Umgebungstemperatur / Température ambiante admissible / Temperatura ambiente permisible / 允许的运行温度</p> <p>Max. 60 °C / 140 °F Min. -40 °C / -40 °F</p>	<p>Nominal voltage / Nennspannung / Tension nominale / Voltaje nominal / 名义电压</p> <p>12 V DC</p> <p>Stepper motor type / Schrittmotortype / Type de moteur pas à pas / Tipo de motor a pasos / 步进电机形式</p> <p>Bipolar / 双极</p>	<p>Phase current / Phasenstrom / Phase électrique / Corriente de fase / 相电流</p> <p>100 mA</p> <p>Resistance / Widerstand / résistance électrique / Resistencia / 电阻</p> <p>52 Ω</p>

Flow direction
Durchflussrichtung
Sens d'écoulement
Dirección del flujo
流向

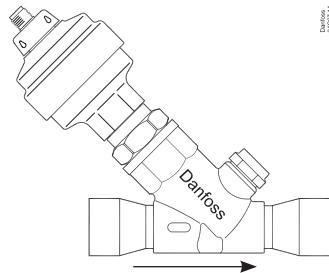

* Flow direction for liquid verification using the sight glass

ETS 250, ETS 400, ETS 500P and ETS 800P*
KVS 42 (without sight glass)

Application
Anwendung
Application
Aplicación
应用

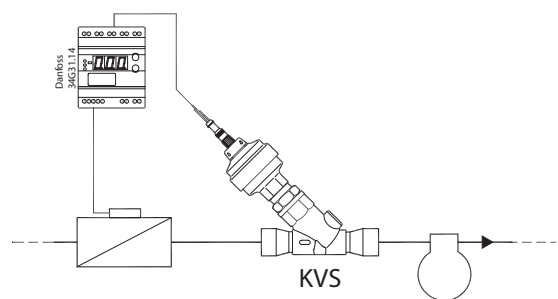
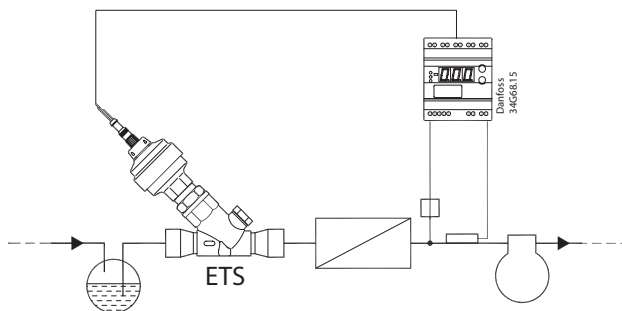

Mounting
Einbau
Montage
Instalación
安装

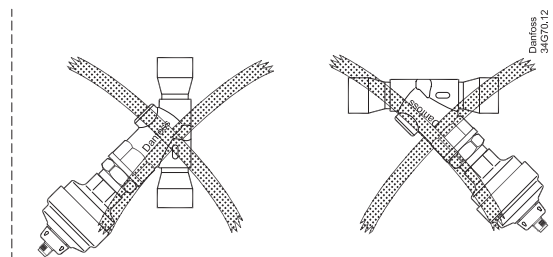
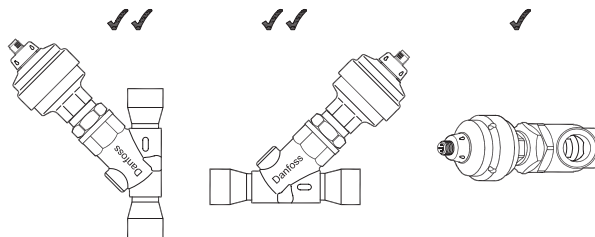

**For service only / Nur für Service-Zwecke /
Pour l'entretien uniquement /
Sólo para mantenimiento / 仅供维修之用**

**Contact Danfoss for spare parts for oil free
application**

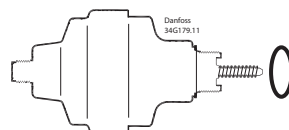

034G2087



034G2344

**Brazing
Löten
Soudure
Soldadura
焊接**

ETS 250, 400 and KVS 42

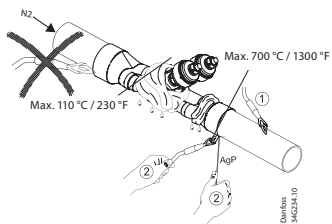
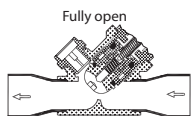
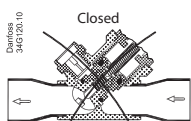
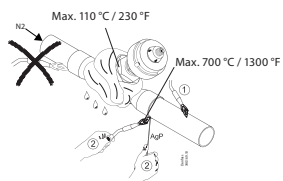

ETS 500P and 800P

N2 gas from opposite side of soldering point.
Schutzgas gegenüber der Lötstelle einströmen lassen.
Refrigidissement gaz ci-contre site de point
de soudure. Corriente de N2 desde el lado opuesto
a la soldadura. 气体冷却对面的焊点(氮气保护)

**Disassembling
Zerlegung
Désassemblage
Desmontaje
拆卸**

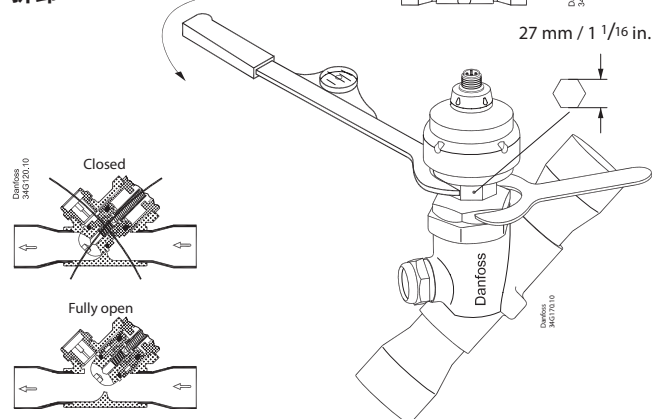

**Assembling
Zusammenbau
Assemblage
Montaje
安装**

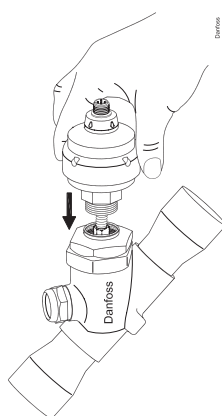
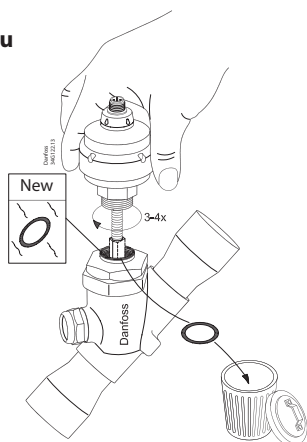

50 Nm / 36 ft-lbf (30°)

27 mm / 1 1/16 in.

ETS 250 and 500P: 41 mm / 1.61 in.
ETS 400 and 800P: 46 mm / 1.81 in.

**Connection
Anschluss
Raccordement
Conexión
链接**

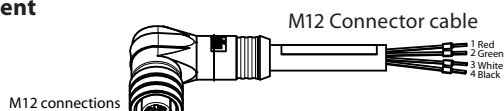

Electrical check
of stepper
motor and wiring.
Coil I = 52 Ω
Coil II = 52 Ω



Warning! / Achtung! / Attention! / Advertencia! / 警告

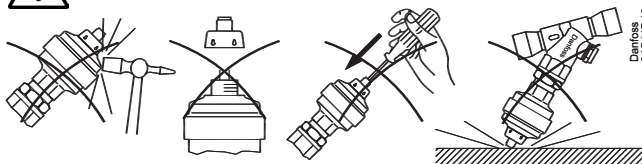

- Do not connect directly to AC/DC power source. Connect valve to appropriate controller/driver only. Do not operate valve while assembling or disassembling.
- Bitte den ETS nicht direkt mit einer Spannungsquelle (Gleich- oder Wechselstrom) verbinden. Schließen Sie das Ventil nur an geeignete Regler/Steuergeräte an. Ventil bitte nicht in zerlegtem Zustand ansteuern.
- Ne pas raccorder directement le moteur à une alimentation AC / DC. Raccorder la vanne au régulateur approprié. Ne pas actionner la vanne pendant le montage ou le démontage.
- No aplicar tensión directamente a la válvula. Conectar la válvula a un controlador/driver adecuado. No haga funcionar la válvula durante el montaje o desmontaje.
- 请仅将阀门连接于合适的控制器/控制器，勿直接与交流或直流电源连接。在安装和拆卸阀门时请勿操作电子膨胀阀。