

Data Sheet

Evaporator Controller

EKE 400

ADAP-KOOL® Refrigeration Control System



Introduction

Application

For industrial refrigeration applications the Danfoss EKE 400 can control the operation of the valves and the fans for evaporators to achieve optimal cooling mode and defrost sequence for an efficient, safe and trouble-free operation of the evaporators, complying with IAR¹ safety recommendations for hot gas defrost

The EKE 400 controller is a dedicated controller for evaporators typically used in industrial refrigeration applications. EKE 400 will be able to manage the complete operation in cooling and defrost mode.

This means:

- Controls operation of the valves and the fans for each evaporator
- Controlling and optimizing defrost sequence and performance
- Applicable for defrosting flooded evaporators, including Ammonia and CO₂
- Supports various defrost methods: Hot gas defrost by pressure control or liquid drain, water/brine defrost, and electrical defrost.
- EKE 400 is using industry terminology in both the HMI² interface and associated literature. (Wet return line, Liquid feed line etc.)

EKE 400 is available both with and without HMI. The HMI contains a graphical display and a six push bottoms to operate and navigate through the menu system. A menu wizard will filter out irrelevant parameters and minimize time at commissioning the EKE 400

As EKE 400 is a dedicated controller for industrial refrigeration it will have full support of Danfoss industrial refrigeration valves³:

- ICF valve station
- ICM motorized valve
- ICS servo valve with constant pressure control pilots like CVP
- OFV overflow valve
- ICLX 2-step gas powered solenoid valve
- ICSH dual position solenoid valve
- ICFD Defrost module
- Various solenoid valves; EVRA, EVRAT, EVRS, EVRST, ICS with EVM, ICF with ICFE



¹ International Institute of Ammonia Refrigeration

² Human Machine Interface (HMI) is the interface between the EKE 400 controller and the user.

³ Competitors valves may be used with EKE 400.

Product Features

- Approved and qualified by Danfoss for refrigeration applications
- One product covering multiple valve configurations
- HMI includes wizard for easy setup
- Multiple EKE 400 can be interconnected for signal sharing via integrated CANBUS. (defrost coordination, temperature sharing etc.)
- Easy to connect to third party equipment like PLC via integrated MODBUS
- EKE 400 is available without HMI to save cost
- One remote HMI can interface multiple EKE 400
- One EKE 400 cover both 24 V AC and 24 V DC
- One EKE 400 cover wide voltage and frequency range; 85 – 265 V AC, 50/60 Hz.
- Flexible Analog input. Cover both Pt-1000/NTC temperature sensor and 4-20 mA/1-5 V Pressure transmitter
- 2 Digital output out of 8 Digital output is solid state for PWM⁴ (puls) valves
- EKE 400 with HMI includes multilanguage support (English, Chinese, Portuguese, Spanish)
- International units supported. Metric and Imperial
- HMI will during setup, filter out irrelevant parameters or conversely, show parameters that are relevant based on earlier selection.

Product Function Features

- Approved for Media temperature/DX⁵ upgrade
- Defrost
 - Support of Multiple Defrost methods
 - Hot Gas defrost by pressure
 - Hot Gas defrost by liquid drain
 - Defrost by water or brine
 - Individual defrost schedules by single weekdays, Saturdays and Sundays
- Defrost start
 - Defrost start by PLC via MODBUS or Digital Input
 - Defrost start by time interval (time since last defrost start)
 - Defrost start according to accumulated cooling time
 - Defrost start via defrost schedules and Real Time Clock (RTC)
 - Forced manual defrost via HMI or by PLC via MODBUS
- Defrost stop
 - Defrost stop on time duration
 - Defrost stop on temperature
- Separate Drip tray control (separate from main Hot Gas valve)
- Emergency cooling - failsafe operation
- Safe startup after power failure
- Product temperature alarm option

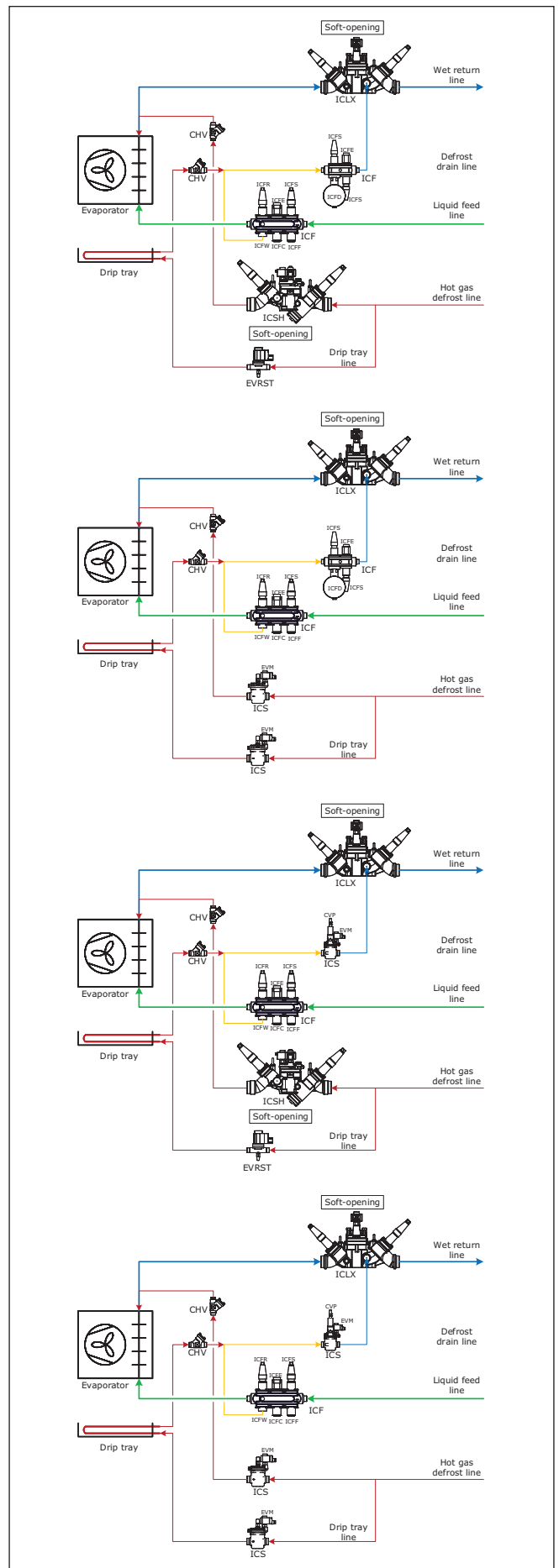

⁴ Pulse Width Modulating valves like Danfoss type AKV or AKVA
⁵ Contact your local Danfoss representative

Basic operation

Configuration and daily operation of EKE 400 is done via the built-in HMI or via a remote connected HMI. The display supports multiple languages and engineering units.

StatusScreens

Get an overview of how the system is running in the status screens. Use the LEFT / RIGHT buttons to view the status screens.

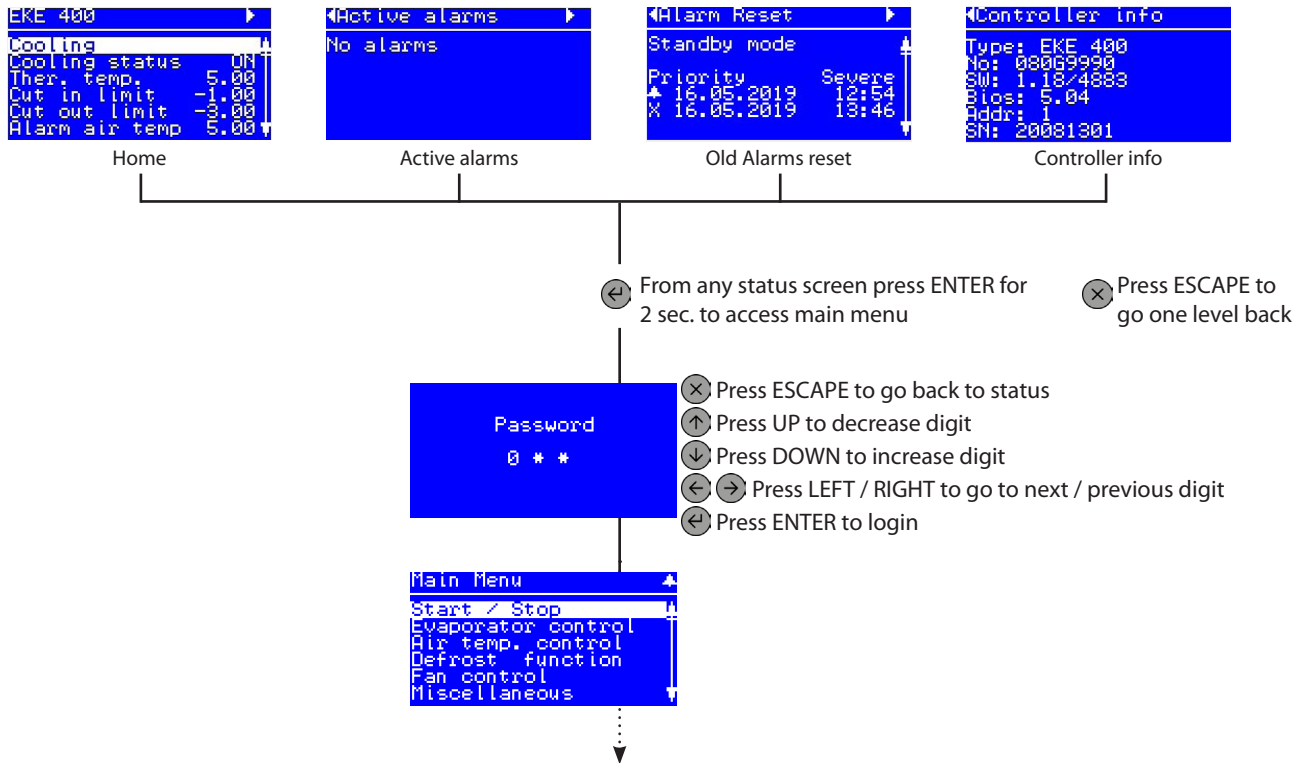

Password

See EKE 400 Wizard, Parameterlist, for further details further details on Password levels and user rights

	Password level 0	Level 0 will only allow to see the screens: "Status screen 1", "Active alarms", "Alarm Reset" and "Controller info"
G07	Password level 1	Level 1 will give access to see all parameters and sub menus, but no settings can be changed.
G08	Password level 2	Enter password for level 2 access. Level 1 will give access to see all parameters and sub menus. Some settings can be changed.
G09	Password level 3	Enter password for level 3 access. Level 1 will give access to see all parameters and sub menus. All settings can be changed.

If the I/O configuration can not be met, after the Wizard is completed, a warning will be displayed

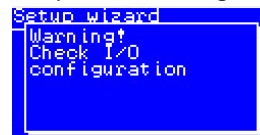

Go to IO configuration or IO status and go through Digital output/input and Analog output/input

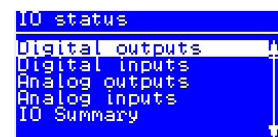
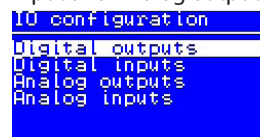

Identify the IO with and exclamation mark "!" and reconfigure it.

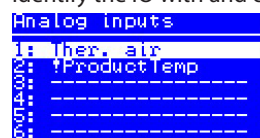

Setup overview

There are two ways in which the controller can be set up.

- Wizard
 - Here you will be led through a series of selected parameters that are commonly needed to be configured at every start up. This will also mean faster setup for many applications.
 - Please observe, that some parameters not included in the Wizard may still need to be configured. this must then be done from the complete Parameter list
- Parameter list
 - Here a complete list of all parameters can be found

Start screen upon delivery

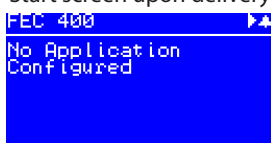

Hold "Enter" ↵ down for 2 seconds to come to password entry



The default password upon delivery is 300. Use the arrow keys to set the password. End by pressing "Enter" ↵

Operating principles

1. Select position using arrow keys
2. Select using "Enter" ↵
3. Use the "X" to return

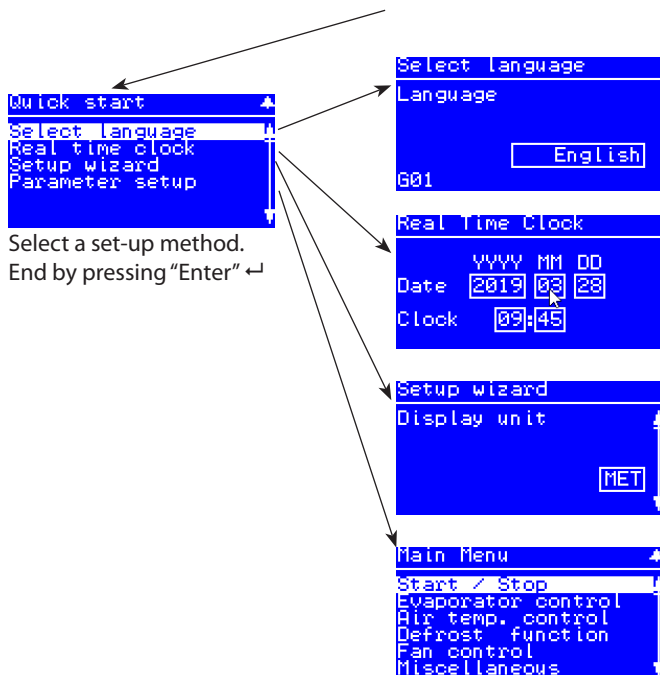
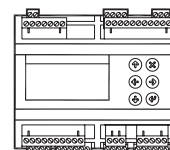

EKE 400 Wizard

Label ID	Parameter name	Description and selection options	Min.	Max	Factory setting
P01	Display unit	Display unit 0:MET: Metric units - Celsius (°C) and Kelvin (°K) 1:IMP: Imperial units - Fahrenheit (°F) and Rankine (°R)	0	1	0=MET
R01	Evap. ctrl mode	Evaporator control mode: -1:None: 0:Flood. evap. On/Off"	-1	0	0=Flood. evap. On/Off;
D1A	Defrost method	Select the defrost method 0:No defrost: No defrost function 1:Hot gas: Defrost done by Hot gas 2:Electrical or water"	0	1	1=Hot gas
R02	Liq. feed line valve	Select type of valves in Liquid feed line 1:Solenoid (ICFE): ON/OFF Solenoid ICF 20 Valve station 2:Solenoid (ICS): ON/OFF Solenoid ICS with EVM pilot 3:Solenoid (ICM): Motorized ICM, as slow opening/closing ON/OFF valve. Occupy 1 DO	1	3	1=Solenoid (ICFE)
D3A	Wet return line val.	Select type of valves in Wet return line 0: No Valve 1: Soft (ICS+EVRST): Dual position individual solenoid valves. Occupy 2 DO 2: Soft (ICSH): Dual position solenoid valve. Occupy 2 DO 3: Soft (ICLX): 2-step gas powered solenoid valve. Occupy 1 DO 4: Solenoid (ICS):ON/OFF Solenoid ICS with EVM pilot 5: Solenoid (ICM):Motorized ICM, as slow opening/closing ON/OFF valve. Occupy 1 DO 6: Slow (ICM): Motorized ICM, as slow opening/closing modulating valve. Occupy 1 AO	0	1	Soft (ICLX)
D2A	Hot gas line valve	Select type of valves in Hot gas defrost line 0: No Valve: 1: Soft (ICS+EVRST): Dual position individual solenoid valves. Occupy 2 DO 2: Soft (ICSH): Dual position solenoid valve. Occupy 2 DO 3: Solenoid (ICFE): ON/OFF Solenoid ICF 20 Valve station 4: Solenoid (ICS):ON/OFF Solenoid ICS with EVM pilot 5: Solenoid (ICM):Motorized ICM, as slow opening/closing ON/OFF valve. Occupy 1 DO 6: Slow (ICM): Motorized ICM, as slow opening/closing modulating valve. Occupy 1 AO	0	6	2=Soft (ICSH)
D1B	HG Drain valve	Select type of valves in defrost drain line 0:Pressure (ICS+CVP): Pressure control valve during hot gas defrost. CVP pilot have ajustable pressure setting 1: Pressure (OFV): Pressure control valve during hot gas defrost. OFV have ajustable pressure setting 2: Liquid drain (ICFD): Liquid drain during defrost	0	2	1=Pressure (ICS+CVP)
D4A	Drain solenoid?	Decide if drain solenoid in defrost drain line is installed No Yes	0=No	1=Yes	1=Yes
D4B	Quick Drain?	Decide if drain valve is installed to drain liquid quikly out before hot gas enter evaporator No Yes	0=No	1=Yes	0=No
T04	Ther. setpoint	Thermostat set point temperature	-50.0	50.0	2.0
T05	Ther. neutral zone	Thermostat neutral zone Start/Stop limit around the "T03 Ther. Setpoint"	0.1	20.0	2.0
B02	High alarm limit	High alarm limit High alarm for the room temperature alarm function. Entered as absolute value	-50.0	50.0	6.0

Label ID	Parameter name	Description and selection options	Min.	Max	Factory setting
B03	Low alarm limit	Low alarm limit Low alarm for the room temperature alarm function. Entered as absolute value	-50.0	50.0	-30.0
B04	Alarm delay	Alarm delay Alarm delay time during normal control used for both high- and low temperature alarms	0	240	120
D11	Def. time interval	Defrost start by time interval Fail safe function if another configured defrost start, has failed. A defrost will be started when the interval counter (real time) exceeds the 'Defrost time interval' setting. The interval counter is start counting from zero when the defrost is started. The interval counter will be reset at every defrost start. The interval counter shall be in standby (not counting) at "Main switch is OFF". Can be seen in Status Screen 1. If "D11,Def. time interval" is 0 (zero) the function is disabled	0	240	0
D12	Def. start acc. cool time	Defrost start by accumulated cooling time Can also be used as a fail safe function if another configured defrost start, has failed. A defrost will be started when the accumulated cooling time exceeds "D12,Def. start acc. cool time" setting. The accumulated cooling time will be reset at every defrost start.	0	240	0
D13	Time staggering	Time staggered defrost Defrost will only be staggered after: - After power cut. - Start according to "D11,Def. time interval" - This means Start defrost after ["D11,Def. time interval" + "D13,Time staggering"] - Start according to "D12,Def. start acc. cool time" - This means Start defrost after ["D12,Def. start acc. cool time" + "D13,Time staggering"] Successive defrosts will be started when the time interval Defrost time interval or accumulated cooling time has elapsed"	0	240	0
D14	Def. start by DI	Defrost start by DI Option to start defrost via DI. Typical external signal from PLC or a push bottom. If function is enabled, a defrost is started when the DI changes from OFF to ON. Successive change of the DI during the defrost period are ignored. No: Function disable Yes: Function enabled"	0=No	1=Yes	0=No
D15	Def. start schedule	Defrost start schedule Option to run defrost according to local time schedules in EKE 400. Three schedules possible (weekdays, Saturdays and Sunday) with 6 defrost start time each No: Function disable Yes:Function enabled"	0=No	1=Yes	0=No
D40	Defrost stop method	Defrost stop method Select method for stop of defrost 1: Stop on time: When the time delay "D58,Max defrost time" expires, the defrost is terminated 2: Stop on temp: When the defrost sensor temperature becomes greater than the set point "D43,Def. stop temp. limit", then the defrost is terminated. If the defrost time exceed "D58,Max defrost time", then the alarm 'Max defrost time' is send and the defrost is terminated. In case of sensor error, and the time 'Max defrost time' expires, the alarm 'Max defrost time' is send and the defrost is terminated. The alarm will automatically be reset after 5 minutes. To assign defrost sensor temperature, go to I/O configuration in Main menu and select an available AI"	1	2	1=Stop on time
D50	Pump down delay	Pump down delay Draining the evaporator before defrosting. Always active The pump down state is used to empty the evaporator for liquid. See Fig. 1 - Defrost sequence	1	30	10

Label ID	Parameter name	Description and selection options	Min.	Max	Factory setting
D51	HG open delay	Hot Gas open delay Time delay in minutes before opening the hot gas valve (delay for valve in the wet return line to close) See Fig. 1 - Defrost sequence	1	10	5
D53	HG soft time	Hot gas soft time Time between step 1 and step 2 for opening the hot gas valve (2 DO used) See Fig. 1 - Defrost sequence	1	30	3
D58	Max defrost time	Max defrost time Max. allowed defrost duration in minutes	1	120	30
D59	Drip off time	Drip off time Allow water on the evaporator to drip off. See Fig. 1 - Defrost sequence	1	15	5
D61	WR soft time	Wet return soft time Time between step 1 and step 2 for opening the wet return valve ("Soft (ICS+EVRST)" or "Soft (ICSH) See Fig. 1 - Defrost sequence	1	30	2
D6A	WR main time	Wet return main time After defrost and wet return valve has opened (main), enter delay before valve in liquid line to open. See Fig. 1 - Defrost sequence	1	30	2
D65	Fan start delay	Fan start delay The fan will be started when the time has elapsed. See Fig. 1 - Defrost sequence	0	30	2
P03	Main switch via DI	Mainswitch via DI Release EKE 400 for operation or force EKE 400 out of operation via external equipment (e.g. PLC), via DI OFF: EKE 400 is forced out of operation. Observe if "M01,Main switch" is ON, this parameter will also when OFF, force EKE 400 out of operation ON: EKE 400 released for operation. Observe if "M01,Main switch" is ON, this parameter must also be ON, to release EKE 400 for operation	0=No	1=Yes	0=No

Parameter list

Observe that many of the individual parameters listed below, will only be visible, if other parameters have been set. Hereby irrelevant parameters are filtered out, during setup of EKE 400.

Label ID	Parameter name	Description and selection options	Min.	Max	Factory Setting	Unit	Decimals	Locked by Main switch Yes/No	See Label ID, G07,G08,G09			All Modbus parameters is type: WORD (signed 16 bit)		
									Read	Pass-word level to change/write	Modbus address	Read only (RO) / Read Write (RW)	Persistent Yes/No	Modbus function
Start / stop														
M01	Main switch	Release the controller for operation or force EKE 400 out of operation OFF: the controller is forced out of operation. Observe if "M02, Ext. Main switch" is ON, this DI will also when OFF, forced the controller out of operation ON: the controller released for operation. Observe if "M02, Ext. Main switch" is ON, this DI must also be ON to release the controller for operation	0=OFF	1=ON	0=OFF		0	No	Pass-word level 1,2,3	2	3001	RW	Yes	3, 4 & 16
M02	Ext. Main switch	Status of the external main switch (DI)	0=OFF	1=ON	-		0	Yes	Pass-word level 1,2,3	Can never be changed	3002	RO	Yes	3
Evaporator control														
R01	Evap. ctrl mode	Evaporator control mode: -1:None: 0:Flood. evap. ON/OFF	-1	0	0=Flood. evap. On/Off;		0	Yes	Pass-word level 1,2,3	3	3020	RW	Yes	3, 4 & 16
R02	Liq. feed line valve	Select type of valves in Liquid feed line. 1: Solenoid (ICFE): ON/OFF Solenoid ICF 20 Valve station 2: Solenoid (ICS): ON/OFF Solenoid ICS with EVM pilot 3: Solenoid (ICM): Motorized ICM, as slow opening/closing ON/OFF valve. Occupy 1 DO	1	3	1=So-lenoid (ICFE)		0	Yes	Pass-word level 1,2,3	3	3021	RW	Yes	3, 4 & 16
R05	Cool On/Off by DI	Cooling demand from external equipment (e.g. PLC) to EKE 400, via DI	0=No	1=Yes	0=No		0	Yes	Pass-word level 1,2,3	3	3024	RW	Yes	3, 4 & 16
R06	Forced closing	Forced stop cooling via MODBUS (e.g. PLC) or local from EKE 400 If a PLC controls cooling ON/OFF, "R06,Forced closing" can be used to stop cooling. OFF: Function disabled ON: Forced stop cooling, regardless of cooling request. Observe. Will automatically after 15 min go back to OFF.	0=OFF	1=ON	0=OFF		0	No	Pass-word level 1,2,3	2	3025	RW	No	3, 4 & 16
R07	Forced cooling	Forced cooling via MODBUS (e.g. PLC) or local from EKE 400 The function is typical used to secure enough hot gas to defrost other evaporators If a PLC controls cooling ON/OFF, "R07,Forced cooling" can be used to start cooling. OFF: Function disabled ON: Forced cooling, regardless of cooling request. Observe. Will automatically after 15 min go back to OFF.	0=OFF	1=ON	0=OFF		0	No	Pass-word level 1,2,3	2	3026	RW	No	3, 4 & 16
R08	Forced close by DI	Forced stop cooling via external equipment (e.g. PLC) to EKE 400, via DI If a PLC controls cooling ON/OFF, DI can be used to stop cooling. No: Function disabled Yes:Forced stop cooling, regardless of cooling request. To assign DI, go to I/O configuration in Main menu and select an available DI	0=No	1=Yes	0=No		0	Yes	Pass-word level 1,2,3	3	3027	RW	Yes	3, 4 & 16

Label ID	Parameter name	Description and selection options	Min.	Max	Factory Setting	Unit	Decimals	Locked by Main switch Yes/No	Read	Password level to change/write	Modbus address	Read only (RO) / Read Write (RW)	Persistent Yes/No	Modbus function
R09	Forced cool by DI	Forced cooling via external equipment (e.g. PLC) to EKE 400, via DI If a PLC controls cooling ON/OFF, DI can be used to start cooling. No: Function disabled Yes: Forced cooling, regardless of cooling request. To assign DI, go to I/O configuration in Main menu and select an available DI	0=No	1=Yes	0=No		0	Yes	Password level 1,2,3	3	3028	RW	Yes	3, 4 & 16
Air temperature control \ Thermostat function														
T01	Ther. mode	Select thermostat control mode. 0:None: None thermostat function (continuously cooling if not overruled) 1:Individual ON/OFF: Control according to local temperature sensor connected to EKE 400 Common ON/OFF: More EKE 400 are connected via the CAN bus and will start- and stop cooling at the same time. The Thermostat air temp. is broadcasted between controllers configured as "T01,Ther. mode" = "Common ON/OFF" The Master EKE 400 calculates the "Ther. temp." defined in "T03,Ctrl temp. method" The Master EKE 400 will secure that all remaining EKE 400 start and stop cooling synchronously. Master EKE will always linked the EKE with the lowest value entered in "G11,Modbus address"	0	1	1=Individual ON/OFF		0	No	Password level 1,2,3	3	3037	RW	Yes	3, 4 & 16
T02	No. of ther. sensor	Number of temperature sensors connected to EKE 400. It is possible to connect up to 3 room thermostat sensors to the same controller. Typically, only one thermostat sensor is connected, but sometimes more sensors are connected to avoid "hot spots" in a room. 0: No thermostat sensor connected 1: One thermostat sensor connected 2: Two thermostat sensors connected 3: Three thermostat sensors connected	0	3	1		0	Yes	Password level 1,2,3	2	3038	RW	Yes	3, 4 & 16
T03	Ctrl temp. method	Control method The control method shall be selected if common thermostat is selected or if more thermostat sensors are connected to EKE 400. The temperatures used of thermostat is selected by setting of "T03, Ctrl temp. method": 0:Ctrl highest temp: 1:Ctrl average temp.:	0	1	1=Ctrl highest temp		0	No	Password level 1,2,3	2	3039	RW	Yes	3, 4 & 16
T04	Ther. setpoint	Thermostat set point temperature	-50.0	50.0	2.0	°C / °F	1	No	Password level 1,2,3	2	3040	RW	Yes	3, 4 & 16
T05	Ther. neutral zone	Thermostat neutral zone. Start/Stop limit around the "T03 Ther. Setpoint"	0.1	20.0	2.0	K	1	No	Password level 1,2,3	2	3041	RW	Yes	3, 4 & 16
T06	Day/night control	Day/Night control Function that allow to add an offset value to "T03 Ther. Setpoint". No: Function disabled Yes: Function enabled. Night status visible in Status Screen 1. See "T08,Night offset"	0=No	1=Yes	0=No		0	No	Password level 1,2,3	3	3042	RW	Yes	3, 4 & 16
T07	Night operation	Night Operation Enable function to offset "T04,Ther. Setpoint", typical via MODBUS (e.g. PLC) No: Day operation : No offset - not active Yes: Night operation. If "T06, Day/night control" is Yes, then add "T08, Night offset" to "T04,Ther. Setpoint"	0=No	1=Yes	0=No		0	No	Password level 1,2,3	2	3043	RW	Yes	3, 4 & 16

Label ID	Parameter name	Description and selection options	Min.	Max	Factory Setting	Unit	Decimals	Locked by Main switch Yes/No	Read	Password level to change/write	Modbus address	Read only (RO) / Read Write (RW)	Persistent Yes/No	Modbus function
T08	Night offset	Night offset Enter the Offset value to thermostat set point temperature. See "T07, Night operation"	-20.0	20.0	-2.0	K	1	No	Pass-word level 1,2,3	2	3044	RW	Yes	3, 4 & 16
T09	Cool. status DO	Cooling status DO Select status if Evapartor is in cooling mode and read out to Digital OutputActual cooling status to be read on a DO. No:Function Disabled Yes:Function Enabled. If Evapartor is in cooling mode then DO is ON, otherwise DO is OFF. To assign DO, go to I/O configuration in Main menu and select an available DO.	0=No	1=Yes	0=No		0	Yes	Pass-word level 1,2,3	3	3045	RW	Yes	3, 4 & 16
Air temperature control \ Air temp. Alarm														
B01	Air temp. alarm	Select which temperature sensor shall be connected to temperature alarms. 0:None: No temperature alarms active 1:Seperate sensor: A separate sensor for the alarm function. 2:Thermostat temp: The Thermostat temperature sensot is used for the alarm function.	0	2	2=Thermostat temp.		0	Yes	Pass-word level 1,2,3	3	3046	RW	Yes	3, 4 & 16
B02	High alarm limit	High alarm limit High alarm for the room temperature alarm function. Entered as absolute value	-50.0	50.0	6.0	°C	1	No	Pass-word level 1,2,3	2	3047	RW	Yes	3, 4 & 16
B03	Low alarm limit	Low alarm limit Low alarm for the room temperature alarm function. Entered as absolute value	-50.0	50.0	-30.0	°C	1	No	Pass-word level 1,2,3	2	3048	RW	Yes	3, 4 & 16
B04	Alarm delay	Alarm delay Alarm delay time during normal control used for both high- and low temperature alarms	0	240	120	min	0	No	Pass-word level 1,2,3	2	3049	RW	Yes	3, 4 & 16
Air temperature control \ Product temperature alarm function														
B05	Product alarm function	Product temperature alarm The air temperature is not always representative for the temperature of the products. A product sensor to measure the actual temperature in between the products. This sensor is used for monitoring purposes only including alarm handling. No: Function disabled; Yes: Function enabled. Product alarms active. "Product temp." can be seen in Status Screen 1.	0=No	1=Yes	0=No		0	Yes	Pass-word level 1,2,3	3	3050	RW	Yes	3, 4 & 16
B06	Prod. high alarm limit	Product High alarm High alarm limit for the product temperature alarm function. Entered as absolute value	-50.0	50.0	6.0	°C	1	No	Pass-word level 1,2,3	2	3051	RW	Yes	3, 4 & 16
B07	Prod. low alarm limit	Product Low alarm Low alarm limit for the product temperature	-50.0	50.0	-30.0	°C	1	No	Pass-word level 1,2,3	2	3052	RW	Yes	3, 4 & 16
B08	Prod. alarm delay	Product Alarm delay Alarm delay time used for both high- and low product temperature alarm function	0	240	120	min	0	No	Pass-word level 1,2,3	2	3053	RW	Yes	3, 4 & 16
Defrost function \ Defrost method														
D1A	Defrost method	Select the defrost method. 0:No defrost: No defrost function 1:Hot gas: Defrost done by Hot gas 2:Electrical or water	0	1	1=Hot gas		0	Yes	Pass-word level 1,2,3	3	3244	RW	Yes	3, 4 & 16

Label ID	Parameter name	Description and selection options	Min.	Max	Factory Setting	Unit	Decimals	Locked by Main switch Yes/No	Read	Password level to change/write	Modbus address	Read only (RO) / Read Write (RW)	Persistent Yes/No	Modbus function
D1B	HG Drain valve	Select type of valves in defrost drain line 0: Pressure (ICS+CVP): Pressure control valve during hot gas defrost. CVP pilot have ajustable pressure setting 1: Pressure (OFV): Pressure control valve during hot gas defrost. OFV have ajustable pressure setting 2: Liquid drain (ICFD): Liquid drain during defrost	0	2	1= Pressure (ICS+ CVP)		0	Yes	Pass- word level 1,2,3	3	3245	RW	Yes	3, 4 & 16
D2A	Hot gas line valve	Select type of valves in Hot gas defrost line 0: No Valve: 1: Soft (ICS+EVRST): Dual position individual solenoid valves. Occupy 2 DO 2: Soft (ICSH): Dual position solenoid valve. Occupy 2 DO 3: Solenoid (ICFE): ON/OFF Solenoid ICF 20 Valve station 4: Solenoid (ICS):ON/OFF Solenoid ICS with EVM pilot 5: Solenoid (ICM):Motorized ICM, as slow opening/closing ON/OF valve. Occupy 1 DO 6: Slow (ICM): Motorized ICM, as slow opening/ closing modulating valve. Occupy 1 AO	0	6	2=Soft (ICSH)		0	Yes	Pass- word level 1,2,3	3	3247	RW	Yes	3, 4 & 16
D2B	HG Drip tray DO	Select possible DO hot gas valve for drip tray line No: No Drip tray valve/function Yes: Drip tray valve and function active	0=No	1=Yes	0=No		0	Yes	Pass- word level 1,2,3	3	3255	RW	Yes	3, 4 & 16
D3A	Wet return line val.	Select type of valves in Wet return line. 0: No Valve 1: Soft (ICS+EVRST): Dual position individual solenoid valves. Occupy 2 DO 2: Soft (ICSH): Dual position solenoid valve. Occupy 2 DO 3: Soft (ICLX): 2-step gas powered solenoid valve. Occupy 1 DO 4: Solenoid (ICS):ON/OFF Solenoid ICS with EVM pilot 5: Solenoid (ICM):Motorized ICM, as slow opening/closing ON/OF valve. Occupy 1 DO 6: Slow (ICM): Motorized ICM, as slow opening/ closing modulating valve. Occupy 1 AO	0	1	Soft (ICLX)		0	Yes	Pass- word level 1,2,3	3	3253	RW	Yes	3, 4 & 16
D3B	WR at Cool. stopped	Wet return at cooling stopped Select the close/open of Wet return valve during cooling stopped. Closed: Wet return valve closed during Cooling OBSERVE - assess risk of trapped liquid when Wet return valve is closed during Cooling stopped Open: Wet return valve open during Cooling	0=closed	1= Open	1=Open		0	Yes	Pass- word level 1,2,3	3	3323	RW	Yes	3, 4 & 16
D4A	Drain solenoid?	Decide if drain solenoid in defrost drain line is installed No Yes	0=No	1=Yes	1=Yes		0	Yes	Pass- word level 1,2,3	3	3252	RW	Yes	3, 4 & 16
D4B	Quick Drain?	Decide if drain valve is installed to drain liquid quickly out before hot gas enter evaporator No Yes	0=No	1=Yes	0=No		0	Yes	Pass- word level 1,2,3	3	3254	RW	Yes	3, 4 & 16

Label ID	Parameter name	Description and selection options	Min.	Max	Factory Setting	Unit	Decimals	Locked by Main switch Yes/No	Read	Password level to change/write	Modbus address	Read only (RO) / Read Write (RW)	Persistent Yes/No	Modbus function
D05	Cool at HG defrost	<p>Cool at Hot Gas defrost Typical when no PLC connected to coordinate defrost If defrost start is coordinated locally by EKE 400, it is possible to configure if EKE 400 shall go into forced cooling, when another EKE 400 in the same group is defrosting. Each EKE 400 in a group will broadcast the signal "Defrost sequence status" over CAN bus.</p> <p>No: Function disable Yes: Function enabled</p>	0=No	1=Yes	0=No		0	Yes	Pass-word level 1,2,3	3	3082	RW	Yes	3, 4 & 16
D06	Defrost allowed	<p>Defrost allowed Typical with PLC connected via MODBUS, but defrost is handled by EKE 400. PLC to allow defrost to take place, typical only if Hot gas is available.</p> <p>No: Defrost not allowed from PLC (no Hot gas available) Yes: Defrost allowed from PLC (Hot gas is available)</p>	0=No	1=Yes	1=Yes		0	No	Pass-word level 1,2,3	2	3083	RW	Yes	3, 4 & 16
D07	Defrost allowed via DI	<p>Defrost allowed via DI Typical with PLC connected via DI, but defrost is handled by EKE 400. PLC to allow defrost to take place, typical only if Hot gas is available.</p> <p>No: Function disable Yes: Function enabled. OBSERVE require that "D07, Defrost allowed"="Yes" To assign DI, go to I/O configuration in Main menu and select an available DI. Set this DI to "Defrost allowed via DI"</p>	0=No	1=Yes	0=No		0	Yes	Pass-word level 1,2,3	3	3084	RW	Yes	3, 4 & 16
D08	Def. seq. status on DO	<p>Def. seq. status on DO Select if an DO shall be synchronized with defrost seq. status (ON/OFF). The DO is set ON at defrost start and is set OFF when the complete defrost sequence is completed.</p> <p>No: Disabled Yes: Enabled To assign DO, go to I/O configuration in Main menu and select an available DO. Set this DO to "Def. seq. status on DO" DO=OFF: Defrost completed DO=ON: Defrost is underway</p>	0=No	1=Yes	0=No		0	Yes	Pass-word level 1,2,3	3	3085	RW	Yes	3, 4 & 16
D09	Water valve?	<p>Decide if Water valve is used This function adds control of a valve that enables water spray on the evaporator during hot gas defrosting. Helps to loosen ice on evaporator during defrost, by means of water (spay)</p> <p>No: Disabled Yes: Function enabled To assign DO, go to I/O configuration in Main menu and select an available DO</p> <p>The water valve opens when the following two criteria are meet: The hot gas main valve is ON and the "D67, Water valve delay" limited has expired. When the Water valve is opened a timer starts defined in "D68, Water valve time". The Water valve closes when the timer reaches "D68, Water valve time" or when entering "D59, Drip off time". (See Fig. 1 - Defrost sequence)</p>	0=No	1=Yes	0=No		0	Yes	Pass-word level 1,2,3	3	3325	RW	Yes	3, 4 & 16
Defrost function \ Defrost start methods														
D10	Man. def. start	<p>Manual defrost start A manual defrost start can be done (Forced defrost) - Can also be used from a PLC connected via MODBUS</p> <p>OFF: No forced defrost ON: Forced manual defrost.</p>	0=OFF	1=ON	0=OFF		0	No	Pass-word level 1,2,3	2	3054	RW	No	3, 4 & 16

Label ID	Parameter name	Description and selection options	Min.	Max	Factory Setting	Unit	Decimals	Locked by Main switch Yes/No	Read	Password level to change/write	Modbus address	Read only (RO) / Read Write (RW)	Persistent Yes/No	Modbus function
D11	Def. time interval	<p>Defrost start by time interval</p> <p>Fail safe function if another configured defrost start, has failed.</p> <p>A defrost will be started when the interval counter (real time) exceeds the 'Defrost time interval' setting.</p> <p>The interval counter is start counting from zero when the defrost is started.</p> <p>The interval counter will be reset at every defrost start.</p> <p>The interval counter shall be in standby (not counting) at "Main switch is OFF". Can be seen in Status Screen 1.</p> <p>If "D11,Def. time interval" is 0 (zero) the function is disabled"</p>	0	240	0	hours	0	No	Password level 1,2,3	2	3075	RW	Yes	3, 4 & 16
D12	Def. start acc. cool time	<p>Defrost start by accumulated cooling time.</p> <p>Can also be used as a fail safe function if another configured defrost start, has failed.</p> <p>A defrost will be started when the accumulated cooling time exceeds "D12,Def. start acc. cool time" setting.</p> <p>The accumulated cooling time will be reset at every defrost start.</p>	0	240	0	hours	0	No	Password level 1,2,3	2	3076	RW	Yes	3, 4 & 16
D13	Time staggering	<p>Time staggered defrost.</p> <p>Defrost will only be staggered after:</p> <ul style="list-style-type: none"> - After power cut. - Start according to "D11,Def. time interval" - This means Start defrost after ["D11,Def. time interval" + "D13,Time staggering"] - Start according to "D12,Def. start acc. cool time" - This means Start defrost after ["D12,Def. start acc. cool time" + "D13,Time staggering"] <p>Successive defrosts will be started when the time interval Defrost time interval or accumulated cooling time has elapsed"</p>	0	240	0	min	0	No	Password level 1,2,3	2	3077	RW	Yes	3, 4 & 16
D14	Def. start by DI	<p>Defrost start by DI</p> <p>Option to start defrost via DI. Typical external signal from PLC or a push bottom.</p> <p>If function is enabled, a defrost is started when the DI changes from OFF to ON. Successive change of the DI during the defrost period are ignored.</p> <p>No: Function disable Yes: Function enabled</p>	0=No	1=Yes	0=No		0	Yes	Password level 1,2,3	3	3055	RW	Yes	3, 4 & 16
D15	Def. start schedule	<p>Defrost start schedule</p> <p>Option to run defrost according to local time schedules in EKE 400. Three schedules possible (weekdays, Saturdays and Sunday) with 6 defrost start time each</p> <p>No: Function disable Yes: Function enabled</p>	0=No	1=Yes	0=No		0	No	Password level 1,2,3	3	3056	RW	Yes	3, 4 & 16
DA1	Def. 1 sch.MON-DAY	Defrost start time for MONDAY	0=00:00	1439=23:59	0=00:00		0	No	Password level 1,2,3	2	3277	RW	Yes	3, 4 & 16
DA2	Def. 2 sch.MON-DAY	Defrost start time for MONDAY	0=00:00	1439=23:59	0=00:00		0	No	Password level 1,2,3	2	3278	RW	Yes	3, 4 & 16

Label ID	Parameter name	Description and selection options	Min.	Max	Factory Setting	Unit	Decimals	Locked by Main switch Yes/No	Read	Password level to change/write	Modbus address	Read only (RO) / Read Write (RW)	Persistent Yes/No	Modbus function
DA3	Def. 3 sch.MON-DAY	Defrost start time for MONDAY	0=00:00	1439=23:59	0=00:00		0	No	Password level 1,2,3	2	3279	RW	Yes	3, 4 & 16
DA4	Def. 4 sch.MON-DAY	Defrost start time for MONDAY	0=00:00	1439=23:59	0=00:00		0	No	Password level 1,2,3	2	3280	RW	Yes	3, 4 & 16
DA5	Def. 5 sch.MON-DAY	Defrost start time for MONDAY	0=00:00	1439=23:59	0=00:00		0	No	Password level 1,2,3	2	3281	RW	Yes	3, 4 & 16
DA6	Def. 6 sch.MON-DAY	Defrost start time for MONDAY	0=00:00	1439=23:59	0=00:00		0	No	Password level 1,2,3	2	3282	RW	Yes	3, 4 & 16
DX1	Copy MONDAY to:	Copy MONDAY schedules Copy MONDAY to other day or week days or all days: 0 = MONDAY 1 = TUESDAY 2 = WEDNESDAY 3 = THURSDAY 4 = FRIDAY 5 = SATURDAY 6 = SUNDAY 7 = week days 8 = all days	0	8	0=MON-DAY		0	No	Password level 1,2,3	2	3324	RW	Yes	3, 4 & 16
DB1	Def. 1 sch.TUESDAY	Defrost start time for TUESDAY	0=00:00	1439=23:59	0=00:00		0	No	Password level 1,2,3	2	3283	RW	Yes	3, 4 & 16
DB2	Def. 2 sch.TUESDAY	Defrost start time for TUESDAY	0=00:00	1439=23:59	0=00:00		0	No	Password level 1,2,3	2	3284	RW	Yes	3, 4 & 16
DB3	Def. 3 sch.TUESDAY	Defrost start time for TUESDAY	0=00:00	1439=23:59	0=00:00		0	No	Password level 1,2,3	2	3285	RW	Yes	3, 4 & 16
DB4	Def. 4 sch.TUESDAY	Defrost start time for TUESDAY	0=00:00	1439=23:59	0=00:00		0	No	Password level 1,2,3	2	3286	RW	Yes	3, 4 & 16
DB5	Def. 5 sch.TUESDAY	Defrost start time for TUESDAY	0=00:00	1439=23:59	0=00:00		0	No	Password level 1,2,3	2	3287	RW	Yes	3, 4 & 16
DB6	Def. 6 sch.TUESDAY	Defrost start time for TUESDAY	0=00:00	1439=23:59	0=00:00		0	No	Password level 1,2,3	2	3288	RW	Yes	3, 4 & 16
DC1	Def. 1 sch. WEDNESDAY	Defrost start time for WEDNESDAY	0=00:00	1439=23:59	0=00:00		0	No	Password level 1,2,3	2	3289	RW	Yes	3, 4 & 16
DC2	Def. 2 sch. WEDNESDAY	Defrost start time for WEDNESDAY	0=00:00	1439=23:59	0=00:00		0	No	Password level 1,2,3	2	3290	RW	Yes	3, 4 & 16
DC3	Def. 3 sch. WEDNESDAY	Defrost start time for WEDNESDAY	0=00:00	1439=23:59	0=00:00		0	No	Password level 1,2,3	2	3291	RW	Yes	3, 4 & 16
DC4	Def. 4 sch. WEDNESDAY	Defrost start time for WEDNESDAY	0=00:00	1439=23:59	0=00:00		0	No	Password level 1,2,3	2	3292	RW	Yes	3, 4 & 16

Label ID	Parameter name	Description and selection options	Min.	Max	Factory Setting	Unit	Decimals	Locked by Main switch Yes/No	Read	Password level to change/write	Modbus address	Read only (RO) / Read Write (RW)	Persistent Yes/No	Modbus function
DC5	Def. 5 sch. WEDNESDAY	Defrost start time for WEDNESDAY	0=00:00	1439=23:59	0=00:00		0	No	Password level 1,2,3	2	3293	RW	Yes	3, 4 & 16
DC6	Def. 6 sch. WEDNESDAY	Defrost start time for WEDNESDAY	0=00:00	1439=23:59	0=00:00		0	No	Password level 1,2,3	2	3294	RW	Yes	3, 4 & 16
DD1	Def. 1 sch. THURSDAY	Defrost start time for THURSDAY	0=00:00	1439=23:59	0=00:00		0	No	Password level 1,2,3	2	3295	RW	Yes	3, 4 & 16
DD2	Def. 2 sch. THURSDAY	Defrost start time for THURSDAY	0=00:00	1439=23:59	0=00:00		0	No	Password level 1,2,3	2	3296	RW	Yes	3, 4 & 16
DD3	Def. 3 sch. THURSDAY	Defrost start time for THURSDAY	0=00:00	1439=23:59	0=00:00		0	No	Password level 1,2,3	2	3297	RW	Yes	3, 4 & 16
DD4	Def. 4 sch. THURSDAY	Defrost start time for THURSDAY	0=00:00	1439=23:59	0=00:00		0	No	Password level 1,2,3	2	3298	RW	Yes	3, 4 & 16
DD5	Def. 5 sch. THURSDAY	Defrost start time for THURSDAY	0=00:00	1439=23:59	0=00:00		0	No	Password level 1,2,3	2	3299	RW	Yes	3, 4 & 16
DD6	Def. 6 sch. THURSDAY	Defrost start time for THURSDAY	0=00:00	1439=23:59	0=00:00		0	No	Password level 1,2,3	2	3300	RW	Yes	3, 4 & 16
DE1	Def. 1 sch. FRIDAY	Defrost start time for FRIDAY	0=00:00	1439=23:59	0=00:00		0	No	Password level 1,2,3	2	3301	RW	Yes	3, 4 & 16
DE2	Def. 2 sch. FRIDAY	Defrost start time for FRIDAY	0=00:00	1439=23:59	0=00:00		0	No	Password level 1,2,3	2	3302	RW	Yes	3, 4 & 16
DE3	Def. 3 sch. FRIDAY	Defrost start time for FRIDAY	0=00:00	1439=23:59	0=00:00		0	No	Password level 1,2,3	2	3303	RW	Yes	3, 4 & 16
DE4	Def. 4 sch. FRIDAY	Defrost start time for FRIDAY	0=00:00	1439=23:59	0=00:00		0	No	Password level 1,2,3	2	3304	RW	Yes	3, 4 & 16
DE5	Def. 5 sch. FRIDAY	Defrost start time for FRIDAY	0=00:00	1439=23:59	0=00:00		0	No	Password level 1,2,3	2	3305	RW	Yes	3, 4 & 16
DE6	Def. 6 sch. FRIDAY	Defrost start time for FRIDAY	0=00:00	1439=23:59	0=00:00		0	No	Password level 1,2,3	2	3306	RW	Yes	3, 4 & 16
DF1	Def. 1 sch. SATURDAY	Defrost start time for SATURDAY	0=00:00	1439=23:59	0=00:00		0	No	Password level 1,2,3	2	3307	RW	Yes	3, 4 & 16
DF2	Def. 2 sch. SATURDAY	Defrost start time for SATURDAY	0=00:00	1439=23:59	0=00:00		0	No	Password level 1,2,3	2	3308	RW	Yes	3, 4 & 16
DF3	Def. 3 sch. SATURDAY	Defrost start time for SATURDAY	0=00:00	1439=23:59	0=00:00		0	No	Password level 1,2,3	2	3309	RW	Yes	3, 4 & 16

Label ID	Parameter name	Description and selection options	Min.	Max	Factory Setting	Unit	Decimals	Locked by Main switch Yes/No	Read	Password level to change/write	Modbus address	Read only (RO) / Read Write (RW)	Persistent Yes/No	Modbus function
DF4	Def. 4 sch.SATURDAY	Defrost start time for SATURDAY	0=00:00	1439=23:59	0=00:00		0	No	Password level 1,2,3	2	3310	RW	Yes	3, 4 & 16
DF5	Def. 5 sch.SATURDAY	Defrost start time for SATURDAY	0=00:00	1439=23:59	0=00:00		0	No	Password level 1,2,3	2	3311	RW	Yes	3, 4 & 16
DF6	Def. 6 sch.SATURDAY	Defrost start time for SATURDAY	0=00:00	1439=23:59	0=00:00		0	No	Password level 1,2,3	2	3312	RW	Yes	3, 4 & 16
DG1	Def. 1 sch.SUNDAY	Defrost start time for SUNDAY	0=00:00	1439=23:59	0=00:00		0	No	Password level 1,2,3	2	3313	RW	Yes	3, 4 & 16
DG2	Def. 2 sch.SUNDAY	Defrost start time for SUNDAY	0=00:00	1439=23:59	0=00:00		0	No	Password level 1,2,3	2	3314	RW	Yes	3, 4 & 16
DG3	Def. 3 sch.SUNDAY	Defrost start time for SUNDAY	0=00:00	1439=23:59	0=00:00		0	No	Password level 1,2,3	2	3315	RW	Yes	3, 4 & 16
DG4	Def. 4 sch.SUNDAY	Defrost start time for SUNDAY	0=00:00	1439=23:59	0=00:00		0	No	Password level 1,2,3	2	3316	RW	Yes	3, 4 & 16
DG5	Def. 5 sch.SUNDAY	Defrost start time for SUNDAY	0=00:00	1439=23:59	0=00:00		0	No	Password level 1,2,3	2	3317	RW	Yes	3, 4 & 16
DG6	Def. 6 sch.SUNDAY	Defrost start time for SUNDAY	0=00:00	1439=23:59	0=00:00		0	No	Password level 1,2,3	2	3318	RW	Yes	3, 4 & 16
Defrost function \ Defrost stop methods														
D40	Defrost stop method	Defrost stop method Select method for stop of defrost 1:Stop on time: When the time delay "D58,Max defrost time" expires, the defrost is terminated 2:Stop on temp: When the defrost sensor temperature becomes greater than the set point "D43,Def. stop temp. limit", then the defrost is terminated. If the defrost time exceed "D58,Max defrost time", then the alarm 'Max defrost time' is send and the defrost is terminated. In case of sensor error, and the time 'Max defrost time' expires, the alarm 'Max defrost time' is send and the defrost is terminated. The alarm will automatically be reset after 5 minutes. To assign defrost sensor temperature, go to I/O configuration in Main menu and select an available AI	1	2	1=Stop on time		0	Yes	Password level 1,2,3	3	3078	RW	Yes	3, 4 & 16
D41	Man. defrost stop	Manual defrost stop Option to, local on EKE 400, to stop defrost. Can also be used from a PLC connected via MODBUS No: Function disable Yes: Function enabled - Observe. All states (See Fig. 1 - Defrost sequence) before and after Defrost sequence state: "Defrost state" will be still be executed ("Defrost state" will be ignored/supressed) When defrost is completed, "D41, Man. defrost stop" will automatically be set back to "No".	0=No	1=Yes	0=No		0	No	Password level 1,2,3	2	3079	RW	No	3, 4 & 16

Label ID	Parameter name	Description and selection options	Min.	Max	Factory Setting	Unit	Decimals	Locked by Main switch Yes/No	Read	Password level to change/write	Modbus address	Read only (RO) / Read Write (RW)	Persistent Yes/No	Modbus function
D42	Defrost stop via DI	Defrost stop via DI Forced stop defrost via external equipment (e.g. PLC) to EKE 400, via DI No: Function disable Yes: Function enabled- Observe. All states (See Fig. 1 - Defrost sequence) before and after Defrost sequence state: "Defrost state" will be still be executed ("Defrost state" will be ignored/surpressed) To assign DI, go to I/O configuration in Main menu and select an available DI"	0=No	1=Yes	0=No		0	Yes	Pass- word level 1,2,3	3	3080	RW	Yes	3, 4 & 16
D43	Def. stop temp. limit	Defrost stop temperature limit See "D40, Defrost stop method"	0.0	25.0	8.0	°C	1	No	Pass- word level 1,2,3	2	3081	RW	Yes	3, 4 & 16
Defrost function \ Defrost sequence														
D50	Pump down delay	Pump down delay Draining the evaporator before defrosting. Always active The pump down state is used to empty the evaporator for liquid. See Fig. 1 - Defrost sequence	1	30	10	min	0	No	Pass- word level 1,2,3	2	3086	RW	Yes	3, 4 & 16
D51	HG open delay	Hot Gas open delay Time delay in minutes before opening the hot gas valve (delay for valve in the wet return line to close) See Fig. 1 - Defrost sequence	1	10	5	min	0	No	Pass- word level 1,2,3	2	3087	RW	Yes	3, 4 & 16
D5A	Drip tray pre-heat	Drip tray pre-heat Pre-heating time for hot gas to drip tray See Fig. 1 - Defrost sequence	0	20	5	min	0	No	Pass- word level 1,2,3	2	3256	RW	Yes	3, 4 & 16
D5B	Drip tray delay OFF	Drip tray delay OFF Continue drip tray heating some defined time See Fig. 1 - Defrost sequence	0	120	30	min	0	No	Pass- word level 1,2,3	2	3257	RW	Yes	3, 4 & 16
D53	HG soft time	Hot gas soft time Time between step 1 and step 2 for opening the hot gas valve (2 DO used) See Fig. 1 - Defrost sequence	1	30	3	min	0	No	Pass- word level 1,2,3	2	3098	RW	Yes	3, 4 & 16
D54	HG time step 1	Hot Gas time step 1 ICM Motorvalve: Step 1 time controlled opening to "D55, HG OD step 1" See Fig. 1 - Defrost sequence	0	30	3	min	0	No	Pass- word level 1,2,3	2	3099	RW	Yes	3, 4 & 16
D55	HG OD step 1	Hot Gas valve Opening Degree step 1 ICM Motorvalve: Valve opening from 0% to "D55, HG OD step 1" inside "D54,HG time step 1" time. See Fig. 1 - Defrost sequence	0	100	20	%	0	No	Pass- word level 1,2,3	2	3100	RW	Yes	3, 4 & 16
D56	HG time step 2	Hot Gas time step 2 ICM Motorvalve: Controlled opening in step 2 See Fig. 1 - Defrost sequence	1	30	2	min	0	No	Pass- word level 1,2,3	2	3101	RW	Yes	3, 4 & 16
D57	Quick drain time	Quick drain time Enter how long time the Quick Drain valve stays open. Quick Drain valve will start opening together with Hot gas valve See Fig. 1 - Defrost sequence	1	300	30	sec	0	No	Pass- word level 1,2,3	2	3102	RW	Yes	3, 4 & 16
D58	Max defrost time	Max defrost time Max. allowed defrost duration in minutes	1	120	30	min	0	No	Pass- word level 1,2,3	2	3089	RW	Yes	3, 4 & 16
D5C	HG close delay	Hot Gas close delay Delay before closing the selected valves in the Hot gas line (Soft (ICS+EVRST)" or "Soft (ICSH)" or "Slow (ICM)") See Fig. 1 - Defrost sequence	0	120	15	sec	0	No	Pass- word level 1,2,3	2	3258	RW	Yes	3, 4 & 16
D5D	Drain close delay	Drain close delay Delay before the Drain valve is closed See Fig. 1 - Defrost sequence	0	10	2	min	0	No	Pass- word level 1,2,3	2	3259	RW	Yes	3, 4 & 16

Label ID	Parameter name	Description and selection options	Min.	Max	Factory Setting	Unit	Decimals	Locked by Main switch Yes/No	Read	Password level to change/write	Modbus address	Read only (RO) / Read Write (RW)	Persistent Yes/No	Modbus function
D59	Drip off time	Drip off time Allow water on the evaporator to drip off. See Fig. 1 - Defrost sequence	1	15	5	min	0	No	Password level 1,2,3	2	3090	RW	Yes	3, 4 & 16
D61	WR soft time	Wet return soft time Time between step 1 and step 2 for opening the wet return valve ("Soft (ICS+EVRST)" or "Soft (ICSH) See Fig. 1 - Defrost sequence	1	30	2	min	0	No	Password level 1,2,3	2	3094	RW	Yes	3, 4 & 16
D6A	WR main time	Wet return main time After defrost and wet return valve has opened (main), enter delay before valve in liquid line to open. See Fig. 1 - Defrost sequence	1	30	2	min	0	No	Password level 1,2,3	2	3260	RW	Yes	3, 4 & 16
D62	WR time step 1	Wet return time step 1 ICM Motorvalve: Step 1 controlled opening to "D63,WR OD step 1" See Fig. 1 - Defrost sequence	0	30	3	min	0	No	Password level 1,2,3	2	3095	RW	Yes	3, 4 & 16
D63	WR OD step 1	Wet return Opening Degree step 1 ICM Motorvalve: Valve opening from 0% to "D63,WR OD step 1" inside "D62,WR time step 1" time See Fig. 1 - Defrost sequence	0	100	20	%	0	No	Password level 1,2,3	2	3096	RW	Yes	3, 4 & 16
D64	WR time step 2	Wet return time step 2 Wet return ICM step 2 time See Fig. 1 - Defrost sequence	1	30	2	min	0	No	Password level 1,2,3	2	3097	RW	Yes	3, 4 & 16
D65	Fan start delay	Fan start delay The fan will be started when the time has elapsed. See Fig. 1 - Defrost sequence	0	30	2	min	0	No	Password level 1,2,3	2	3092	RW	Yes	3, 4 & 16
D66	Fan ctrl. at defrost	Fan control at defrost Define if fans shall run or be stopped during the defrost sequence. No: Fans are stopped Yes: Fans are running See Fig. 1 - Defrost sequence	0=No	1=Yes	0=No		0	No	Password level 1,2,3	3	3093	RW	Yes	3, 4 & 16
D67	Water valve delay	Delay before start of Water valve See "D09, Water valve?" Description	0	240	15	min	0	No	Password level 1,2,3	2	3334	RW	Yes	3, 4 & 16
D68	Water valve time	Time on of Water valve See "D09, Water valve?" Description	1	120	15	min	0	No	Password level 1,2,3	2	3335	RW	Yes	3, 4 & 16
Fan control														
F01	Fan control mode	Fan control mode 0: No control: No control of fans 1: ON-OFF control: (1 DO) The fans are Off when cooling is stopped, and fans are On when cooling is ON 2: ON Control: Fans are ON, also when cooling is stopped. 3: Two step control: (2 DO): The two DO are controlled as below: Cooling Thermostat=ON DO1: ON DO2: OFF Cooling Thermostat=OFF DO1: ON DO2: ON 4: 0-10 V EC fan ctrl: (1 AO), Modulating control via AO See "F02,Fan speed high" and "F03,Fan speed low" 5: 0-10 V EC fan ctrl: (1 AO, 1 DO), Modulating control via AO and DO Same as "F01, Fan control mode =4 plus the DO should be ON when AO has to be larger than 0% and OFF whenever AO is zero (0%)	0	5	1=On-Off control	0	0	Yes	Password level 1,2,3	3	3103	RW	Yes	3, 4 & 16

Label ID	Parameter name	Description and selection options	Min.	Max	Factory Setting	Unit	Decimals	Locked by Main switch Yes/No	Read	Password level to change/write	Modbus address	Read only (RO) / Read Write (RW)	Persistent Yes/No	Modbus function
F02	Fan speed high	Fan speed high Setting for Fan control via AO - High speed Enter Fan speed high in percent in Cooling mode. 100 % equals max. Speed / Maximum AO output of 10V	0	100	100	%	0	No	Password level 1,2,3	2	3104	RW	Yes	3, 4 & 16
F03	Fan speed low	Fan speed low Setting for Fan control via AO - High speed Enter Fan speed low in percent when not in Cooling mode. 100 % equals max. Speed / Maximum AO output of 10V	0	100	50	%	0	No	Password level 1,2,3	2	3105	RW	Yes	3, 4 & 16
Miscellaneous														
P01	Display unit	Display unit 0:MET: Metric units - Celsius (°C) and Kelvin (°K) 1:IMP: Imperial units - Fahrenheit (°F) and Rankine (°R)	0	1	0=MET		0	No	Password level 1,2,3	2	3115	RW	Yes	3, 4 & 16
P02	Alarm output	Alarm output An alarm relay output can be configured, which will be activated in the event of an alarm. Select the alarm priority that will activate the relay. See Alarm priorities in Main Menu 0: No relay: 1: Critical alarms - To assign DO, go to I/O configuration in Main menu and select an available DO 2: Severe alarms - To assign DO, go to I/O configuration in Main menu and select an available DO 3: All alarms - To assign DO, go to I/O configuration in Main menu and select an available DO	0	3	0=No relay		0	Yes	Password level 1,2,3	3	3116	RW	Yes	3, 4 & 16
cAB	Buzzer Management	Buzzer Management Select whic group af alarms that will activate the buzzer. 0: No buzzer: 1: Critical alarms: 2: Severe alarms: 3: All alarms	0	3	0=No buzzer		0	Yes	Password level 1,2,3	3	3274	RW	Yes	3, 4 & 16
P03	Main switch via DI	Mainswitch via DI Release EKE 400 for operation or force EKE 400 out of operation via external equipment (e.g. PLC), via DI OFF: EKE 400 is forced out of operation. Observe if "M01,Main switch" is ON, this parameter will also when OFF, force EKE 400 out of operation ON: EKE 400 released for operation. Observe if "M01,Main switch" is ON, this parameter must also be ON, to release EKE 400 for operation	0=No	1=Yes	0=No		0	Yes	Password level 1,2,3	3	3117	RW	Yes	3, 4 & 16
P10	Ext ref. config.	External reference configuration Select the signal used to change the thermostat or Media temp. reference. 0: Not used: 1: Displace by current: - define the AI input range via the following settings: "P13,Ref. current high": 4 to 20 mA, default = 20 "P14,Ref. current low": 0 to 20 mA, default = 4 To assign AO, go to I/O configuration in Main menu and select an available AO. 2: Displace by voltage: - define the AI input range via the following settings: "P15,Ref. voltage high": 0 to 10 Volt, default = 10 "P16,Ref. voltage low": 0 to 10 Volt, default = 0 To assign AO, go to I/O configuration in Main menu and select an available AO. 3: Displace by modbus	0	3	0=Not used		0	Yes	Password level 1,2,3	3	3118	RW	Yes	3, 4 & 16

Label ID	Parameter name	Description and selection options	Min.	Max	Factory Setting	Unit	Decimals	Locked by Main switch Yes/No	Read	Password level to change/write	Modbus address	Read only (RO) / Read Write (RW)	Persistent Yes/No	Modbus function
P11	Ref. offset max	Reference offset maximum Scaling of range for temperature displacement - Maximum value See "P10, Ext ref. config."	0.0	50.0	0.0	°C	1	No	Pass-word level 1,2,3	3	3119	RW	Yes	3, 4 & 16
P12	Ref. offset min	Reference offset minimum Scaling of range for temperature displacement - Minimum value See "P10, Ext ref. config."	-50.0	0.0	0.0	°C	1	No	Pass-word level 1,2,3	3	3120	RW	Yes	3, 4 & 16
P13	Ref. current high	Reference current high Scaling of range for AI current - high value See "P10, Ext ref. config."	4.0	20.0	20.0	mA	1	No	Pass-word level 1,2,3	3	3121	RW	Yes	3, 4 & 16
P14	Ref. current low	Reference current low Scaling of range for AI current - low value See "P10, Ext ref. config."	0.0	20.0	4.0	mA	1	No	Pass-word level 1,2,3	3	3122	RW	Yes	3, 4 & 16
P15	Ref. voltage high	Reference voltage high Scaling of range for AI voltage - high value See "P10, Ext ref. config."	0.0	10.0	10.0	V	1	No	Pass-word level 1,2,3	3	3123	RW	Yes	3, 4 & 16
P16	Ref. voltage low	Reference voltage low Scaling of range for AI voltage - low value See "P10, Ext ref. config."	0.0	10.0	0.0	V	1	No	Pass-word level 1,2,3	3	3124	RW	Yes	3, 4 & 16
P17	Lowpass bandwidth	Lowpass bandwidth The analog input signal selected in "P10, Ext ref. config." can be filtered. Contact Danfoss for further information 0: None: 1: 4 Hz: 2: 2 Hz: 3: 1 Hz: 4: 0.5 Hz: 5: 0.2 Hz	0	5	5=0.2	Hz	0	No	Pass-word level 1,2,3	3	3125	RW	Yes	3, 4 & 16
P18	Ref. offset by modbus	Reference offset by MODBUS Offset value via MODBUS (e.g. PLC) added to "T04, Ther. setpoint"	-50.0	50.0	0.0	°C	1	No	Pass-word level 1,2,3	3	3126	RW	Yes	3, 4 & 16
P20	Ther. sensor error	Thermostat sensor error If no thermostat sensor is available because of sensor faults, then emergency cooling takes over to maintain a reasonable level of cooling Select action at emergency cooling mode 0: Stop cooling 1: Fixed OD: This means that the Evaporator will run in a ON/OFF cycle defined by a period of 1 hour and the setting of parameter "P22, Fixed OD emer. cool" E.g. "P22, Fixed OD emer. cool" = 40% Evaporator ON: 40% x 60 min=24 min Evaporator OFF: (100%-40%) x 60 min=36 min 2: Use average values	0	2	2=Use average values		0	No	Pass-word level 1,2,3	3	3127	RW	Yes	3, 4 & 16
P22	Fixed OD emer. cool	Fixed valve Opening Degree emergency cooling Fixed valve OD at emergency cooling of the Liquid line valve See "P20, Ther. sensor error"	0	100	0	%	0	No	Pass-word level 1,2,3	3	3129	RW	Yes	3, 4 & 16
P25	Gas Conc.tra. AI?	Gas Concentration Analog Input	No	Yes	No		0	Yes	Pass-word level 1,2,3	3	3326	RW	Yes	3, 4 & 16
System \ Display														
G01	Language	Languages 0: English 5: Spanish 12: Portuguese 13: Chinese"	0	13	0=English		0	No	Pass-word level 1,2,3	2	3106	RW	Yes	3, 4 & 16
G02	Time format	Time format 0:24-hour format 1:12-hour format:	0	1	0=24-hour format		0	No	Pass-word level 1,2,3	2	3107	RW	Yes	3, 4 & 16

Label ID	Parameter name	Description and selection options	Min.	Max	Factory Setting	Unit	Decimals	Locked by Main switch Yes/No	Read	Password level to change/write	Modbus address	Read only (RO) / Read Write (RW)	Persistent Yes/No	Modbus function
G03	Screen saver time	Screen saver time If no push bottoms have been activated for the entered period, the backlight in the display will be weaker. Display backlight will revoked upon activation of any of the push bottoms	1	60	2	min	0	No	Pass-word level 1,2,3	2	3189	RW	Yes	3, 4 & 16
G04	User logout time	User logout time If no push bottoms have been activated for the entered period, a logout will be carried out to Password level 0. Level 0 will only allow to see the screens: "Status screen 1", "Active alarms", "Alarm Reset" and "Controller info" A forced logout to Password level 0 can be made from screen: "Status screen 1" - Push the "Escape" button for 3 seconds	1	60	2	min	0	No	Pass-word level 1,2,3	2	3191	RW	Yes	3, 4 & 16
G05	Display contrast	Display contrast	0	100	30		0	No	Pass-word level 1,2,3	2	3190	RW	Yes	3, 4 & 16
System \ Password														
G07	Password level 1	Password level 1 Enter password for level 1 access. Level 1 will give access to see all parameters and sub menus, but no settings can be changed. See Column "Read" and "Password level to change/write"	1	999	100		0	No	Pass-word level 1,2,3	1	3108	RW	Yes	3, 4 & 16
G08	Password level 2	Password level 2 Enter password for level 2 access. Level 2 will give access to see all parameters and sub menus. Some settings can be changed. See Column "Read" and "Password level to change/write"	1	999	200		0	No	Pass-word level 2,3	2	3109	RW	Yes	3, 4 & 16
G09	Password level 3	Password level 3 Enter password for level 3 access. Level 3 will give access to see all parameters and sub menus. Alle settings can be changed. See Column "Read" and "Password level to change/write"	1	999	300		0	No	Pass-word level 3	3	3110	RW	Yes	3, 4 & 16
System \ Real time clock														
G10	Real time clock	"Real time clock Enter date (year, month and day) and time (hour and minute)"						No	Pass-word level 1,2,3	2	"1807 (to read) 1809 (to set)"	RW	Yes	3, 4 & 16
System \ Network														
G11	Modbus address	Modbus address Set the address of the controller here if it is connected to a system device via data communication.	1	125	1		0	Yes	Pass-word level 1,2,3	3	3111	RW	Yes	3, 4 & 16
G12	Baudrate	Baudrate The system unit usually communicates with 38,400. 0:0 12:1200 24:2400 48:4800 96:9600 144:14400 192:19200 288:28800 384:38400	0	384	384= 38400		0	Yes	Pass-word level 1,2,3	3	3112	RW	Yes	3, 4 & 16
G13	Serial mode	Serial mode Serial modbus mode. 8N1, 8E1 (8 bit, Even parity) , 8N2	8N1	8N2	8E1		0	Yes	Pass-word level 1,2,3	3	3113	RW	Yes	3, 4 & 16
System \ Reset to factory														

Label ID	Parameter name	Description and selection options	Min.	Max	Factory Setting	Unit	Decimals	Locked by Main switch Yes/No	Read	Password level to change/write	Modbus address	Read only (RO) / Read Write (RW)	Persistent Yes/No	Modbus function
G14	Reset to factory	Reset to factory No: Not active Yes: All parameters will be returned to factory default settings, and the alarm list will be cleared. The parameter will automatically be set back to 'No' when factory reset has finished (after a few seconds). OBSERVE below mention parameters will be left unchanged : "G01,Language" "G10,Real time clock" "G11,Modbus address" "G12,Baudrate" "G13,Serial mode"	0=No	1=Yes	0=No			Yes	Pass-word level 3	3	3114	RW	Yes	3, 4 & 16
Control status / read-outs Control Status - See Table 1. OBSERVE some readouts are only visible under specific conditions														
S01	Control state	Read out of the actual state EKE will proceed during cooling and defrost. See sheet "0-Tables" Table 1 in this document					0				3270	RO	No	3
S02	Cooling status	Status of EKE 400 in status cooling. OFF: No request for cooling. ON: Request for cooling. Can be used via MODBUS (e.g. PLC)					0				3165	RO	No	3
S03	Ther. temp.	"Only visible if "T01,Ther. mode" differ (≠) from "None" Temperature used for the thermostat function.				°C	1				3166	RO	No	3
S04	Night status	"Only visible if "T01,Ther. mode" differ (≠) from "None" and "T06,Day/night control"="Yes" Status of day/night operation. On: Night operation					0				3167	RO	No	3
S05	Cut in limit	"Only visible if "T01,Ther. mode" is "Individual ON/OFF" or "Common ON/OFF" Thermostat cut in limit adjusted with night offset				°C	1				3168	RO	No	3
S06	Cut out limit	"Only visible if "T01,Ther. mode" is "Individual ON/OFF" or "Common ON/OFF" Thermostat cut out limit adjusted with night offset				°C	1				3169	RO	No	3
S07	Alarm air temp.	"Only visible if "B01,Air temp. alarm" differ (≠) from "None" Room temperature used for the alarm function				°C	1				3163	RO	No	3
S08	Product temp.	"Only visible if "B05,Product alarm function" = "Yes" Measured product sensor temperature				°C	1				3170	RO	No	3
S09	Defrosting time	The duration of the last executed defrost is shown				min	0				3171	RO	No	3
S10	Def. sensor temp.	"Only visible if "D40,Defrost stop method"="Stop on time" Defrost sensor temperature				°C	1				3172	RO	No	3
S11	Defrost state time	Actual active time delay shown in actual state				min	0				3173	RO	No	3
S12	Act. state time	Actual remaining time left of "S11,Defrost state time				min	0				3174	RO	No	3
S24	Hours from Defrost	Time in hours since last defrost				hours	0				3319	RO	No	3
S26	Emergency control period	Emergency control period time in minutes				min	0				3321	RO	No	3
S27	Emergency control duty	Emergency control duty time in minutes				min	0				3322	RO	No	3
S28	Gas Conc.tra.	Gas Concentration [ppm]	0	1000		ppm	0				3330	RO	No	3
IO configuration \ Digital outputs														
	DO1...DO8	When a function that needs to use an Digital Output (DO) is defined, it will be possible to assign this function to one of the available DO. Select the function to assign to the actual DO and if the function is to be active when the DO is activated or deactivated.												
IO configuration \ Digital inputs														
	DI1...DI8	When a function that needs to use an Digital Input (DI) is defined, it will be possible to assign this function to one of the available DI. Select the function to assign to the actual DI.												

Label ID	Parameter name	Description and selection options	Min.	Max	Factory Setting	Unit	Decimals	Locked by Main switch Yes/No	Read	Password level to change/write	Modbus address	Read only (RO) / Read Write (RW)	Persistent Yes/No	Modbus function
IO configuration \ Analog outputs - Voltage														
	AO1, AO2, AO3, AO4	When a function that needs to use an Analog Output (DO) is defined, it will be possible to assign this function to one of the available AO. Select the function to assign to the actual AO and define voltage range 0-1V, 0-5 or 0-10 V												
IO configuration \ Analog inputs														
	AI1...AI8	When a temperaturefunction that needs to use an Analog Input (AI) is defined, it will be possible to assign this function to one of the available AI. Select the function to assign to the actual AI. It is possible to add an offset value to compensate for long cables under "Cal." parameter												
IO status \ Digital outputs														
	DO1...DO8	Status (OFF/ON) if all DO. If a function is assigned the function name will be displayed. DO not used, will display "-----"												
	DO1	Actual assigned parameter to DO									1003.8	RO		3
	DO2										1003.9	RO		3
	DO3										1003.10	RO		3
	DO4										1003.11	RO		3
	DO5										1003.12	RO		3
	DO6										1003.13	RO		3
	DO7										1003.14	RO		3
	DO8										1003.15	RO		3
IO status \ Digital inputs														
	DI1...DI8	Status (OFF/ON) if all DI. If a function is assigned the function name will be displayed. DI not used, will display "-----"												
	DI1	Actual assigned parameter to DI									1001.8	RO		3
	DI2										1001.9	RO		3
	DI3										1001.10	RO		3
	DI4										1001.11	RO		3
	DI5										1001.12	RO		3
	DI6										1001.13	RO		3
	DI7										1001.14	RO		3
	DI8										1001.15	RO		3
IO status \ Analog outputs														
	AO1, AO2, AO3, AO4	Status of analogue outputs. Value in 0-100 % max. Output signal												
	AO1	Actual assigned parameter to AO									1037	RO		3
	AO2										1038	RO		3
	AO3										1039	RO		3
	AO4										1040	RO		3
IO status \ Analog inputs														
	AI1...AI8	Status of analogue temperature inputs. Temperature values (includes possible offset calibration values).												

Label ID	Parameter name	Description and selection options	Min.	Max	Factory Setting	Unit	Decimals	Locked by Main switch Yes/No	Read	Pass-word level to change/write	Modbus address	Read only (RO) / Read Write (RW)	Persistent Yes/No	Modbus function
	AI1	Actual assigned parameter to AI									1005	RO		3
	AI2										1006	RO		3
	AI3										1007	RO		3
	AI4										1008	RO		3
	AI5										1009	RO		3
	AI6										1010	RO		3
	AI7										1011	RO		3
	AI8										1012	RO		3
IO status \ IO summary														
	IO summary	Inputs and outputs overview. Display of maximum available and how many is actual being used. OBSERVE: If too many have been defined, an exclamation mark (!) will appear.												
IO manual control \ Digital outputs														
	DO1...DO8	Manual override control of a DO. AUTO : DO is controlled automatically by EKE 400 ON: DO is forced ON - an alarm is will be active "Output in manual mode" OFF: DO is forced OFF OBSERVE: Remember to switch back to "AUTO" when an override have been made (OFF/ON)												
IO manual control \ Analog outputs														
	AO1, AO2, AO3, AO4	Manual override control of a AO. AUTO : AO is controlled automatically by EKE 400 MAN: If MAN is selected, A manual output value [0-100 %] of max. AO value can be entered in parameter "Man". - an alarm is will be active "Output in manual mode" OBSERVE: Remember to switch back to "AUTO" when an override have been selected ("MAN")												
Alarm settings\ alarm priorities														
		The controller will issue an alarm notification if a specific incident occurs. Each incident is set to indicate the importance of each alarm, but it is possible to modify the importance of each. Choose between the following priority levels: 0: Critical: Important alarms that require a high level of attention. 1: Severe: Alarms of intermediate importance 2: Normal: No important alarms 3: Disable: Alarms set to this priority level will be cancelled.												
A50	Ther. air sensor error	Thermostat sensor is defect	0	3	2			No	Pass-word level 1,2,3	2	3132	RW	No	3,4 & 16
A51	Ther. air 2 sensor error	Thermostat sensor 2 is defect	0	3	2			No	Pass-word level 1,2,3	2	3133	RW	No	3,4 & 16
A52	Ther. air 3 sensor error	Thermostat sensor 3 is defect	0	3	2			No	Pass-word level 1,2,3	2	3134	RW	No	3,4 & 16
A53	Room alarm sensor error	Room alarm sensor is defect	0	3	2			No	Pass-word level 1,2,3	2	3135	RW	No	3,4 & 16

Label ID	Parameter name	Description and selection options	Min.	Max	Factory Setting	Unit	Decimals	Locked by Main switch Yes/No	Read	Password level to change/write	Modbus address	Read only (RO) / Read Write (RW)	Persistent Yes/No	Modbus function
A54	Defrost sensor error	Defrost sensor is defect	0	3	2			No	Password level 1,2,3	2	3136	RW	No	3, 4 & 16
A55	Product sensor error	Product sensor is defect	0	3	2			No	Password level 1,2,3	2	3137	RW	No	3, 4 & 16
A59	Standby mode	Alarm when control is stopped by internal or external Main Switch (DI input)	0	3	2			No	Password level 1,2,3	2	3141	RW	No	3, 4 & 16
A61	High temp. alarm	The room temperature is too high	0	3	0			No	Password level 1,2,3	2	3143	RW	No	3, 4 & 16
A62	Low temp. alarm	The room temperature is too low	0	3	0			No	Password level 1,2,3	2	3144	RW	No	3, 4 & 16
A63	High product temp. alarm	The product temperature is too high	0	3	1			No	Password level 1,2,3	2	3145	RW	No	3, 4 & 16
A64	Low product temp. alarm	The product temperature is too low	0	3	1			No	Password level 1,2,3	2	3146	RW	No	3, 4 & 16
A65	Max. defrost time	The max allowed defrost time is exceeded	0	3	2			No	Password level 1,2,3	2	3147	RW	No	3, 4 & 16
A66	Output in MAN mode	An output is set in manual mode	0	3	2			No	Password level 1,2,3	2	3148	RW	No	3, 4 & 16
A67	IO config. error	Not all inputs and output functions have been assigned to hardware Inputs or outputs	0	3	-			No			3149	RW	No	3, 4 & 16
A68	Critical Alarm	Critical Alarm by DI	0	3	0			No	Password level 1,2,3	2	3332	RW	No	3, 4 & 16
Alarm setting\ Critical Alarm														
S70	Manual alarm reset	Manual alarm reset of Critical Alarm, selec YES to reset	No	Yes	No		0	No	Password level 1,2,3	3	3333	RW	Yes	3, 4 & 16
A70	Crit.alarm status	Critical Alarm status 0 = not active 1 = active	0	1			0	No			3329	RW	Yes	3, 4 & 16
A71	Crit.ext.alarm DI?	Enable DI for Critical Alarm	No	Yes	No		0	Yes	Password level 1,2,3	3	3327	RW	Yes	3, 4 & 16
A72	WR alarm mode	Wet Return valve status in Critical Alarm status	OFF	ON	OFF		0	No			3328	RW	Yes	3, 4 & 16
A73	Fan alarm mode	Fan status in Critical Alarm status	OFF	ON	OFF		0	No			3331	RW	Yes	3, 4 & 16

Label ID	Parameter name	Description and selection options	Min.	Max	Factory Setting	Unit	Decimals	Locked by Main switch Yes/No	Read	Pass-word level to change/write	Modbus address	Read only (RO) / Read Write (RW)	Persistent Yes/No	Modbus function
Alarm messages														
	Alarm text	Description									Modbus Address			
E01	Sensor Fault	External reference input defect									1901.09	RO	No	3
A50	Ther. air sensor error	Thermostat sensor is defect									1901.11	RO	No	3
A51	Ther. air 2 sensor error	Thermostat sensor 2 is defect									1901.12	RO	No	3
A52	Ther. air 3 sensor error	Thermostat sensor 3 is defect									1901.13	RO	No	3
A53	Room alarm sensor error	Room alarm sensor is defect									1901.14	RO	No	3
A54	Defrost sensor error	Defrost sensor is defect									1901.15	RO	No	3
A55	Product sensor error	Product sensor is defect									1901.00	RO	No	3
A59	Standby mode	Alarm when control is stopped by internal or external Main Switch (DI input)									1901.04	RO	No	3
A61	High temp. alarm	The room temperature is too high									1901.06	RO	No	3
A62	Low temp. alarm	The room temperature is too low									1901.07	RO	No	3
A63	High product temp. alarm	The product temperature is too high									1902.08	RO	No	3
A64	Low product temp. alarm	The product temperature is too low									1902.09	RO	No	3
A65	Max. defrost time	The max allowed defrost time is exceeded									1902.10	RO	No	3
A66	Output in MAN mode	An output is set in manual mode									1902.11	RO	No	3
A67	IO config. error	Not all inputs and output functions have been assigned to hardware Inputs or outputs									1902.12	RO	No	3

Fig. 1 - Defrost sequence

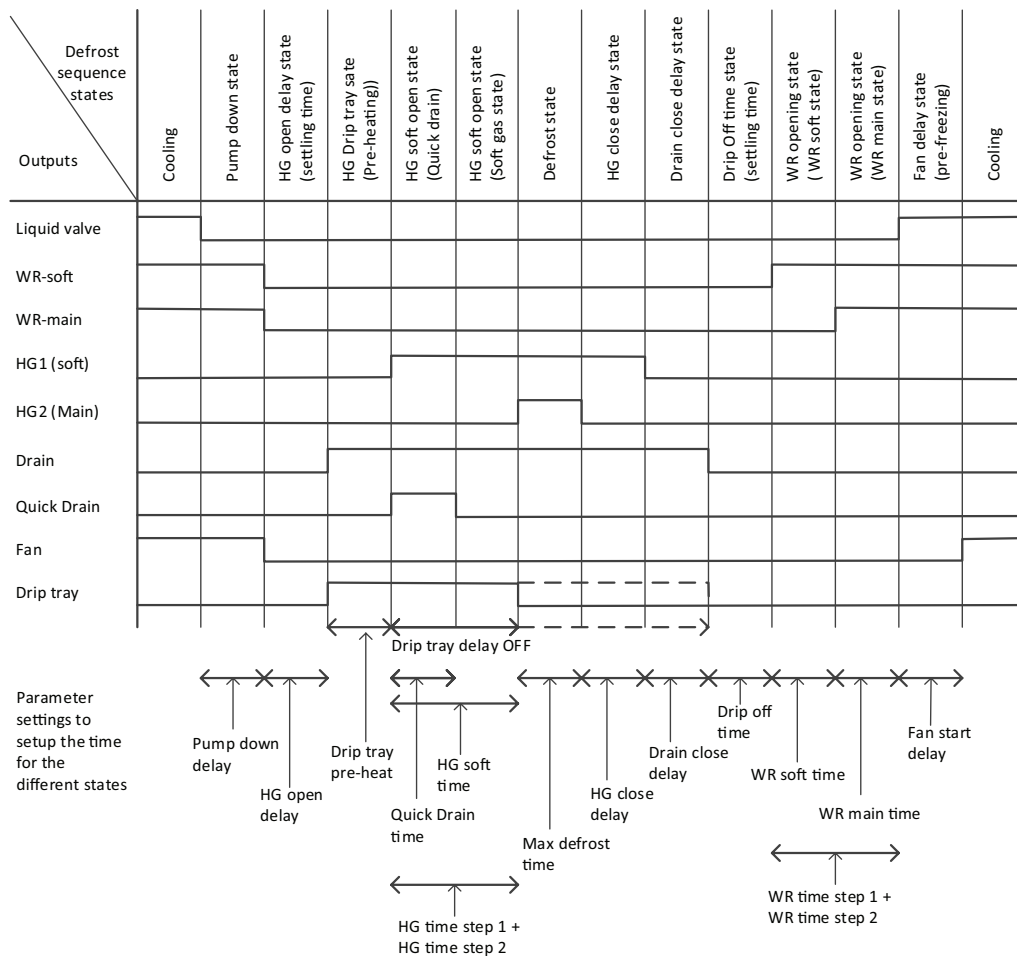

Fig. 2 - Electrical- water- and brine defrost

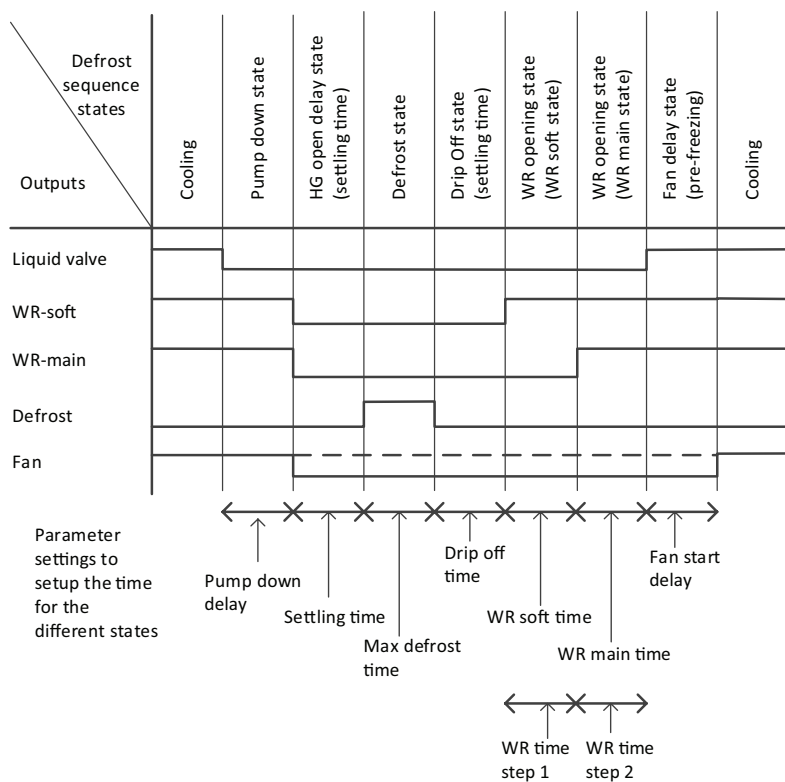

Table 1

Control state number	Message text	Comments
1	Main switch is OFF	Regulation is Off – controller in standby
2	Manual control	One or more of the outputs are overruled by manual control
3	Pump down	Defrost sequence: Pump down state
4	HG open delay	Defrost sequence: Hot gas delay
5	HG Drip tray	Defrost sequence: Hot gas to drip tray
6	HG soft opening	Defrost sequence: Soft open valve
7	Defrosting	Defrost sequence: Defrosting
8	HG close delay	Defrost sequence: Hot gas close delay
9	Drain close delay	Defrost sequence: Drain close delay
10	Drip off time	Defrost sequence: Drip off time
11	WR open delay	Defrost sequence: Equalizing pressure time
12	Fan start delay	Defrost sequence: Fan start delay
14	Forced closing	Forced stop of cooling (close liquid line valve)
15	Forced cooling	Forced cooling (typically to secure enough hot gas)
16	Emergency control	One or more sensor error
19	Cooling	Cooling/refrigeration is active (thermostat cut-in)
20	Cooling stopped	No cooling/refrigeration
22	Power up state	Start up after a power cycle

Input / Output navigation

From any status screen press ENTER for 2 sec. to access main menu.

Enter the correct password

Move to IO configuration

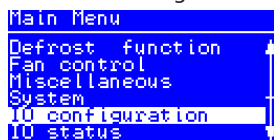

Select relevant menu

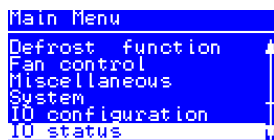
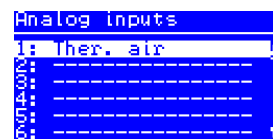
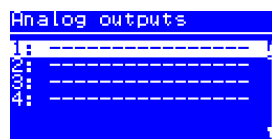
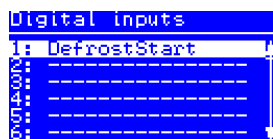
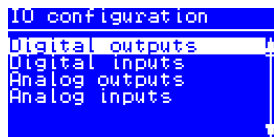

In this image you can see how many outputs and inputs your settings have provided.

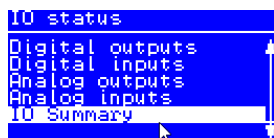

	Max.	Used
DO:	8	6
DI:	8	1
AO:	4	0
AI:	8	1

Connection, lower level

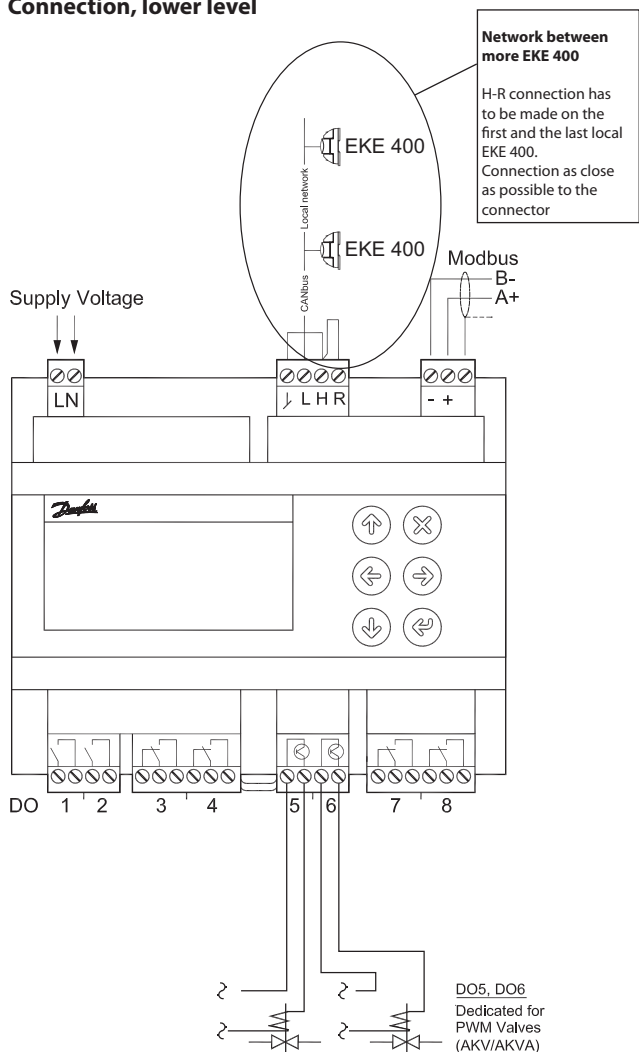

Observe AC only

Connection, upper level

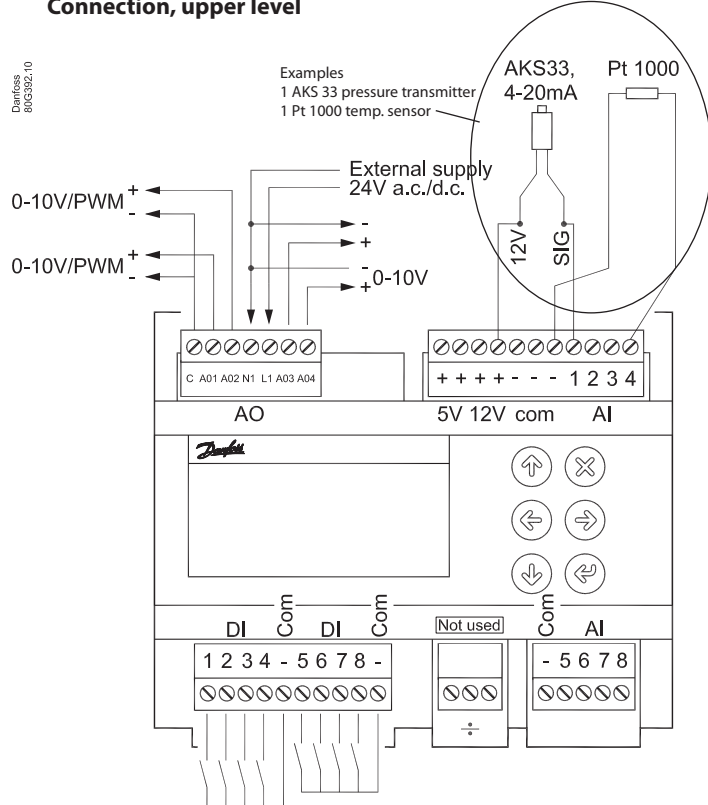

Electric noise
 Signal cables for sensors, DI inputs, data communication and display must be kept separate from high voltage (230 V) electric cables:
 - Use separate cable trays
 - Keep a distance between high voltage and signal cables of at least 10 cm
 Cables for DI input.
 Cables longer than 10 m (33 ft) is not recommended. At cables longer than 10 meter (33 ft), it is recommended to use auxiliary relays, placed within 10 m (33 ft) cable distance. Typical auxiliary relays then are placed in the same panel, as EKE 400.

Valve configuration no.	Evaporator Line	Valve selection in Wizard	Parameter number	DO1	DO2	DO3	DO4	DO5	DO6
1	Liquid feed line	Solenoid (ICFE)	R02	X					
	Hotgas defrost line	Solenoid 2-step (ICSH)	D2A		X	X			
	Defrost drain line	Solenoid (upstream ICFD)	D1B and D4A				X		
	Wet return line	Solenoid 2-step (ICLX)	D3A					X	
	Fan	-	F01						X
2	Liquid feed line	Solenoid (ICFE)	R02	X					
	Hotgas defrost line	Solenoid (ICS)	D2A		X				
	Defrost drain line	Solenoid (upstream ICFD)	D1B and D4A			X			
	Wet return line	Solenoid 2-step (ICLX)	D3A				X		
	Fan	-	F01					X	
3	Liquid feed line	Solenoid (ICFE)	R02	X					
	Hotgas defrost line	Solenoid 2-step (ICSH)	D2A		X	X			
	Defrost drain line	Solenoid for quick drain - pressurecontrol)	D1B and D4A				X		
	Wet return line	Solenoid 2-step (ICLX)	D3A					X	
	Fan	-	F01						X
4	Liquid feed line	Solenoid (ICFE)	R02	X					
	Hotgas defrost line	Solenoid (ICS)	D2A		X				
	Defrost drain line	Solenoid for quick drain - pressurecontrol)	D1B and D4A			X			
	Wet return line	Solenoid 2-step (ICLX)	D3A				X		
	Fan	-	F01					X	

Supply Voltage.

Supply voltage depending on model:
 85 – 265 V AC, 50/60 Hz. Maximum power consumption: 20 V A
 20 – 60 V DC and 24 V AC ± 15% 50/60 Hz , Maximum power consumption: 10 W, 17 V A.

MODBUS

It is important that the installation of the data communication cable be done correctly. Cf. separate literature No. RC8AC. Remember termination at the bus termination.

DO - Digital outputs, 8 pcs. DO1 - DO8

Function defined via the HMI in the parameter list
 DO1, DO2
 - Normally Open contact,
 10 A 250 V AC for resistive loads
 3.5 A 230 V AC for inductive loads

DO3, DO4, DO7, DO8:
 - Changeover Contact,
 6 A 250 V AC for resistive loads
 4 A 250 V AC for inductive loads

DO5, DO6:
 - Solid state relays,
 I_{max}. = 0.5 A
 I_{min}. = 50 mA.
 Leakage < 1.5 mA
 Not short-circuit protected
 OBSERVE: AC only

AO - Analogue output, 4 pcs. AO1, AO2, AO3, AO4

Function defined via the HMI in the parameter list.

AO1, AO2:
 0 / 10 V DC 10 mA max for each output

AO3, AO4:
 Optoinsulated. 0 / 10 V DC 10 mA max for each output
 External power supply 24 V AC / 24 V DC

OBSERVE:
 Connect 24 V on N and L (separate supply). Avoid earth fault current. Use double-insulated transformer. The secondary side must not be earthed.
 Obtain 0-10 volts from terminals N and AO3, respectively N and AO4.
 PAY ATTENTION TO THE POLARITY of N.

AI - Analogue inputs, 4 pcs. AI1 - AI4

Function defined via the HMI in the parameter list

- Pressure transmitters*
- Ratiometric: 10-90% of supply, AKS 32R
 1-5 V, AKS 32
 0-20 mA / 4-20 mA, AKS 33 (supply = 12 V)
 - *Temperature sensor*
 - Pt 1000 ohm, AKS 11 or AKS 21.
 - NTC 86K ohm @ 25 °C, from digital scroll.

DI - Digital inputs, 8 pcs. DI1 - DI8

The connection may be a shut-down or interruption function. Select what is to be activated during configuration.

AI - Analogue inputs, 4 pcs. AI5 - AI8

Function defined via the HMI in the parameter list

- Pressure transmitters*
- Ratiometric: 10-90% of supply, AKS 32R
 1-5 V, AKS 32
 - *Temperature sensor*
 - Pt 1000 ohm, AKS 11 or AKS 21.
 - NTC 86K ohm @ 25° C, from digital scroll.

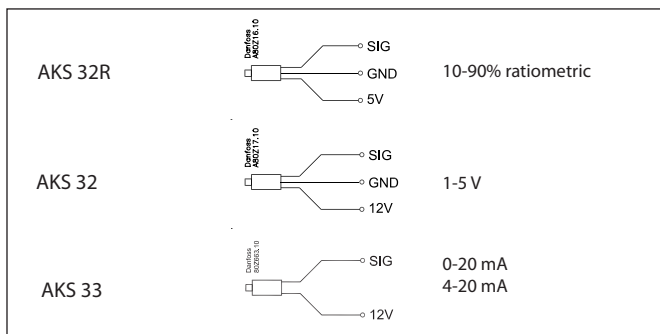

Data

Supply voltage	24 V AC +/-15% 50/60 Hz, 17 VA 24 V DC (20-60 V), 17 VA 230 AC (85-265 V) 50/60 Hz, 20 VA	
8 analog Input	Pressure measuring: Ratiometric pressure transmitter type AKS 32R 1-5 volt pressure transmitter type AKS 32 0-20 (4-20) mA pressure transmitter type AKS 33	
	Temperature measurement Pt 1000 ohm/0 °C NTC - 86K from digital scroll / stream	
8 digital input	From contact function E.g. to: Start/stop of regulation Monitoring of safety circuits General alarm function	
8 digital output	4 pcs. SPDT (8A)	AC-1: 6 A (ohmic) AC-15: 4 A (inductive)
	2 pcs. SPST (16A)	AC-1: 10 A (ohmic) AC-15: 3.5 (inductive)
	2 pcs. Solid State. PWM for solenoid coils and coils for AKV or AKVA. OBSERVE: 24-230 V AC, 50/60 Hz	I _{max.} = 0.5A I _{min.} = 50 mA. Leak < 1.5 mA Not short-circuit protected
2 Voltage output	0-10 V d.c. Ri = 1kohm Separate 24 V supply required	
HMI	Remote HMI, type MMIGRS2	
Data communication	MODBUS for: Third party equipment like e.g PLC	
	CANBUS Communication between EKE 400 units and HMI	
Environments	-20 - 60 °C, During operations	
	-40 - 70 °C, During transport	
	20 - 80% Rh, not condensed No shock influence / vibrations	
Enclosure	IP 20	
Weight	0,4 kg	
Mounting	DIN-rail	
Connection terminals	max. 2.5 mm ² multi core	
Approvals	EU Low Voltage Directive and EMC demands re CE-marking complied with LVD tested acc. EN 60730-1 and EN 60730-2-9 EMC-tested acc. EN61000-6-2 and 3 UL approval	

Pressure transmitter / temperature sensor

Kindly refer to catalogue RK0YG...

Ordering

Type	Function	Operation	Supply voltage	Code no.
EKE 400	Evaporator controller		230 V	080G5003
			24 V	080G5004
			230 V	080G5005
			24 V	080G5006
MMIGRS2	Remote HMI		-	080G0294
	Cable between remote HMI and EKE 400		L = 1.5 m, 1 pcs.	080G0075
	Cable between remote HMI and EKE 400		L = 3 m, 1 pcs.	080G0076

External display

An remote HMI is only for front assembly (IP 20)
Connection only via cable with plug. See ordering.

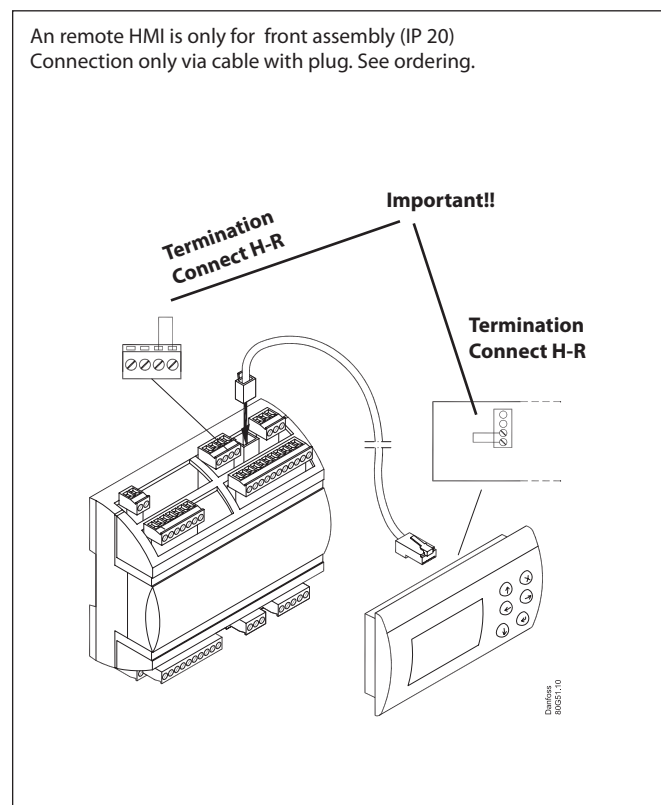

Mounting /Dimensions

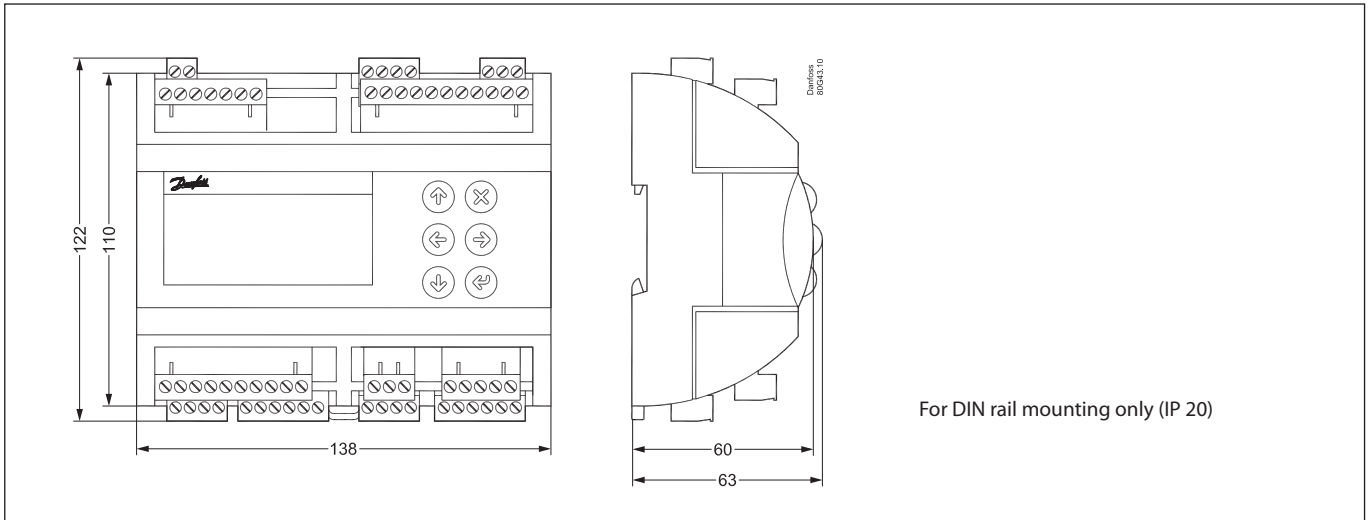

Installation considerations

Accidental damage, poor installation, or site conditions, can give rise to malfunctions of the control system, and ultimately lead to a plant breakdown.

Every possible safeguard is incorporated into our products to prevent this. However, a wrong installation, for example, could still present problems. Electronic controls are no substitute for normal, good engineering practice.

Danfoss will not be responsible for any goods, or plant components, damaged as a result of the above defects. It is the installer's responsibility to check the installation thoroughly, and to fit the necessary safety devices.

Your local Danfoss agent will be pleased to assist with further advice, etc.