

avrora-arm.ru
+7 (495) 956-62-18

ENGINEERING
TOMORROW

Danfoss

Service guide

Disassembling and assembling

APP 53-92 & APP S / APP S 674 53-86

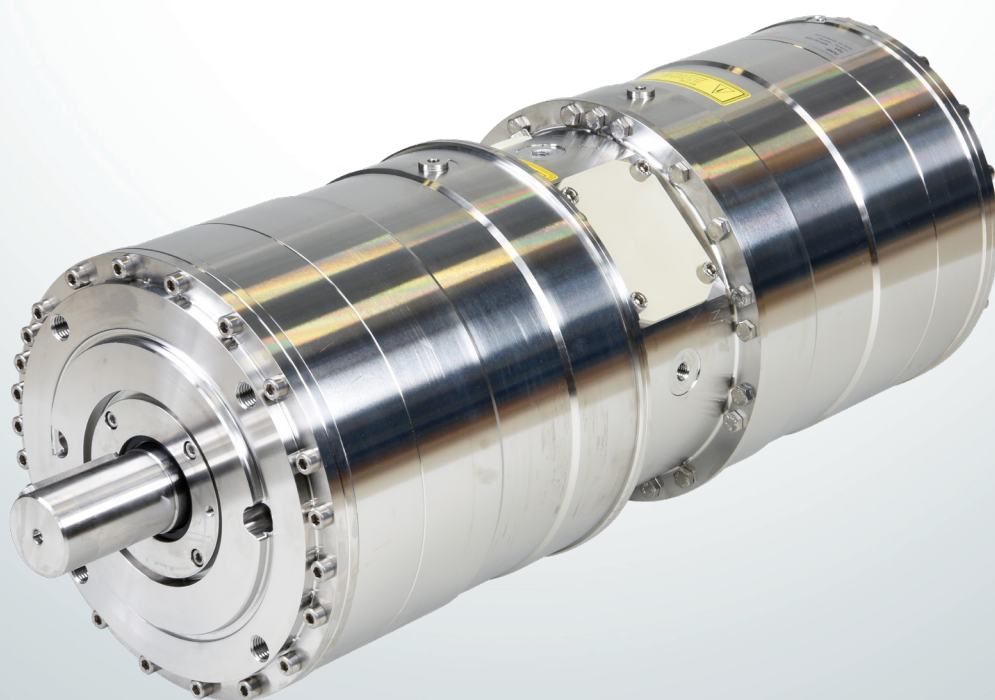

| Table of Contents | Contents |
|-------------------|---|
| 1. | Introduction 2 |
| 2. | Disassembling the pump in horizontal position 3 |
| 3. | Disassembling and assembling of the valve plate 9 |
| 4. | Disassembling shaft and cylinder barrel 11 |
| 5. | Assembling shaft and cylinder barrel 12 |
| 5. | Assembling the pump 15 |
| 6. | Disassembling and assembling of the flushing valve 20 |
| 7. | Changing pistons 20 |
| 8. | Assembling spring package 21 |
| 9. | Exploded view 22 |
| 9.1 | Exploded view APP 53-92 22 |
| 9.2 | Exploded view APP S 53-86 23 |
| 9.3 | Exploded view APP S 674 53-86 24 |
| 10. | When should the pistons be replaced 25 |

1. Introduction

This document covers the instructions for disassembling and assembling the axial piston pumps APP 53-92 & APP S / APP S 674 53-86.

Important: Place the pump horizontally on a pallet or other stable surface above the ground. Ensure that the pump cannot roll.

For a better understanding of the pump, please see the exploded view in section 6.

Tools provided with toolset 180Z0665:

- 1 x cone bushing extractor
- 1 x M8 x 140 screw
- 3 x M8 x 70 screws with nuts
- 3 x valve plate fixation
- 2 x M6 x 65
- 2 x tool washer
- 1 x M16 pin and nut
- 1 x ø30/17 x 3 washer
- 1 x shaft seal press bush tool
- 1 x bracket
- 1 x 8 mm Allen key
- 1 x 6 mm Allen key
- 1 x M8 x 40 with nut
- 2 x combination wrench 13mm
- 1 x combination wrench 24 mm
- 1 x combination wrench 30 mm
- 1 x 24 mm socket (1/2")
- 1 x torque wrench (1/2")
- 1 x valve plate tool
- 2 x screw drivers, 5.5 x 1mm
- 1 x NV24 flush valve tool
- 2 x M8 x 16 bolts
- 1 x valve plate mount

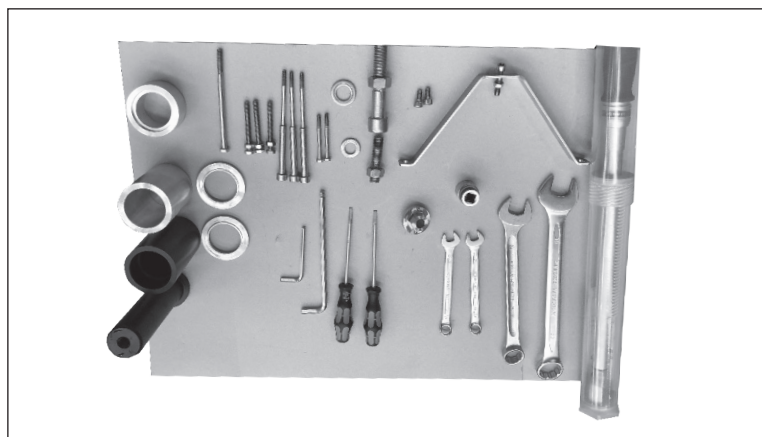

2. Disassembling the pump in horizontal position

Starting from the end flange side:

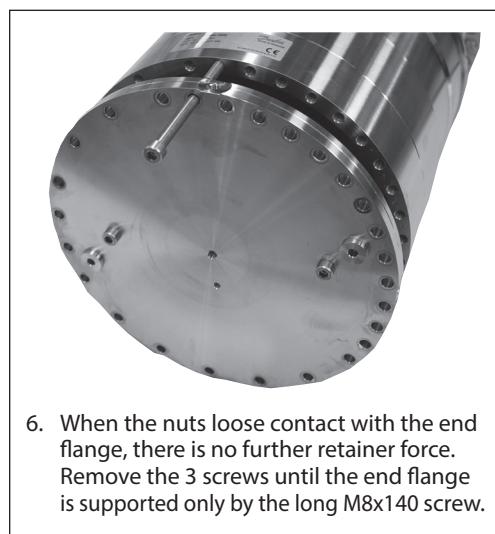
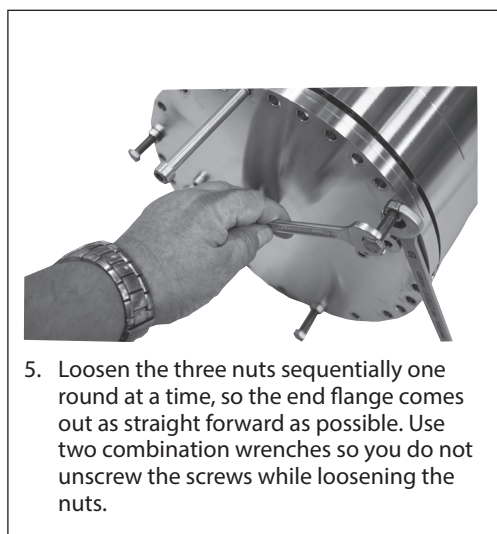
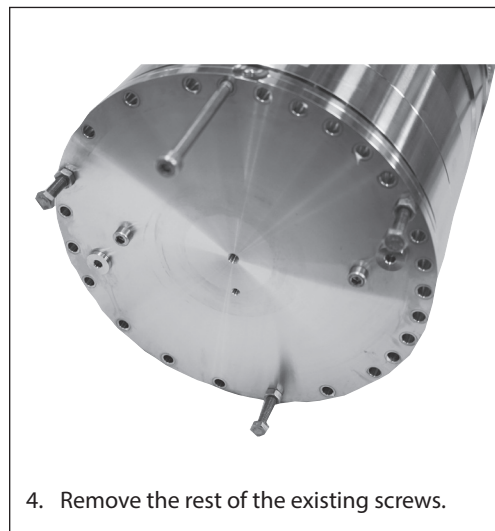
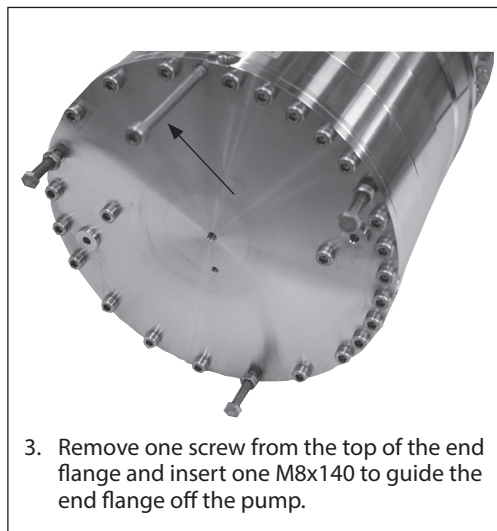
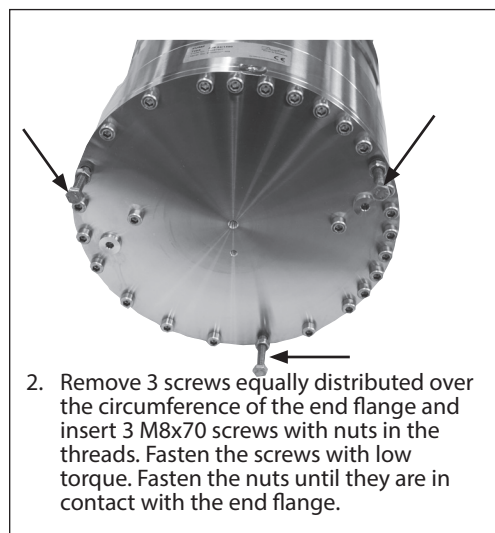
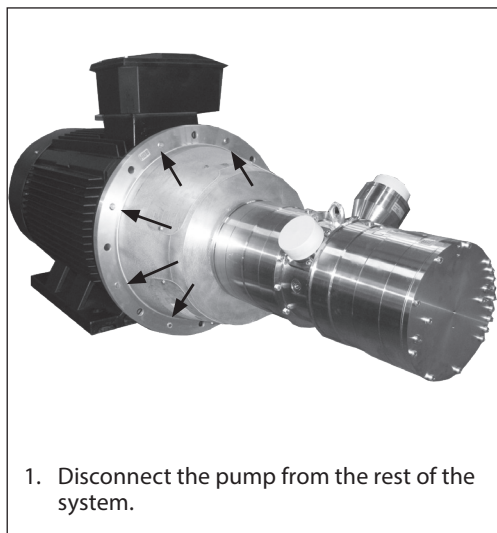

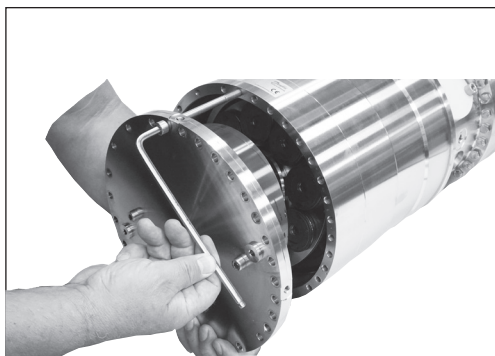

7. Remove the long M8x140 screw and the end flange.
Warning: flange with swash plate is heavy, so make sure not to drop it. Risk of injury.

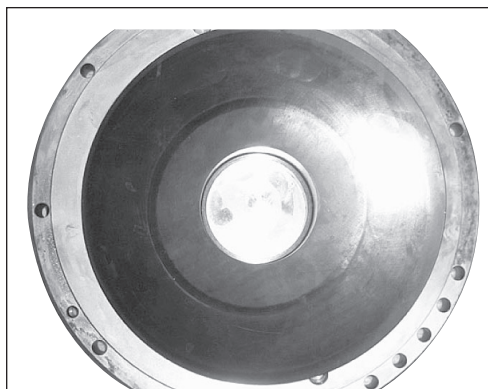

8. End flange should be placed so swash plate surface is not scratched. For further disassembling of swash plate, see section 4.

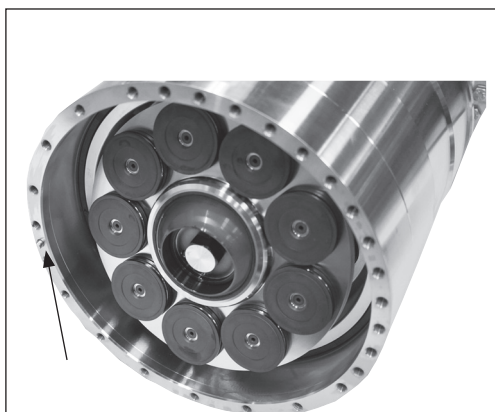

9. Remove the guidepin.



10. Remove by hand the pistons one by one. Be careful not to scratch the pistons. Tilt the retainer plate as needed for easy removal of pistons. When removing the last pistons, hold with one hand the retainer plate to make sure the retainer plate does not drop out. **WARNING: Do not use any tools.**



11. Remove the retainer plate.



12. Remove the retainer ball.



13. Remove the distance washer (unless your pump is an APP / APP S / APP S 674 53), which is not having distance washer). Remove the spring package.

WARNING: Do not disassemble the spring package.

If spring package needs assembling, see instruction for symmetric assembly of springs page 21.

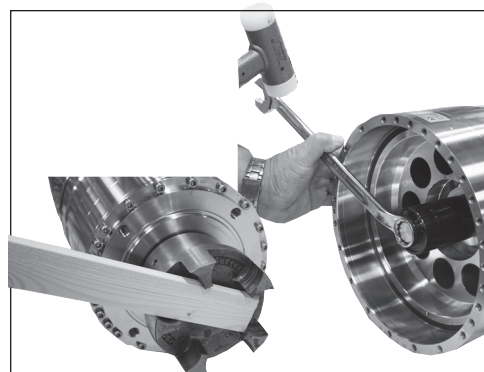

14. Continue with the next steps only if you need to fully disassemble the pump. Unscrew the M16 screw. It may be necessary to lock the shaft so it doesn't turn. Mount the coupling at the other end of the shaft and use it to lock the shaft.

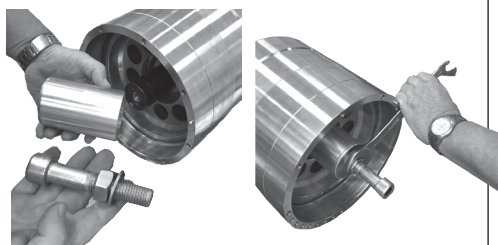

15. Loosen the cone bushing using the cone bushing extractor, but do not remove it.

1. Mount extractor.
2. Screw in the M20 by hand, do not use any torque.
3. Use a 30 mm combination wrench to tighten the nut and washer. The cone bushing will become loose in the cylinder barrel. Do not remove it.
4. See "Disassembling and assembling of valve plate"



16. Remove cone bushing extractor and mount the M16 screw again by hand, do not use any torque.

Move to the motor flange side:



17. If not already done, remove the coupling and shaft key (if your pump model is an APP S / APP S 674 there are no shaft key. The shaft has a spline instead).



18. Remove the 4 M6 screws from the cover for shaft seal. Use 2 M6 screws to extract the cover mounting them into the treads in the cover for shaft seal.

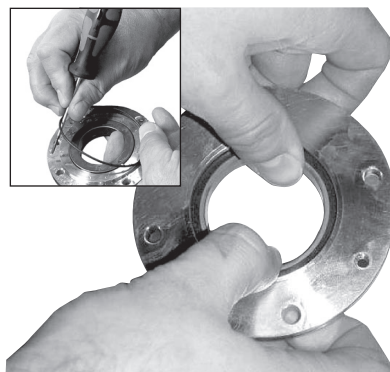

19. If necessary, remove ceramic ring from the cover for shaft seal by gently pushing it from the back of the sealing ring.



20. Remove the motor flange following the same steps described for the end flange (steps 2 to 9). Using the M8 x 140 mm is optional.



21. Remove the shaft seal by hand or using a screw driver between the washer and the shaft seal, if needed.



22. Remove pistons, retainer plate, retainer ball, distance washer, and spring package following the same steps described before for the end flange side (steps 10 to 13).

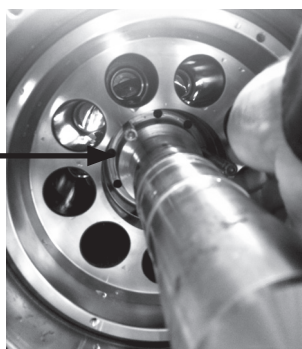

23. Mount 3 valve plate fixations in the valve plate through the holes in the cylinder barrel and fasten them with low torque. Be aware that only three holes in the valve plate have a thread.

Move to the end flange side:

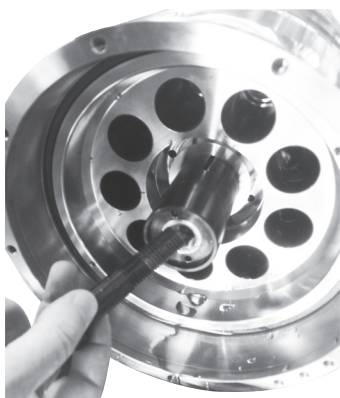

24. Remove the M16 screw in the end flange side.



25. Remove the cone bushing. It was previously loosened in step 15 but if it is too tight using the cone bushing extractor again as described there.



26. Screw 2 M6 x 65 screws in the cylinder barrel.

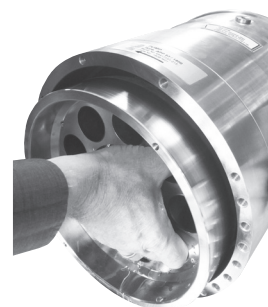

27. Remove the cylinder barrel and valve plate slowly, using the two screws to grasp it, as needed. **WARNING:** Do not scratch the main bearing inside the housing. The assembly is heavy and can be slippery, risk of personal injury.



28. Remove the 2 M6 x 65 screws and place the cylinder barrel on a clean surface with the valve plate on top. For more information on how to disassemble the valve plate assembly, please see the section "Disassembling and assembling of the valve plate".

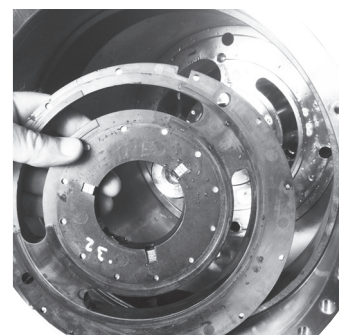

29. Remove the port plate.



30. Remove the guide pins.



31. Remove the distance pipe.

Move to the motor flange side:



32. Carefully remove the cylinder barrel with shaft and valve plate. For more information on how to disassemble the valve plate assembly, please see the section "Disassembling and assembling of the valve plate".

WARNING: Do not scratch the main bearing inside the housing. The assembly is heavy and can be slippery, risk of personal injury.



33. Remove the port plate and guide pins as described before for the end flange side (steps 29 and 30).

3. Disassembling and assembling of the valve plate

With shaft

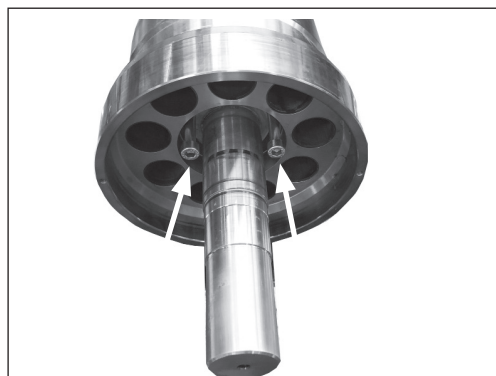

1. Remove the 3 screws that were installed in item 23 to keep the valve plate in place during disassembling. When the screws are removed the valve plate will be pushed out by the springs on the opposite side.

Without shaft

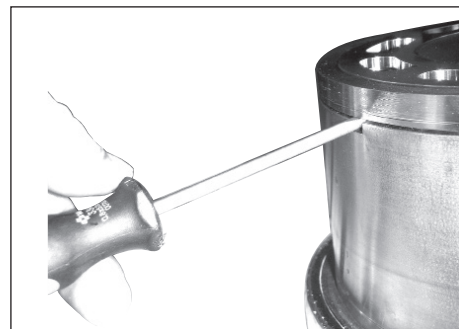

2. Push a screwdriver into the hole between cylinder barrel and valve plate. Carefully push downward the screwdriver so that it makes a gap between cylinder barrel and valve plate. Use this gap to put in another screwdriver and loosen the valve plate from the cylinder barrel.

Assembling cylinder barrel with shaft

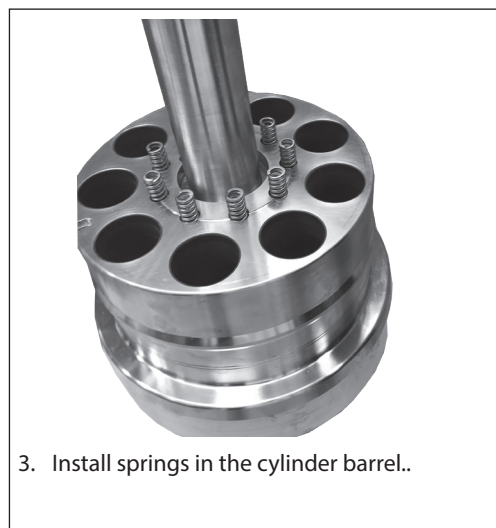

3. Install springs in the cylinder barrel..



4. Place the valve plate on the cylinder barrel. Align the pressure shoes on the valve plate with the bushing in the cylinder barrel.

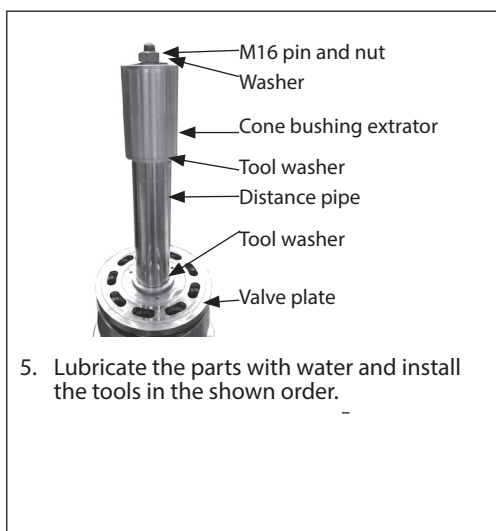

5. Lubricate the parts with water and install the tools in the shown order.



6. Turn the nut to push the valve plate in place. 1mm between valve plate and barrel.

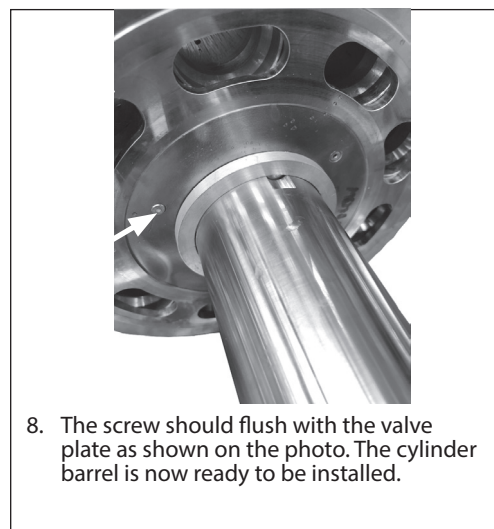
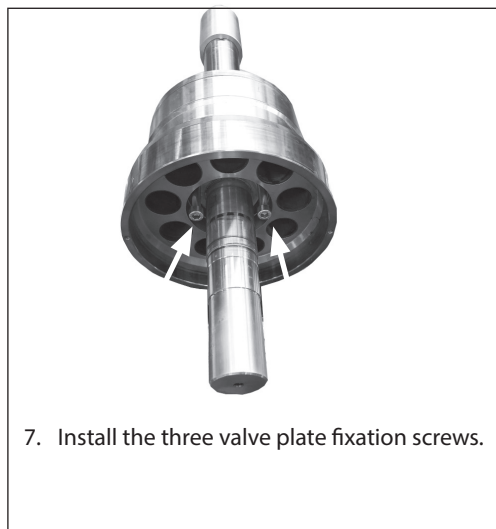

Assembling cylinder barrel without shaft

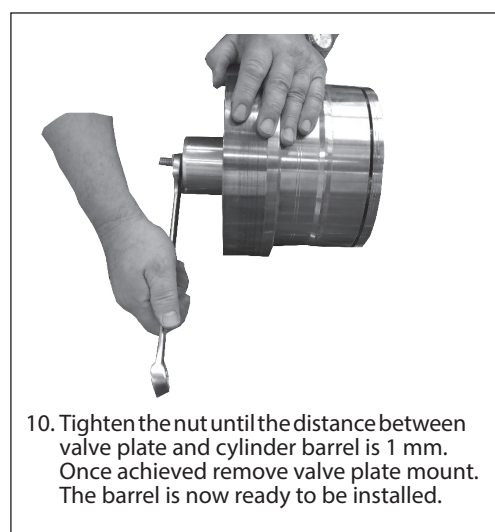
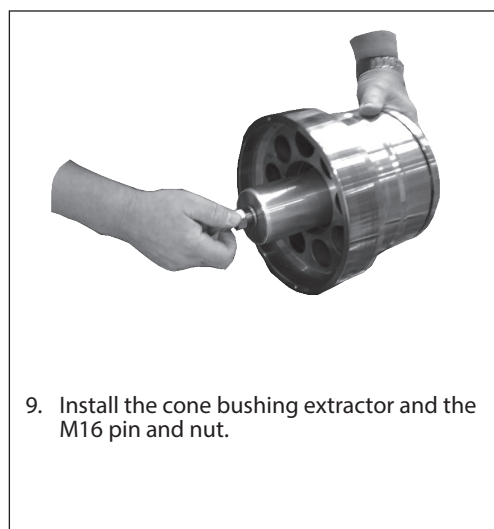
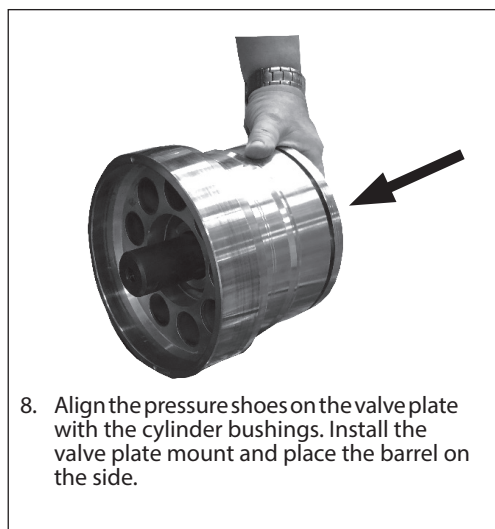

4. Disassembling shaft and cylinder barrel

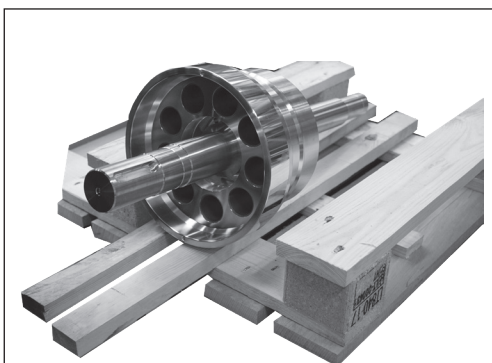

21 surface, that will not damage or scratch the bearing surfaces.

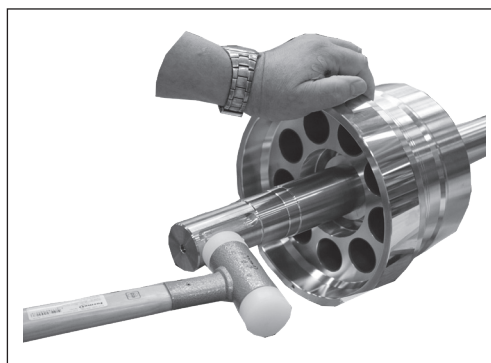

2. Loosen the cone connection by hitting the shaft in radial direction with a soft hammer. If the shaft has to be reused, take care not to damage the shaft.

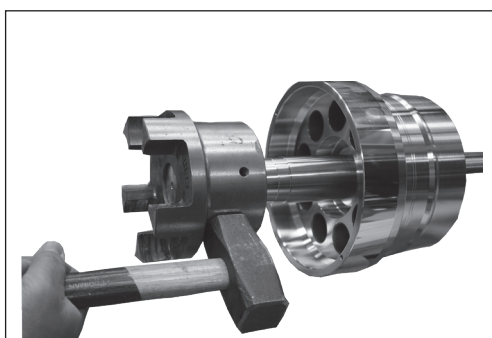

3. Alternatively use the clutch to protect the shaft.

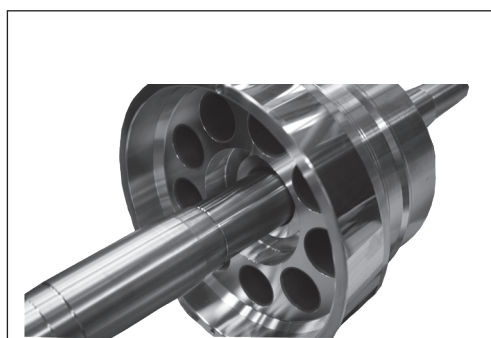

4. The shaft can now be pulled out of the barrel.



5. If there are residues or deposits on the cone surface, gently remove them with a piece of fine sandpaper. Flush with clean water to remove any loose particles before assembling.

5. Assembling shaft and cylinder barrel

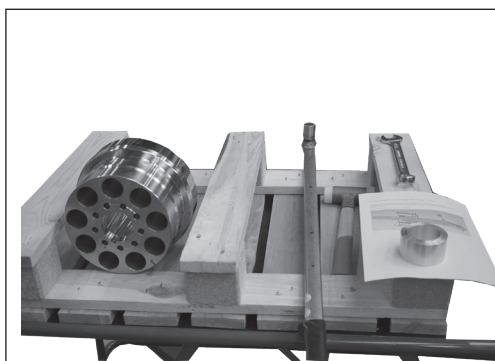

1. Place the cylinder barrel, on a surface, that will not damage or scratch the bearing surface.

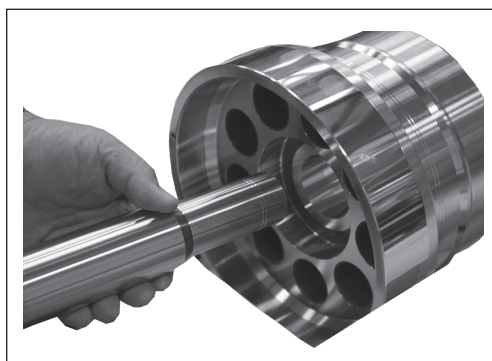

2. Insert the shaft.

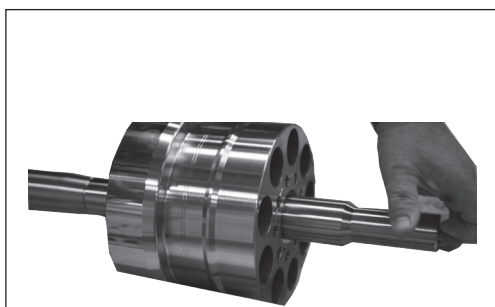

3. Push the shaft through, until the cone connection is reached.

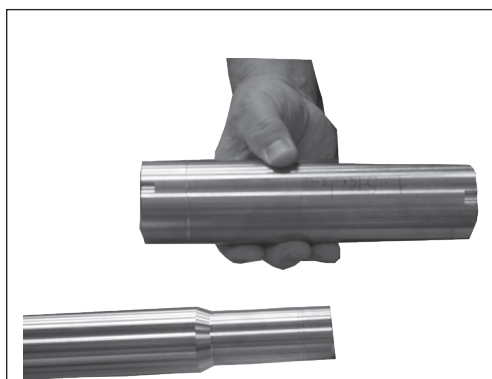

4. Mount the distance tube over the shaft. Use no guide pins.



5. Mount the tool adapter.

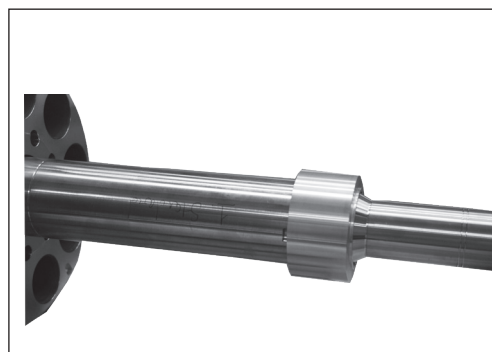

6. Ensure the end with the small lip is pointing away from the distance tube.

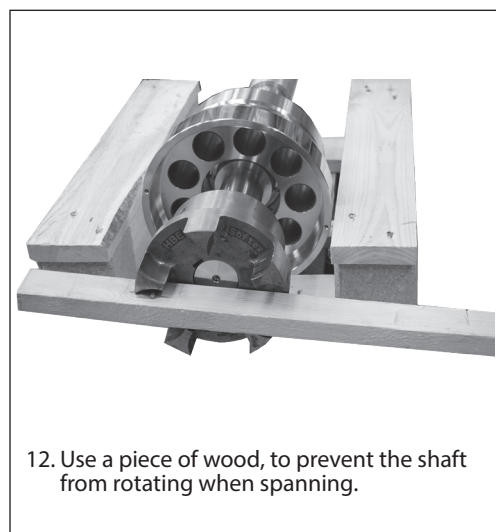
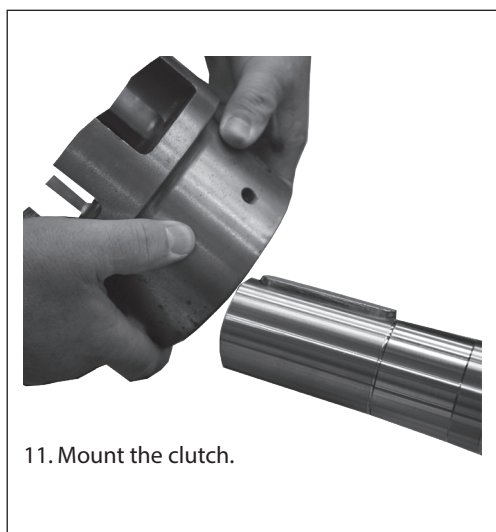
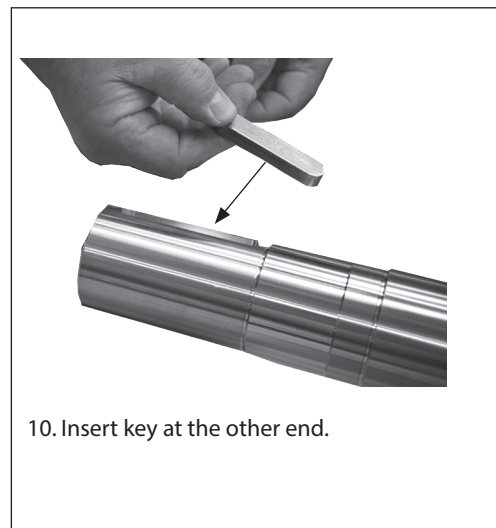
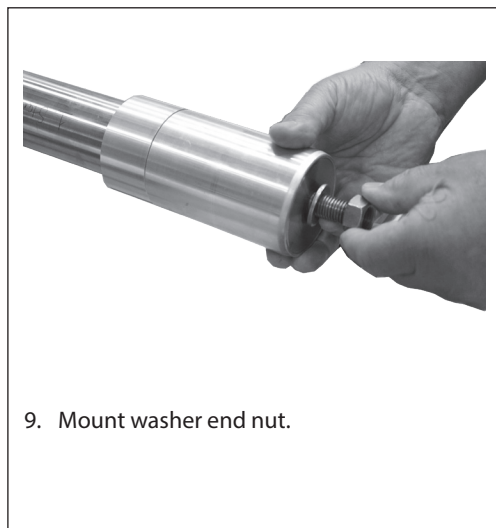
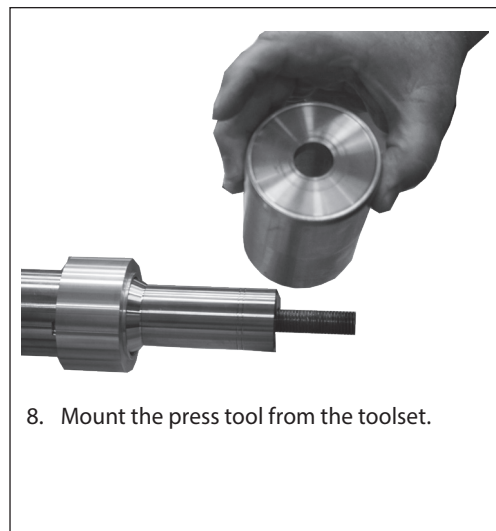
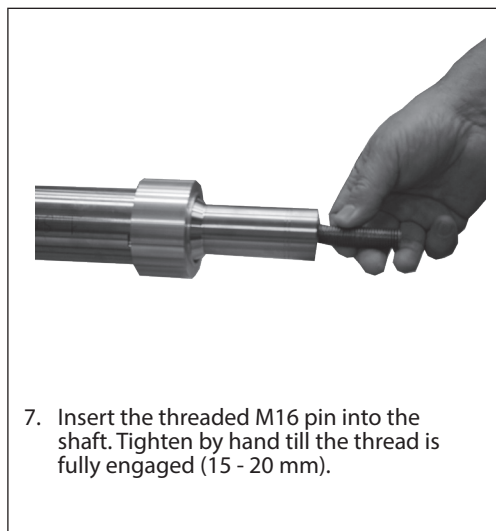

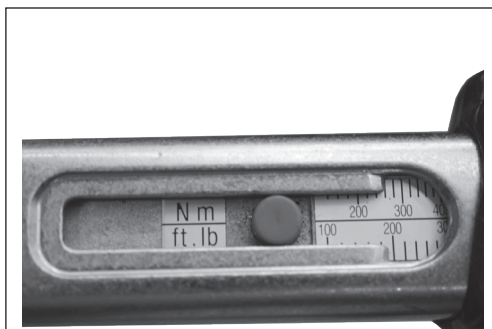

13. Set the torque wrench to 250 Nm.

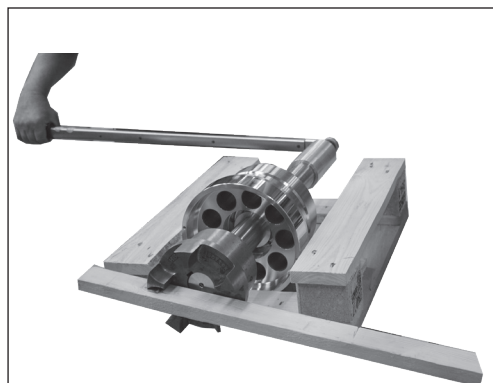

14. Span the nut with 250 Nm, while holding the clutch. Preferably 2 persons is needed to perform the task.

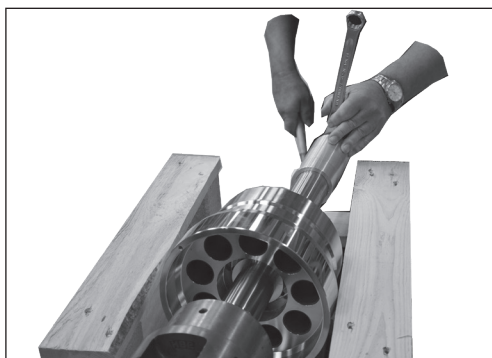

15. Unscrew the nut, and remove clutch, tools and distance tube.

5. Assembling the pump

WARNING:
Do not use silicone when assembling the pump. Do not reuse disassembled O-rings; they might be damaged. Always use new O-rings.

Important:
It is essential that the pump is serviced in conditions of absolute cleanliness. All parts must be absolute clean before mounting.



1. Lubrication:
 - To prevent seizing-up, lubricate all threads with PTFE lubrication type.
 - O-rings inside pump may be lubricated only with clean filtered water.
 - O-rings for port flange, mounting flange and flushing valve must be lubricated.
 - It is important to lubricate ALL parts to be assembled with clean filtered water (Especially all PEEK (plastic) parts).

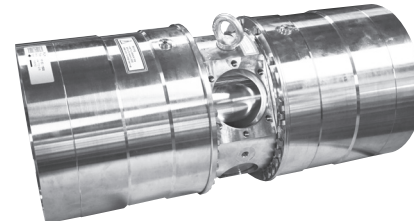

2. Place pump horizontally on a pallet or other stable surface above the ground. Ensure that the pump cannot roll.

Go to the motor flange side (follow arrow on the center flange indicating motor flange side)



3. Mount the port plate guide pins on the center flange.

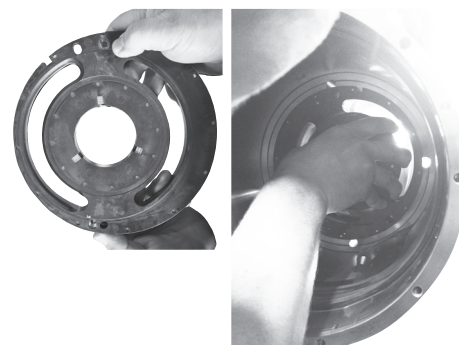

4. Spray center flange with clean filtered water so the port plate sticks to the center flange. Mount the port plate. Notice that the port plate for the motor flange side has additional machined pinholes.

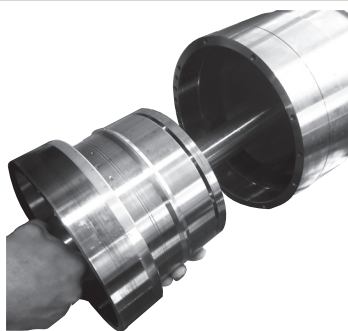

5. Spray with clean filtered water and insert the cylinder barrel with shaft and valve plate.



6. After inserting look through the inlet port and double check that the port plate remains in its position, fit tight between the center flange and the valve plate).

WARNING: Do not scratch the main bearing inside the housing.

Move to end flange side:



7. Screw the bracket in the housing using two treads opposite each other. Screw the bracket to the tread in the shaft. Tighten the nut to the bracket to ensure that the cylinder barrel is fixed and stays in place.

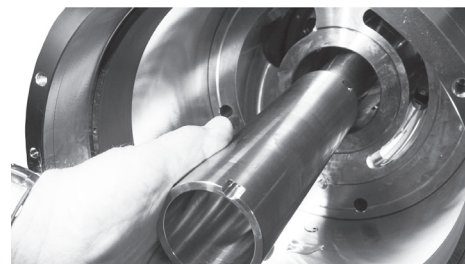

8. Insert the distance pipe. Rotate the distance pipe till the notch finds the guide pin in the cylinder barrel at the opposite side.

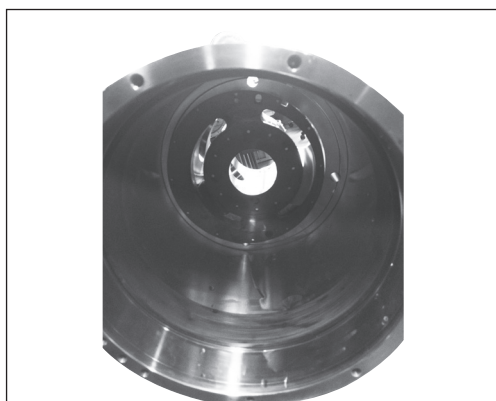

9. Assemble center flange pins and port plate for the motor flange side (as described in step 3 to 4)..



10. Screw the 2 M6 x 65 screws on the cylinder barrel to ease cylinder barrel installation.

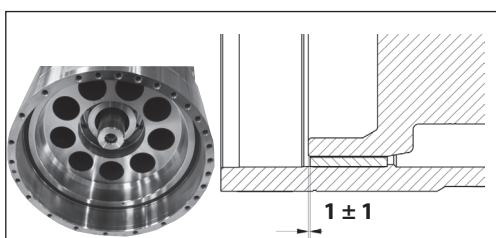

11. Spray with clean filtered water and insert the cylinder barrel. The cylinder barrel fits only in one position because there is a guide pin in the cylinder barrel.

WARNING: The cylinder barrel is well mounted when the main bearing is aligned with the end of the cylinder barrel (see 2D drawing above). Remove the 2 M6 x 65.

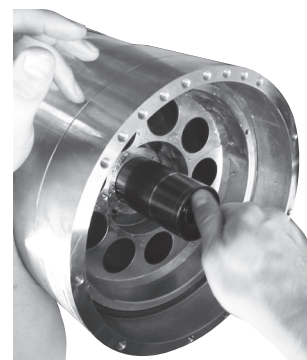

12. Spray the shaft with clean filtered water and mount the cone bushing. Fasten slightly the M16 screw to hold the assembly in place.

Move to motor flange side:

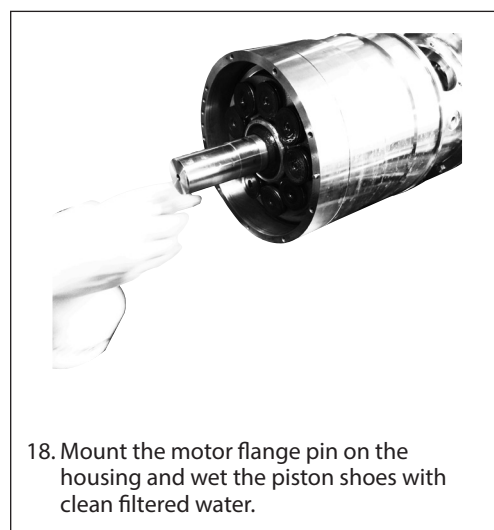
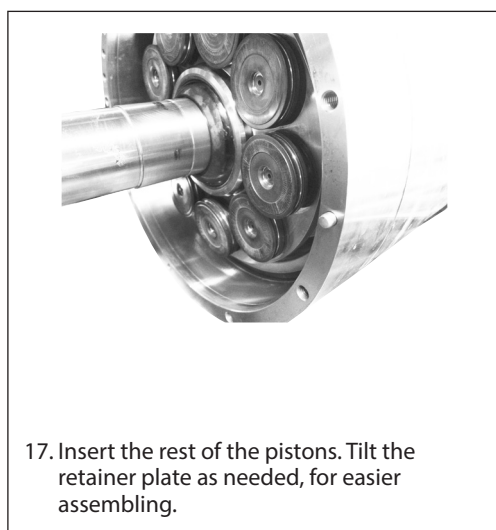
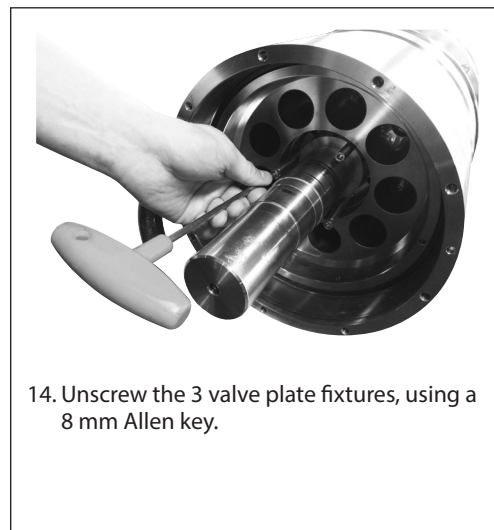
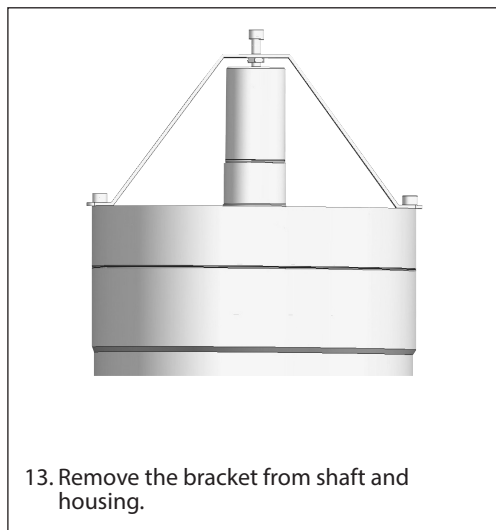



19. Screw the 3 M8x70 screws with nut in three treads so they are equally separated from each other. Torque the screws slightly and fasten the nuts until they make contact with the motor flange.



20. Fasten the 3 nuts one turn at a time to press the motor flange into the housing as straight forward as possible.



21. When the motor flange reaches the housing, the motor flange is on the right position. Mount the rest of the screws, replace the 3 M8x70 with normal screws and fasten all of them according to exploded view using the torque wrench.

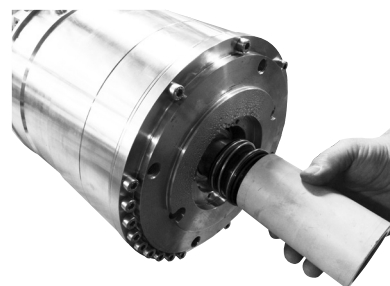

22. Lubricate shaft and shaft seal with clean filtered water. Mount washer for shaft seal. Mount shaft seal and use the shaft seal press bush to press it in.

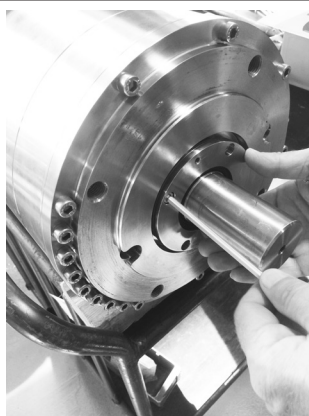

23. Mount cover for shaft seal and torque the 4 M6 screws according to exploded view.

Move to the end flange side:

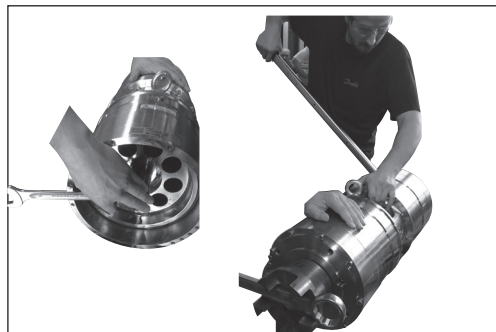

24. Fasten the M16 screw according to exploded view using the torque wrench. To give this torque it will be necessary to lock the shaft so it doesn't turn. Mount the key (only for APP 53 to 86) and the coupling on the motor flange side and use it to lock the shaft.



25. Mount spring package, distance washer, retainer ball, retainer plate and pistons as described before for the motor flange side (steps 14 to 16).

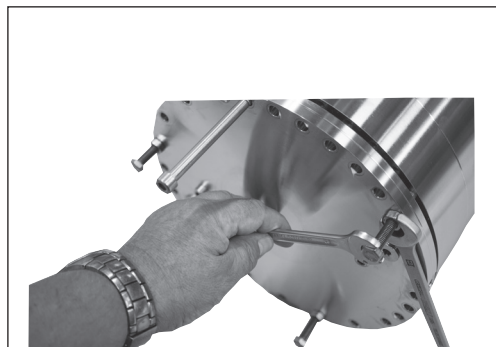

26. Mount the end flange pin and the end flange as described before for the motor flange side (steps 17 to 20).

6. Disassembling and assembling of the flushing valve

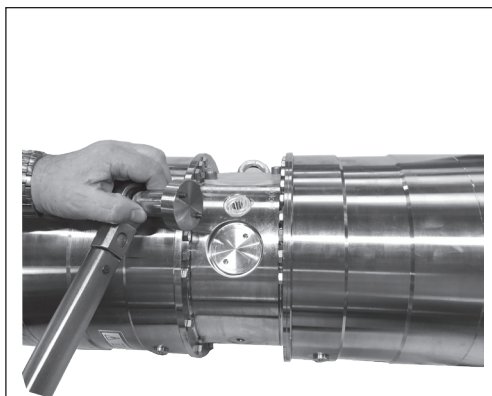

1. Unscrew the flushing valve counterclockwise by using the NV24 tool.

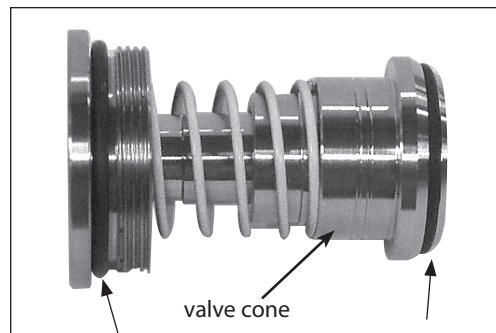

2. Remove the O-rings (green and black). If necessary, change the valve cone, spring and plug. It is important that if the spring is changed it is located like on the picture. The end of the spring must be against the shoulder of the valve cone.

3. Place a bit of grease on the thread on the plug. Screw it into the port flange. Tighten with a torque according to exploded view.

7. Changing pistons

1. Follow disassembly steps 1 to 11 and 17 to 22 for disassembly
2. Follow assembly steps 15 to 21 and 25 to 26 for assembly.

8. Assembling spring package

Assemble the springs symmetrically according to pump size.

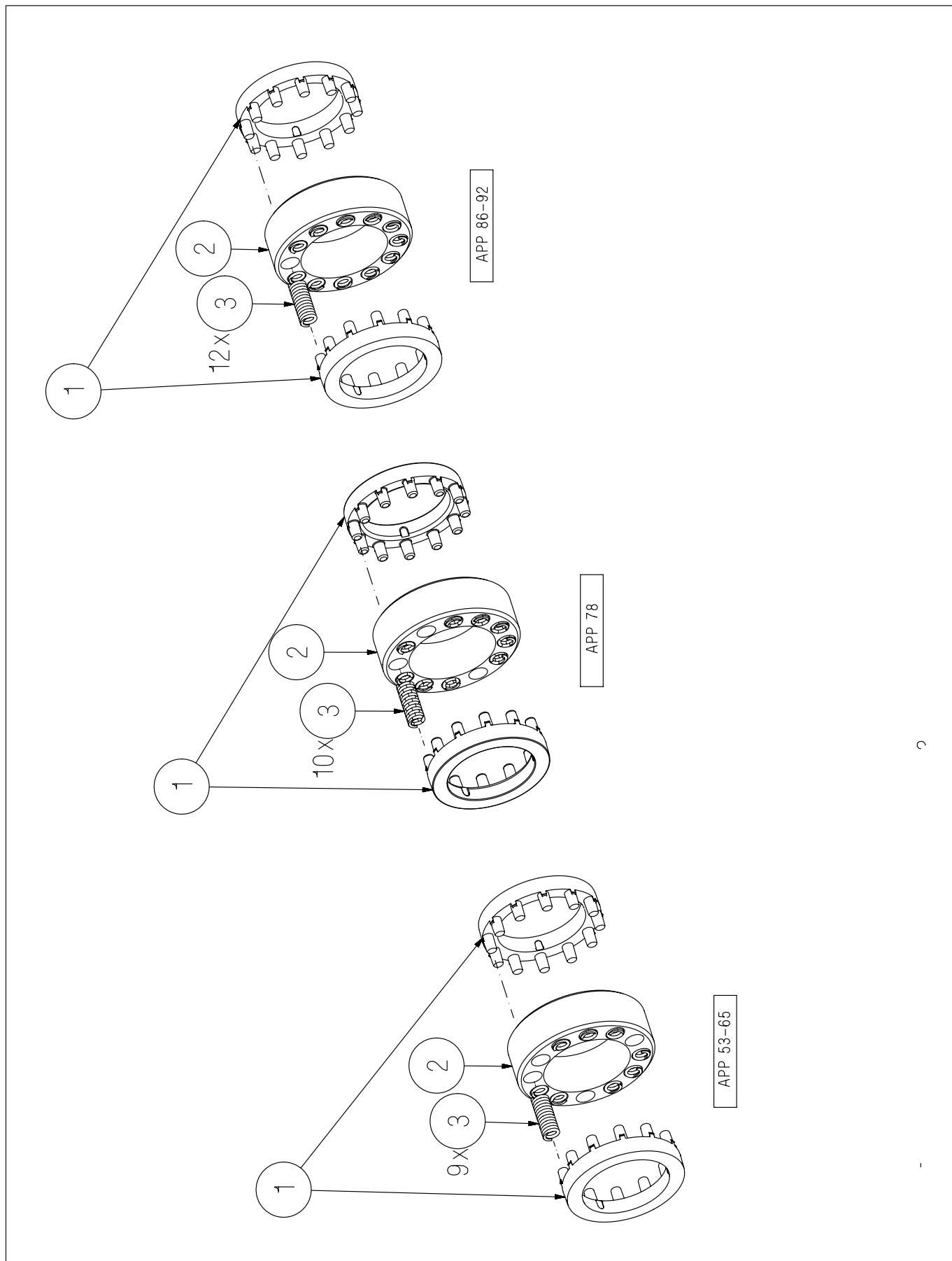

10. When should the pistons be replaced

This section provides guidance on, how to determine whether the parts of the pump are worn and should be replaced. In case of doubt - the pistons must be replaced. The pictures below are meant as a guideline for evaluating the wear of the sliding surface.

Note: If the pistons break down, the pump will suffer a disastrous breakdown.

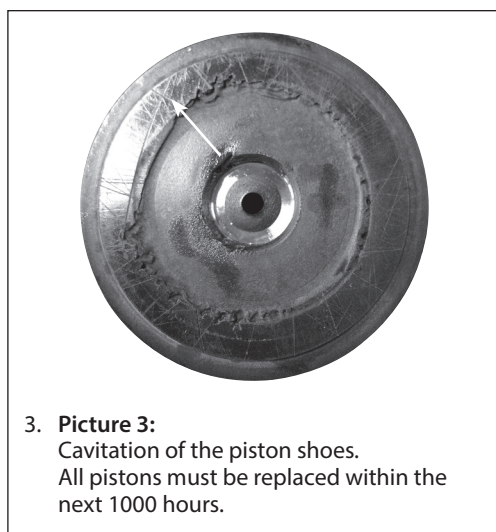
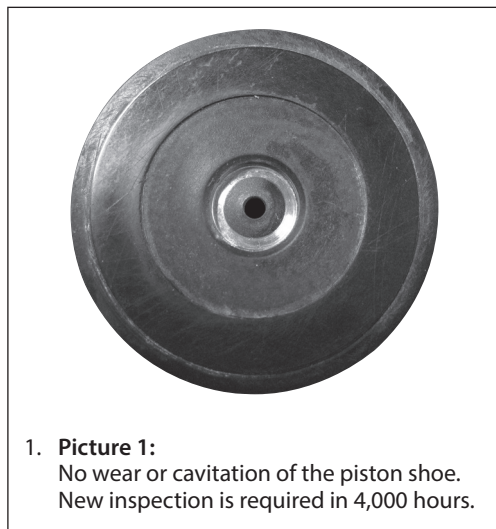

avrora-arm.ru
+7 (495) 956-62-18

ENGINEERING
TOMORROW

