

Data sheet

Rotary position sensor with shaft DST X510



The Danfoss DST X510 rotary position sensors with shaft are designed for use in mobile hydraulic applications.

Danfoss DST X510 series uses contactless Hall technology with measurement ranges up to 360°.

The Sensors are designed for off-highway applications and resistant to shock and vibrations and with high electromagnetic compatibility. They are E1 approved for on-highway applications. They come with either analogue, CANopen or SAE J1939 output.

Single and redundant sensor types are available, making the complete portfolio suitable for safety-critical applications.

Features

- Contactless Hall technology for almost infinite sensor life time
- Single or Redundant ranges up to 360° (±180°)
- Output: Analogue, CANopen and SAE J1939
- Linearity: $< \pm 0.5$ FS
- Resolution:
 - 12 bit (analog)
 - 14 bit (CANopen/SAE J1939)
- IP protection level IP67 - IP69K with female mating connector

Approvals and Conformity

- CE
- RoHS
- E1 approval

Technical data
Performance

Measuring range		360° (±180°)
Linearity		≤ ± 0.5% FS
Resolution and speed of rotation	12 bit (analog output)	120 rpm max.
	14 bit (CANopen/SAE J1939 output)	
Durability (stroke ±75°)		35 M operations

Electrical specifications

Electrical connections	Deutsch 6P DT04-6p or AMP Superseal 6p 282108
Output signal	CANopen / SAE J1939, Ratiometric 10-90% of Vs, 0.5-4.5 Vdc, 0-10 Vdc or 4-20 mA
Supply voltage	CANopen/J1939, 0.5-4.5 Vdc, 4-20 mA; 9-36 VdC; 0-10 Vdc: 11-36 Vdc; Ratiometric: 10-90% of Vs: 5 Vdc
Current consumption	Analogue: < 10 mA/ pr. channel (no load) CANopen/J1939: < 15 mA (no load)
MTTFd [Years]	CANopen/J1939: 336 Analogue: 406 (Single Channel)

Environmental conditions

Operating temperature range		-40 – 85 °C
Thermal drift temperature		< 50 ppm/°C
EMC	Emission	EN 55011 and CISPR 25
	Immunity	EN 61236-3-2 and ISO 11452-2
	Transient on supply lines	ISO 7637-2
	Bulk current injection	ISO 11452-4
Vibration stability	Sinusoidal	20 g, 10 Hz – 2,000 kHz IEC 60068-2-6
Shock resistance	Impulsive on 3 axes	50 g, 11 ms IEC 60068-2-27
IP protection		IP67 - IP69 (with mating connector)

Mechanical characteristics

Materials	Enclosure	PBT (Polybutylene terephthalate)
	Shaft	AISI 316L
Net weight		0.07 kg

Sensor output graph

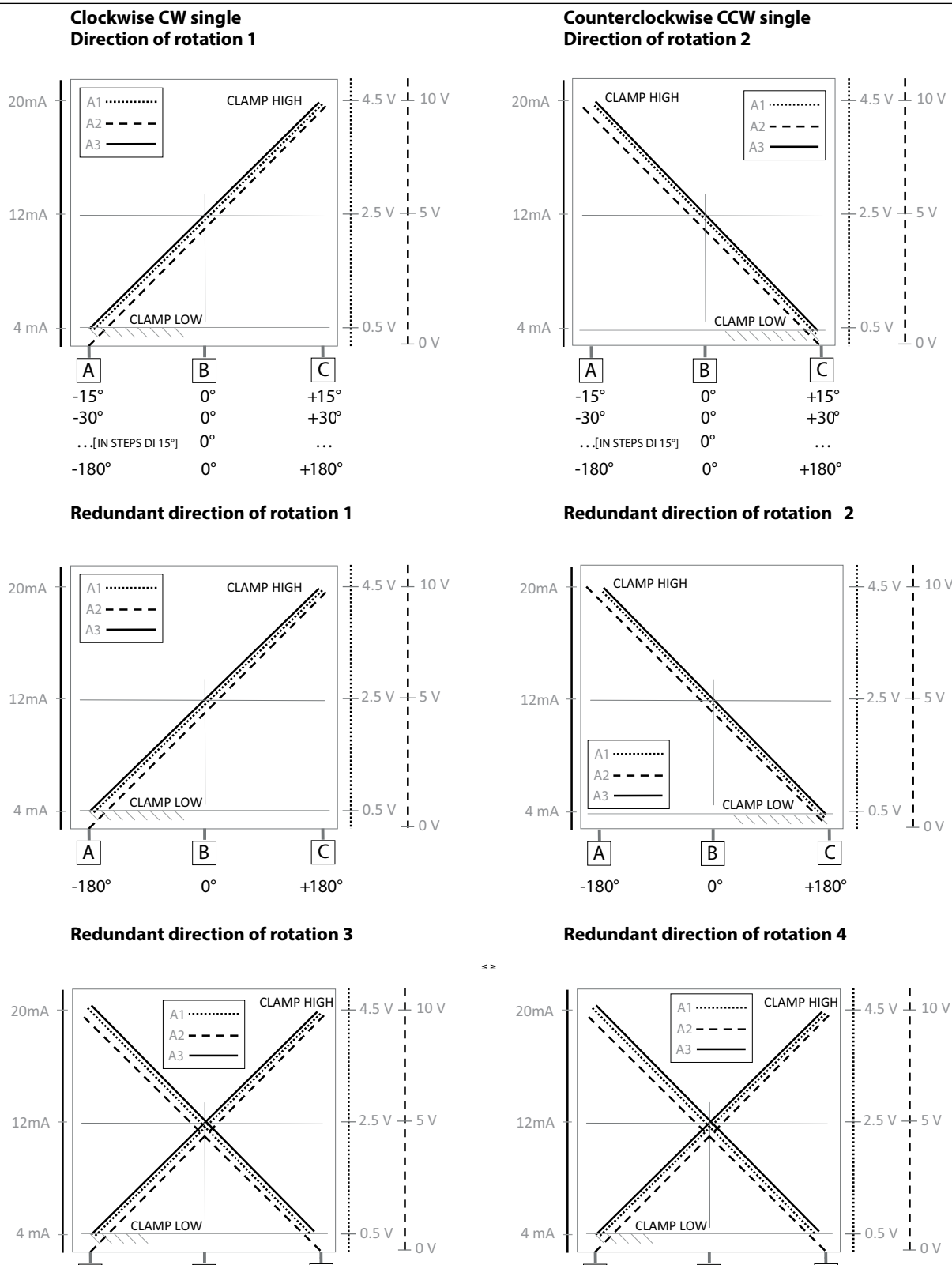

Load conditions

+0.5 Vdc - +4.5 Vdc output with power + 5Vdc: It is recommended a load resistance > 10 kΩ

Data sheet | Rotary position sensor with shaft DST X 510
Ordering standard

Type	Output signal	Configurations	Code no.
DST X 510	5V Ratiometric	±180° Clockwise CW	098G1000
	5V Ratiometric	±180° Counterclockwise CCW/CH2 clockwise CW	098G1001
	36 V CANopen	±180° Clockwise CW	098G1002
	36 V SAE J1939	±180° Clockwise CW	098G1003

Other on request

Ordering code - on request

Electrical connections	
AMP Superseal 6P connector	A
Deutsch 6P connector	D

Circuit type	
Single Analog or CAN/J 1939	S
Redundant Analog	R

Angle/Channel 1 (output for single channel)	
(Analog output A1-A2-A3 programmable in steps of ±15°) (CAN/J 1939 = 180)	xxx

Angle/Channel 2 (redundant versions)	
(Analog output A1-A2-A3 programmable in steps of ±15°) (CAN/J 1939 = 180)	xxx

Supply voltage	
+5Vdc (only for A1 output)	L
+9...+36Vdc (see output signal for right supply voltage)	H

Output type	
+0.5...+4.5Vdc output (available with supply L = ratiometric output and with supply H = 0.5...4.5V output)	A1
0...+10Vdc output (powered at +11...36Vdc)	A2
4...20mA output (powered at +9...36Vdc)	A3
CANopen output (powered at +9...36Vdc) (available in single version with +/-180° measurement range)	C1
SAE J1939 (powered at +9...36Vdc) (available in single version with +/-180° measurement range)	C2

Rotation direction	
Clockwise CW (single) both clockwise CW (redundant or CAN/J1939)	1
Counterclockwise CCW (single) both counterclockwise CCW (redundant or CAN/J1939)	2
CHANNEL 1 clockwise CW and CHANNEL 2 counterclockwise CCW (only for redundant version and CAN/J1939)	3
CHANNEL 1 counterclockwise CCW and CHANNEL 2 clockwise CW (only for redundant version and CAN/J1939)	4

Actuator	
Shaft	A

Reserved	
Always	00

Certificate	
No certificate attached	0
Linearity curve to be attached	L

Version	
Standard	033

Accessories	
No accessories	X
AlSi 304 LEVER	A

Reserved	
Always	00

 Example of ordering:
 DST X510-DS180000HC14A00 0033X00

D	Deutsch 6p
S	Single Analog or CAN/J 1939
180	±180°
000	000
H	+9 - +36 Vdc
C1	CANopen
4	Channel 1: Counterclockwise CCW Channel 2: Clockwise CW
A	Shaft
00	Reserved
0	No certificate
033	Standard
X	No accessories
00	Reserved

Dimensions

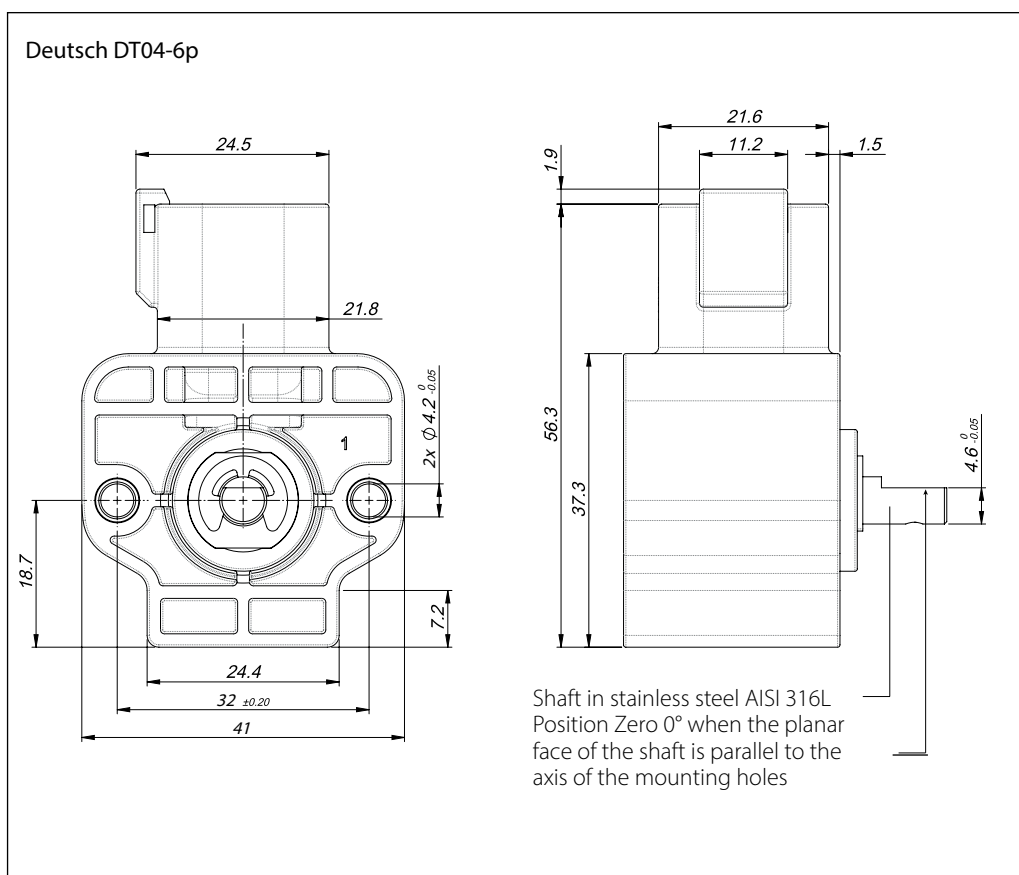

Electrical connections

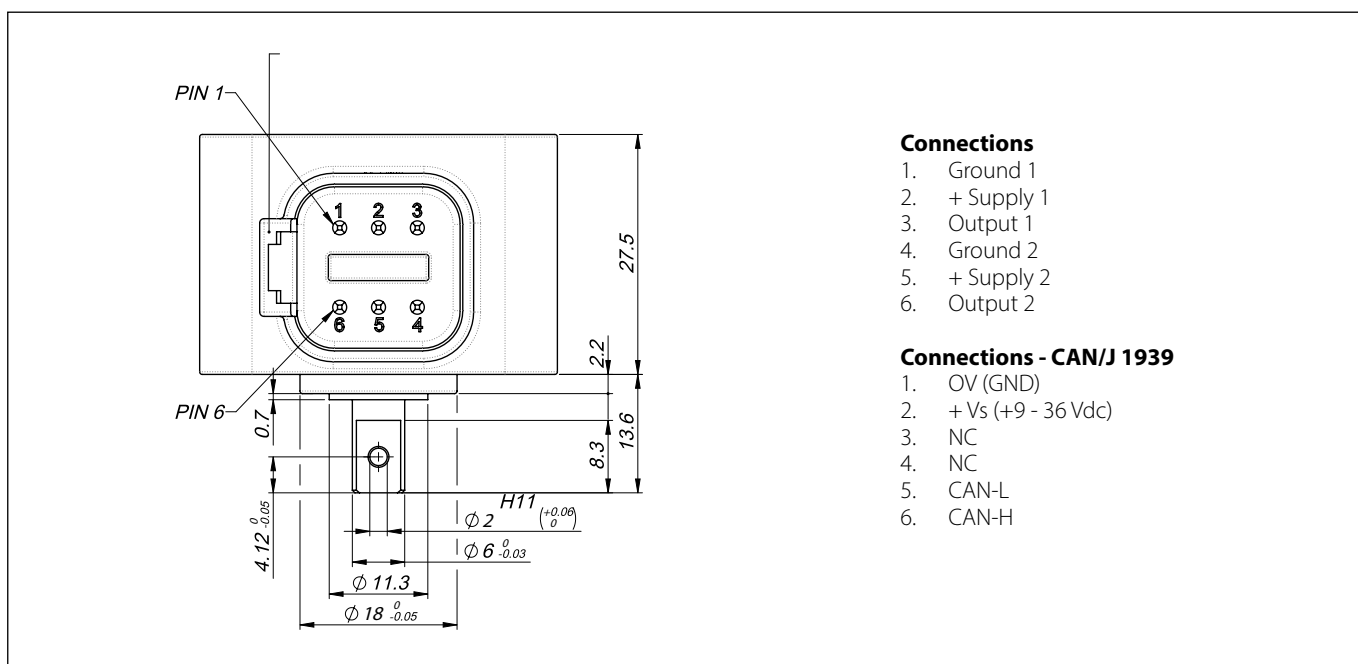
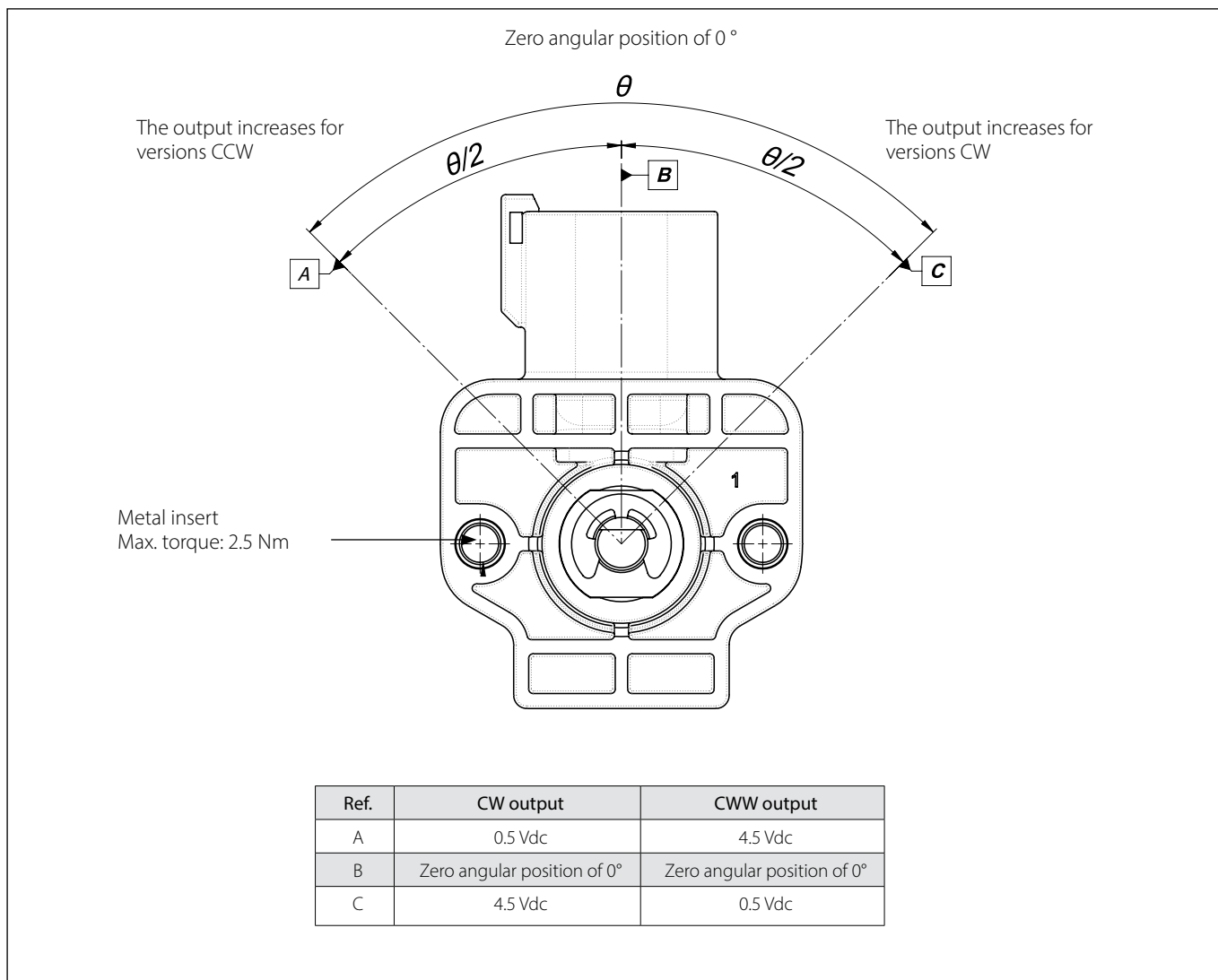

Accessory - Lever

