



Oil Sealed Vacuum Pumps

TRIVAC

Rotary Vane Vacuum Pumps

SOGEVAC

Rotary Vane Vacuum Pumps

VACUBE

Screw Vacuum Pumps

avrorarm.ru
+7 (495) 956-62-18

Contents

Oil Sealed Vacuum Pumps

Rotary Vane Vacuum Pumps TRIVAC	6
General	
Applications for TRIVAC pumps	6
Accessories for TRIVAC pumps	7
Oil for TRIVAC pumps, for different fields of application	8
Oil for TRIVAC pumps, for different pump types	9
Products	
Small Compact Pump S 1,5	10
TRIVAC E, Two-Stage Rotary Vane Vacuum Pump	12
TRIVAC B, Two-Stage Rotary Vane Vacuum Pumps	16
TRIVAC D 4 B and D 8 B	20
TRIVAC D 16 B and D 25 B	24
TRIVAC D 40 B and D 65 B	28
TRIVAC D 16 B-DOT to D 40 B-DOT	32
TRIVAC D 65 B ³ He	36
TRIVAC D 16 B-Ex (Explosion Protected and Pressure Burst Resistant)	38
TRIVAC BCS, Two-Stage Rotary Vane Vacuum Pumps	40
TRIVAC D 16 BCS to D 65 BCS	42
TRIVAC D 16 BCS-PFPE to D 65 BCS-PFPE	46
Motor Dependent Data for the TRIVAC B, BCS and BCS-PFPE	50
Accessories for TRIVAC E, B and BCS	
Global Versions	
Exhaust Filters AF 8 to AF 25	58
Condensate Traps AK 8 to AK 25	58
Exhaust Filters AF 4-8 to AF 40-65	60
Exhaust Filters AF 16-25 DOT and AF 40-65 DOT	60
Exhaust Filters with Lubricant Return	
ARP 4-8 and AR 4-8 to AR 40-65	62
ARS 16-25 and ARS 40-65	63
Exhaust Filter Drain Tap	64
Oil Drain Tap	64
Oil Drain Kit	64
Oil Suction Facility AR-V Controlled by Solenoid Valve	65
Manually Operated Oil Suction Facility AR-M	65
Condensate Separators AK 4-8 to AK 40-65	66
Dust Filters FH/DF, DN 16 KF to DN 40 KF	67
Adsorption Traps FH/RF, DN 16 KF to DN 40 KF	68
Cold Trap TK 4-8	69
Dust Separators AS 8-16 and AS 30-60	70
Molecular Filters MF 8-16 and MF 30-60	70
Mechanical Oil Filters OF 4-25 and OF 40-65	72
Chemical Oil Filters CF 4-25 and CF 40-65	72

Chemical Filters with Safety Isolation Valve CFS 16-25 and CFS 40-65	74
Inert Gas System IGS 16-25 and IGS 40-65	75
Limit Switch System LSS 16-25 and LSS 40-65	76
Roots Pump Adaptor	77
Versions for the North and South American Continents	
SE Smoke Eliminator	78
General Accessories	
Flange Components, Valves	79
Miscellaneous	
Services	80
60 Hz Curves	83
Rotary Vane Vacuum Pumps SOGEVAC	85
General	
Applications for SOGEVAC pumps	85
Oil for SOGEVAC pumps, for different fields of application	86
Oil for SOGEVAC pumps, for different pump types	87
Product Range, Features and Design	88
Products	
SOGEVAC .. B	
SV 10 B / SV 16 B	90
SV 16 D and SV 25 D	92
SV 25 B	96
SV 40 B / SV 65 B	98
SV 100 B	102
SV 120 B	106
SV 200	110
SV 300 B	114
SV 470 B(F) / SV 570 B(F)	118
SV 630 B / SV 630 BF / SV 750 B(F)	122
SV 1200	126
SOGEVAC .. BI	
SV 28 BI	130
SV 40 BI	134
Pumps Prepared with PFPE for Use with Oxygen	136
SOGEVAC .. ATEX	
SV 40 ATEX (Explosion Protected and Pressure Burst Resistant)	138
ATEX Category 2 Pumps	142
ATEX Category 3 Pumps	142

Accessories

Global Versions

Double Inlet Filter and Roots Adapter TwinFilter 500	146
Dust Filters (Suction Side)	150
Dust Filters F (Suction Side) (Version for the North and South American Continents)	152
SL Liquid Traps	154
SEP Separators	156
SEPC Condensers	157
Gas Ballast Valve	158
Thermal Switch	158
Mobile Base Frame	160
Noise Enclosure	162
Mounting Accessories	162
Exhaust Filter Gauge	163
Ball Valves and Valves	164
Bourdon Vacuum Gauges	166
DIAVAC DV 1000	166

Versions for the North and South American Continents

External Carbon Exhaust Filter	167
--------------------------------	-----

Global Versions

Connection Fittings	
for SOGEVAC SV 10 B, SV 16, SV 16 B, SV 16 D, SV 25, SV 25 B, SV 25 D	168
for SOGEVAC SV 40 B, SV 65 B, SV 100 B	170
for SOGEVAC SV 200, SV 300 B	172
for SOGEVAC SV 470 B(F) / SV 570 B(F)	174
for SOGEVAC SV 630 B(F), SV 750 B(F)	176
for SOGEVAC SV 1200	178
60 Hz Curves	180

Special Accessories for Rotary Vane Vacuum Pumps **TRIVAC** and **SOGEVAC**

Versions for the North and South American Continents

Combination Filter, Vacuum Pump Inlet Filter	188
--	-----

Screw Vacuum Pumps VACUBE	190
---	-----

Products

Oil-sealed Screw Vacuum Pumps	190
VACUBE VQ 400 i to VQ 1650 iCH	190

Applications for TRIVAC pumps

Pumps	S 1,5	TRIVAC D 25 E	TRIVAC D 4 B	TRIVAC D 8 B	TRIVAC D 16 B	TRIVAC D 25 B	TRIVAC D 40 B	TRIVAC D 65 B	TRIVAC D 16 B-DOT and D 25 B-DOT	TRIVAC 40 B-DOT	TRIVAC D 65 B ³ He	TRIVAC D 16 B-Ex	TRIVAC D 16 BCS, D 25 BCS	TRIVAC D 65 BCS	TRIVAC D 16 + D 25 BCS-PFPE	TRIVAC D 40 BCS-PFPE	TRIVAC D 65 BCS-PFPE
Applications																	
Production of semiconductors											■	■	■	■	■	■	
Vacuum coating				■	■	■	■						■	■	■	■	■
Research and development	■	■	■	■	■	■	■	■	■				■	■	■	■	■
Chemistry/pharmaceuticals		■		■	■	■	■	■					■	■	■	■	■
Metallurgy/furnaces						■	■										
Lamps and tubes manufacture		■	■	■	■		■	■									
Automotive industry		■		■	■				■	■							
Laser engineering	■																
Space simulation						■	■										
Analytical engineering		■	■	■	■	■											
Environment engineering		■	■	■	■	■	■	■									
Cooling and air-conditioning	■			■	■	■	■	■			■						
Electrical engineering	■	■	■	■	■	■	■	■									
Mechanical engineering	■	■	■	■	■	■	■	■									
Medicine technology		■	■	■	■	■											
Vacuum drying cabinets		■	■	■	■	■											
Chemistry and research labs		■	■	■	■	■							■	■	■		
Freeze drying systems		■	■	■	■	■	■	■									
Backing pump for high vacuum pump systems	■	■	■	■	■	■	■	■					■	■	■	■	■
Leak detectors		■			■	■	■	■									

Accessories for TRIVAC pumps

Pumps	S 1.5	TRIVAC D 2,5 E	TRIVAC D 4 B	TRIVAC D 8 B	TRIVAC D 16 B	TRIVAC D 25 B	TRIVAC D 40 B	TRIVAC D 65 B	TRIVAC D 16 B-DOT + D 25 B-DOT	TRIVAC 40 B-DOT	TRIVAC D 65 B ¹⁾ He	TRIVAC D 16 B-Ex	TRIVAC D 16 BCS + D 25 BCS	TRIVAC D 40 BCS	TRIVAC D 65 BCS	TRIVAC D 16 + D 25 BCS-PPFE	TRIVAC D 40 BCS-PPFE	TRIVAC D 65 BCS-PPFE
Accessories																		
Exhaust filters AF(-DOT)		■	■	■	■	■	■	■	■		■	■	■					
Condensate traps / separators AK	■	■	■	■	■	■	■	■	■		■	■	■	■	■	■	■	■
Exhaust filters with lubricant return ARP / AR			■	■	■	■	■	■	■		■	■	■					
Exhaust filters with lubricant return ARS											■	■	■	■	■	■	■	■
Exhaust filter drain tap		■																
Oil drain tap	■	■	■	■	■	■	■	■	■	■	■	■	■	■	■	■	■	■
Oil drain kit	■	■	■	■	■	■	■	■	■	■	■	■	■	■	■	■	■	■
Oil suction facility AR-V ¹⁾ , magnetic AR-M ¹⁾ , manual		■	■															
Dustfilter FH/DF DN 16 to 40 KF	■	■	■	■	■	■	■	■			■	■	■	■	■	■	■	■
Adsorption trap FH/RF DN 16 to 40 KF	■	■	■	■	■	■	■	■			■	■	■	■	■	■	■	■
Cold trap TK		■	■	■														
Dust separators AS	■	■	■	■	■	■	■	■			■	■	■	■	■	■	■	■
Molecular filters MF	■	■	■	■	■	■	■	■			■	■	■	■	■	■	■	■
Mechanical oil filters OF			■	■	■	■	■	■										
Chemical oil filters CF			■	■	■	■	■	■			■	■	■	■	■	■	■	■
Chemical filters with safety isolation valve CFS		■	■	■	■	■					■	■	■	■	■	■	■	■
Inert gas system IGS											■	■	■	■	■	■	■	■
Limit switch system LSS											■	■	■	■	■	■	■	■
Roots pump adaptor						■	■				■	■			■	■		
Flange components, valves	■	■	■	■	■	■	■	■	■	■	■	■	■	■	■	■	■	■

¹⁾ For pumps with gas ballast only

Oil for TRIVAC pumps for different fields of application

Applications	Semiconductor production	Vacuum coating	Research and development	Chemistry/Pharmaceutical	Metallurgy/Furnaces	Lamps and tubes manufactures	Automotive industry	Laser technology	Space simulation	Analytical engineering	Environment engineering	Oxygen technologies	Cooling and air-conditioning	Electrical applications	Electrical and air-conditioning	Mechanical engineering	Medicine engineering	Vacuum technology	Chemistry and research labs	Freeze drying cabinets	Freeze drying	Backing pump for HV pump systems	Food industry
LEYBONOL Oils																							
LVO 100	▲	■	■	■	■	■	■	■	■	■	■	■	■	■	■	■	●	■	■				
LVO 210		■	■	■	■	■		■	■	■		■	■	■	■	●	■	●	●				
LVO 240			■	■																			
LVO 300																							■
LVO 310			■		■	■	■				■		■										▲
LVO 400	■	●	■	■						■						▲	●		●				
LVO 600			■	■											■								
DOT 4			●				■																

- = Standard
- = Possible
- ▲ = Please contact Leybold

The table only lists general applications. Your specific requirements might be subject to deeper analysis. For further questions, please contact our technical Sales support.

For information on oil specifications please refer to Catalog Part "Oils / Greases / Lubricants "LEYBONOL®".

Oil for TRIVAC pumps for different pump types

Pumps	S 1.5	TRIVAC D 2.5 E	TRIVAC D 4 B	TRIVAC D 8 B	TRIVAC D 16 B	TRIVAC D 25 B	TRIVAC D 40 B	TRIVAC D 65 B	TRIVAC D 16 B-DOT + D 25 B-DOT	TRIVAC 40 B-DOT	TRIVAC D 65 B ³ He	TRIVAC D 16 B/Ex	TRIVAC D 16 BCS + D 25 BCS	TRIVAC D 40 BCS	TRIVAC D 65 BCS	TRIVAC D 16 + D 25 BCS-PFPE	TRIVAC D 40 BCS-PFPE	TRIVAC D 65 BCS-PFPE
LEYBONOL Oils																		
LVO 100	■	■	■	■	■	■	■	■		■	■	■	■	■				
LVO 210	●	●	●	●	●	●	●	●			●	●	●	●				
LVO 240	●	●	●	●	●	●	●	●			▲			●				
LVO 300			●	●	●	●	●	●										
LVO 310	●	●	●	●	●	▲					▲							
LVO 400		▲	▲												■	■	■	
LVO 600	●	●	●	●	●	●	●	●			▲	●	●	●				
DOT 4									■	■								

- = Standard
- = Possible
- ▲ = Please contact Leybold

The table only lists general applications. Your specific requirements might be subject to deeper analysis. For further questions, please contact our technical Sales support.

For information on oil specifications please refer to Catalog Part "Oils / Greases / Lubricants LEYBONOL®".

Products

Small Compact Pump S 1,5

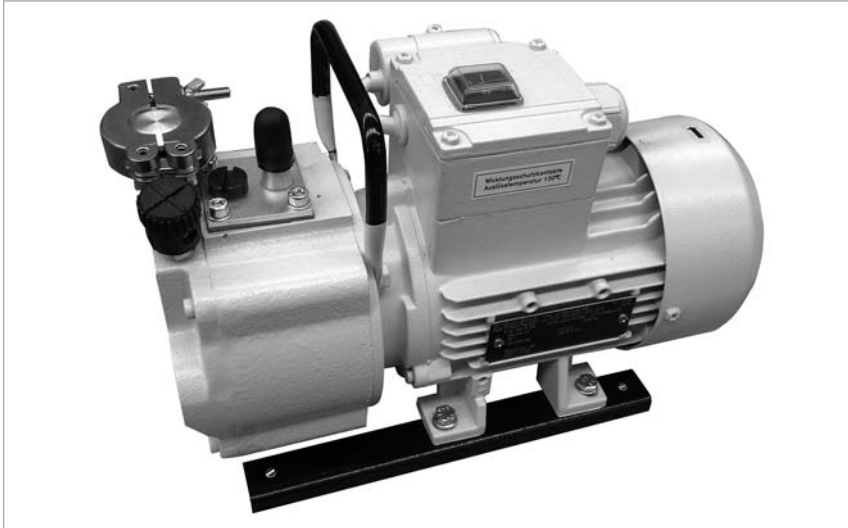

The S 1,5 is a single-stage, oil sealed rotary vane pump with a gas ballast valve. It is driven by a flange mounted AC motor. The shaft of the pump and the shaft of the motor are linked by means of a pinned coupling.

Advantages to the User

- Very small and light-weight
- Low ultimate pressure
- High water vapor tolerance
- Low noise operation
- Simple to connect
- Easy to maintain and use

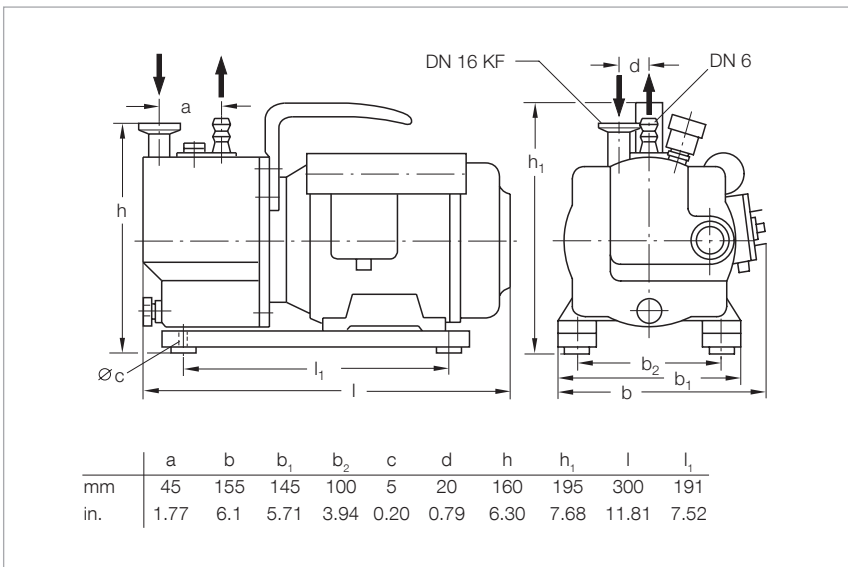

Dimensional drawing for the S 1,5

Typical Applications

- In all areas of vacuum engineering where a low intake pressure is required
- Evacuation of refrigerant circuits
- For suction, lifting, emptying, filling and tensioning
- For installation in mobile instruments

Supplied Equipment

- DN 16 small flange connection on the intake side
- Centering ring and clamping ring
- Exhaust port designed as a DN 6 hose nozzle
- Carrying handle
- Built-in ON/OFF switch and overcurrent circuit breaker
- Oil filling

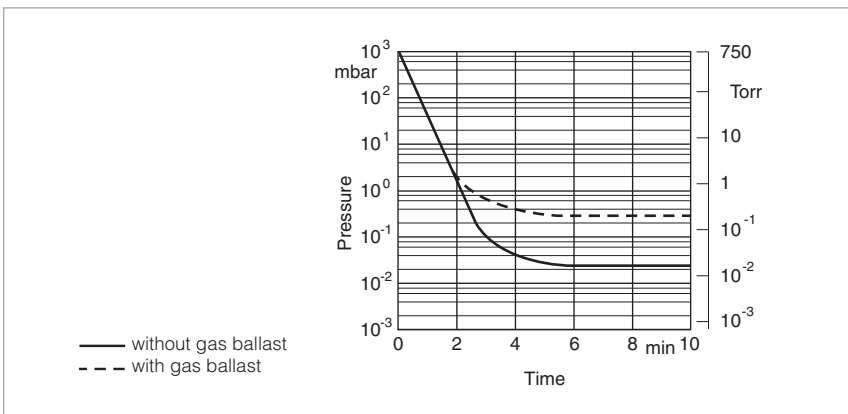

Pump-down characteristics of a 10 l vessel at 50 Hz

Technical Data

S 1,5

		50 Hz	60 Hz
Nominal pumping speed ¹⁾	m ³ /h (cfm)	1.9 (1.1)	2.3 (1.3)
Pumping speed ¹⁾	m ³ /h (cfm)	1.75 (1)	2.1 (1.2)
Ultimate partial pressure without gas ballast ¹⁾	mbar (Torr)	3 x 10 ⁻² (2.3 x 10 ⁻²)	3 x 10 ⁻² (2.3 x 10 ⁻²)
Ultimate total pressure with gas ballast ¹⁾	mbar (Torr)	5 x 10 ⁻¹ (3.8 x 10 ⁻¹)	5 x 10 ⁻¹ (3.8 x 10 ⁻¹)
Water vapor tolerance ¹⁾	mbar (Torr)	> 15 (> 11.3)	> 15 (> 11.3)
Water vapor capacity	g/h (lbs/h)	19 (42)	23 (50)
Oil filling, min. / max.	l (qt)	0.11/0.14 (0.12/0.15)	0.11/0.14 (0.12/0.15)
Noise level to DIN 45 635	dB(A)	50	50
Admissible ambient temperature	°C (°F)	12 - 40 (53.6 -104)	40 (53.6 -104)
Max. permanent inlet pressure	mbar (Torr)	30 (22.5)	30 (22.5)
Motor rating	W (hp)	80 (0.11)	80 (0.11)
Nominal speed	rpm	1500	1800
Weight	kg (lbs)	8.8 (19.4)	8.8 (19.4)
Connections			
Intake	DN	16 KF	16 KF
Exhaust		6 mm hose nipple	6 mm hose nipple

Ordering Information

S 1,5

	Part No.
S 1,5 with AC motor, 230 V (208 - 252 V ± 5%), 50/60 Hz, with 2 m long mains cord and EURO plug	101 01
Transition connector (250 V AC, 10 A, L+N+PE) only necessary in Switzerland for 1~ pumps	800 001 274
AK 8 condensate trap	190 60
Exhaust filter drain tap (G 1/4")	190 95
Connection components	
Elbow (1x) DN 16 KF	184 36
Centering ring with O-ring (2x) DN 16 KF	183 26
Clamping ring (2x) DN 16 KF	183 41

¹⁾ To DIN 28 400 and following numbers

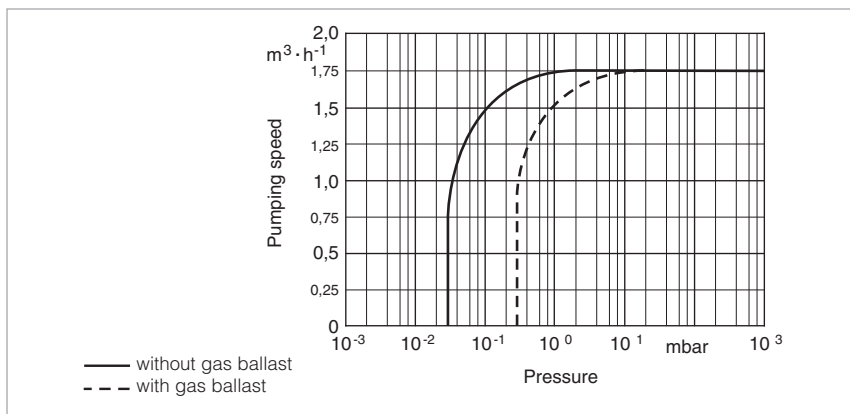

Pumping speed characteristics at 50 Hz

TRIVAC E, Two-Stage, Oil Sealed Rotary Vane Vacuum Pump



TRIVAC D 2,5 E

The TRIVAC E pump is an oil sealed vacuum pump operating according to the rotary vane principle. Oil which is injected into the pump chamber is used for sealing, lubrication and cooling purposes.

The result is the TRIVAC E rotary vane vacuum pump.

Beyond the usual quality and reliability of the B series pumps, the TRIVAC E pump offers improvements in the area of quieter operation, smaller size and improved service-friendliness.

The intake and exhaust ports are equipped with small flanges. Besides standard voltages and frequencies, Leybold offers world motors, which are specially required by OEMs.

Advantages to the User

- Highly reliable
- Small and compact
- Quiet operation
- Environmentally compatible (low oil consumption, EMI compatible; IP 54 protection)
- Process quality (low backstreaming of oil)
- Motor for all standard supply voltages and frequencies
- Safe and intelligent vacuum protection (hermetically sealed)
- Free of yellow metals
- Compliance with international standards (CE)
- Suitable for continuous operation at 1000 mbar (750 Torr)
- Low power consumption
- Better individual performance given by 3 stage gas ballast device
- High water vapor tolerance
- Simplified customizing ability

Typical Applications

- Mass and X-ray spectrometers
- Electron beam microscopes
- Leak detectors
- Sterilizers
- Freeze-drying systems
- Chemical and research labs
- General vacuum engineering
- Backing pump for high vacuum pump systems

Supplied Equipment

- Dirt trap
- Oil filling included separately (standard LVO 100)
- Gas ballast device
- Mains cord with the specific plug for EURO, US and Japan motors
- Optional: Mains cord with country specific plug for the world motor
- With handle

All pumps are 100% subjected to a vacuum test before delivery!

TRIVAC D 2,5 E

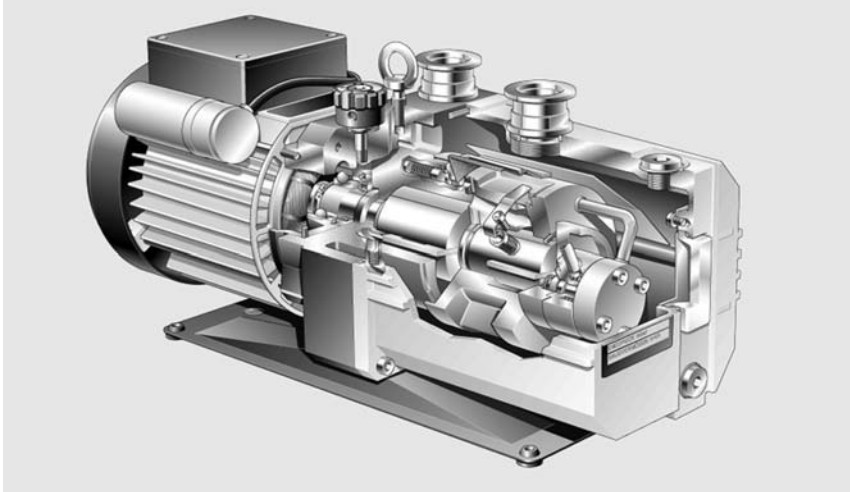

TRIVAC E

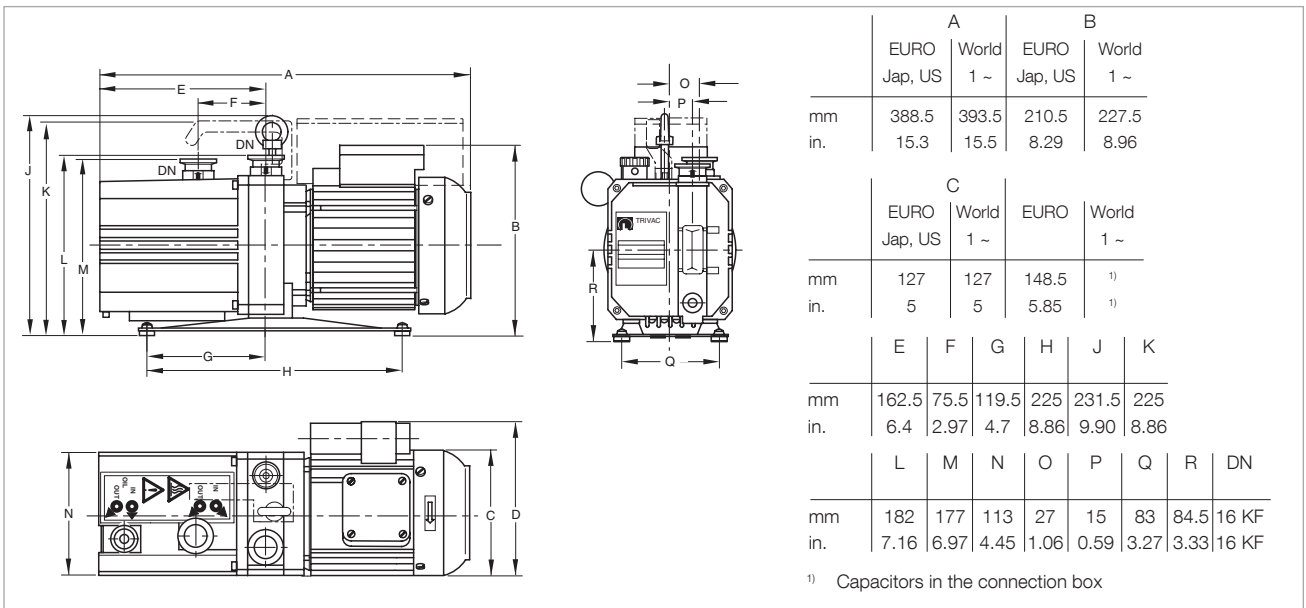

Dimensional drawing for the TRIVAC D 2,5 E

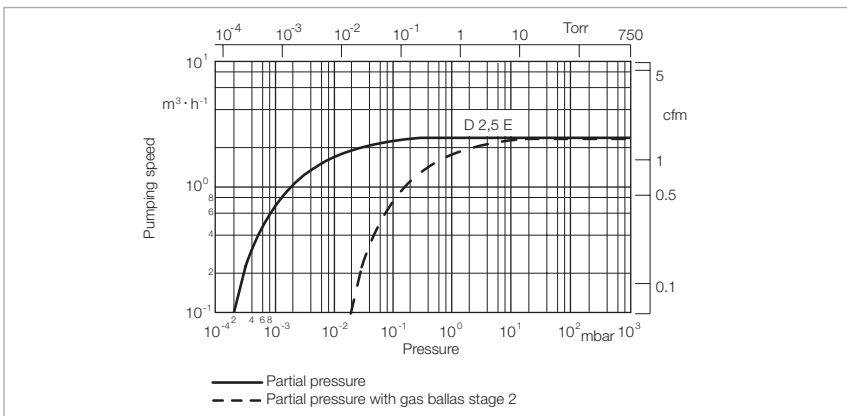

Pumping speed of the TRIVAC D 2,5 E at 50 Hz (60 Hz curves at the end of the chapter)

Technical Data

TRIVAC D 2,5 E

		50 Hz	60 Hz
Nominal pumping speed ¹⁾	m ³ /h (cfm)	3.2 (1.9)	3.6 (2.1)
Pumping speed ¹⁾	m ³ /h (cfm)	2.7 (1.6)	3.3 (1.9)
Ultimate partial pressure without gas ballast	mbar (Torr)	≤ 5 × 10 ⁻⁴ (≤ 3.8 × 10 ⁻⁴)	≤ 5 × 10 ⁻⁴ (≤ 3.8 × 10 ⁻⁴)
Ultimate total pressure without gas ballast ²⁾	mbar (Torr)	≤ 2 × 10 ⁻³ (≤ 1.5 × 10 ⁻³)	≤ 2 × 10 ⁻³ (≤ 1.5 × 10 ⁻³)
Ultimate total pressure with gas ballast Stage 2 ²⁾	mbar (Torr)	≤ 3 × 10 ⁻² (≤ 2.3 × 10 ⁻²)	≤ 3 × 10 ⁻² (≤ 2.3 × 10 ⁻²)
Water vapor tolerance			
Stage 1	mbar (Torr)	10 (7.5)	10 (7.5)
Stage 2	mbar (Torr)	20 (15)	20 (15)
Stage 3	mbar (Torr)	30 (22.5)	30 (22.5)
Water vapor capacity			
Stage 1	g/h (lbs/h)	20 (0.044)	25 (0.055)
Stage 2	g/h (lbs/h)	40 (0.088)	50 (0.110)
Stage 3	g/h (lbs/h)	60 (0.132)	75 (0.165)
Oil filling, min. / max.	l (qt)	0.4 / 0.7 (0.42 / 0.74)	0.4 / 0.7 (0.42 / 0.74)
Noise level	dB(A)	≤ 47	≤ 49
Admissible ambient temperature	°C (°F)	+10 to +50 (+50 to +122) (EURO motor) / +10 to +40 (+50 to +104) (US/Japan motor)	+10 to +50 (+50 to +122) (EURO motor) / +10 to +40 (+50 to +104) (US/Japan motor)
Motor rating	W (HP)	250 (0.34)	300 (0.41)
Nominal speed	rpm	1400	1600
Type of protection	IP	54	54
Weight (with oil filling)	kg (lbs)	16.1 (35.4)	16.1 (35.4)
Connections (Intake and Exhaust)	DN	16 KF	16 KF

¹⁾ To DIN 28 426 T1

²⁾ To DIN 28 400 and following numbers

Motor Dependent Data

Motors for D 2,5 E	Voltage (V)	Frequency (Hz)	Voltage tolerance	Power consumption (W (HP))	Nominal current (A)	Protection	Nominal speed (rpm)
EURO 1 ~	220-240/230	50/60	± 5%	250/300 (0.34/0.41)	1.8/1.4	IP 54	1400/1600
World 1 ~	100-120 200-240	50/60	± 5%	250/300 (0.34/0.41)	4.4/3.0 2.2/1.5	IP 54	1400/1600

Ordering Information

TRIVAC D 2,5 E

	Part No.
TRIVAC E with 1.8 m (6 ft.) long mains cord EURO version, 1-ph., 220-240 V, 50 Hz; 230 V, 60 Hz	
Schuko plug	140 000
CH plug	140 005
Single phase world motor, 100-120 V, 200-240 V 50/60 Hz (without mains cord)	140 001
Further variants upon request	
Accessories	
Connection cable for single phase world motor	
230 V Schuko plug	200 81 091
230 V UK plug	200 81 097
230 V CH plug	200 81 099
230 V NEMA plug (200-240 V)	200 81 141
115 V NEMA plug (100-120 V)	200 81 090
Exhaust filter AF 8	190 50
Replacement filter elements FE 8 for AF 8 (pack of 5)	190 80
Exhaust filter drain tap (G 1/4")	190 95
Manual oil return AR-M via gas ballast inlet (kit for AF 8-16)	190 93
Oil suction AR-V controlled by a solenoid valve via the gas ballast inlet (kit for AF 8-16)	190 92
Condensate trap AK 8	190 60
Oil drain tap (M 16 x 1.5)	190 90
Oil drain kit (M 16 x 1.5)	190 94
Connection components	
Elbow (1x) DN 16 KF	184 36
Centering ring with O-ring (2x) DN 16 KF	183 26
Clamping ring (2x) DN 16 KF	183 41
Spare Parts	
Maintenance kit 1 (oil demister, oil box seal)	200 40 022
Repair kit 1 (motor side sealing, shaft sealing ring, coupling sleeves, compression spring)	E 100 000 351
Repair kit 2 (valves, oil demister, oil box seal)	200 40 024
Repair kit 3 (oil demister, sealing, wearing parts)	E 100 000 347
For further accessories see Chapter "Accessories for TRIVAC E, B and BCS"	

TRIVAC B, Two-Stage Rotary Vane Vacuum Pumps TRIVAC D 4 B to D 65 B

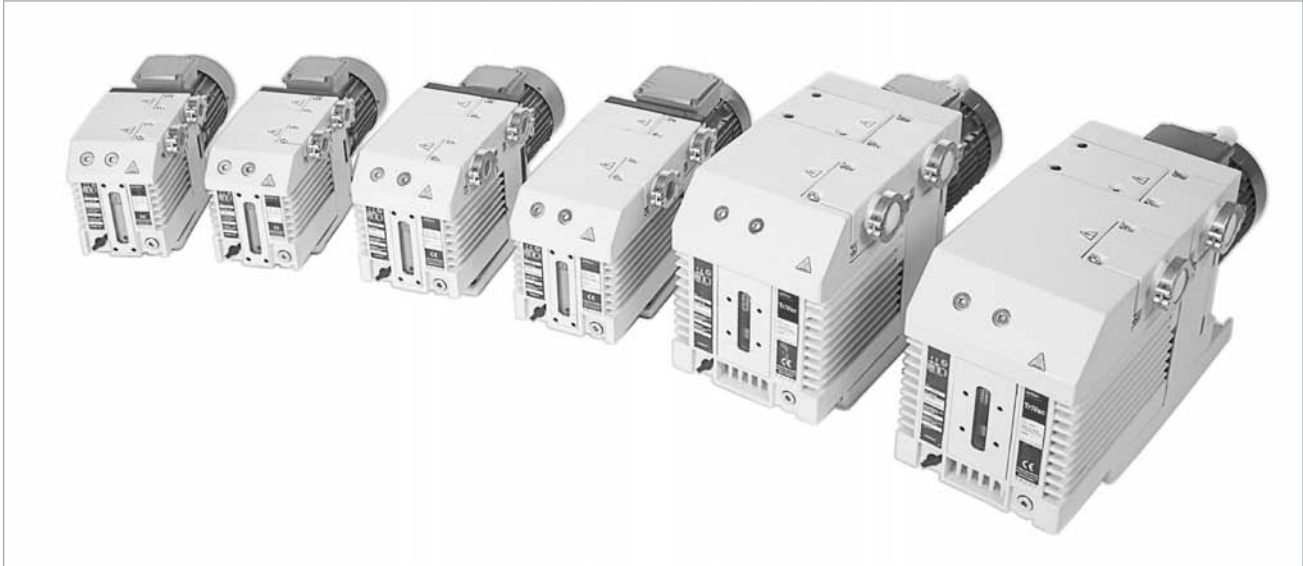

The TRIVAC B is part of the well-proven TRIVAC concept.

The TRIVAC B pumps with their comprehensive range of accessories have proven themselves time and again as rugged pumps in many and varied applications.

The inner body is assembled from individual parts without sealing components. The parts are pinned in order to ensure easy disassembly and reassembly of the parts.

All pumps from the D 4 B to the D 25 B model are equipped either with single-phase or three-phase motors. D 40 - 65 B models are equipped with three-phase motors. In the TRIVAC B, the pump unit and the motor are linked by an elastic coupling.

The TRIVAC B range is a modular system which divides into three groups:

TRIVAC 4/8 Series
TRIVAC 16/25 Series
TRIVAC 40/65 Series

Advantages to the User

- All basic models (single-phase and three-phase motor) are certified in accordance with 94/9/EG (ATEX) (Category 3 inside)
- High water vapor tolerance
- Continuous operation even at 1000 mbar
- Built-in oil pump; pressure-lubricated sliding bearings
- All controls as well as the oil sight glass are located on the front face
- Either vertical or horizontal intake and exhaust ports
- Exchangeable inner body
- Anti-suckback valve controlled via the oil pressure
- Free of yellow metals
- Service-friendly
- Ideal as backing pump for medium and high vacuum applications, because of low oil backstreaming
- Highly leaktight (⁴He-capable)

Typical Applications

See chapter "General, Applications and Accessories".

Supplied Equipment

Small flanges, centering and clamping rings. The intake flange contains a dirt trap.

A carrying handle is standard for all pumps up to the D 25 B. TRIVAC B pumps with single-phase motors are delivered with ON/OFF switch, mains cord and main plug, ready for immediate operation.

Standard TRIVAC B pumps come with a filling of oil LEYBONOL LVO 100, others with special oil fillings can be specified.

All pumps are 100% subjected to a vacuum test before delivery!

Custom Models

- ATEX (Category 3 inside and 3 outside)
- Brake fluid
- Oils for refrigerating machines, e.g. ester oils for refrigerant circuits with R 134 a
- Pressure burst resistant (for the new refrigerants propane and isobutane)
- ³He-tight (for cryostats)
- Special motors

TRIVAC D 16 B-DOT to D 40 B-DOT

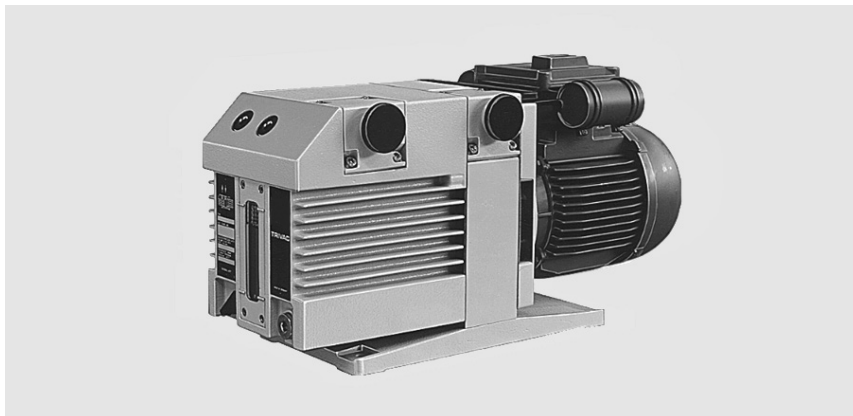

The TRIVAC B-DOT pumps operate with brake fluid (DOT 4) as the sealing and lubricating agent. Therefore these pumps are equipped with EPDM seals. EPDM is highly compatible with brake fluid.

Advantages to the User

- Matching exhaust filters with EPDM gaskets (AF-DOT)
- Except for the seals and the fluid the TRIVAC B-DOT pumps are identical to the oil sealed TRIVAC B pumps

Typical Applications

- For filling of brake fluid circuits in the automotive industry

Supplied Equipment

- The brake fluid is inside the pump when shipped

TRIVAC D 65 B ³He



Advantages to the User

- Leak rates below 1×10^{-7} mbar x l/s, also while the pump is running
- Low pressures of 100 mbar in the oil box are permitted during operation
- No gas ballast facility
- Pump is FPM (FKM)-sealed

Typical Applications

- Pumping of continuously or discontinuously ³He operated cryostats, also on ³He and ⁴He mixed cryostats
- In these cryostats the very expensive helium isotope ³He, respectively mixtures consisting of ³He and ⁴He are pumped and this is generally done continuously in cycles running over weeks. The gas must neither be lost nor contaminated. For this reason exhaust lines are frequently operated at low pressures of 100 mbar (absolute)

TRIVAC D 16 B-Ex, Explosion Protected and Pressure Burst Resistant

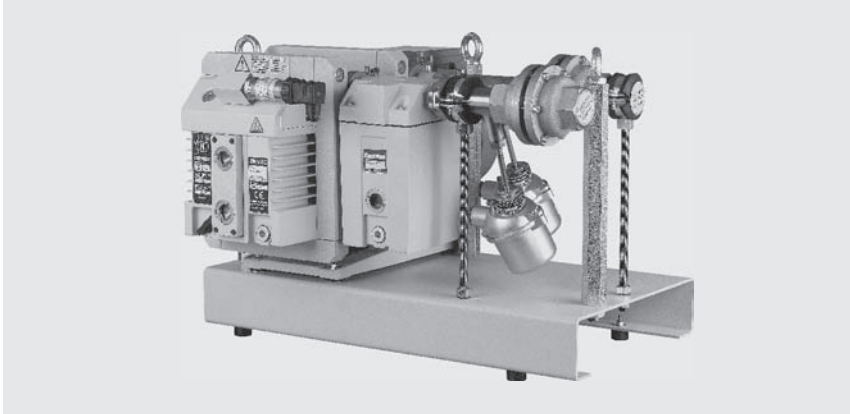

ATEX

**Category 1 inside and
2 outside**

Typical Applications

- Pumping of gases belonging to Group IIB3 and IIC ¹⁾ from Zone 0

Vacuum pumps TRIVAC D 16 B-Ex meet the requirements of the European Directive 94/9/EG (ATEX Directive). TRIVAC D 16 B-Ex pumps are classified inside as Category 1, outside as Category 2. Thus these pumps are suited for pumping explosive gases from Zone 0, the pump itself may be located in Zone 1.

The vacuum pumps TRIVAC D 16 B-Ex are qualified for gases of Explosion Groups IIC ¹⁾ and IIB3. The temperature class is T4. TRIVAC D 16 B-Ex pumps are explosion resistant and correspond to the state-of-the-art. They are equipped as standard with one each temperature sensor on the intake and delivery side.

Moreover, the pressure inside the pump is monitored. Flame arresters on the intake and delivery side protect the upstream and downstream system sections. Also provided as standard is an exhaust filter for every pump.

¹⁾ With the exception of acetylene and carbon bisulphide

TRIVAC D 4 B and D 8 B



TRIVAC D 4 B (left) and TRIVAC D 8 B (right)

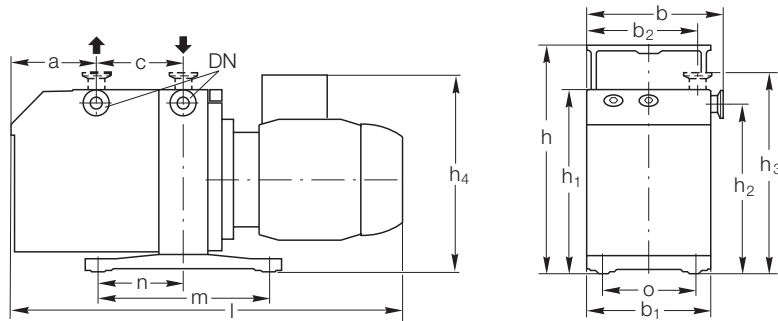

Type	DN		a	b	b ₁	b ₂	c	h	h ₁	h ₂	h ₃	h ₄ ¹⁾	l ¹⁾	m	n	o
D 4 B (Part No. 112 45)	16 KF	mm	75	162	147	132	100	265	215	200	230	234	441	198	99	108
		in.	2.95	6.38	5.79	5.23	3.94	10.43	8.46	7.87	9.06	9.21	17.36	7.80	3.90	4.25
D 8 B (Part No. 112 55)	16 KF	mm	100	162	147	132	100	265	215	200	230	234	465	198	99	108
		in.	3.94	6.38	5.79	5.23	3.94	10.43	8.46	7.87	9.06	9.21	18.31	7.80	3.90	4.25

¹⁾ For dimensions h₄ and l for further part numbers, see paragraph "Motor Dependent Data for the TRIVAC B, BCS and BCS-PFPE"

Dimensional drawing for the TRIVAC D 4 B and D 8 B

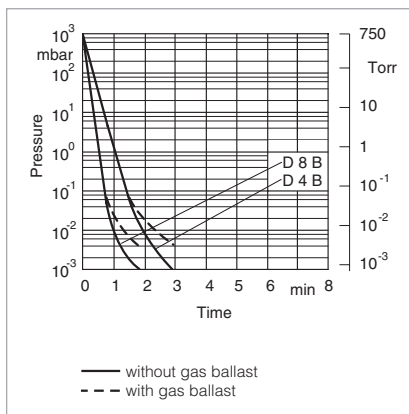

Pump-down characteristics of a 10 l vessel at 50 Hz

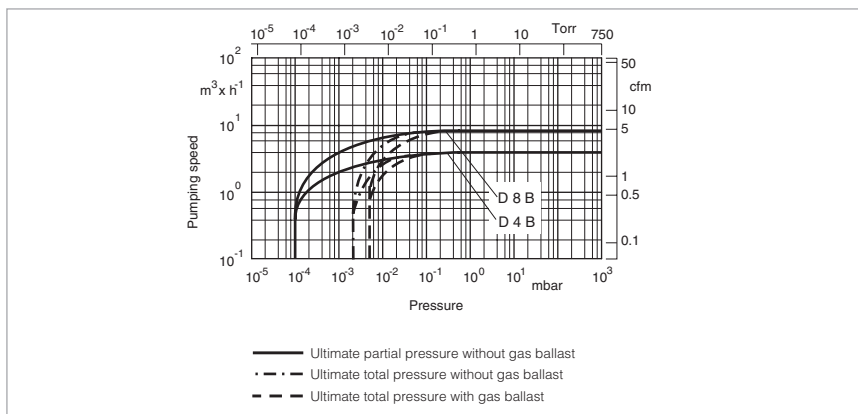

Pumping speed characteristics at 50 Hz (60 Hz curves at the end of the chapter)

Technical Data

TRIVAC D 4 B

two-stage

50 Hz

60 Hz

TRIVAC D 8 B

two-stage

50 Hz

60 Hz

		50 Hz	60 Hz	50 Hz	60 Hz
Nominal pumping speed ¹⁾	m ³ /h (cfm)	4.8 (2.8)	5.8 (3.4)	9.7 (5.7)	11.6 (6.9)
Pumping speed ¹⁾	m ³ /h (cfm)	4.2 (2.5)	5.0 (3.0)	8.5 (5)	10.2 (6)
Ultimate partial pressure without gas ballast ¹⁾	mbar (Torr)	10 ⁻⁴ (0.75 x 10 ⁻⁴)	10 ⁻⁴ (0.75 x 10 ⁻⁴)	10 ⁻⁴ (0.75 x 10 ⁻⁴)	10 ⁻⁴ (0.75 x 10 ⁻⁴)
Ultimate total pressure without gas ballast ¹⁾	mbar (Torr)	< 2 x 10 ⁻³ (< 1.5 x 10 ⁻³)	< 2 x 10 ⁻³ (< 1.5 x 10 ⁻³)	< 2 x 10 ⁻³ (< 1.5 x 10 ⁻³)	< 2 x 10 ⁻³ (< 1.5 x 10 ⁻³)
Ultimate total pressure with gas ballast ¹⁾	mbar (Torr)	< 5 x 10 ⁻³ (< 3.8 x 10 ⁻³)	< 5 x 10 ⁻³ (< 3.8 x 10 ⁻³)	< 5 x 10 ⁻³ (< 3.8 x 10 ⁻³)	< 5 x 10 ⁻³ (< 3.8 x 10 ⁻³)
Water vapor tolerance ¹⁾	mbar (Torr)	30.0 (22.5)	30.0 (22.5)	25.0 (18.8)	25.0 (18.8)
Water vapor capacity	g/h (lbs/h)	95 (0.209)	110 (0.243)	160 (0.353)	190 (0.419)
Oil filling, min. / max.	l (qt)	0.3 / 0.8 (0.3 / 0.85)	0.3 / 0.8 (0.3 / 0.85)	0.3 / 0.9 (0.3 / 0.95)	0.3 / 0.9 (0.3 / 0.95)
Noise level ²⁾ to DIN 45 635, without / with gas ballast	dB(A)	50 / 52	50 / 52	50 / 52	50 / 52
Admissible ambient temperature	°C (°F)	+12 to +40 (+54 to +104)	+12 to +40 (+54 to +104)	+12 to +40 (+54 to +104)	+12 to +40 (+54 to +104)
Motor rating ²⁾	W (HP)	370 (0.50)	370 (0.50)	370 (0.50)	370 (0.50)
Nominal speed	rpm	1500	1800	1500	1800
Type of protection	IP	³⁾	³⁾	³⁾	³⁾
Weight ²⁾	kg (lbs)	17.9 (39.4)	17.9 (39.4)	18.9 (41.6)	18.9 (46.7)
Connections, Intake and Exhaust	DN	16 KF	16 KF	16 KF	16 KF

¹⁾ To DIN 28 400 and following numbers

²⁾ Motor rating and noise levels for the pumps with AC motor 50 Hz.

Any data that deviate from the above for pumps with other motors, and other motor-dependent data are given in chapter "Products", paragraph "Motor Dependent Data for the TRIVAC B, BCS and BCS-PFPE"

³⁾ See paragraph "Motor Dependent Data for the TRIVAC B, BCS and BCS-PFPE"

Ordering Information

TRIVAC D 4 B two-stage

TRIVAC D 8 B two-stage

	Part No.	Part No.
TRIVAC B		
with 1-phase motor 230 V, 50 Hz ¹⁾	112 45	112 55
with dual voltage motor ²⁾ 110-115/210-230 V, 50/60 Hz	140 081 ²⁾	140 082 ²⁾
with 3-phase motor 200-240/380-400 V, 50 Hz / 200-240/380-480 V, 60 Hz ¹⁾	112 46	112 56
230/400 V, 50 Hz, ATEX Category 3 inside and 3 outside inside: II (i) 3G IIC T4 (50 Hz) outside: II (o) 3G IIC T3 (50 Hz)	140 140	140 150
Mains cord for dual voltage motor ²⁾		
230 V Schuko plug	200 81 091	200 81 091
230 V UK plug	200 81 097	200 81 097
230 V CH plug	200 81 099	200 81 099
230 V NEMA plug (200-240 V)	200 81 141	200 81 141
115 V NEMA plug (100-120 V)	200 81 090	200 81 090
Transition connector (250 V AC, 10 A, L+N+PE) only necessary in Switzerland for 1~ pumps	800 001 274	800 001 274
Accessories		
Dust filter		
Filter pot FH 16	140 116 T	140 116 T
Dust filter insert DF 16-25	140 117 S	140 117 S
Adsorption trap		
Filter pot FH 16	140 116 T	140 116 T
Adsorption filter insert RF 16-25	140 118 A	140 118 A
Accessories for dust filter and adsorption trap		
Active charcoal	178 10	178 10
Zeolite	854 20	854 20
Activated aluminium oxide, 1.3 kg (2 l approx.)	854 10	854 10
TK 4-8 cold trap	188 20	188 20
AF 4-8 exhaust filter	189 06	189 06
AR 4-8 exhaust filter with lubricant return	189 20	189 20
AK 4-8 condensate trap	188 06	188 06
OF 4-25 mechanical oil filter	101 91	101 91
CF 4-25 chemical oil filter	101 96	101 96
Connector for gas ballast inlet M 16 x 1.5 – DN 16 KF	168 40V01	168 40V01
Oil drain tap M 16 x 1.5	190 90	190 90
Spare Parts		
Inner body	E 200 10 989	E 200 10 991
Major maintenance kit (without oil)	EK 110 002 622	EK 110 002 620
Minor maintenance kit (without oil)	EK 110 002 628	EK 110 002 627
Shaft sealing replacement kit	EK 110 002 631	EK 110 002 631
Small parts kit	EK 110 002 634	EK 110 002 634
Seal kit	197 20	197 20

For further accessories see section
“Accessories for TRIVAC E, B and BCS”

¹⁾ Certification after 94/9/EG (ATEX), Category 3 inside. Inside: II (i) 3G IIC T4 (50 Hz), T3 (60 Hz)

²⁾ Mains cord 20081091 (Schuko) in delivery included. Other mains cords must be ordered additionally

TRIVAC D 16 B and D 25 B



TRIVAC D 16 B (left) and TRIVAC D 25 B (right)

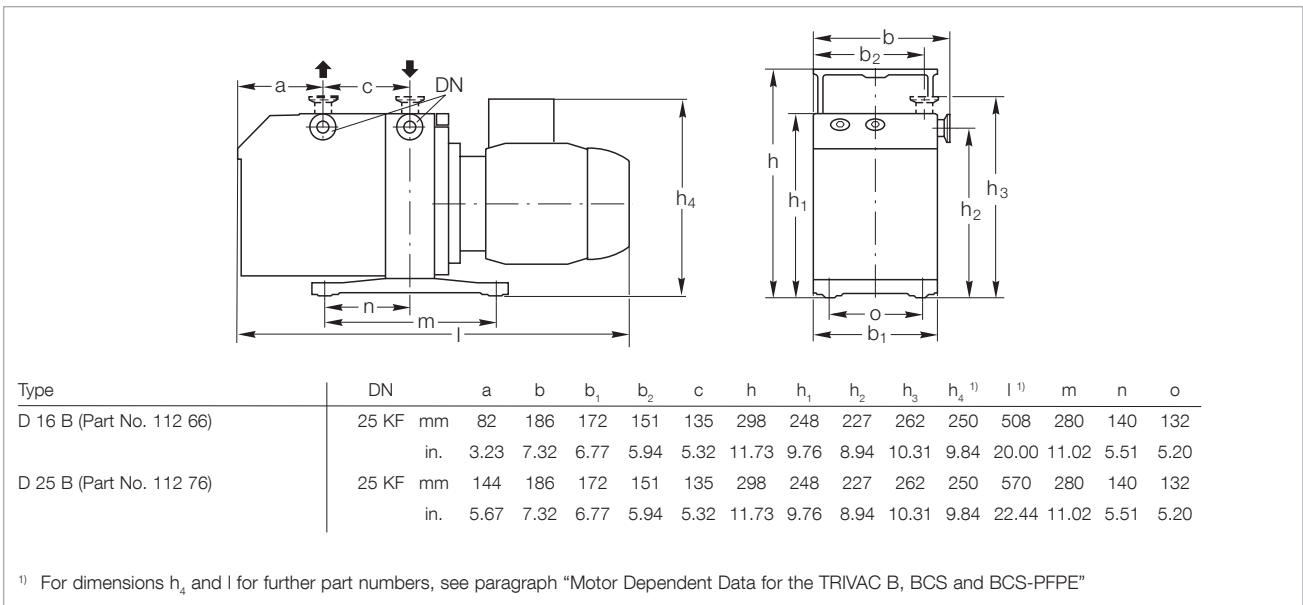

Dimensional drawing for the TRIVAC D 16 and D 25 B

Technical Data

TRIVAC D 16 B
two-stage

TRIVAC D 25 B
two-stage

		50 Hz	60 Hz	50 Hz	60 Hz
Nominal pumping speed ¹⁾	m ³ /h (cfm)	18.9 (11.1)	22.7 (13.4)	29.5 (17.4)	35.4 (20.9)
Pumping speed ¹⁾	m ³ /h (cfm)	16.5 (9.7)	19.8 (11.7)	25.7 (15.1)	30.8 (18.2)
Ultimate partial pressure without gas ballast ¹⁾	mbar (Torr)	10 ⁻⁴ (0.75 x 10 ⁻⁴)	10 ⁻⁴ (0.75 x 10 ⁻⁴)	10 ⁻⁴ (0.75 x 10 ⁻⁴)	10 ⁻⁴ (0.75 x 10 ⁻⁴)
Ultimate total pressure without gas ballast ¹⁾	mbar (Torr)	< 2 x 10 ⁻³ (1.5 x 10 ⁻³)	< 2 x 10 ⁻³ (1.5 x 10 ⁻³)	< 2 x 10 ⁻³ (1.5 x 10 ⁻³)	< 2 x 10 ⁻³ (1.5 x 10 ⁻³)
Ultimate total pressure with gas ballast ¹⁾	mbar (Torr)	< 5 x 10 ⁻³ (3.8 x 10 ⁻³)	< 5 x 10 ⁻³ (3.8 x 10 ⁻³)	< 5 x 10 ⁻³ (3.8 x 10 ⁻³)	< 5 x 10 ⁻³ (3.8 x 10 ⁻³)
Water vapor tolerance ¹⁾	mbar (Torr)	25.0 (18.8)	25.0 (18.8)	25.0 (18.8)	25.0 (18.8)
Water vapor capacity	g/h (lbs/h)	305 (0.672)	370 (0.816)	480 (1.058)	570 (1.257)
Oil filling, min. / max.	l (qt)	0.5 / 1.0 (0.5 / 1.1)	0.5 / 1.0 (0.5 / 1.1)	0.6 / 1.4 (0.6 / 1.5)	0.6 / 1.4 (0.6 / 1.5)
Noise level ²⁾ to DIN 45 635, without / with gas ballast	dB(A)	54 / 56	54 / 56	54 / 56	54 / 56
Admissible ambient temperature	°C (°F)	+12 to +40 (+54 to +104)	+12 to +40 (+54 to +104)	+12 to +40 (+54 to +104)	+12 to +40 (+54 to +104)
Motor rating ²⁾	W (HP)	550 - 750 (0.75 - 1.0)	550 - 750 (0.75 - 1.0)	750 (1)	750 (1)
Nominal speed	rpm	1500	1800	1500	1800
Type of protection	IP	³⁾	³⁾	³⁾	³⁾
Weight ²⁾	kg (lbs)	28 (61.7)	28 (61.7)	32.3 (71.2)	32.3 (71.2)
Connections, Intake and Exhaust	DN	25 KF	25 KF	25 KF	25 KF

¹⁾ To DIN 28 400 and following numbers

²⁾ Motor rating and noise levels for the pumps with 3-phase motor 50 Hz.

Any data that deviate from the above for pumps with other motors, and other motor-dependent data are given in chapter "Products", paragraph "Motor Dependent Data for the TRIVAC B, BCS and BCS-PFPE"

³⁾ See paragraph "Motor Dependent Data for the TRIVAC B, BCS and BCS-PFPE"

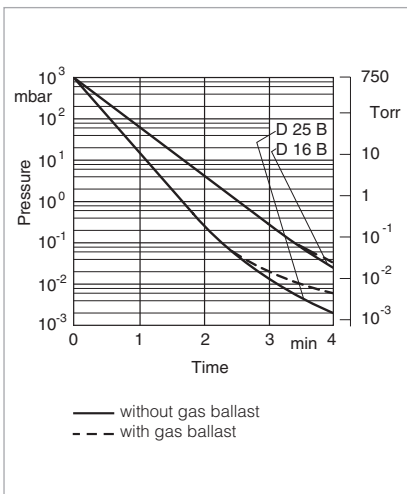

Pump-down characteristics of a 100 l vessel at 50 Hz

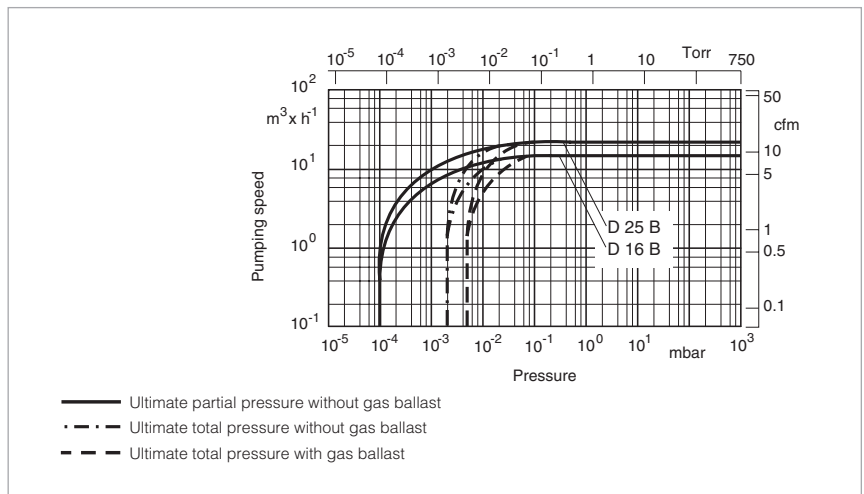

Pumping speed characteristics at 50 Hz (60 Hz curves at the end of the chapter)

Ordering Information

TRIVAC D 16 B two-stage

TRIVAC D 25 B two-stage

	Part No.	Part No.
TRIVAC B		
with 1-phase motor		
230 V, 50 Hz ¹⁾	112 65	112 75
218 - 242 V, 50/60 Hz ¹⁾	113 25 ²⁾	113 35 ²⁾
110/220 V, 50 Hz / 115/208-230 V, 60 Hz ³⁾	898 698	-
with 3-phase motor		
200-346 V (200 V IE3) /	112 66	112 76
380-400 V (380-400 V IE3), 50 Hz /	113 33 (LVO 210)	
200-240 (208-240 V IE3) /		
380-480 V (416-480 V IE3), 60 Hz ¹⁾		
200-240 V (IE3, Japan), 50 Hz /	112 66J (LVO 100)	112 76J (LVO 100)
200-380 V (IE3, Japan), 60 Hz	113 33J (LVO 210)	-
230/400 V, 50 Hz,		
ATEX Category 3 inside and 3 outside		
inside: II (j) 3G IIC T4 (50 Hz)	140 160	140 170
outside: II (o) 3G IIC T3 (50 Hz)		
Accessories		
Mains cord for Part No. 898 698		
115 V	E 721 27 874	-
230 V	E 721 27 875	-
Dust filter		
Filter pot FH 16	140 125 T	140 125 T
Dust filter insert DF 16-25	140 117 S	140 117 S
Adsorption trap		
Filter pot FH 25	140 125 T	140 125 T
Adsorption filter insert RF 16-25	140 118 A	140 118 A
Accessories for dust filter and adsorption trap		
Active charcoal	178 10	178 10
Zeolite	854 20	854 20
Activated aluminium oxide,	854 10	854 10
1.3 kg (2 l approx.)		
AF 16-25 exhaust filter	189 11	189 11
AR 16-25 exhaust filter with lubricant return	189 21	189 21
AK 16-25 condensate trap	188 11	188 11
OF 4-25 mechanical oil filter	101 91	101 91
CF 4-25 chemical oil filter	101 96	101 96
Connector for gas ballast inlet		
M 16 x 1.5 – DN 16 KF	168 40V01	168 40V01
Oil drain tap M 16 x 1.5	190 90	190 90
Spare Parts		
Inner body	E 200 10 956	E 200 10 960
Major maintenance kit (without oil)	EK 110 002 618	EK 110 002 616
Minor maintenance kit (without oil)	EK 110 002 626	EK 110 002 625
Shaft sealing ring replacement kit	EK 110 002 630	EK 110 002 630
Small parts kit	EK 110 002 635	EK 110 002 635
Seal kit	197 21	197 21

For further accessories see section "Accessories for TRIVAC E, B and BCS"

¹⁾ Certification after 94/9/EG (ATEX), Category 3 inside. Inside: II (j) 3G IIC T4 (50 Hz), T3 (60 Hz)

²⁾ With cable EURO Schuko. Other cables for wide range motor upon request

³⁾ Mains cord for dual voltage motor see paragraph "Motor Dependent Data for the TRIVAC B, BCS and BCS-PFPE"; TRIVAC D 16 B / D 25 B

Only available for purchase in North and South America

Ordering Information

TRIVAC D 16 B two-stage

TRIVAC D 25 B two-stage

	Part No.	Part No.
TRIVAC B		
with 1-phase motor		
110 V, 50 Hz, NEMA plug /		
115 V, 60 Hz, NEMA plug	912 65-1	-
208-230 V, 60/50 Hz, NEMA plug	912 65-2	-
208-230 V, 60/50 Hz, NEMA plug	-	912 75-2

TRIVAC D 40 B and D 65 B

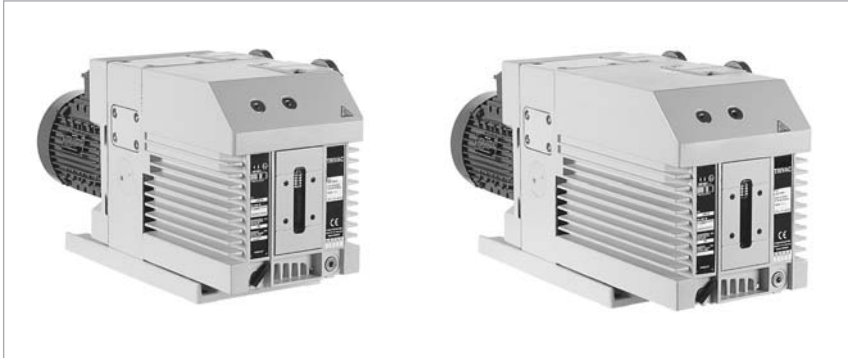

TRIVAC D 40 B (left) and TRIVAC D 65 B (right)

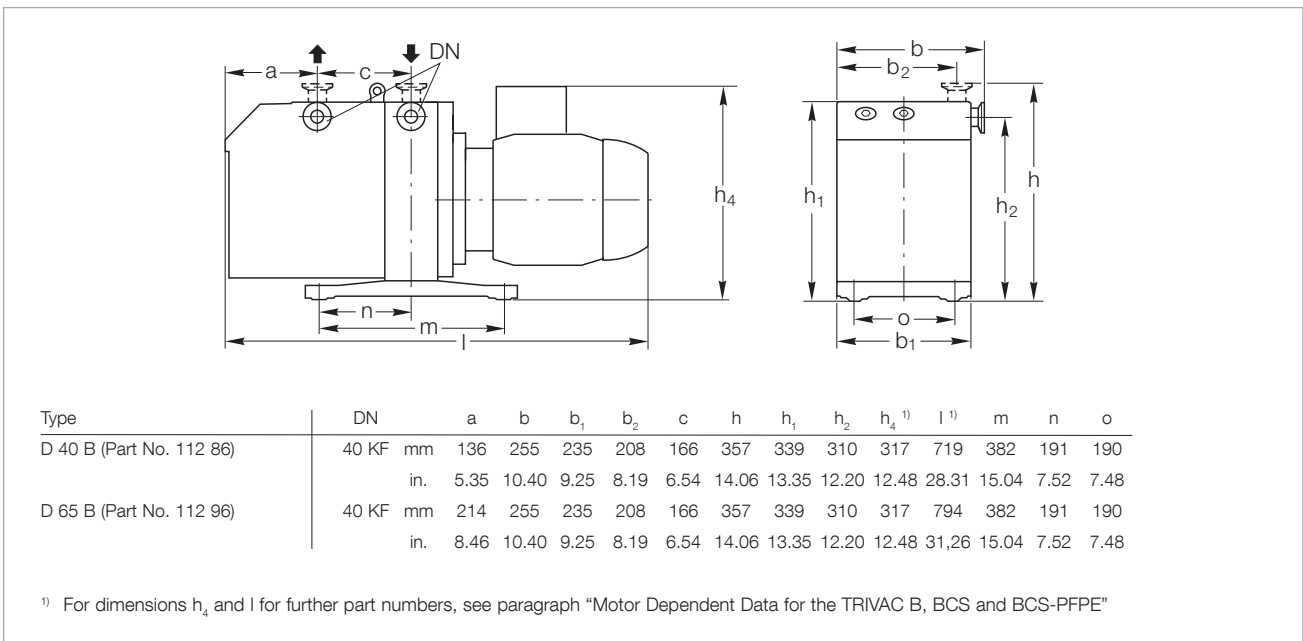

Dimensional drawing for the TRIVAC D 40 and D 65 B

Technical Data

TRIVAC D 40 B

TRIVAC D 65 B

two-stage

two-stage

50 Hz

60 Hz

50 Hz

60 Hz

		50 Hz	60 Hz	50 Hz	60 Hz
Nominal pumping speed ¹⁾	m ³ /h (cfm)	46 (27)	55 (32.5)	75 (44)	90 (53)
Pumping speed ¹⁾	m ³ /h (cfm)	40 (24)	48 (28)	65 (38)	78 (46)
Ultimate partial pressure without gas ballast ¹⁾	mbar (Torr)	10 ⁻⁴ (0.75 x 10 ⁻⁴)	10 ⁻⁴ (0.75 x 10 ⁻⁴)	10 ⁻⁴ (0.75 x 10 ⁻⁴)	10 ⁻⁴ (0.75 x 10 ⁻⁴)
Ultimate total pressure without gas ballast ¹⁾	mbar (Torr)	< 2 x 10 ⁻³ (< 1.5 x 10 ⁻³)	< 2 x 10 ⁻³ (< 1.5 x 10 ⁻³)	< 2 x 10 ⁻³ (< 1.5 x 10 ⁻³)	< 2 x 10 ⁻³ (< 1.5 x 10 ⁻³)
Ultimate total pressure with gas ballast ¹⁾	mbar (Torr)	< 5 x 10 ⁻³ (< 3.8 x 10 ⁻³)	< 5 x 10 ⁻³ (< 3.8 x 10 ⁻³)	< 5 x 10 ⁻³ (< 3.8 x 10 ⁻³)	< 5 x 10 ⁻³ (< 3.8 x 10 ⁻³)
Water vapor tolerance ¹⁾	mbar (Torr)	40 (30)	40 (30)	40 (30)	40 (30)
Water vapor capacity	g/h (lbs/h)	1185 (2.612)	1420 (3.131)	1925 (4.244)	2310 (5.093)
Oil filling, min. / max.	l (qt)	1.7 / 2.6 (1.8 / 2.7)	1.7 / 2.6 (1.8 / 2.7)	2.0 / 3.3 (2.1 / 3.5)	2.0 / 3.3 (2.1 / 3.5)
Noise level ²⁾ to DIN 45 635, without / with gas ballast	dB(A)	57 / 59	57 / 59	57 / 59	57 / 59
Admissible ambient temperature	°C (°F)	+12 to +40 (+54 to +104)	+12 to +40 (+54 to +104)	+12 to +40 (+54 to +104)	+12 to +40 (+54 to +104)
Motor rating 50/60 Hz ²⁾	W (HP)	2200 (3.0)	2200 (3.0)	2200 (3.0)	2200 (3.0)
Nominal speed ²⁾	rpm	1420	1710	1420	1710
Type of protection	IP	3)	3)	3)	3)
Weight ²⁾	kg (lbs)	75.3 (166)	75.3 (166)	84.5 (186.3)	84.5 (186.3)
Connections, Intake and Exhaust	DN	40 KF	40 KF	40 KF	40 KF

¹⁾ To DIN 28 400 and following numbers

²⁾ Motor rating and noise levels for the pumps with 3-phase motor 50 Hz.

Any data that deviate from the above for pumps with other motors, and other motor-dependent data are given in chapter "Products", paragraph "Motor Dependent Data for the TRIVAC B, BCS and BCS-PFPE"

³⁾ See paragraph "Motor Dependent Data for the TRIVAC B, BCS and BCS-PFPE"

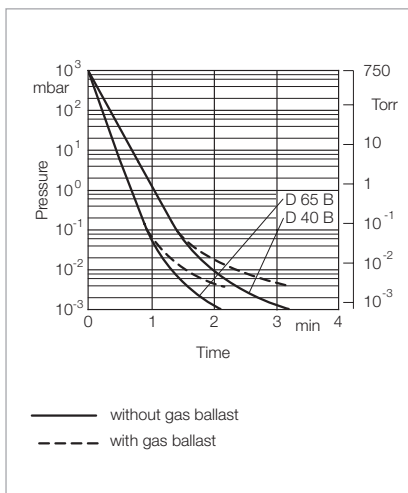

Pump-down characteristics of a 100 l vessel at 50 Hz

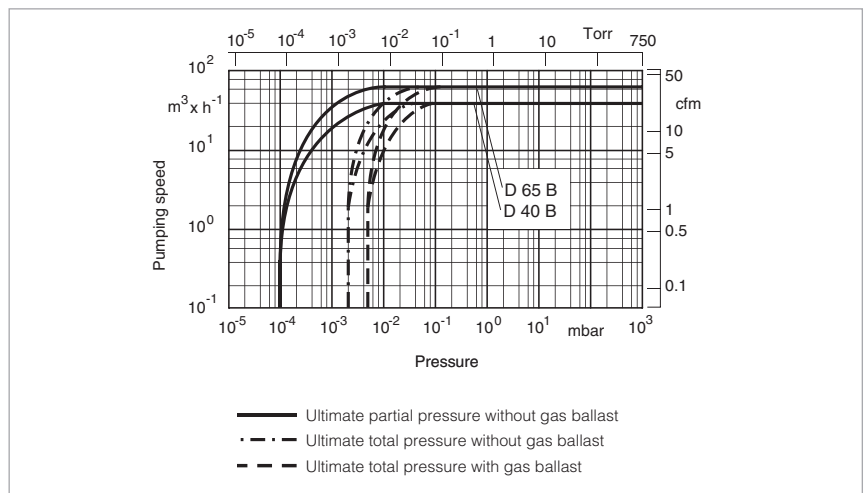

Pumping speed characteristics at 50 Hz (60 Hz curves at the end of the chapter)

Ordering Information

TRIVAC D 40 B two-stage

TRIVAC D 65 B two-stage

	Part No.	Part No.
TRIVAC B with 3-phase motor 200-240 V (200 V IE3) / 380-400 V (380-400 V IE3), 50 Hz / 200-240 V (208-240 V IE3) / 380-480 V (416-480 V IE3), 60 Hz ¹⁾	112 86	112 96
200-346 V (IE3 Japan), 50 Hz 220-380 V (IE3 Japan), 60 Hz	112 86J	112 96J
219-242/380-420 V, 50 Hz ATEX Category 3 inside and 3 outside inside: II (i) 3G IIC T4 (50 Hz) outside: II (o) 3G IIC T3 (50 Hz)	140 180	140 190
Accessories		
Roots pump adaptor	168 30	168 30
AS 30-60 dust separator	186 16	186 16
MF 30-60 molecular filter	186 17	186 17
Dust filter Filter pot FH 40-65 Dust filter insert DF 40-65	140 140 T 140 141 S	140 140 T 140 141 S
Adsorption trap Filter pot FH 40-65 Adsorption filter insert RF 40-65	140 140 T 140 142 A	140 140 T 140 142 A
Accessories for dust filter and adsorption trap Active charcoal Zeolite Activated aluminium oxide, 1.3 kg (2 l approx.)	178 10 854 20 854 10	178 10 854 20 854 10
AF 40-65 exhaust filter	189 16	189 16
AR 40-65 exhaust filter with lubricant return	189 22	189 22
AK 40-65 condensate trap	188 16	188 16
OF 40-65 mechanical oil filter	101 92	101 92
CF 40-65 chemical oil filter	101 97	101 97
Connector for gas ballast inlet M 16 x 1.5 – DN 16 KF	168 40V01	168 40V01
Oil drain tap M 16 x 1.5	190 90	190 90
Spare Parts		
Inner body	E 200 10 933	E 200 10 944
Major maintenance kit (without oil)	EK 110 002 613	EK 110 002 612
Minor maintenance kit (without oil)	EK 110 002 624	EK 110 002 624
Shaft sealing ring replacement kit	EK 110 002 629	EK 110 002 629
Small parts kit	EK 110 002 636	EK 110 002 636
Seal kit	197 22	197 22

For further accessories see section “Accessories for TRIVAC E, B and BCS”

¹⁾ Certification after 94/9/EG (ATEX), Category 3 inside. Inside: II (i) 3G IIC T4 (50 Hz), T3 (60 Hz)

TRIVAC D 16 B-DOT to D 40 B-DOT

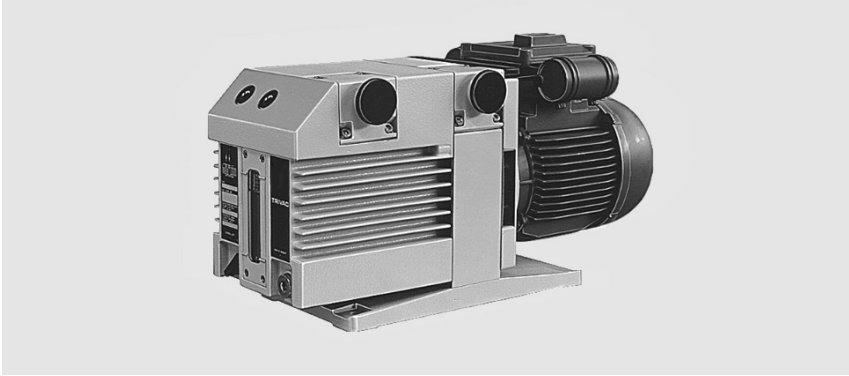

TRIVAC D 16 B-DOT

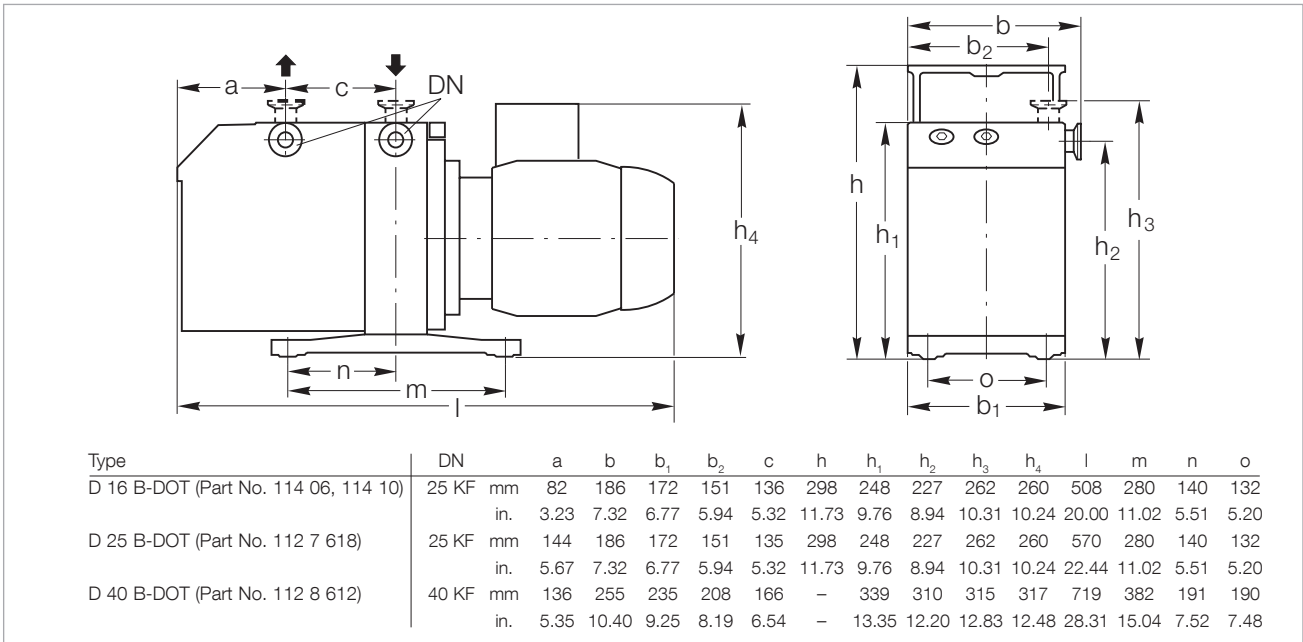

Dimensional drawing for the TRIVAC D B-DOT pumps

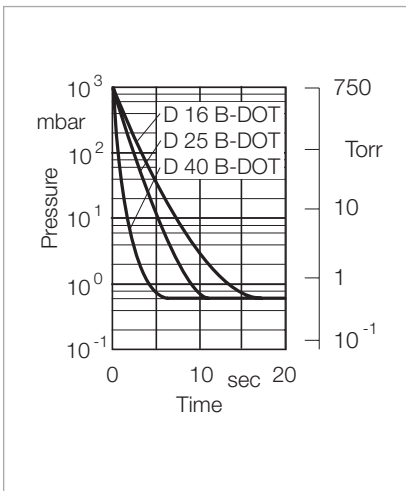

Pump-down characteristics of a 10 l vessel at 50 Hz

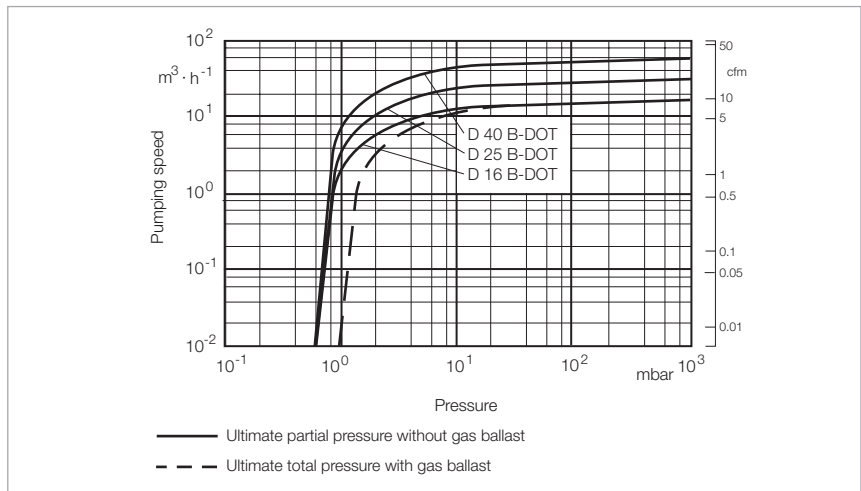

Pumping speed characteristics at 50 Hz (60 Hz curves at the end of the chapter)

Technical Data

TRIVAC D 16 B-DOT two-stage

		50 Hz	60 Hz
Nominal pumping speed ¹⁾	m ³ /h (cfm)	18.9 (11.1)	22.7 (13.4)
Pumping speed ¹⁾	m ³ /h (cfm)	16.5 (9.7)	19.8 (11.7)
Ultimate total pressure without gas ballast ¹⁾	mbar (Torr)	< 6 x 10 ⁻¹ (< 4.5 x 10 ⁻¹)	< 6 x 10 ⁻¹ (< 4.5 x 10 ⁻¹)
Ultimate total pressure with gas ballast ¹⁾	mbar (Torr)	< 9 x 10 ⁻¹ (< 6.75 x 10 ⁻¹)	< 9 x 10 ⁻¹ (< 6.75 x 10 ⁻¹)
Water vapor tolerance ¹⁾	mbar (Torr)	25 (18.75)	25 (18.75)
Water vapor capacity	g/h (lbs/h)	305 (0.672)	370 (0.815)
Brake fluid filling, min. / max.	l (qt)	0.45 / 1.0 (0.5 / 1.1)	0.45 / 1.0 (0.5 / 1.1)
Noise level to DIN 45 635, without / with gas ballast	dB(A)	54 / 56	54 / 56
Admissible ambient temperature	°C (°F)	+12 to +40 (+54 to +104)	+12 to +40 (+54 to +104)
Motor rating	W (HP)	550 (0.75)	550 (0.75)
Nominal speed	rpm	1500	1800
Type of protection	IP	2)	2)
Weight	kg (lbs)	28.2 (62.2)	28.2 (62.2)
Connections, Intake and Exhaust	DN	25 KF	25 KF

¹⁾ To DIN 28 400 and following numbers

²⁾ See paragraph "Motor Dependent Data for the TRIVAC B, BCS and BCS-PFPE"

Ordering Information

TRIVAC D 16 B-DOT two-stage

	Part No.
TRIVAC B-DOT with 3-phase motor 200-240 V (200 V IE3) / 380-400 V (380-400 V IE3), 50 Hz / 200-240 (208-240 V IE3) / 380-480 V (416-480 V IE3), 60 Hz	114 06 114 10 (with limit switch system LSS 16-25)
AF 16-25 DOT exhaust filter	124 16
AK DOT condensate trap	110 78
Seal kit DOT	200 39 059

Technical Data

TRIVAC D 25 B-DOT two-stage

		50 Hz	60 Hz
Nominal pumping speed ¹⁾	m ³ /h (cfm)	29.5 (17.4)	35.4 (20.9)
Pumping speed ¹⁾	m ³ /h (cfm)	25.7 (17.4)	30.8 (18.2)
Ultimate total pressure without gas ballast ¹⁾	mbar (Torr)	< 6 x 10 ⁻¹ (< 4.5 x 10 ⁻¹)	< 6 x 10 ⁻¹ (< 4.5 x 10 ⁻¹)
Ultimate total pressure with gas ballast ¹⁾	mbar (Torr)	< 9 x 10 ⁻¹ (< 6.75 x 10 ⁻¹)	< 9 x 10 ⁻¹ (< 6.75 x 10 ⁻¹)
Water vapor tolerance ¹⁾	mbar (Torr)	25 (18.75)	25 (18.75)
Water vapor capacity	g/h (lbs/h)	480 (1.058)	570 (1.257)
Brake fluid filling, min. / max.	l (qt)	0.6 / 1.4 (6.3 / 1.5)	0.6 / 1.4 (6.3 / 1.5)
Noise level to DIN 45 635, without / with gas ballast	dB(A)	54 / 56	54 / 56
Admissible ambient temperature	°C (°F)	+12 to +40 (+54 to +104)	+12 to +40 (+54 to +104)
Motor rating	W (HP)	550 (0.75)	550 (0.75)
Nominal speed	rpm	1500	1800
Type of protection	IP	²⁾	²⁾
Weight	kg (lbs)	32.5 (71.7)	32.5 (71.7)
Connections, Intake and Exhaust	DN	25 KF	25 KF

¹⁾ To DIN 28 400 and following numbers

²⁾ See paragraph "Motor Dependent Data for the TRIVAC B, BCS and BCS-PFPE"

Ordering Information

TRIVAC D 25 B-DOT two-stage

	Part No.
TRIVAC B-DOT with 3-phase motor 200-240 V (200 V IE3) / 380-400 V (380-400 V IE3), 50 Hz / 200-240 (208-240 V IE3) / 380-480 V (416-480 IE3), 60 Hz	112 76 18
200-346 V (IE3 Japan), 50 Hz / 200-380 V (IE3 Japan), 60 Hz	112 76 18J
AF 16-25 DOT exhaust filter	124 16
AK DOT condensate trap	110 78
Seal kit DOT	200 39 059

Technical Data

TRIVAC D 40 B-DOT two-stage

		50 Hz	60 Hz
Nominal pumping speed ¹⁾	m ³ /h (cfm)	46.0 (27.0)	55.0 (32.5)
Pumping speed ¹⁾	m ³ /h (cfm)	40.0 (24.0)	48.0 (28.0)
Ultimate total pressure without gas ballast ¹⁾	mbar (Torr)	< 6 x 10 ⁻¹ (< 4.5 x 10 ⁻¹)	< 6 x 10 ⁻¹ (< 4.5 x 10 ⁻¹)
Ultimate total pressure with gas ballast ¹⁾	mbar (Torr)	< 9 x 10 ⁻¹ (< 6.75 x 10 ⁻¹)	< 9 x 10 ⁻¹ (< 6.75 x 10 ⁻¹)
Water vapor tolerance ¹⁾	mbar (Torr)	40 (30)	40 (30)
Water vapor capacity	g/h (lbs/h)	1185 (2.612)	1420 (3.130)
Brake fluid filling, min. / max.	l (qt)	1.7 / 2.6 (1.8 / 2.7)	1.7 / 2.6 (1.8 / 2.7)
Noise level to DIN 45 635, without / with gas ballast	dB(A)	57 / 59	57 / 59
Admissible ambient temperature	°C (°F)	+12 to +40 (+54 to +104)	+12 to +40 (+54 to +104)
Motor rating	W (HP)	2200 (3.0)	2200 (3.0)
Nominal speed	rpm	1500	1800
Type of protection	IP	²⁾	²⁾
Weight	kg (lbs)	75.8 (167)	75.8 (167)
Connections, Intake and Exhaust	DN	40 KF	40 KF

¹⁾ To DIN 28 400 and following numbers

²⁾ See paragraph "Motor Dependent Data for the TRIVAC B, BCS and BCS-PFPE"

Ordering Information

TRIVAC D 40 B-DOT two-stage

	Part No.
TRIVAC B-DOT with 3-phase motor 200-240 V (200 V IE3) / 380-400 V (380-400 V IE3), 50 Hz / 200-240 (208-240 V IE3) / 380-480 V (416-480 V IE3), 60 Hz	112 86 12
AF 40-65 DOT exhaust filter	101 15
AK DOT condensate trap	upon request
Seal kit DOT	200 39 707

TRIVAC D 65 B ³He

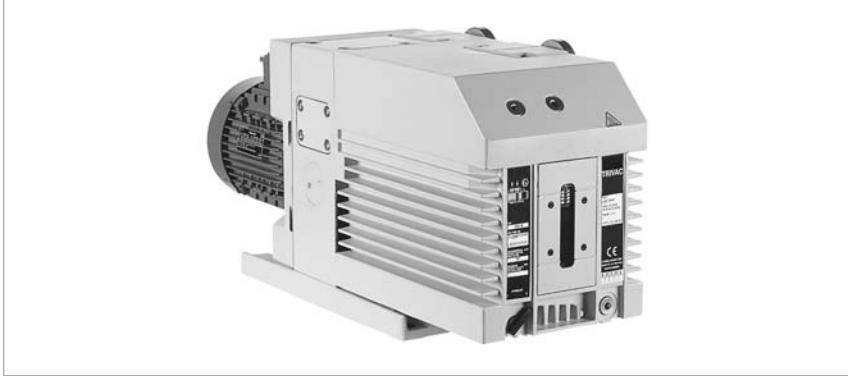

TRIVAC D 65 B ³He

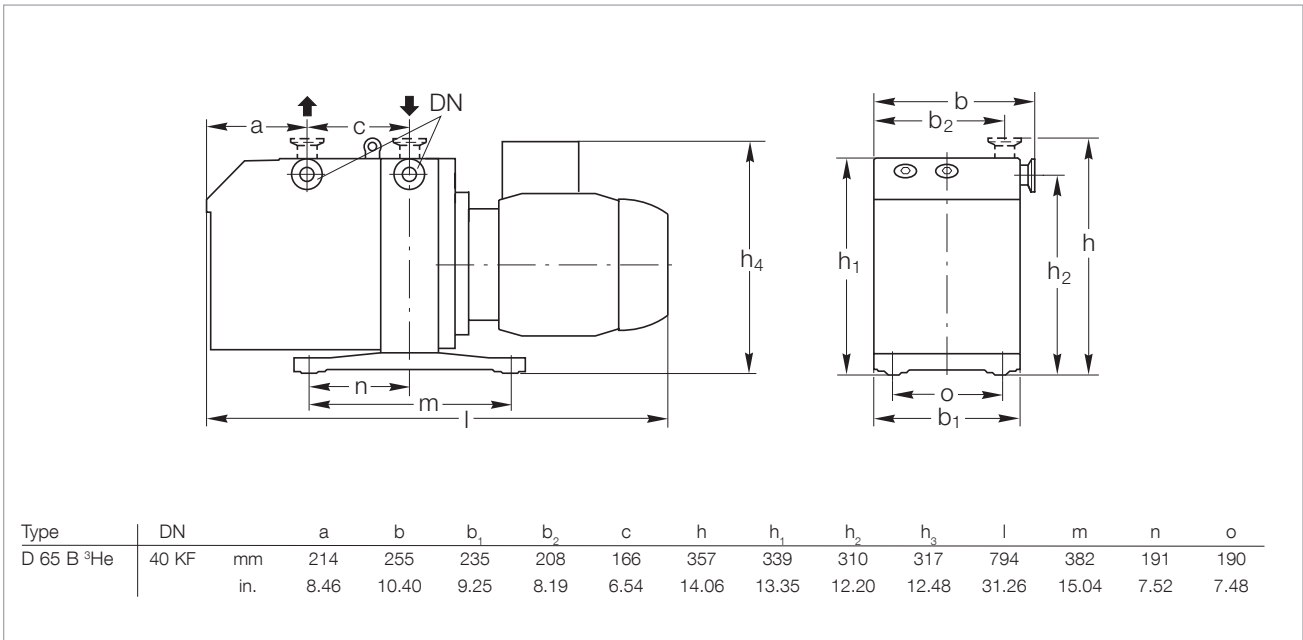

Dimensional drawing for the TRIVAC D 65 B ³He

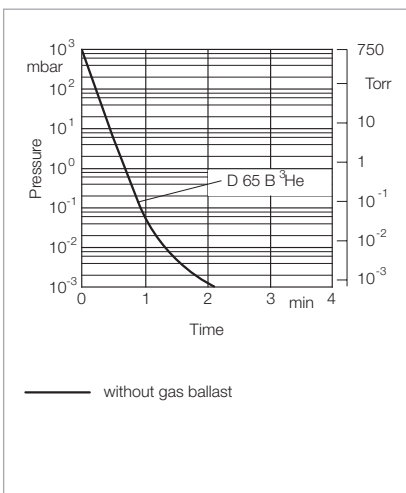

Pump-down characteristics of a 100 l vessel at 50 Hz

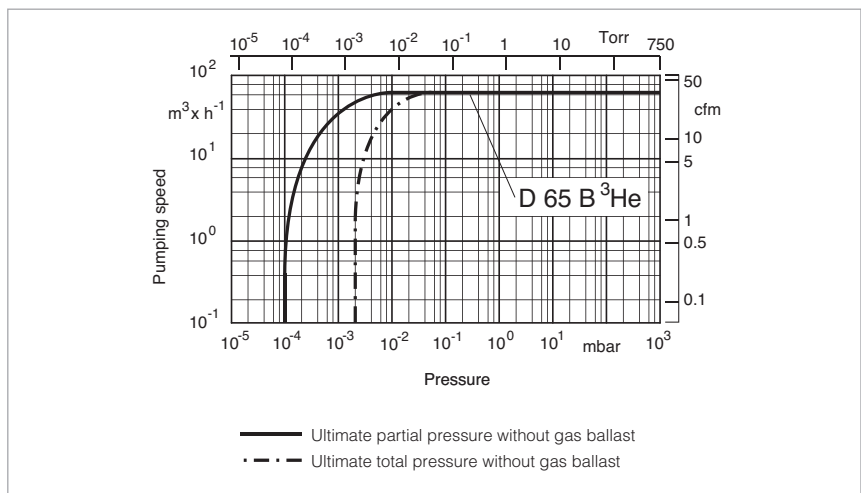

Pumping speed characteristics at 50 Hz (60 Hz curves at the end of the chapter)

Technical Data

TRIVAC D 65 B ³He

		50 Hz	60 Hz
Nominal pumping speed ¹⁾	m ³ /h (cfm)	75 (44)	90 (53)
Pumping speed ¹⁾	m ³ /h (cfm)	65 (38)	78 (46)
Ultimate partial pressure without gas ballast ¹⁾	mbar (Torr)	10 ⁻⁴ (0.75 x 10 ⁻⁴)	10 ⁻⁴ (0.75 x 10 ⁻⁴)
Ultimate total pressure without gas ballast ¹⁾	mbar (Torr)	< 2.0 x 10 ⁻³ (< 1.5 x 10 ⁻³)	< 2.0 x 10 ⁻³ (< 1.5 x 10 ⁻³)
Oil filling with LEYBONOL LVO 100, min. / max.	l (qt)	2.0 / 3.3 (2.1 / 3.5)	2.0 / 3.3 (2.1 / 3.5)
Leak rate	mbar x l x sec ⁻¹	< 1.0 x 10 ⁻⁷	< 1.0 x 10 ⁻⁷
Noise level to DIN 45 635, without / with gas ballast	dB(A)	57 / 59	57 / 59
Admissible ambient temperature	°C (°F)	+12 to +40 (+54 to +104)	+12 to +40 (+54 to +104)
Motor rating ²⁾	W (HP)	2200 (3)	2200 (3)
Nominal speed ²⁾	rpm	1500	1800
Type of protection	IP	³⁾	³⁾
Weight	kg (lbs)	84.5 (186.3)	84.5 (186.3)
Connections, Intake and Exhaust	DN	40 KF	40 KF

Ordering Information

TRIVAC D 65 B ³He

	Part No.
TRIVAC B ³ He with 3-phase motor 200-240 V (200 V IE3) / 380-400 V (380-400 V IE3), 50 Hz / 200-240 (208-240 V IE3) / 380-480 V (416-480 V IE3), 60 Hz	112 96 46

¹⁾ To DIN 28 400 and following numbers

²⁾ Motor rating and noise levels for the pumps with AC motor 50 Hz.

Any data that deviate from the above for pumps with other motors, and other motor-dependent data are given in chapter "Products", paragraph "Motor Dependent Data for the TRIVAC B, BCS and BCS-PFPE"

³⁾ See paragraph "Motor Dependent Data for the TRIVAC B, BCS and BCS-PFPE"

TRIVAC D 16 B-Ex (Explosion Protected and Pressure Burst Resistant)

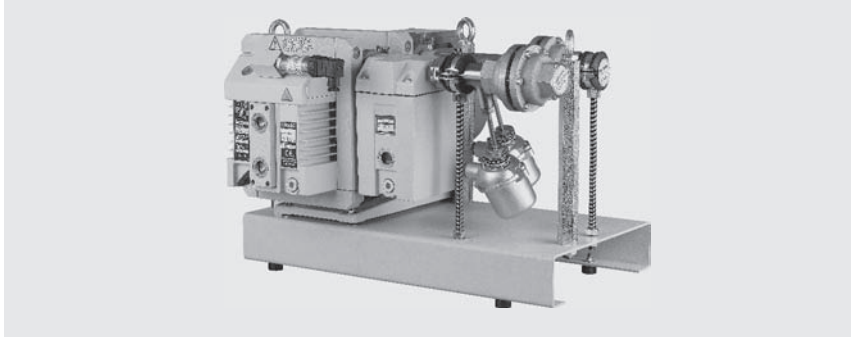

ATEX
Category 1 inside and 2 outside

TRIVAC D 16 B-Ex

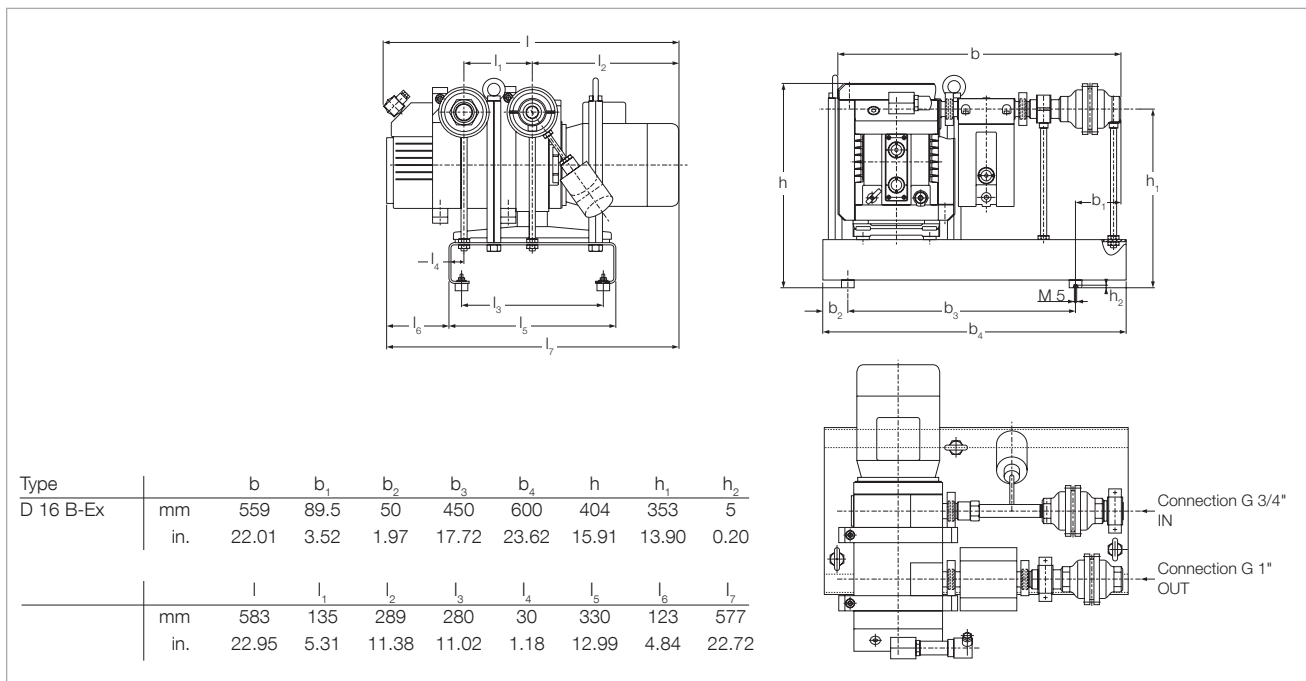

Dimensional drawing for the TRIVAC D 16 B-Ex (explosion protected and pressure burst resistant)

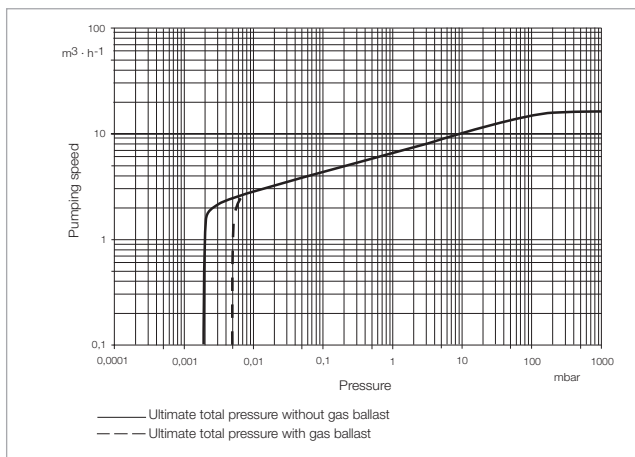

Pumping speed characteristics of TRIVAC D 16 B-Ex [IIB3 T4]
 (Part No. 140 091)

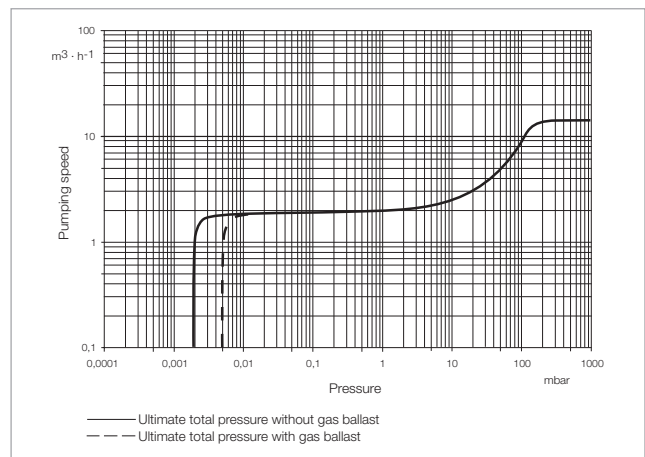

Pumping speed characteristics of TRIVAC D 16 B-Ex [IIC T4]
 (Part No. 140 092)

Technical Data

TRIVAC D 16 B-Ex



(Explosion Protected and Pressure Burst Resistant) Two-Stage

Nominal pumping speed ¹⁾	m ³ /h (cfm)	18.9 (11.1)
Pumping speed (for Part No. 140 091 / 140 092) ¹⁾	m ³ /h (cfm)	16 / 15 (9.4/8.8)
Ultimate partial pressure without gas ballast ¹⁾	mbar (Torr)	1 x 10 ⁻⁴ (< 0.75 x 10 ⁻³)
Ultimate total pressure with gas ballast ¹⁾	mbar (Torr)	< 5 x 10 ⁻³ (< 3.8 x 10 ⁻³)
Water vapor tolerance ¹⁾	mbar (Torr)	25 (18.75)
Water vapor capacity	g/h (lbs/h)	305 (0.672)
Oil filling, min. / max.	l (qt)	0.55 / 1.3 (0.58 / 1.4)
Motor		3~, 230 V / 400 V, 50 Hz, Ex e II T4
Type of protection	IP	54
Maximum gas inlet temperature	°C (°F)	60 (140)
Highest permissible pressure in the oil box	mbar (Torr)	1500 (1125)
Ambient temperature (t _a)	°C (°F)	+12 to +40 (+46 to +104)
Maximum surface temperature	°C (°F)	135 (275)
Max. Inlet pressure	mbar (Torr)	Atmospheric pressure
Weight (complete system)	kg (lbs)	72 (159)
Materials (materials in contact with the gas)		Steel, hardened steel, spring steel, stainless steel, zinc, aluminium and aluminium alloys, grey cast iron 25, FKM, felt, glass, silicone, polyamide
Connections		
Intake side	Inside thread	G 3/4"
Pressure side	Inside thread	G 1"

Ordering Information

TRIVAC D 16 B-Ex

(Explosion Protected and Pressure Burst Resistant) Two-Stage

	Part No.
TRIVAC D 16 B-Ex IIB3 T4 in accordance with 94/9/EC [ II inside: 1G IIB3 T4 outside: 2G IIB T4 (12 °C < t _a < 40 °C) X EC Type Examination Certificate: IBExU03ATEX1017 X]	140 091
TRIVAC D 16 B-Ex IIC T4 ²⁾ in accordance with 94/9/EC [ II inside: 1G IIC (no C ₂ H ₂ , CS ₂) T4 outside: 2G IIC T4 (12 °C < t _a < 40 °C) X EC Type Examination Certificate: IBExU03ATEX1016 X]	140 092 ²⁾

¹⁾ To DIN 28 400 and following numbers

²⁾ with the exception of acetylene and carbon bisulphide

For all enquiries and orders relating to category 1 and 2 ATEX products please exclusively use our ATEX questionnaire. You can find this questionnaire at the end of the full-line catalog together with the fax forms or on the Internet under "www.leybold.com" under Download Documents in the area Documentation.

TRIVAC BCS, Two-Stage Rotary Vane Vacuum Pumps

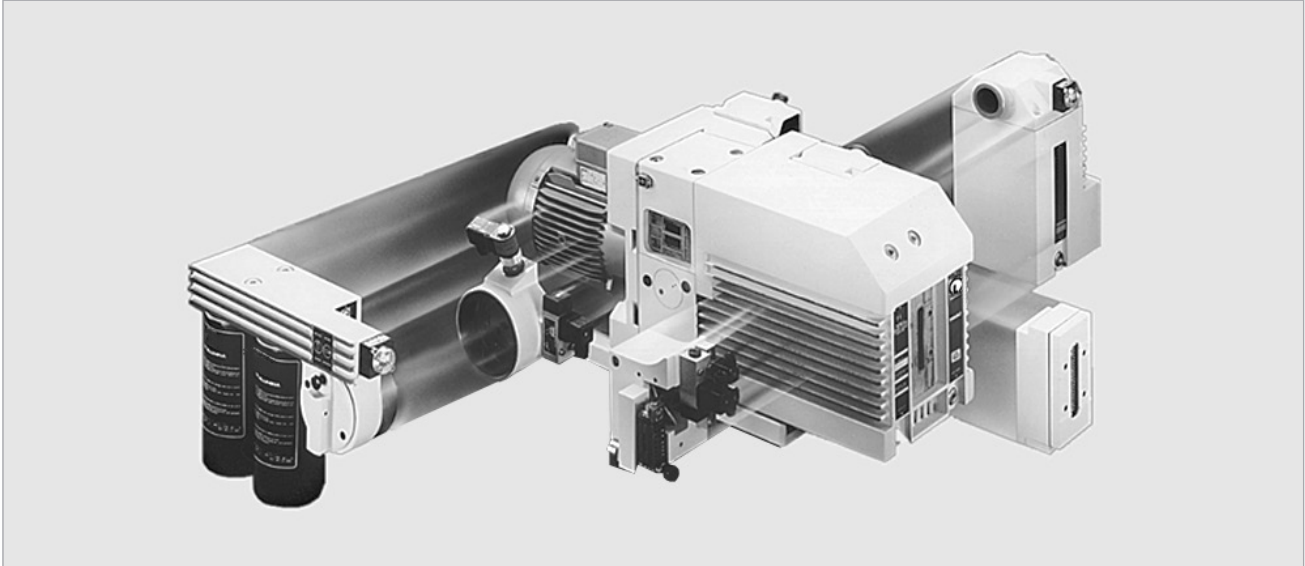

TRIVAC System

The TRIVAC BCS pumps are oil sealed vacuum pumps operating according to the rotary vane principle. Oil which is injected into the pump chamber is used for sealing, lubrication and cooling purposes.

The pump body is assembled from individual parts without sealing components. The parts are pinned in order to ensure easy disassembly and reassembly of the parts.

The motor is connected to the pumping section via an elastic coupling.

In addition, the TRIVAC BCS is ready for system integration (adaptable to different applications).

Advantages to the User

- Compact design
- Low noise operation with hardly any vibrations
- Built-in oil pump
- Continuous operation even at 1000 mbar (750 Torr)
- Pressure-lubricated sliding bearings

- Anti-suckback valve controlled via the oil pressure, no backstreaming of oil, independent of the operating mode, with or without gas ballast
- Low backstreaming of oil within the pump
- High pumping speed down to ultimate pressure
- Either vertical or horizontal intake and exhaust ports
- All controls as well as the oil sight glass are located on the face side
- Low power consumption
- Produces very little heat
- Exchangeable inner section
- Main flow oil filters may be fitted
- Very long service life
- Modular system
- Service-friendly
- Built-in temperature switch for temperature monitoring
- Corrosion protected – the use of yellow metals has been avoided; only grey cast iron, surface treated aluminium, steel and stainless steel is used
- Double shaft seal

Typical Applications

- In all areas of vacuum engineering
- Pumping of corrosive or aggressive media
- Production of semiconductors and in the area of chemistry
- Research and production
- Generation of rough and medium vacuum
- Backing pump in pump sets, i.e. in connection with Roots, diffusion, turbo or cryopumps

Supplied Equipment

- Small flanges
- Centering, sealing and clamping rings
- The intake port includes a dirt trap

BCS pumps are supplied with a filling of standard oil LEYBONOL LVO 100.

All pumps are subjected to a vacuum test before delivery!

TRIVAC SYSTEM

The TRIVAC BCS and its accessories

- CFS, chemical filter with safety isolation valve
- ARS, exhaust filter with lubricant return
- IGS, inert gas system
- LSS, limit switch system

make up the TRIVAC SYSTEM.

TRIVAC BCS-PFPE

In many applications the use of synthetic lubricants like perfluoropolyether (PFPE) offers superior characteristics compared to mineral oils.

Advantages of perfluoropolyether (PFPE) LEYBONOL LVO 400:

- Practically inert against all chemical and oxidizing influences
- No polymerization under the influence of high energy radiation
- In part significantly increased oil change intervals
- Thermally highly stable. Thermal decomposition will only occur at temperatures over 290 °C (554 °F)

BCS-PFPE pumps have been especially prepared for operation with LEYBONOL LVO 400 and are supplied **without** the oil filling.

We recommend using our operating fluid LEYBONOL LVO 400 and always to install a chemical oil filter CF or CFS.

TRIVAC D 16 BCS to D 65 BCS

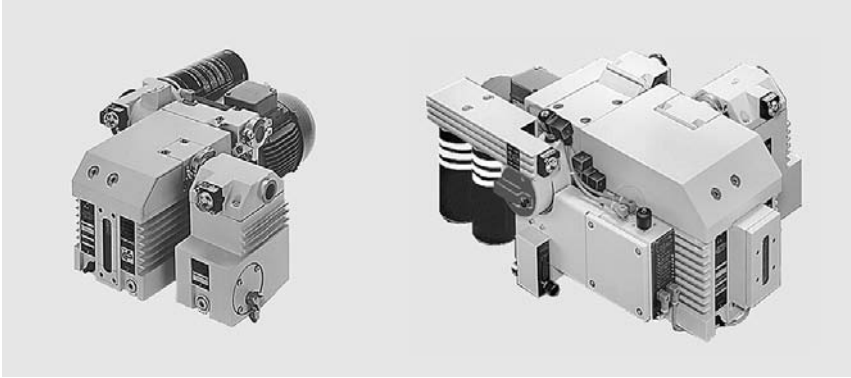

TRIVAC D 25 BCS with ARS and CFS (left)
and TRIVAC D 65 BCS with CFS, ARS, IGS, LSS, EIS – TRIVAC SYSTEM (right)

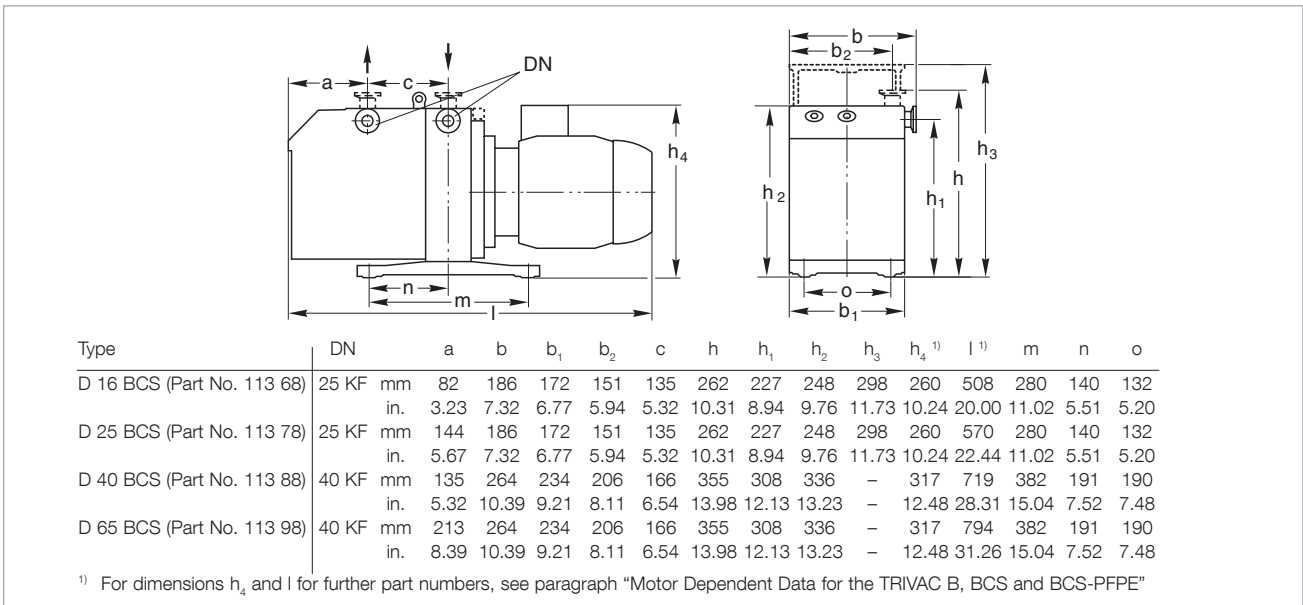

Dimensional drawing for the TRIVAC D 16 to D 65 BCS

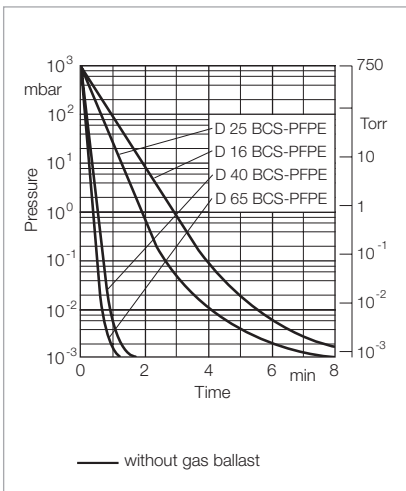

Pump-down characteristics of a 100 l vessel at 50 Hz

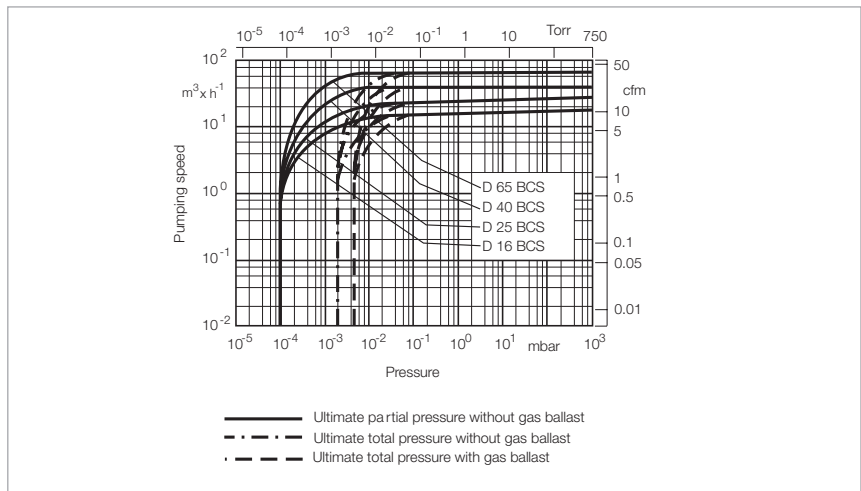

Pumping speed characteristics at 50 Hz (60 Hz curves at the end of the chapter)

Technical Data

TRIVAC D 16 BCS two-stage

D 25 BCS two-stage

		50 Hz	60 Hz	50 Hz	60 Hz
Nominal pumping speed ¹⁾	m ³ /h (cfm)	18.9 (11.1)	22.7 (13.4)	29.5 (17.4)	35.4 (20.9)
Pumping speed ¹⁾	m ³ /h (cfm)	16.5 (9.7)	19.8 (11.7)	25.7 (15.1)	30.8 (18.2)
Ultimate partial pressure without gas ballast ¹⁾	mbar (Torr)	10 ⁻⁴ (0.75 x 10 ⁻⁴)	10 ⁻⁴ (0.75 x 10 ⁻⁴)	10 ⁻⁴ (0.75 x 10 ⁻⁴)	10 ⁻⁴ (0.75 x 10 ⁻⁴)
Ultimate total pressure without gas ballast ¹⁾	mbar (Torr)	< 2.5 x 10 ⁻³ (< 1.9 x 10 ⁻³)	< 2.5 x 10 ⁻³ (< 1.9 x 10 ⁻³)	< 2.5 x 10 ⁻³ (< 1.9 x 10 ⁻³)	< 2.5 x 10 ⁻³ (< 1.9 x 10 ⁻³)
Ultimate total pressure with gas ballast ¹⁾	mbar (Torr)	< 5 x 10 ⁻³ (< 3.8 x 10 ⁻³)	< 5 x 10 ⁻³ (< 3.8 x 10 ⁻³)	< 5 x 10 ⁻³ (< 3.8 x 10 ⁻³)	< 5 x 10 ⁻³ (< 3.8 x 10 ⁻³)
Water vapor tolerance ¹⁾	mbar (Torr)	25 (18.8)	25 (18.8)	25 (18.8)	25 (18.8)
Water vapor capacity	g/h (lbs/h)	305 (0.672)	370 (0.816)	480 (1.058)	570 (1.257)
Oil filling, min. / max.	l (qt)	0.45 / 1.0 (0.5/1.1)	0.45 / 1.0 (0.5/1.1)	0.6 / 1.4 (0.6/1.5)	0.6 / 1.4 (0.6/1.5)
Noise level ²⁾ to DIN 45 635, without / with gas ballast	dB(A)	54 / 56	54 / 56	54 / 56	54 / 56
Admissible ambient temperature	°C (°F)	+12 to +40 (+54 to +104)	+12 to +40 (+54 to +104)	+12 to +40 (+54 to +104)	+12 to +40 (+54 to +104)
Motor rating ²⁾	W (HP)	750 (1)	750 (1)	750 (1)	750 (1)
Nominal speed ²⁾	rpm	1500	1800	1500	1800
Type of protection	IP	3)	3)	3)	3)
Weight ²⁾	kg (lbs)	28 (61.7)	28 (61.7)	32.9 (71.2)	32.9 (71.2)
Connections, Intake and Exhaust	DN	25 KF	25 KF	25 KF	25 KF

¹⁾ To DIN 28 400 and following numbers

²⁾ Motor rating and noise levels for the pumps with 3-phase motor 50 Hz.

Any data that deviate from the above for pumps with other motors, and other motor-dependent data are given in chapter "Products", paragraph "Motor Dependent Data for the TRIVAC B, BCS and BCS-PFPE"

³⁾ See paragraph "Motor Dependent Data for the TRIVAC B, BCS and BCS-PFPE"

Technical Data

TRIVAC

D 40 BCS two-stage

D 65 BCS two-stage

		50 Hz	60 Hz	50 Hz	60 Hz
Nominal pumping speed ¹⁾	m ³ /h (cfm)	46 (27)	55 (32.5)	75 (44)	90 (53)
Pumping speed ¹⁾	m ³ /h (cfm)	40 (24)	48 (28)	65 (38)	78 (46)
Ultimate partial pressure without gas ballast ¹⁾	mbar (Torr)	10 ⁻⁴ (0.75 x 10 ⁻⁴)	10 ⁻⁴ (0.75 x 10 ⁻⁴)	10 ⁻⁴ (0.75 x 10 ⁻⁴)	10 ⁻⁴ (0.75 x 10 ⁻⁴)
Ultimate total pressure without gas ballast ¹⁾	mbar (Torr)	< 2 x 10 ⁻³ (< 1.5 x 10 ⁻³)	< 2 x 10 ⁻³ (< 1.5 x 10 ⁻³)	< 2 x 10 ⁻³ (< 1.5 x 10 ⁻³)	< 2 x 10 ⁻³ (< 1.5 x 10 ⁻³)
Ultimate total pressure with gas ballast ¹⁾	mbar (Torr)	< 5 x 10 ⁻³ (< 3.8 x 10 ⁻³)	< 5 x 10 ⁻³ (< 3.8 x 10 ⁻³)	< 5 x 10 ⁻³ (< 3.8 x 10 ⁻³)	< 5 x 10 ⁻³ (< 3.8 x 10 ⁻³)
Water vapor tolerance ¹⁾	mbar (Torr)	40 (30)	40 (30)	40 (30)	40 (30)
Water vapor capacity	g/h (lbs/h)	1185 (2.612)	1420 (3.131)	1925 (4.244)	2310 (5.093)
Oil filling, min. / max.	l (qt)	1.7 / 2.6 (1.8/2.7)	1.7 / 2.6 (1.8/2.7)	2.0 / 3.3 (2.1/3.5)	2.0 / 3.3 (2.1/3.5)
Noise level ²⁾ to DIN 45 635, without / with gas ballast	dB(A)	57 / 59	57 / 59	57 / 59	57 / 59
Admissible ambient temperature	°C (°F)	+12 to +40 (+54 to +104)	+12 to +40 (+54 to +104)	+12 to +40 (+54 to +104)	+12 to +40 (+54 to +104)
Motor rating ²⁾	W (HP)	2200 (3)	2200 (3)	2200 (3)	2200 (3)
Nominal speed ²⁾	rpm	1500	1800	1500	1800
Type of protection	IP	3)	3)	3)	3)
Weight ²⁾	kg (lbs)	75.3 (166)	75.3 (166)	84.5 (186.3)	84.5 (186.3)
Connections, Intake and Exhaust	DN	40 KF	40 KF	40 KF	40 KF

¹⁾ To DIN 28 400 and following numbers

²⁾ Motor rating and noise levels for the pumps with 3-phase motor 50 Hz.

Any data that deviate from the above for pumps with other motors, and other motor-dependent data are given in chapter "Products", paragraph "Motor Dependent Data for the TRIVAC B, BCS and BCS-PFPE"

³⁾ See paragraph "Motor Dependent Data for the TRIVAC B, BCS and BCS-PFPE"

Ordering Information

**TRIVAC
D 16 BCS
two-stage**

**TRIVAC
D 25 BCS
two-stage**

**TRIVAC
D 40 BCS
two-stage**

**TRIVAC
D 65 BCS
two-stage**

	Part No.	Part No.	Part No.	Part No.
TRIVAC B with 3-phase motor 200-240 V (200 V IE3) / 380-400 V (380-400 V IE 3), 50 Hz / 200-240 (208-240 V IE3) / 380-480 V (416-480 V IE3), 60 Hz	113 68	113 78	113 88	113 98
200-346 V (IE3 Japan), 50 Hz / 220-380 V (IE3 Japan), 60 Hz	-	-	-	113 98J
Accessories				
Roots pump adaptor	-	-	168 30	168 30
Exhaust filter with lubricant return ARS 16-25	189 56	189 56	-	-
ARS 40-65	-	-	189 57	189 57
Condensate separator AK 16-25	188 11	188 11	-	-
AK 40-65	-	-	188 16	188 16
Chemical filter with safety blocking valve CFS 16-25	101 76	101 76	-	-
CFS 40-65	-	-	101 77	101 77
Inert gas system IGS 16-25	161 76	161 76	-	-
IGS 40-65	-	-	161 68V	161 68V
Limit switch system LSS 16-25	161 06	161 06	-	-
LSS 40-65	-	-	161 07	161 07
Spare Parts				
Inner body	200 39 762	200 39 764	200 39 758	200 39 760
Major maintenance kit for LVO 100 (without oil)	EK110002646	EK110002647	EK110002641	EK110002642
Minor maintenance kit for LVO 100 (without oil)	EK110002649	EK110002648	EK110002624	EK110002624
Shaft sealing replacement kit	EK110002650	EK110002650	EK110002643	EK110002643
Small parts kit	-	-	EK110002651	EK110002651
Seal kit	197 31	197 31	197 32	197 32

For further accessories see section "Accessories for TRIVAC E, B and BCS"

TRIVAC D 16 BCS-PFPE to D 65 BCS-PFPE

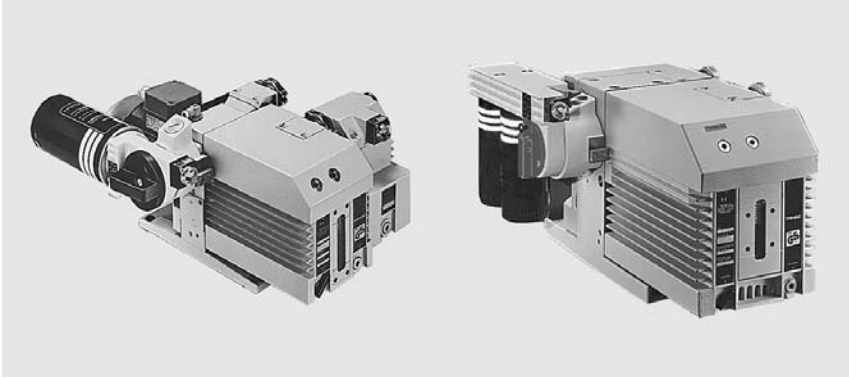

TRIVAC D 25 BCS-PFPE with CFS 16-25 and ARS 16-25 (left) and
TRIVAC D 65 BCS-PFPE with CFS 40-65 (right)

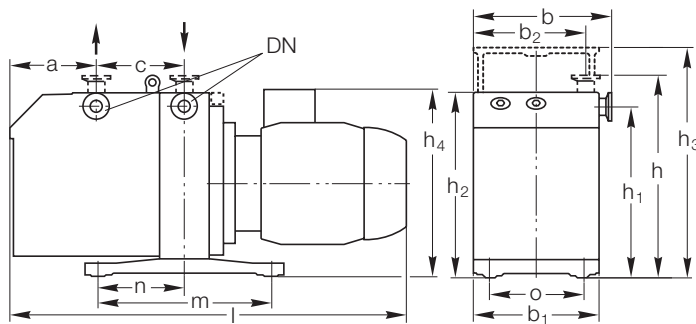

Type	DN	a	b	b ₁	b ₂	c	h	h ₁	h ₂	h ₃	h ₄	l	m	n	o	
D 16 BCS-PFPE (Part No. 113 69)	25 KF	mm	82	190	175	150	135	263	226	250	298	260	508	280	140	132
		in.	3.23	7.48	6.89	5.91	5.32	10.35	8.90	9.84	11.73	10.24	20.00	11.02	5.51	5.20
D 25 BCS-PFPE (Part No. 113 79)	25 KF	mm	142	190	175	150	135	263	226	250	298	260	570	280	140	132
		in.	5.59	7.48	6.89	5.91	5.32	10.35	8.90	9.84	11.73	10.24	22.44	11.02	5.51	5.20
D 40 BCS-PFPE (Part No. 113 89)	40 KF	mm	135	264	234	206	166	355	308	336	-	317	719	382	191	190
		in.	5.32	10.39	9.21	8.11	6.54	13.98	12.13	13.23	-	12.48	28.31	15.04	7.52	7.48
D 65 BCS-PFPE (Part No. 113 99)	40 KF	mm	213	264	234	206	166	355	308	336	-	317	794	382	191	190
		in.	8.39	10.39	9.21	8.11	6.54	13.98	12.13	13.23	-	12.28	31.26	15.04	7.52	7.48

¹⁾ For dimensions h₄ and l for further part numbers, see paragraph "Motor Dependent Data for the TRIVAC B, BCS and BCS-PFPE"

Dimensional drawing for the TRIVAC D 16 to D 65 BCS-PFPE

Technical Data

TRIVAC

D 16 BCS-PFPE two-stage

D 25 BCS-PFPE two-stage

		50 Hz	60 Hz	50 Hz	60 Hz
Nominal pumping speed ¹⁾	m ³ /h (cfm)	18.9 (11.1)	22.7 (13.4)	29.5 (17.4)	35.4 (20.9)
Pumping speed ¹⁾	m ³ /h (cfm)	16.5 (9.7)	19.8 (11.7)	25.7 (15.1)	30.8 (18.2)
Ultimate partial pressure without gas ballast ¹⁾	mbar (Torr)	< 8 x 10 ⁻⁴ (< 6 x 10 ⁻⁴)	< 8 x 10 ⁻⁴ (< 6 x 10 ⁻⁴)	< 8 x 10 ⁻⁴ (< 6 x 10 ⁻⁴)	< 8 x 10 ⁻⁴ (< 6 x 10 ⁻⁴)
Ultimate total pressure with gas ballast ¹⁾	mbar (Torr)	< 5 x 10 ⁻³ (< 3.8 x 10 ⁻³)	< 5 x 10 ⁻³ (< 3.8 x 10 ⁻³)	< 5 x 10 ⁻³ (< 3.8 x 10 ⁻³)	< 5 x 10 ⁻³ (< 3.8 x 10 ⁻³)
Ultimate total pressure with reduced gas ballast, 200 l/h ¹⁾	mbar (Torr)	< 2 x 10 ⁻³ (< 1.5 x 10 ⁻³)	< 2 x 10 ⁻³ (< 1.5 x 10 ⁻³)	< 2 x 10 ⁻³ (< 1.5 x 10 ⁻³)	< 2 x 10 ⁻³ (< 1.5 x 10 ⁻³)
Lubricant filling					
min. / max. upon delivery	l (qt)	0.45 / 1.0 (0.5 / 1.1)	0.45 / 1.0 (0.5 / 1.1)	0.6 / 1.4 (0.6 / 1.5)	0.6 / 1.4 (0.6 / 1.5)
	l (qt)	0.2 (0.2)	0.2 (0.2)	0.4 (0.4)	0.4 (0.4)
Noise level ²⁾ to DIN 45 635, without / with gas ballast	dB(A)	54 / 56	54 / 56	54 / 56	54 / 56
Admissible ambient temperature	°C (°F)	+12 to +40 (+54 to +104)	+12 to +40 (+54 to +104)	+12 to +40 (+54 to +104)	+12 to +40 (+54 to +104)
Motor rating ²⁾	W (HP)	750 (1)	750 (1)	750 (1)	750 (1)
Nominal speed ²⁾	rpm	1500	1800	1500	1800
Type of protection	IP	³⁾	³⁾	³⁾	³⁾
Weight ²⁾	kg (lbs)	29.3 (64.5) ⁴⁾	29.3 (64.5) ⁴⁾	33.8 (74.4) ⁴⁾	33.8 (74.4) ⁴⁾
Connections, Intake and Exhaust	DN	25 KF	25 KF	25 KF	25 KF

¹⁾ To DIN 28 400 and following numbers

²⁾ Motor rating and noise levels for the pumps with 3-phase motor 50 Hz.

Any data that deviate from the above for pumps with other motors, and other motor-dependent data are given in chapter "Products", paragraph "Motor Dependent Data for the TRIVAC B, BCS and BCS-PFPE"

³⁾ See paragraph "Motor Dependent Data for the TRIVAC B, BCS and BCS-PFPE"

⁴⁾ Upon delivery

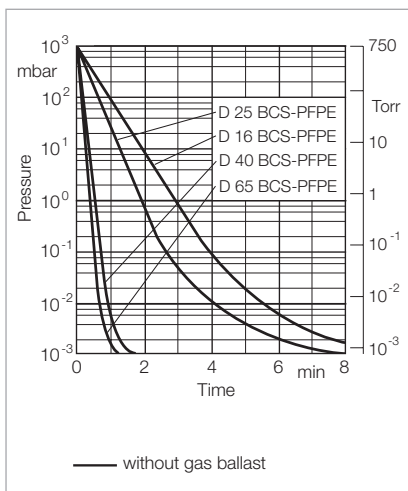

Pump-down characteristics of a 100 l vessel at 50 Hz

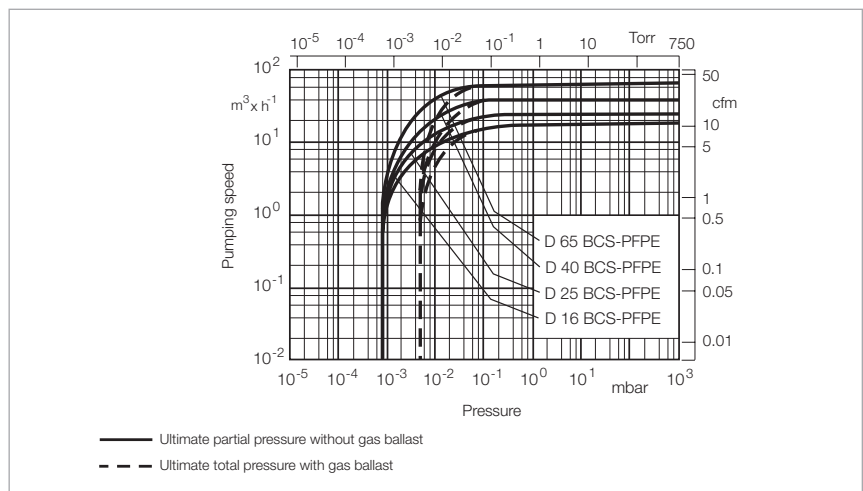

Pumping speed characteristics at 50 Hz (60 Hz curves at the end of the chapter)

Technical Data

TRIVAC

D 40 BCS-PFPE two-stage

D 65 BCS-PFPE two-stage

		50 Hz	60 Hz	50 Hz	60 Hz
Nominal pumping speed ¹⁾	m ³ /h (cfm)	46 (27)	55 (32.5)	75 (44)	90 (53)
Pumping speed ¹⁾	m ³ /h (cfm)	40 (24)	48 (28)	65 (38)	78 (46)
Ultimate partial pressure without gas ballast ¹⁾	mbar (Torr)	< 8 x 10 ⁻⁴ (< 6 x 10 ⁻⁴)	< 8 x 10 ⁻⁴ (< 6 x 10 ⁻⁴)	< 8 x 10 ⁻⁴ (< 6 x 10 ⁻⁴)	< 8 x 10 ⁻⁴ (< 6 x 10 ⁻⁴)
Ultimate total pressure with gas ballast ¹⁾	mbar (Torr)	< 5 x 10 ⁻³ (< 3.8 x 10 ⁻³)	< 5 x 10 ⁻³ (< 3.8 x 10 ⁻³)	< 5 x 10 ⁻³ (< 3.8 x 10 ⁻³)	< 5 x 10 ⁻³ (< 3.8 x 10 ⁻³)
Lubricant filling					
min. / max.	l (qt)	1.7 / 2.6 (1.8 / 2.7)	1.7 / 2.6 (1.8 / 2.7)	2.0 / 3.3 (2.1 / 3.5)	2.0 / 3.3 (2.1 / 3.5)
upon delivery	l (qt)	0.6 (0.6)	0.6 (0.6)	0.75 (0.8)	0.75 (0.8)
Noise level ²⁾ to DIN 45 635, without / with gas ballast	dB(A)	57 / 59	57 / 59	57 / 59	57 / 59
Admissible ambient temperature	°C (°F)	+12 to +40 (+54 to +104)	+12 to +40 (+54 to +104)	+12 to +40 (+54 to +104)	+12 to +40 (+54 to +104)
Motor rating ²⁾	W (HP)	2200 (3)	2200 (3)	2200 (3)	2200 (3)
Nominal speed ²⁾	rpm	1500	1800	1500	1800
Type of protection	IP	³⁾	³⁾	³⁾	³⁾
Weight ²⁾	kg (lbs)	77.9 (171.8) ⁴⁾	77.9 (171.8) ⁴⁾	87.9 (193.7) ⁴⁾	87.9 (193.7) ⁴⁾
Connections, Intake and Exhaust	DN	40 KF	40 KF	40 KF	40 KF

¹⁾ To DIN 28 400 and following numbers

²⁾ Motor rating and noise levels for the pumps with 3-phase motor 50 Hz.

Any data that deviate from the above for pumps with other motors, and other motor-dependent data are given in chapter "Products", paragraph "Motor Dependent Data for the TRIVAC B, BCS and BCS-PFPE"

³⁾ See paragraph "Motor Dependent Data for the TRIVAC B, BCS and BCS-PFPE"

⁴⁾ Upon delivery

Ordering Information

TRIVAC
D 16 BCS-PFPE
two-stage

TRIVAC
D 25 BCS-PFPE
two-stage

TRIVAC
D 40 BCS-PFPE
two-stage

TRIVAC
D 65 BCS-PFPE
two-stage

	Part No.	Part No.	Part No.	Part No.
TRIVAC BCS-PFPE with 3-phase motor 200-240 V (200 V IE3) / 380-400 V (380-400 V IE3), 50 Hz / 200-240 (208-240 V IE3) / 380-480 V (416-480 V IE3), 60 Hz	113 69	113 79	113 89	113 99
Accessories				
Roots pump adaptor	-	-	168 30	168 30
Exhaust filter with lubricant return ARS 16-25 ARS 40-65	189 56 -	189 56 -	- 189 57	- 189 57
Condensate trap AK 16-25 AK 40-65	188 11 -	188 11 -	- 188 16	- 188 16
Chemical filter with safety isolation valve CFS 16-25 CFS 40-65	101 76 -	101 76 -	- 101 77	- 101 77
Inert gas system IGS 16-25 IGS 40-65	161 76 -	161 76 -	- 161 68V	- 161 68V
Limit switch system LSS 16-25 LSS 40-65	161 06 -	161 06 -	- 161 07	- 161 07
Spare Parts				
Major maintenance kit, LVO 400 (without oil)	EK110002644	EK110002645	EK110002637	EK110002638
Shaft sealing replacement kit	EK110002650	EK110002650	EK110002643	EK110002643
Small parts kit	-	-	EK110002651	EK110002651
Seal kit	197 41	197 41	197 42	197 42

For further accessories see section "Accessories for TRIVAC E, B and BCS"

Only available for purchase in North and South America



Ordering Information

TRIVAC
D 16 BCS-PFPE
two-stage

D 25 BCS-PFPE
two-stage





	Part No.	Part No.
TRIVAC BCS-PFPE with 1-phase motor 220-230 V, 50/60 Hz, NEMA plug	-	913 79-2





Motor Dependent Data for the TRIVAC B, BCS and BCS-PFPE

Pump type	D 4 / 8 B		D 4 / 8 B	
Part No. of the pump	140 081, 140 082		112 45, 112 55	
Motor part number	10002292		6507733	
Size	80		71	
Protection class	IP 54		IP 55	
Operating mode in acc. w. IEC 34 / NEMA	S1			
Insulation class	F			
Phases	1~		3~	
Efficiency class	-			
Number of poles	4			
Nominal output power at 50 Hz at 60 Hz	570 W 660 W		370 W -	
Nominal input frequency	50 Hz / 60 Hz		50 Hz / 60 Hz	
Nominal voltage range and nominal current (Mains voltage tolerance $\pm 10\%$) at 50 Hz	100-115 V / 7.7 A -		230 V / 3.0 A -	
	210-230 V / 4.0 A -		380-400 V / 1.07 A -	
at 60 Hz	100-115 V / 5.6 A -		200-240 V / 2.15 A -	
	210-230 V / 2.8 A -		380-480 V / 1.07 A -	
Nominal speed 50 Hz 60 Hz	rpm 1420 rpm 1690		1410 -	
Maximum operating altitude above sea level	1000 m			
Max. ambient temperature during operation	°C (°F) 40 (104)			
Terminal board / plug	Multi-pin plug at junction box, mains cord 20081091 (1.8 m) with Schuko plug CEE 7/7 (Included in delivery), mains cord 20081097 (1.8 m) with UK plug BS 1363 (optional), mains cord 20081099 (1.8 m) with CH plug SEV 1011 (optional), mains cord 20081141 (1.8 m) with US plug NEMA 6-15P (optional), mains cord 20081090 (1.8 m) with US plug NEMA 5-15P (100-120 V) (optional)		mains cord (2 m) with Schuko plug CEE	
			9 pins	
			6 pins	
Certifications				
			 II 2 G Ex e II T3	
Shaft dimension $\varnothing d / l$	mm (in.)		14 / 30 (0.55 / 1.18)	
Size of flange A/B	mm (in.)		140 / 95 (5.51 / 3.74)	
Length of the pump	mm (in.)		480 (18.90) (D 4 B) 504 (19.84) (D 8 B)	
Height up to top edge of junction box h_4	mm (in.)		254 (10.0) 258 (10.16)	
			247 (9.72) 241 (9.49)	



Only available for purchase in North and South America

Pump type		D 4 B	D 8 B
Part No. of the pump		898 973	898 974
Motor part number		72260195	72260196
Size		56C	
Protection class		TEFC	
Operating mode in acc. w. IEC 34 / NEMA		continuous	
Insulation class		B	
Phases		1~	
Efficiency class		-	
Number of poles		4	
Nominal output power at 50 Hz at 60 Hz		180 W 240 W	240 W 370 W
Nominal input frequency		50 Hz / 60 Hz	
Nominal voltage range and nominal current (Mains voltage tolerance $\pm 10\%$) at 50 Hz		110 V / 6.8 A - 220 V / 3.4 A -	110 V / 9.6 A - 220 V / 4.8 A -
at 60 Hz		115 V / 6.0 A - 208-230 V / 3.1 A -	115 V / 8.8 A - 208-230 V / 4.5 A -
Nominal speed 50 Hz 60 Hz	rpm rpm	1425 1725	
Maximum operating altitude above sea level		1000 m	
Max. ambient temperature during operation	°C (°F)	40 (104)	
Terminal board / plug		40 (104) 12 pin plug at the motor, mains cord (1.8 m) 721 27 874 with US plug NEMA 5-15P (115 V) (optional)	
Certifications			
Shaft dimension $\varnothing d / l$	mm (in.)	15.87 / 52.32 (0.625 / 2.06)	
Size of flange A/B	mm (in.)	114.3 (4.5)	
Length of the pump	mm (in.)	464 (18.27) (D 4 B)	488 (19.21) (D 8 B)
Height up to top edge of junction box h_4	mm (in.)	252 (9.92)	287 (11.30)

Pump type	D 16 / 25 B D 16 / 25 BCS D 16 / 25 BCS-PFPE D 16 / 25 B-DOT	D 16 / 25 B	D 16 / 25 B (3i/3o)	D 16 B-Ex
Part No. of the pump	112 66, 112 76, 113 33 914 63-1 112 68, 112 78 112 69, 112 79 114 06, 114 10, 112 76 18	112 66J, 112 76J, 113 33J	140 160, 140 170	140 091, 140 092
Motor part number	E6506939	6520730	20010409	2100002330
Size	80	80Z	80L	80L
Protection class	IP 55			
Operating mode in acc. w. IEC 34 / NEMA	S1			
Insulation class	F			
Phases	3~			
Efficiency class	IE3	IE3 Japan	-	-
Number of poles	4			
Nominal output power at 50 Hz at 60 Hz	750 W 750 W	750 W 750 W	750 W -	750 W -
Nominal input frequency	50 Hz / 60 Hz	50 Hz / 60 Hz	-	-
Nominal voltage range and nominal current (Mains voltage tolerance $\pm 10\%$) at 50 Hz bei 60 Hz	200-240 V / 3.6 A 200 V / 3.6 A (IE3) 380-400 V / 1.8 A 380-400 V / 1.8 A (IE3) 200-240 V / 3.4 A 208-240 V / 3.2 A (IE3) 380-480 V / 1.7 A 416-480 V / 1.6 A (IE3)	200-346 V (IE3 Japan) - - - 200-350 V 220-380 V (IE3 Japan) - -	230 V / 3.35 A - 400 V / 1.94 A - - - - -	230 V / 3.4 A - 400 V / 1.95 A - - - - -
Nominal speed 50 Hz 60 Hz	rpm rpm	1430 1740	1440 1745	1380 -
Maximum operating altitude above sea level	1000 m			
Max. ambient temperature during operation	$^{\circ}\text{C}$ ($^{\circ}\text{F}$) 40 (104)			
Terminal board / plug	9 pins	9 pins	6 pins	6 pins
Certifications				
Shaft dimension $\varnothing d / l$	mm (in.)	19 / 40 (0.75 / 1.58)		
Size of flange A/B	mm (in.)	160 / 110 (6.30 / 4.33)		
Length of the pump	mm (in.)	508 (20.0) (D 16 B) 570 (22.44) (D 25 B)	508 (20.0) (D 16 B) 570 (22.44) (D 25 B)	510 (20.08) (D 16 B) 572 (22.52) (D 25 B)
Height up to top edge of junction box h_4	mm (in.)	260 (10.24)	260 (10.24)	268 (10.55)



Pump type		D 16 / 25 B	D 16 / 25 B	D 16 B
Part No. of the pump		112 65, 112 75	113 25, 113 35	898 698
Motor part number		E38066003	E110001212	72260187
Size		90	90	56C
Protection class		IP 44	IP 54	IP44
Operating mode in acc. w. IEC 34 / NEMA		S1	H	continuous
Insulation class		F	F	F
Phases		1~	1~	1~
Efficiency class		-	-	-
Number of poles		4	4	4
Nominal output power at 50 Hz at 60 Hz		750 W 750 W	750 W 750 W	750 W 750 W
Nominal input frequency		50 Hz / 60 Hz	50 Hz / 60 Hz	50 Hz / 60 Hz
Nominal voltage range and nominal current (Mains voltage tolerance $\pm 10\%$) at 50 Hz ¹⁾		230 V / 5.6 A - - -	230 V / 5.7 A - - -	110 V / 15.0 A - 220 V / 7.5 A -
at 60 Hz ¹⁾		230 V / 5.7 A - - -	230 V / 4.9 A - - -	115 V / 12.4 A - 208-230 V / 6.3-6.2 A -
Nominal speed 50 Hz 60 Hz	rpm rpm	1460 1750	1420 1680	1500 1800
Maximum operating altitude above sea level		1000 m	1000 m	1000 m
Maximum ambient temperature during operation	°C (°F)	40 (104)	40 (104)	40 (104)
Terminal board		mains cord (2 m) with Schuko plug CEE	Multi-pin plug at junction box, mains cord 20081091 (1.8 m) with Schuko plug CEE 7/7 (Included in delivery), mains cord 20081097 (1.8 m) with UK plug BS 1363 (optional), mains cord 20081099 (1.8 m) with CH plug SEV 1011 (optional), mains cord 20081141 (1.8 m) with US plug NEMA 6-15P (230 V) (optional)	Multi-pin plug at junction box, mains cord (1.8 m) E72127877 with US plug NEMA 5-15P (115 V), mains cord (1.8 m) E72127878 with US plug NEMA 6-15P (230 V)
Certifications				  
Shaft dimension $\varnothing d / l$	mm (in.)	19 / 40 (0.75 / 1.58)	19 / 40 (0.75 / 1.58)	15.87 / 53.32 (0.625 / 2.06)
Size of flange A/B	mm (in.)	160 / 110 (6.30 / 4.33)	160 / 110 (6.30 / 4.33)	114.3 (4.5)
Length of the pump	mm (in.)	521 (20.51) (D 16 B) 583 (22.95) (D 25 B)	505 (19.88) (D 16 B) 567 (22.32) (D 25 B)	582 (22.91) (D 16 B) -
Height up to top edge of junction box h_4	mm (in.)	278 (10.95)	279 (10.98)	263 (10.35)

Only available for purchase in North and South America

Pump type		D 16 B	D 16 B
Part No. of the pump		898 208, 912 65-1	912 65-2
Motor part number		72260117	72260005
Size		56C	56C
Protection class		IP 43	TEFC
Operating mode in acc. w. IEC 34 / NEMA		continuous	continuous
Insulation class		F	B3
Phases		1~	1~
Efficiency class		-	-
Number of poles		4	4
Nominal output power			
at 50 Hz		560	550 W
at 60 Hz		560	550 W
Nominal input frequency		50 Hz / 60 Hz	50 Hz / 60 Hz
Nominal voltage range and nominal current (Mains voltage tolerance $\pm 10\%$)			
at 50 Hz ¹⁾		115 V / 13.0 A - 208-230 V / 5.5-6.5 A -	208-230 V / 5.5-6.5 A - - -
at 60 Hz ¹⁾		115 V / 9.4 A - 208-230 V / 4.8-7.4 A -	208-230 V / 4.8-4.7 A - - -
Nominal speed			
50 Hz	rpm	1425	1500
60 Hz	rpm	1725	1800
Maximum operating altitude above sea level		1000 m	1000 m
Maximum ambient temperature during operation	°C (°F)	40 (104)	40 (104)
Terminal board		mains cord (1.8 m) with US plug NEMA 5-15P (115 V)	mains cord (1.8 m) with plug NEMA 6-15P (230 V)
Certifications			
Shaft dimension $\varnothing d / l$	mm (in.)	15.87 / 53.32 (0.625 / 2.06)	15.87 / 53.32 (0.625 / 2.06)
Size of flange A/B	mm (in.)	114.3 (4.5)	114.3 (4.5)
Length of the pump	mm (in.)	624 (24.57) (D 16 B)	538 (21.18) (D 16 B)
Height up to top edge of junction box h_4	mm (in.)	265 (10.43)	247 (9.72)

Only available for purchase in North and South America

Pump type	D 25 B	D 25 B - PFPE
Part No. of the pump	912 75-2, 913 79-2	170 119
Motor part number	72260022	190260213
Size	–	56C
Protection class	IP 44	TEFC
Operating mode in acc. w. IEC 34 / NEMA	continuous	continuous
Insulation class	F	F
Phases	1~	1~
Efficiency class	–	–
Number of poles	4	4
Nominal output power at 50 Hz at 60 Hz	1100 1100	– 1100
Nominal input frequency	50 Hz / 60 Hz	60 Hz
Nominal voltage range and nominal current (Mains voltage tolerance $\pm 10\%$) at 50 Hz	220-230 V / 9.6-9.2 A – – –	– – – –
at 60 Hz	220-230 V / 9.6-8.0 A – – –	115 V / 18.0 A – 208-230 V / 8.4-8.0 A –
Nominal speed 50 Hz rpm 60 Hz rpm	1425 1725	– 1725
Maximum operating altitude above sea level	1000 m	1000 m
Maximum ambient temperature during operation °C (°F)	40 (104)	40 (104)
Terminal board	mains cord (1.8 m) with plug NEMA 6-15P (230 V)	9 wires
Certifications		
Shaft dimension $\varnothing d / l$ mm (in.)	15.87 / 53.32 (0.625 / 2.06)	15.87 / 53.32 (0.625 / 2.06)
Size of flange A/B mm (in.)	114.3 (4.5)	114.3 (4.5)
Length of the pump mm (in.)	639 (25.16) (D 25 B)	644 (25.35) (D 25 B)
Height up to top edge of junction box h_4 mm (in.)	265 (10.43)	263 (10.35)

Pump type	D 40 / 65 B D 40 / 65 BCS D 40 / 65 BCS-PFPE D 40 B-DOT + D 65 B ³He		D 40 / 65 B	D 40 / 65 B-Ex
Part No. of the pump	112 86, 112 96 113 88, 113 98 113 89, 113 99 112 86 12 / 112 96 46		112 86J, 112 96J, 112 98J	140 180, 140 190
Motor part number	E6506961		6520731	20010411
Size	100L			
Protection class	IP 55			
Operating mode in acc. w. IEC 34 / NEMA	S1			
Insulation class	F			
Phases	3~			
Efficiency class	IE3	IE3 Japan	-	
Number of poles	4			
Nominal output power at 50 Hz at 60 Hz	2200 W 2200 W	2200 W 2200 W	2600 W -	
Nominal input frequency	50 Hz / 60 Hz		50 Hz / 60 Hz	
Nominal voltage range and nominal current (Mains voltage tolerance ±10 %) at 50 Hz bei 60 Hz	200-240 V / 15.0 A 200 V / 10.4 A (IE3) 380-400 V / 5.2A 380-400 V / 5.2A (IE3) 200-240 V / 12.0 A 208-240 V / 9.2 A (IE3) 380-480 V / 5.2 A 416-480 V / 4.6 A (IE3)	200-346 V (IE3 Japan) - - - - 220-380 V (IE3 Japan) - -	230 V / 3.35 A - 400 V / 1.94 A - - - -	
Nominal speed 50 Hz 60 Hz	rpm rpm	1430 1735	1460 1760	1420 -
Maximum operating altitude above sea level	1000 m			
Max. ambient temperature during operation	°C (°F) 40 (104)			
Terminal board / plug	9 pins		9 pins	6 pins
Certifications				
Shaft dimension $\varnothing d / l$	mm (in.)	28 / 60 (1.10 / 2.36)		
Size of flange A/B	mm (in.)	160 / 110 (6.30 / 4.33)		
Length of the pump	mm (in.)	719 (28.31) (D 40 B) 794 (31.26) (D 65 B)		
Height up to top edge of junction box h_4	mm (in.)	317 (12.48)	317 (12.48)	328 (12.91)

Accessories

For TRIVAC E, B and BCS

Exhaust Filters AF 8 to AF 25 Condensate Traps AK 8 to AK 25



Exhaust filter (left) and condensate trap (right)

Exhaust-Filter

Oil mists and aerosols are retained in the exhaust filter.

Advantages to the User

- Filtering of the exhaust gas by removal of entrained lubricant particles
- Emptying via drain screw or exhaust filter drain tap
- Separation efficiency > 99%
- Filter elements (made of glass fiber) are exchangeable

Condensate Trap

Condensate traps prevent the formation of condensate in the pump as well as the backstreaming of fluids.

Advantages to the User

- Can be connected to either the intake or the exhaust side
- Protects against condensate forming from sucked in vapors or gases (intake line)
- Protects against backstreaming liquids (exhaust line)
- Emptying via drain screw/drain tap

Technical Information

The exhaust filter is not capable of retaining toxic and/or aggressive gases. For such applications we recommend the use of an exhaust gas line (e.g. a gas washer).

Since the material is not resistant to all gases and solvents, a materials compatibility chart is available upon request.

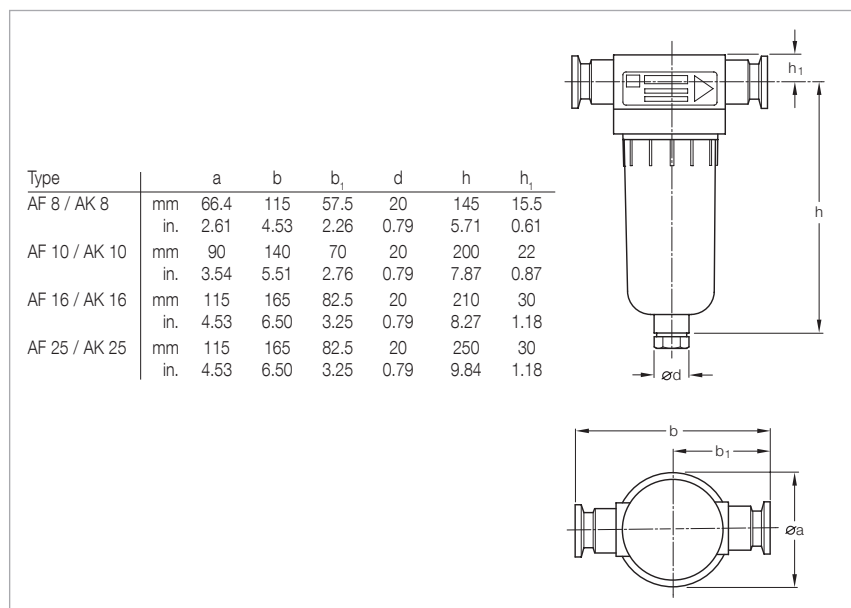

Dimensional drawing for the AF exhaust filter and AK condensate trap

Technical Data

AF 8 AK 8 AF 10 AK 10 AF 16 AK 16 AF 25 AK 25

Connection to pump (required accessories for TRIVAC E: elbow)	TRIVAC	D 2,5 E D 4 B D 8 B	D 2,5 E D 4 B D 8 B	D 16 B	D 16 B	D 16 B	D 16 B	D 16 B D 25 B	D 16 B D 25 B
Connection flanges	DN	16 KF	16 KF	25 KF	25 KF	25 KF	25 KF	25 KF	25 KF
Max. filling level (for vertical installation)	ml	60	60	145	145	285	285	285	285
Permissible leak rate	mbar x l/s	$\leq 1 \times 10^{-5}$	$\leq 1 \times 10^{-5}$	$\leq 1 \times 10^{-5}$	$\leq 1 \times 10^{-5}$	$\leq 1 \times 10^{-5}$	$\leq 1 \times 10^{-5}$	$\leq 1 \times 10^{-5}$	$\leq 1 \times 10^{-5}$
Max. continuous temperature	°C (°F)	90 (194)	90 (194)	90 (194)	90 (194)	90 (194)	90 (194)	90 (194)	90 (194)
Material		Polyamide 6	Polyamide 6	Polyamide 6	Polyamide 6	Polyamide 6	Polyamide 6	Polyamide 6	Polyamide 6

Ordering Information

AF 8 AK 8 AF 10 AK 10 AF 16 AK 16 AF 25 AK 25

	Part No.	Part No.	Part No.	Part No.	Part No.	Part No.	Part No.	Part No.
Exhaust filter	190 50	-	190 51	-	190 52	-	190 53	-
Exhaust filter drain tap	190 95	190 95	190 95	190 95	190 95	190 95	190 95	190 95
Condensate trap	-	190 60	-	190 61	-	190 62	-	190 63
Replacement filter element (pack of 5)								
FE 8	ES 190 80	-	-	-	-	-	-	-
FE 10	-	-	ES 190 81	-	-	-	-	-
FE 16	-	-	-	-	ES 190 82	-	-	-
FE 25	-	-	-	-	-	-	ES 190 83	-
Reducer DN 25/16 KF ¹⁾								
Aluminium (if necessary)	183 86	183 86	183 86	183 86	183 86	183 86	183 86	183 86
Elbow (1x)								
Aluminium	184 36	184 36	184 37	184 37	184 37	184 37	184 37	184 37
Centering ring with O-ring (2x)								
Aluminium / NBR	183 26	183 26	183 27	183 27	183 27	183 27	183 27	183 27
Stainless steel / FPM (FKM)	883 46	883 46	883 47	883 47	883 47	883 47	883 47	883 47
Clamping ring (2x)	183 41	183 41	183 42	183 42	183 42	183 42	183 42	183 42

¹⁾ When using the reducer, an elbow is required

Exhaust Filters

AF 4-8 to AF 40-65

AF 16-25 DOT and AF 40-65 DOT



AF 4-8 exhaust filter

Exhaust filters retain oil mists and aerosols.

Advantages to the User

- Can be fitted without additional accessories
- Separation efficiency over 99 %
- Exchangeable filter inserts
- Built-in over-pressure relief valve (threshold at about 1.5 bar (7.2 psi, differential))
- Sight glass for checking of the quantity of collected oil
- Resistant against solvents
- Seals for
 - AF made of FPM (FKM)
 - AF-DOT made of EPDM
- Easy to clean and use
- Retains dirt and cracked products

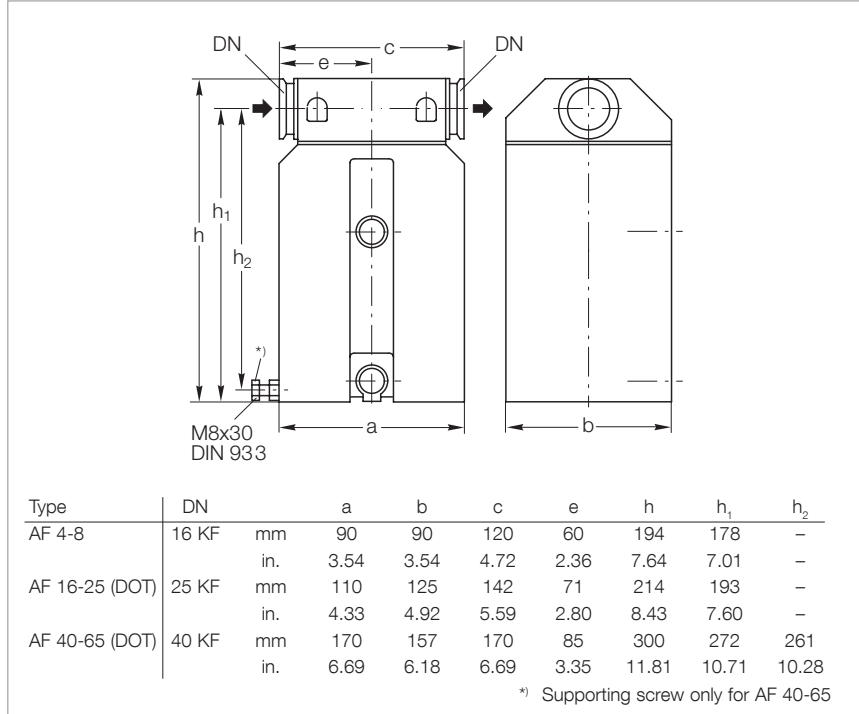

Dimensional drawing for the AF exhaust filters

Typical Application

- Improvement of oil separating capacity

Technical Information

An exhaust line must be connected in case of hazardous exhaust gases.

Technical Data**AF 4-8****AF 16-25****AF 40-65**

Connection to pump	TRIVAC	D 4/8 B	D 16/25 B/BCS	D 40/65 B/BCS
Max. capacity for condensate, approx.	l (qt)	0.4 (0.45)	0.5 (0.57)	1.0 (1.14)
Weight	kg (lbs)	1.9 (4.1)	3.2 (7.1)	6.5 (14.3)

Ordering Information**AF 4-8****AF 16-25****AF 40-65**

	Part No.	Part No.	Part No.
Exhaust filter	189 06	189 11	189 16
Replacement filter element			
FE 4-8	189 71	-	-
FE 16-25	-	189 72	-
FE 40-65	-	-	189 73
Oil drain tap M 16 x 1.5 (vacuum-tight)	190 90	190 90	190 90

Technical Data**AF 16-25 DOT****AF 40-65 DOT**

Connection to pump	TRIVAC	-	D 16/25 B-DOT	D 40 B-DOT
--------------------	--------	---	---------------	------------

Ordering Information**AF 16-25 DOT****AF 40-65 DOT**

	Part No.	Part No.	Part No.
Exhaust filter DOT	-	124 16	101 15
Replacement filter element			
FE 16-25 DOT	-	200 10 304	-
FE 40-65 DOT	-	-	200 39 840 ¹⁾

¹⁾ 2 pieces are required

Exhaust Filters with Lubricant Return ARP 4-8 and AR 4-8 to AR 40-65



AR 4-8 exhaust filter with lubricant return



ARP 4-8 exhaust filter with lubricant return

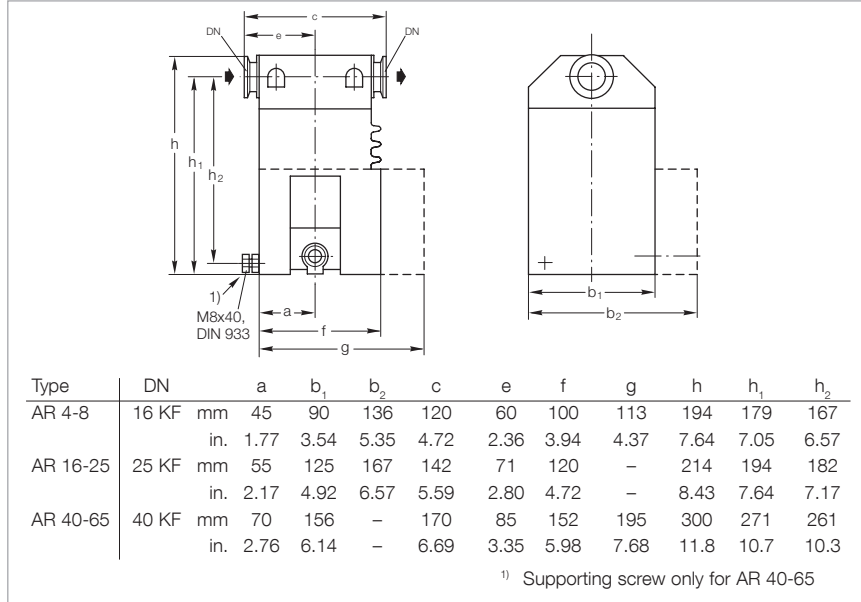

Dimensional drawing for the AR exhaust filters with lubricant return
(dimensions for the ARP exhaust filter with lubricant return upon request)

This combination of an exhaust filter with a float-controlled valve considerably extends the maintenance intervals for the TRIVAC pumps.

Advantages to the User

- Filtering the exhaust air of entrained lubricant particles
- Lubricant return with the aid of a float-controlled valve back into the intake port
- No operating costs caused by lost lubricant
- Hardly any oil consumption
- Standard filter element
- Built-in over-pressure relief valve
- Resists solvents
- All seals made of FPM (FKM)
- Easy change of the return port for horizontal or vertical connection

Typical Application

- Extending the maintenance intervals

Supplied Equipment

Intermediate flange, connecting lines with hollow screws, required gaskets as well as mounting screws for the intake flange.

Technical Data

ARP 4-8 AR 4-8 AR 16-25 AR 40-65

Connection to pump	TRIVAC	D 4/8 B	D 4/8 B	D 16/25 B/BCS	D 40/65 B/BCS
For opening the float-controlled valve required amount of oil					
LEYBONOL LVO 100	cm ³ (qt)	-	430 (0.45)	510 (0.54)	760 (0.80)
LEYBONOL LVO 400	cm ³ (qt)	-	350 (0.37)	430 (0.45)	700 (0.74)
Remaining amount of oil					
LEYBONOL LVO 100	cm ³ (qt)	-	290 (0.31)	340 (0.36)	420 (0.44)
LEYBONOL LVO 400	cm ³ (qt)	-	250 (0.26)	300 (0.32)	390 (0.41)
Weight	kg (lbs)	1.7 (3.8)	3.1 (6.89)	4.7 (10.4)	8.5 (18.7)

Ordering Information

ARP 4-8 AR 4-8 AR 16-25 AR 40-65

	Part No.	Part No.	Part No.	Part No.
Exhaust filter with lubricant return	140 065	189 20	189 21	189 22
Replacement filter element				
FE 8	190 80	-	-	-
FE 4-8	-	189 71	-	-
FE 16-25	-	-	189 72	-
FE 40-65	-	-	-	189 73

Technical Information

The AR is connected to the exhaust port of the TRIVAC B, the return line is connected at the intermediate flange under the intake port. An exhaust line must be connected in case of hazardous exhaust gases.

The ARP and AR filters are factory cleaned to such an extent, that they may be operated either with mineral oil (e.g. LEYBONOL LVO 100) or perfluoropolyether (PFPE) (e.g. LEYBONOL LVO 400).

Exhaust Filters with Lubricant Return ARS 16-25 and ARS 40-65



ARS 40-65

This combination of an exhaust filter with a float-controlled valve considerably extends the maintenance intervals of the TRIVAC BCS.

The ARS is part of the TRIVAC SYSTEM.

Advantages to the User

- Lubricant return with the aid of a float-controlled valve back into the intake port
- The intake port may be easily exchanged (either vertical or horizontal orientation)
- No operating costs caused by lost lubricant
- Hardly any oil consumption
- Visual indication of the differential pressure
- Standard filter element
- All aluminium parts are surface protected
- Built-in over-pressure relief valve
- Resists solvents
- All seals made of FPM (FKM)

Typical Application

- Filtering the exhaust air of entrained lubricant particles

Supplied Equipment

Intermediate flange, connecting lines with hollow screws, required gaskets as well as mounting screws for the intake flange.

Wrapped in foil for shipping.

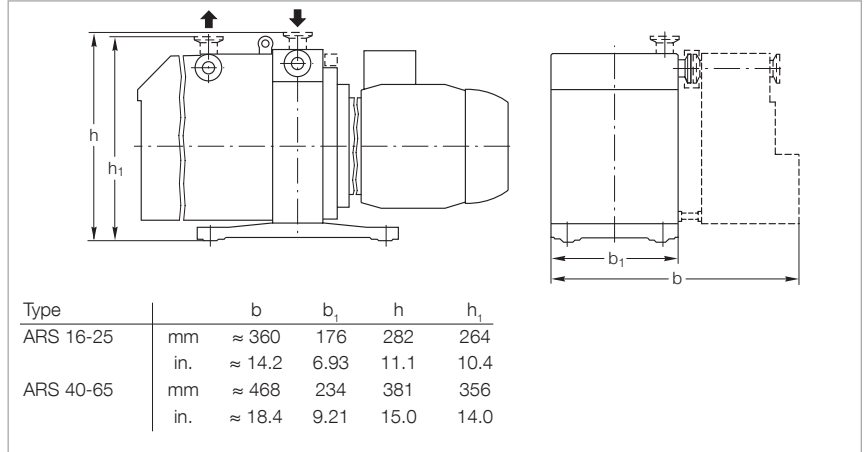

Dimensional drawing for the ARS mounted on a TRIVAC BCS

Technical Information

An exhaust line must be connected in case of hazardous exhaust gases. The ARS is connected to the exhaust port of the TRIVAC BCS, the return line is connected at the intermediate flange under the intake port.

The ARS is factory cleaned to such an extent, that it may be operated either with mineral oil (e.g. LEYBONOL LVO 100) or perfluoropolyether (PFPE) (e.g. LEYBONOL LVO 400).

Technical Data

ARS 16-25

ARS 40-65

Connection to pump	TRIVAC	D 16/25 B D 16/25 BCS (-PFPE)	D 40/65 B D 40/65 BCS (-PFPE)
Connection flanges	DN	25 KF	40 KF
Amount of oil required for opening the float-controlled valve			
LEYBONOL LVO 100	cm ³ (qt)	510 (0.54)	760 (0.80)
LEYBONOL LVO 400	cm ³ (qt)	340 (0.36)	420 (0.44)
Remaining amount of oil			
LEYBONOL LVO 100	cm ³ (qt)	430 (0.45)	700 (0.74)
LEYBONOL LVO 400	cm ³ (qt)	300 (0.31)	390 (0.41)
Weight with intermediate flange, tubing and filter, without lubricant	kg (lbs)	4.7 (10.4)	8.5 (16.7)

Ordering Information

ARS 16-25

ARS 40-65

	Part No.	Part No.
Exhaust filter with lubricant return	189 56	189 57
Replacement filter element		
FE 16-25	189 72	-
FE 40-65	-	189 73

Exhaust Filter Drain Tap



The exhaust filter drain tap simplifies draining of the oil from the exhaust filter.

Technical Note

May also be used in connection with the condensate separator AK.

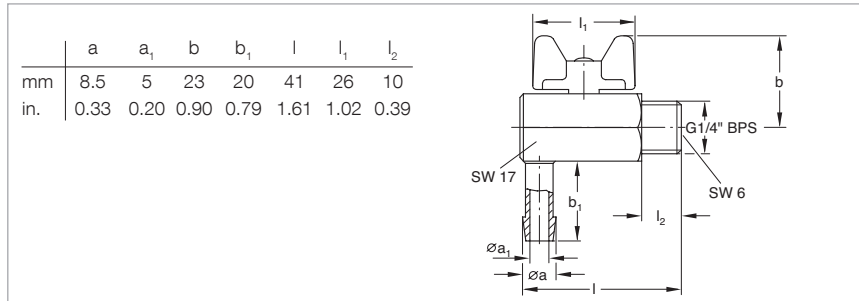

Dimensional drawing for the exhaust filter drain tap

Technical Data

Leak rate	mbar x l/s	$\leq 10^{-5}$
-----------	------------	----------------

Exhaust Filter Drain Tap

Ordering Information

Exhaust Filter Drain Tap

	Part No.
Exhaust filter drain tap	190 95

Oil Drain Tap

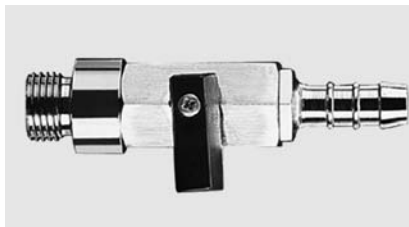

This oil drain tap may be screwed into the oil drain when wanting to change the oil in the rotary vane pumps. It is also suited for the condensate separators and exhaust filters of the TRIVAC B series.

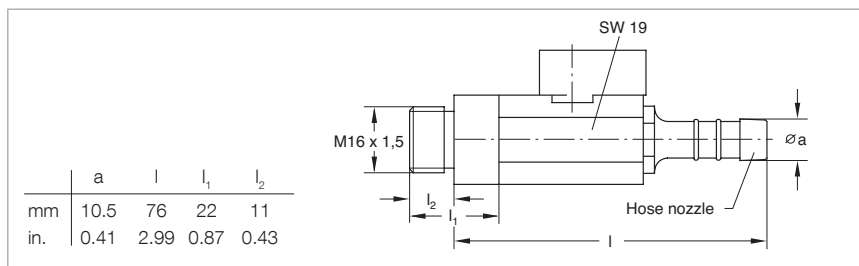

Dimensional drawing for the oil drain tap

Technical Data

Leak rate	mbar x l/s	$\leq 10^{-5}$
-----------	------------	----------------

Oil Drain Tap

Ordering Information

Oil Drain Tap

	Part No.
Oil drain tap	190 90

Oil Drain Kit

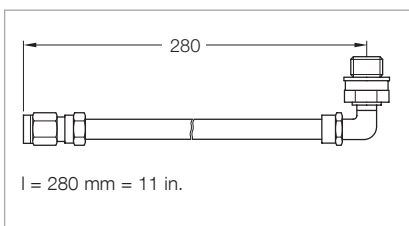

Dimensional drawing for the oil drain kit

Technical Data

Length	mm (in.)	280 (11)
Leak rate	mbar x l/s	$\leq 10^{-5}$

Oil Drain Kit

Ordering Information

Oil Drain Kit

	Part No.
Oil drain kit	190 94

Oil Suction Facility AR-V Controlled by Solenoid Valve

Suited for the AF 8 or AK 8 when connected to the D 2.5 E the oil suction facility AR-V with its solenoid valve allows the removal of oil via the gas ballast which has collected in the exhaust filter. When the valve is closed the gas ballast remains fully operational. For this, a hose link is provided between the exhaust filter and the gas ballast.

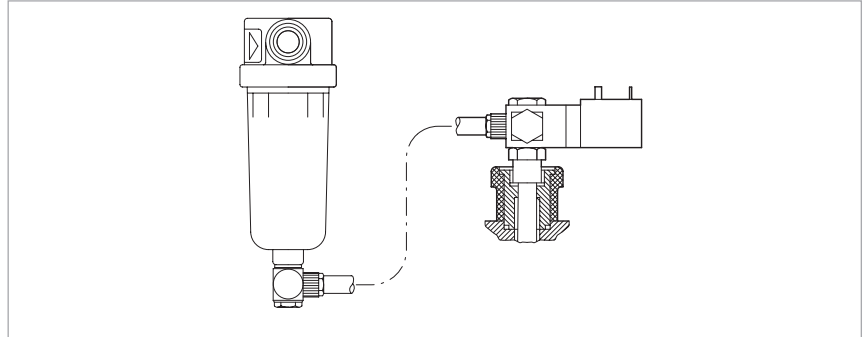

AR-V oil suction facility controlled by solenoid valve (kit without exhaust filter)

Technical Note

If oil which has collected in the exhaust filter is to be removed, the solenoid valve is opened briefly.

Technical Data

AR-V Oil Suction Facility Controlled by Solenoid Valve

Leak rate	mbar x l/s	$\leq 10^{-5}$
-----------	------------	----------------

Ordering Information

AR-V Oil Suction Facility Controlled by Solenoid Valve

	Part No.
AR-V oil suction facility controlled by solenoid valve 24 V DC, 4 W, normally closed	190 92

Manually Operated Oil Suction Facility AR-M

Suited for the AF 8 or AK 8 when connected to the D 2,5 E the oil suction facility AR-M allows the removal of oil via the gas ballast which has collected in the exhaust filter, whereby the gas ballast remains fully operational as long as the angled ball valve remains closed. For this, a hose link is provided between the exhaust filter and the gas ballast.

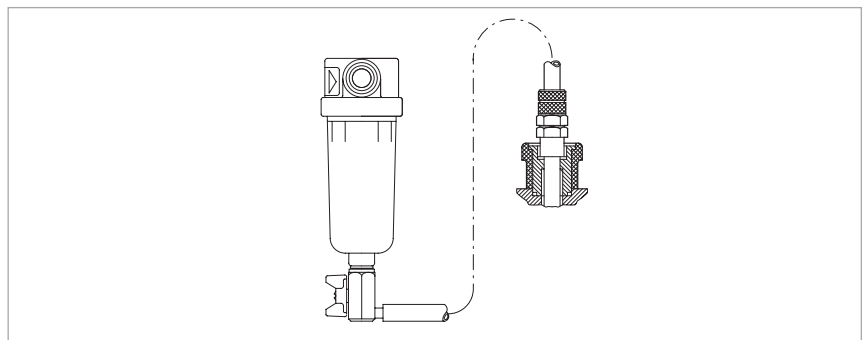

AR-M manually operated oil suction facility (kit without exhaust filter)

Technical Note

If oil which has collected in the exhaust filter is to be removed, the angled ball valve is manually opened briefly.

Technical Data

AR-M Manually Operated Oil Suction Facility

Leak rate	mbar x l/s	$\leq 10^{-5}$
-----------	------------	----------------

Ordering Information

AR-M Manually Operated Oil Suction Facility

	Part No.
AR-M manually operated oil suction facility	190 93

Condensate Separators

AK 4-8 to AK 40-65



AK 4-8 condensate separator

Separators protect the pump against condensate.

Advantages to the User

- May be installed without accessories
- May be used either on the intake or the exhaust side
- Independent of the direction of flow
- Condensate level check via inspection glass
- Resists solvents
- All seals made of FPM (FKM)
- Simple to clean
- Easy to use
- Drained via drain screw or drain tap

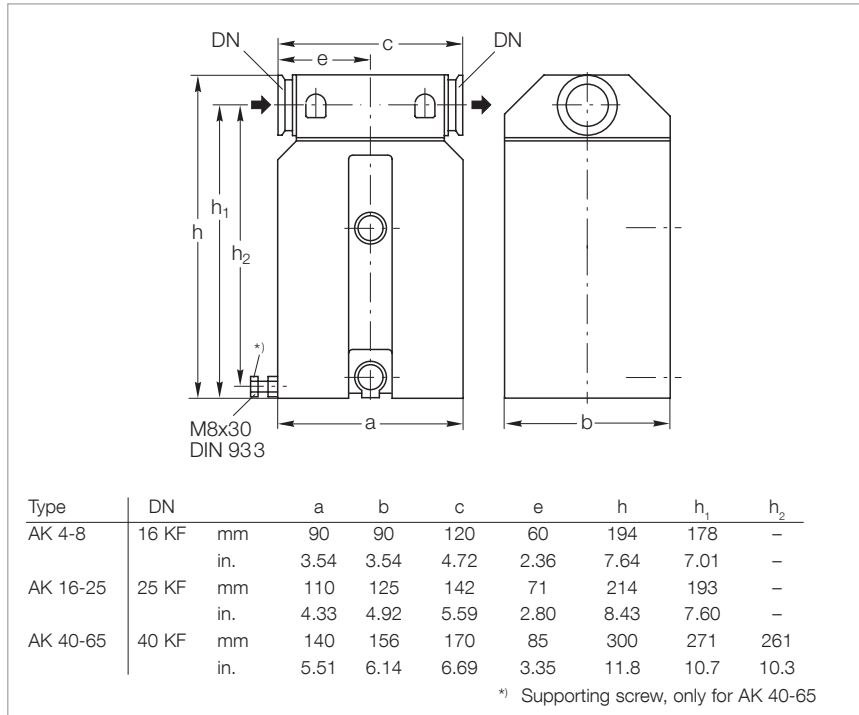

Dimensional drawing for the AK condensate separators

Typical Application

- Prevention of the collection of liquids in the intake line

Technical Information

Depending upon the layout and pipe run of an exhaust line, it may be necessary to install a separator to prevent condensate draining back to the pump.

Technical Data

AK 4-8

AK 16-25

AK 40-65

Connection to pump	TRIVAC	D 4/8 B	D 16/25 B D 16/25 BCS (-PFPE)	D 40/65 B D 40/65 BCS (-PFPE)
Capacity for condensate	l (qt)	0.66 (0.7)	1.2 (1.3)	3.0 (3.2)
Weight	kg (lbs)	1.7 (3.7)	2.4 (5.3)	5.5 (12.1)

Ordering Information

AK 4-8

AK 16-25

AK 40-65

	Part No.	Part No.	Part No.
Condensate separator	188 06	188 11	188 16
Oil drain tap M 16 x 1.5 (vacuum-tight)	190 90	190 90	190 90
Adaptor DN 16 KF – hose nozzle DN 7	182 90	-	-

Dust Filters DN 16 KF to DN 40 KF



Filter housing FH 16 to FH 40 for dust filter insert DF

Dust filters protect the pump against sucked in dust. They are suited for oil sealed and also for dry compressing pumps.

Advantages to the User

- Easy to disassemble
- Vacuum-tight steel housing
- Easily exchangeable replacement filter
- High filter capacity

Technical Information

Installing a dust filter in the intake line of the pump throttles its pumping speed at lower intake pressures much more than at higher intake pressures. Throttling reference values are stated in the Technical Data. These must be taken into account when dimensioning the vacuum system.

Since the collection capacity of dust filters is limited, we recommend the two-stage dust filters AS when larger quantities of dust are involved.

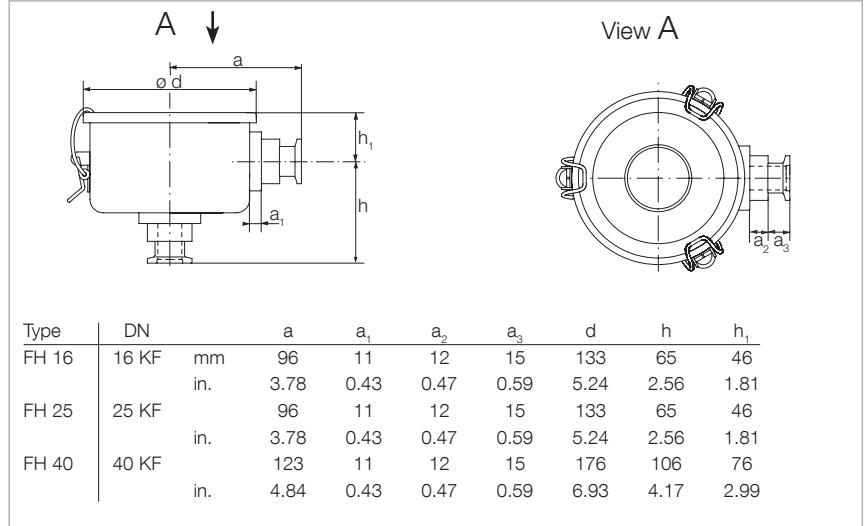

Dimensional drawing for the filter housings FH 16 to FH 40 for dust filter inserts DF

Technical Data

Dust Filter

Use for	TRIVAC	DN 16 KF	DN 25 KF	DN 40 KF
		D 4/8 B	D 16/25 B	D 40/65 B
Share of filtered out particles > 5 µm	%	98	98	98
Throttling of pumping speed at 10 mbar (7.5 Torr)	%	3	3	3
at 1 mbar (0.75 Torr)	%	6	6	6
Weight with dust filter insert	kg (lbs)	1.3 (2.9)	1.3 (2.9)	2.3 (5.1)

Ordering Information

Dust Filter

	DN 16 KF	DN 25 KF	DN 40 KF
	Part No.	Part No.	Part No.
Dust filter filter housing FH ¹⁾	140 116T	140 125T	140 140T
dust filter insert DF 16-25	140 117S	140 117S	-
DF 40-65	-	-	140 141S

¹⁾ The filter housing is supplied without filter cartridge (dust filter insert) since it may also be used in connection with the adsorption trap or dust filter insert

Adsorption Traps DN 16 KF to DN 40 KF



Filter housing FH 16 to FH 40 for adsorption trap filter inserts RF

Adsorption traps are containers with a stainless steel insert which can be filled with a number of different adsorbents thereby offering a high adsorbing capacity for vapors, water vapor in particular.

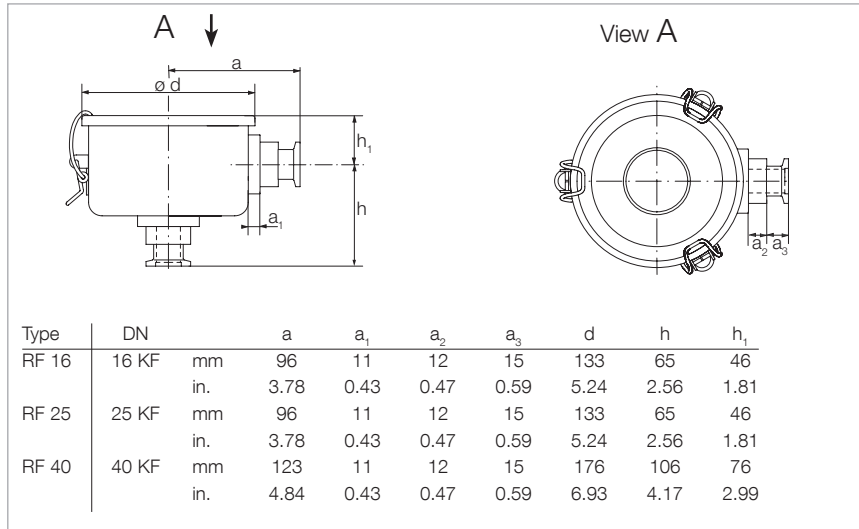

Dimensional drawing for the filter housings FH 16 to FH 40 for adsorption trap filter inserts RF

Advantages to the User

- Vacuum-tight steel housing
- Stainless steel, degassable up to 300 °C (572 °F)
- Different adsorbents and separating elements can be used
- Quick to replace
- Easy to disassemble

Technical Information

The adsorption traps have been developed specially for use in connection with oil sealed pumps. They are capable of retaining oil vapors discharged from forevacuum pumps and are at the same time in the position to separate vapors (water vapor) coming from the side of the process. Through the use of adsorption traps and a suitable adsorbent, a vacuum free of hydrocarbons can be produced. The stainless steel inserts with the corresponding adsorbent can be heated in a drying cabinet at 300 °C (572 °F) for regeneration. Depending on the type of adsorbent and operating pressure, the pumping speed of the pumps is reduced.

As to any questions relating to the selection of a suitable adsorbent, please consult us.

Technical Data

Adsorption Trap

Use for	TRIVAC	DN 16 KF	DN 25 KF	DN 40 KF
		D 4/8 B	D 16/25 B	D 40/65 B
Conductance				
at 10 mbar (7.5 Torr) for				
aluminium oxide	l/s	2	6	14
zeolite	l/s	2	6	12
active charcoal filling	l/s	2	6	16
baffle ring filling	l/s	2	7	18
at 1 mbar (0.75 Torr) for				
aluminium oxide	l/s	1	4	5
zeolite	l/s	1	6	5
active charcoal filling	l/s	2	6	6
baffle ring filling	l/s	2	6	16
Filling quantity				
aluminium oxide	kg (lbs)	0.3 (0.7)	0.3 (0.7)	1.0 (2.2)
zeolite	kg (lbs)	0.2 (0.4)	0.2 (0.4)	0.7 (1.5)
active charcoal filling	kg (lbs)	0.1 (0.2)	0.1 (0.2)	0.5 (1.1)
baffle ring filling	kg (lbs)	0.1 (0.2)	0.1 (0.2)	0.3 (0.7)
Filling volume				
	l (qt)	0.3 (0.3)	0.3 (0.3)	1.2 (1.3)
Weight with adsorption trap insert				
	kg (lbs)	1.3 (2.9)	1.3 (2.9)	2.3 (5.1)

Ordering Information

Adsorption Trap

	DN 16 KF	DN 25 KF	DN 40 KF
	Part No.	Part No.	Part No.
Adsorption trap			
filter housing FH ¹⁾	140 116T	140 125T	140 140T
adsorption trap filter insert			
RF 16-25	140 118A	140 118A	-
RF 40-65	-	-	140 142A
Active charcoal, un-dried, 5 kg	178 10	178 10	178 10
Zeolite, 1 kg	854 20	854 20	854 20
Aluminium oxide, 1.2 kg	854 10	854 10	854 10
Baffle ring 15 x 15 x 0.3, 1 liter			
Stainless steel 1.4301	390 26 126	390 26 126	390 26 126

¹⁾ The filter housing is supplied without filter cartridge (dust filter insert) since it may also be used in connection with the adsorption trap or dust filter insert

Cold Trap TK 4-8



TK 4-8 cold trap

The cold trap protects the pump against damaging vapors.

Advantages to the User

- Rugged and implosion resistant
- May be fitted directly on the flange of the pump
- Safe draining of the condensate without problems
- Casing made of corrosion resistant stainless steel
- Simple filling with refrigerant (liquid nitrogen (LN₂) or a mixture of acetone and carbon di-oxide ice)

Typical Applications

- Prevention of oil from backstreaming into the vacuum system when operating at ultimate pressure
- Freezing of gases and vapors in the laboratory

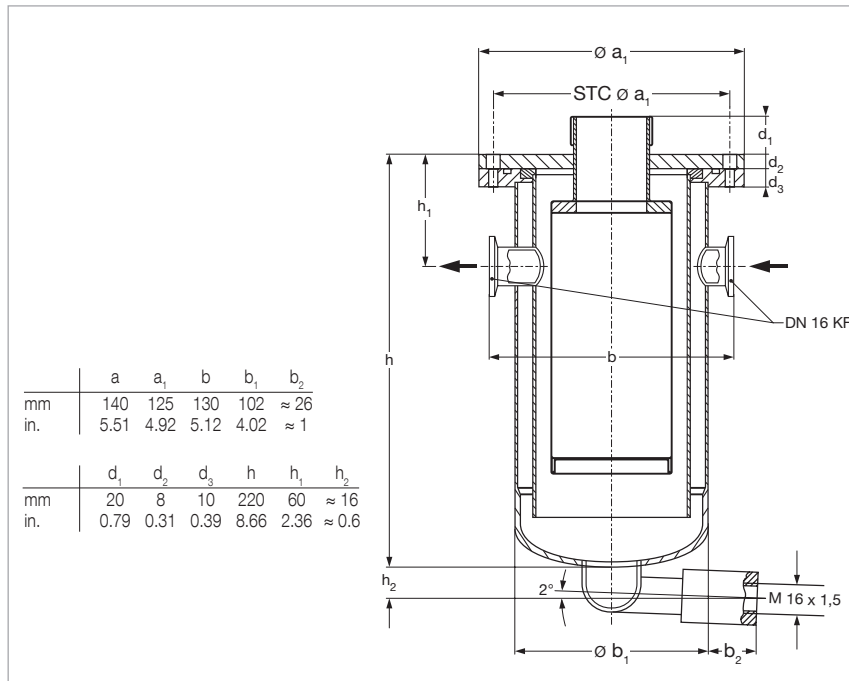

Dimensional drawing for the TK 4-8 cold trap

Technical Data

TK 4-8

Connection to pump	TRIVAC	D 2,5 E / D 4/8 B
Capacity for refrigerant, approx.	l (qt)	0.4 (0.42)
Connections	DN	16 KF
Weight	kg (lbs)	4 (8.8)

Ordering Information

TK 4-8

	Part No.
Cold trap	188 20
Drain tap for the intake side, vacuum-tight	190 90
Elbow (1x)	184 36
Centering ring aluminium/NBR (2x)	183 26
stainless steel/FPM (FKM) (2x)	883 46
Clamping ring (2x)	183 41

Dust Separators AS 8-16 and AS 30-60 / Molecular Filters MF 8-16 and MF 30-60



AS 30-60 dust separator
(MF 30-60 molecular filter is similar)

Dust separators protect pumps against contamination and damage by sucked-in dust.

Advantages to the User

- Dust separators for large quantities of dust
- Two-stage, thus hardly any throttling
- Cyclone (for coarse dust) and wet filter (for fine dust)
- Dust separator and molecular filter have the same housing (for easy conversion)

Typical Application

- Separation of coarse and medium size dust starting at a grain size of 2 μm

Technical Information

Installing a dust filter in the intake line of the pump will throttle its pumping speed at low intake pressures more than at higher intake pressures. This must be taken into account when designing a vacuum system.

Even when large quantities of dust are deposited, the throttling effect will hardly increase.

Supplied Equipment

Blanked off drain port.

Molecular filters are used to separate vapors of a high molecular weight (i.e. monomers, vapors from resins).

Advantages to the User

- Molecular filter and dust separator have the same housing (for easy conversion)
- Separation of high-molecular weight vapors
- Protection of the pump's oil against damaging vapors

Technical Information

Installing a molecular filter in the intake line of the pump will throttle its pumping speed at low intake pressures more than at higher intake pressures. This must be taken into account when designing a vacuum system.

Supplied Equipment

Blanked off drain port.

Technical Data

AS 8-16

AS 30-60

MF 8-16

MF 30-60

Connection to pump	TRIVAC	D 16 B	D 25 B	D 40 B	D 65 B	D 16 B/BCS	D 25 B/BCS	D 40 B/BCS	D 65 B/BCS
Throttling of the pumping speed at 1 mbar (0.75 Torr) intake pressure, approx.	%	10	15	8	16	10	15	8	16
at 10 mbar (7.5 Torr) intake pressure, approx.	%	5	7	4	9	5	7	4	9
Capacity for dust	l (qt)	0.6 (0.63)	0.6 (0.63)	2.0 (2.11)	2.0 (2.11)	–	–	–	–
Capacity for resin vapors or similar	kg (lbs)	–	–	–	–	0.15 (0.3)	0.15 (0.3)	0.35 (0.8)	0.35 (0.8)
Impact ring filling	l (qt)	0.5 (0.53)	0.5 (0.53)	3.5 (3.70)	3.5 (3.70)	–	–	–	–
Active charcoal filling	kg (lbs)	–	–	–	–	0.6 (1.3)	0.6 (1.3)	1.4 (3.1)	1.4 (3.1)
Weight	kg (lbs)	4.5 (9.9)	4.5 (9.9)	18.4 (40.6)	18.4 (40.6)	4.5 (9.9)	4.5 (9.9)	18.4 (40.6)	18.4 (40.6)

Ordering Information

AS 8-16

AS 30-60

MF 8-16

MF 30-60

	Part No.	Part No.	Part No.	Part No.
Dust separator	186 11	186 16	–	–
Molecular filter	–	–	186 12	186 17
Replacement filter insert	–	178 43	–	–
Replacement active charcoal insert	–	–	178 07	178 08
Active charcoal, undried, 5 kg (11 lbs)	–	–	178 10	178 10

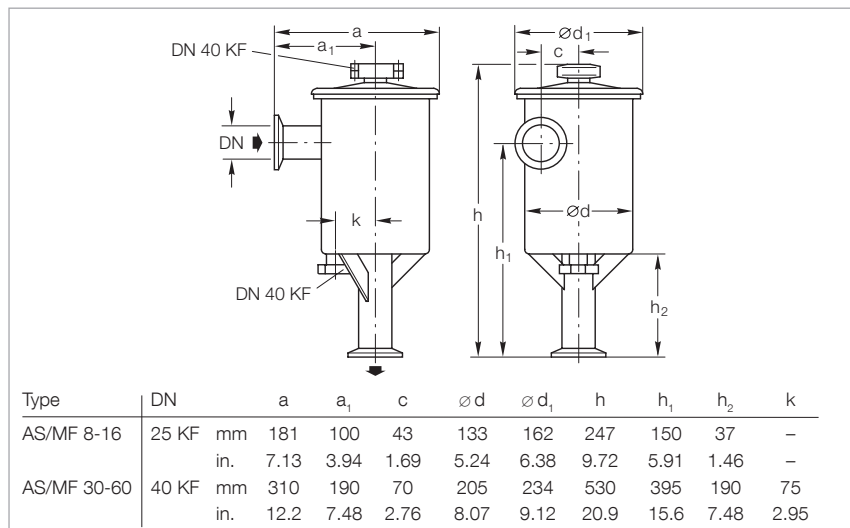

Dimensional drawing for the AS dust separators and MF molecular filters

Mechanical Oil Filters OF 4-25 and OF 40-65 / Chemical Oil Filters CF 4-25 and CF 40-65



OF 4-25 mechanical oil filter

Since there is a pressure-lubrication system with an oil pump in every TRIVAC B, it is possible to connect main flow oil filters.

These filters are available either for mechanical filtering (OF types) or combined chemical/mechanical filtering (CF types).

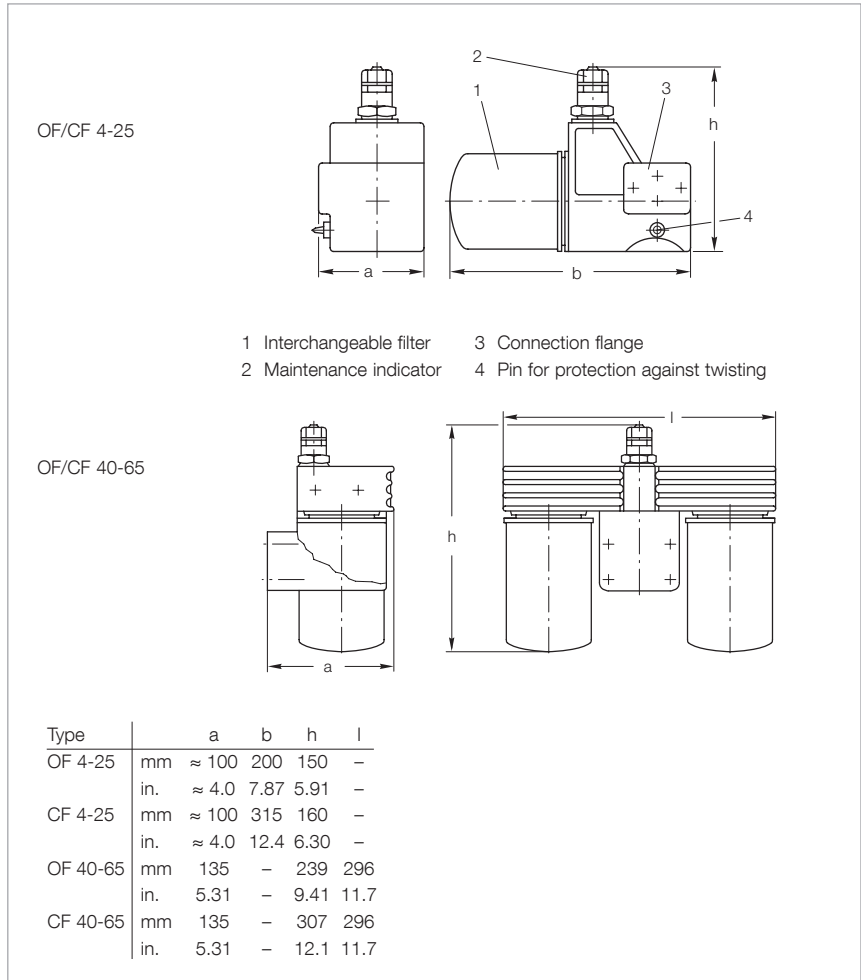

Dimensional drawings for the OF mechanical oil filters and CF chemical oil filters

Advantages to the User

- Main flow oil filter
- Longer service life for the oil depending on the type of application
- Can be installed without problems to the TRIVAC B
- Hose connections are not required
- Easily interchangeable filters
- Only a small amount of oil needs to be added when changing the filters
- Expansion of the range of applications in case of special requirements

Typical Application

- Same casing for OF and CF types
- Greater reliability by standard maintenance indicator
- Built-in bypass valve
- Owing to the highly effective adsorbent for polar substances, an up to ten-fold adsorption effect is attained over normal bleaching earth (CF)
- Prevents mechanical damage to the pump
- Separation of fine particles from the pump's oil (sizes between 5 and 10 µm (OF))

Technical Data**OF 4-25****CF 4-25****OF 40-65****CF 40-65**

Connection to pump	TRIVAC	D 4/8 B, D 16/25 B	D 4/8 B, D 16/25 B	D 40/65 B	D 40/65 B
Nominal throughput	l/h	900	900	2000	2000
Separation					
mechanical oil filter	µm	5 to 10	5 to 10	5 to 10	5 to 10
chemical oil filter	µm	to 3	to 3	to 3	to 3
Permissible operating pressure	bar (psig)	2.5 (21.7)	2.5 (21.7)	2.5 (21.7)	2.5 (21.7)
Opening pressure, non-return valve	bar (psid)	0.12 (1.7)	0.12 (1.7)	0.12 (1.7)	0.12 (1.7)
bypass valve	bar (psid)	2.5 ±0.3 (21.7 ±4.3)	2.5 ±0.3 (21.7 ±4.3)	2.5 ±0.3 (21.7 ±4.3)	2.5 ±0.3 (21.7 ±4.3)
Topping up amount during first time installation	l (qt)	1.0 (1.1)	1.0 (1.1)	2.5 (2.6)	2.5 (2.6)
filter exchange	l (qt)	1.0 (1.1)	1.0 (1.1)	2.0 (2.1)	2.0 (2.1)
Weight, ready for operation, dry	kg (lbs)	4.0 (8.8)	4.0 (8.8)	10.0 (22.1)	10.0 (22.1)

Ordering Information**OF 4-25****CF 4-25****OF 40-65****CF 40-65**

	Part No.	Part No.	Part No.	Part No.
Mechanical oil filter	101 91	-	101 92	-
Chemical oil filter	-	101 96	-	101 97
WF 4-25 interchangeable filter, paper, 0.5 l (0.5 qt)	189 91	-	-	-
WF 40-65 interchangeable filter, paper 0.75 l (0.8 qt)	-	-	189 92 ¹⁾	189 92 ¹⁾
WF Alu 4-65 interchangeable filter, paper and Al ₂ O ₃ , 1 l (1.1 qt)	-	189 96	-	189 96 ¹⁾

¹⁾ 2 pieces are required

Chemical Filters with Safety Isolation Valve

CFS 16-25 and CFS 40-65



CFS 40-65

The CFS chemical filters with safety isolation valve are main flow oil filters for the TRIVAC B and BCS pumps.

The CFS is part of the TRIVAC SYSTEM.

Advantages to the User

- The CFS is included in the main lubricant flow
- Rapid filter exchange
 - the pump may continue to operate while changing the filters
- Visual indication of the filter's condition through a maintenance indicator
- Aluminium component with isolation valve for one or two interchangeable filters
- All aluminium parts are surface protected
- May be operated with different interchangeable filters
- Over-pressure relief valve in the interchangeable filters
- Prepared for connection of a differential pressure switch and an oil pressure switch
- May also be used on the TRIVAC B pumps

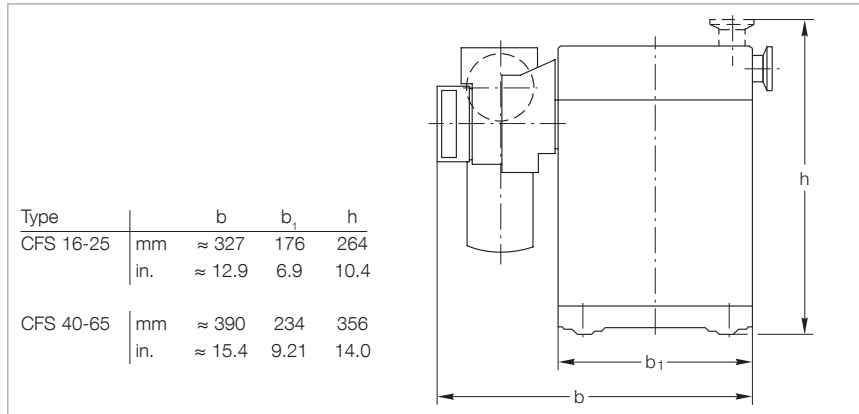

Dimensional drawing for the CFS (mounted on a TRIVAC BCS)

Technical Information

The CFS is cleaned in the factory to such an extent, that it may be operated either with mineral oil (e.g. LEYBONOL LVO 100) or perfluoropolyether (PFPE, e.g. LEYBONOL LVO 400).

Supplied Equipment

All gaskets and mounting parts required for installation.

Aluminium particle filters (WF Alu-Part) sealed for shipping are included separately.

Technical Data

CFS 16-25

CFS 40-65

Connection to pump	TRIVAC	D 16/25 B D 16/25 BCS (-PFPE)	D 40/65 B D 40/65 BCS (-PFPE)
Nominal throughput	l/h	900	2000
Permissible operating pressure	bar (psig)	2.5 (21.7)	2.5 (21.7)
Opening pressure			
Non-return valve	bar (psid)	2.5 (21.7)	2.5 (21.7)
Bypass valve	bar (psid)	2.5 ±0.3 (21.7 ±4.3)	2.5 ±0.3 (21.7 ±4.3)
Filter medium		Al ₂ O ₃	Al ₂ O ₃
Lubricant filling when using WF Alu-Part	l (qt)	1.4 (1.5)	3.3 (3.5)
Weight, ready for operation, dry	kg (lbs)	7.0 (15.4)	15.5 (34.1)

Ordering Information

CFS 16-25

CFS 40-65

	Part No.	Part No.
Chemical filter with safety isolation valve	101 76	101 77
WF Alu-Part combination filter, paper and Al ₂ O ₃ , 1.6 l (1.7 qt)	189 99	189 99 ¹⁾
WFG particle filter, paper with support mesh, 1 l (1.1 qt)	189 90	189 90 ¹⁾

¹⁾ 2 pieces are required

Inert Gas System

IGS 16-25 and IGS 40-65



IGS

This accessory, which is controlled via solenoid valves, permits the controlled admission of special gases into the TRIVAC BCS.

The IGS is part of the TRIVAC SYSTEM.

Advantages to the User

- Ready for connection to an inert gas supply
- Solenoid valve for reduced gas ballast
- Solenoid valve for purging the oil box
- Float throughput gauge with throttling valve adjustable from 200 to 700 l/h
- The flowing quantity can be read directly
- System protection by a non-return valve (requires a reservoir pressure of at least 3 bar (29 psi, gauge)) – this reliably prevents the reservoir vessel from being evacuated
- Connects directly on to the TRIVAC BCS

Typical Applications

- Reduction of the contamination levels in the lubricant
- Reduction in the dwell time of volatile substances within the pump

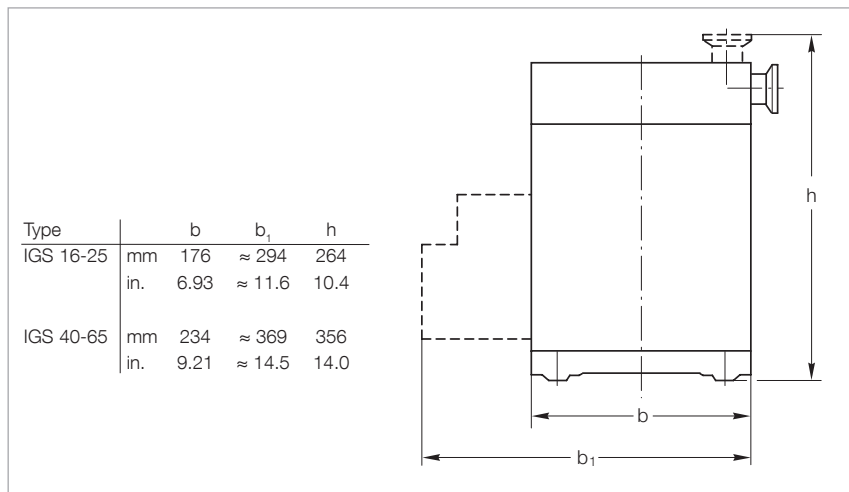

Dimensional drawing for the IGS (mounted on a TRIVAC BCS)

Technical Information

The amount of inert gas ballast is restricted by a nozzle to 200 l/h. Larger quantities are used for purging.

Supplied Equipment

Solenoid valves with connection cables and plugs, the required connecting pieces, mounting screws and cover panel.

Technical Data

	TRIVAC	IGS 16-25	IGS 40-65
Connection to pump	TRIVAC	D 16/25 BCS (-PFPE)	D 40/65 BCS (-PFPE)
Min. amount of admitted gas at a reservoir pressure of 3.0 bar (29 psig)	l/h	200	200
Max. amount of admitted gas at a reservoir pressure of 6.0 bar (72.5 psig)	l/h	1450	1450
Supply voltage for the solenoid valves	V DC	24	24
Power consumption	W	10	10
Weight	kg (lbs)	1.0 (2.2)	1.4 (3.1)
Connection thread	G (BPS)	1/8"	1/8"

Ordering Information

	IGS 16-25	IGS 40-65
Inert gas system	161 76	-
Inert gas system, UL conform	-	161 68V

Limit Switch System

LSS 16-25 and LSS 40-65



LSS

This accessory consists of a package of limit switches. It is used to monitor system functions.

The LSS is part of the TRIVAC SYSTEM.

The package of limit switches includes:

- Differential pressure switch to monitor the CFS
- Oil pressure switch to monitor the operating pressure
- Flow switch to monitor the inert gas flow
- Pressure switch to monitor the pressure in the oil box of the pump
- Connection cable and plug for the temperature switch used for temperature monitoring
- Float switch with housing to monitor the oil level

Advantages to the User

- Errors are indicated well in advance so that it will in most cases be possible to complete the process for the running batch
- The switching action is independent of the optical displays (for optimum reliability)
- The temperature switch is already present in the TRIVAC BCS

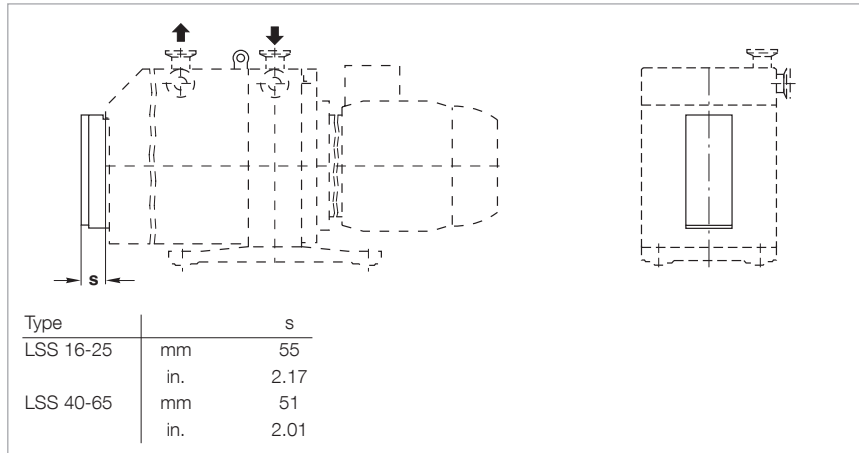

Dimensional drawing for the LSS (mounted on a TRIVAC BCS)

Typical Application

- Changing the status in case operating conditions arise which are not permissible

Supplied Equipment

Fully wired-up switches with plugs as well as all required gaskets and mounting parts.

Technical Data

	TRIVAC	LSS 16-25	LSS 40-65
Connection to pump	TRIVAC	D 16/25 BCS (-PFPE)	D 40/65 BCS (-PFPE)
Operating voltage	V DC	24	24
Switching capacity	W / A	10.0 / 0.4	10.0 / 0.4
Type of protection	IP	54	54
Weight, approx.	kg (lbs)	2.5 (5.5)	2.5 (5.5)

Ordering Information

	LSS 16-25	LSS 40-65
Limit switch system	Part No. 161 06	Part No. 161 07

Roots Pump Adaptor

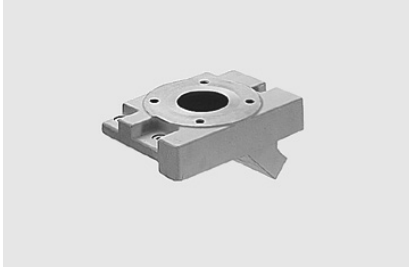

Roots pump adaptor

The Roots pump adaptor allows the direct installation of a Roots pump on a TRIVAC D 40/65 B/BCS.

Advantages to the User

- Compact and space-saving
- Short and direct connection between the pumps
- Minimal conductance loss
- Easy installation

Typical Application

- Simple assembly of a small pump system

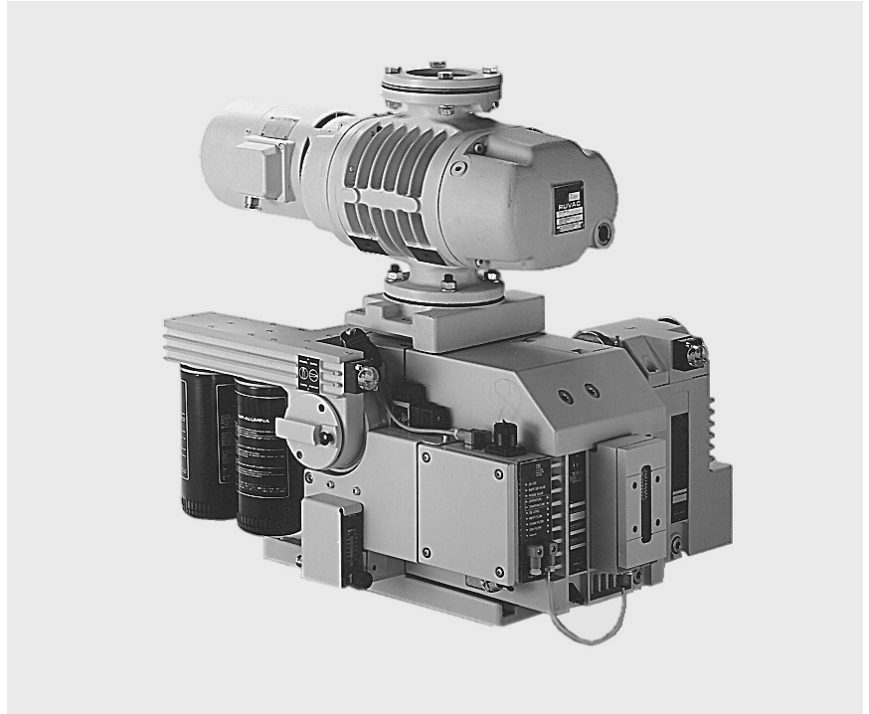

Pump system consisting of a TRIVAC D 65 BCS and a RUVAC WS 251

Technical Data

Connection to pump	TRIVAC	D 40/65 B/BCS (-PFPE) and RUVAC WAWAU/WS/WSU 251
Weight, approx.	kg (lbs)	11.5 (25.4)

Roots Pump Adaptor

Ordering Information

	Part No.
Roots pump adaptor	168 30

Roots Pump Adaptor

Only available for purchase in North and South America

SE Smoke Eliminator



SE smoke eliminator

The Leybold SE smoke eliminator can be utilized on all TRIVAC B rotary vane vacuum pumps where pump fluid loss at the exhaust port must be eliminated. These filters consist of a replaceable two-stage

coalescing element mounted in a steel housing. For maintenance purposes, the top of the housing can be removed by loosening a single bolt. The filter assembly attaches to the exhaust port of the TRIVAC pump by means of a KF flange. Since three models are available, an SE smoke eliminator is available for each TRIVAC pump model.

Advantages to the User

- Two stage design
- Three sizes for all TRIVAC models
- KF flanges

Applications

When any oil sealed mechanical vacuum pump is used to pump a fixed volume from atmospheric pressure to some lower pressure or when a dynamic gas flow from a process stream is pumped, some mechanical pump fluid loss will occur at the exhaust of the pump. The more often a fixed volume is cycled from atmospheric pressure to a lower pressure or the longer a pump operates at a relatively high inlet pressure in a dynamic flow condition, the greater will be the fluid loss at the exhaust port of the pump.

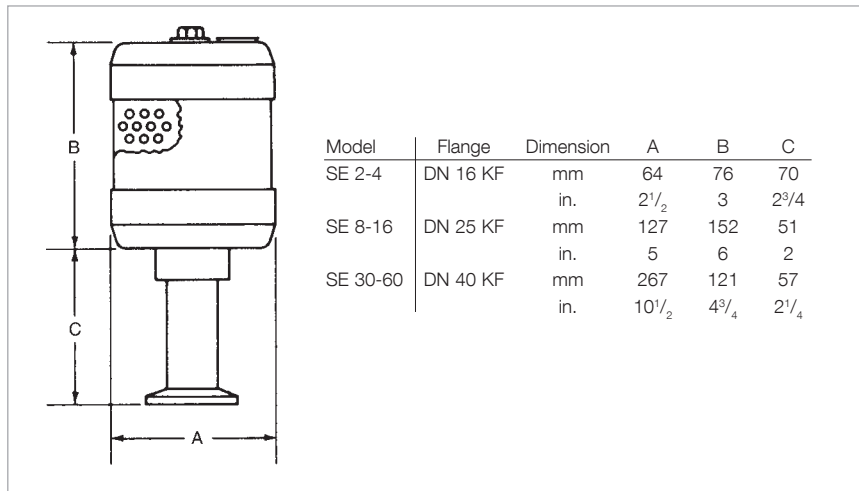

Dimensional drawing for the SE

Technical Data

SE 2-4 SE 8-16 SE 30-60

Connection to pump	TRIVAC	D 4/8 B	D 16/25 B	D 40/65 B
--------------------	--------	---------	-----------	-----------

Ordering Information

SE 2-4 SE 8-16 SE 30-60

	Part No.	Part No.	Part No.
Smoke eliminator	99 171 125	99 171 126	99 171 127
Replacement element			
RE 2-4	99 171 128	-	-
RE 8-16	-	99 171 129	-
RE 30-60	-	-	99 171 130

By utilizing a coalescing exhaust filter for these applications, the fluid and exhaust gases are separated, and in the case of the SE smoke eliminator, the coalesced fluid is allowed to drain back into the pump fluid reservoir. Annoying oil fog to the atmosphere is thus eliminated.

Eventually, after about a year's normal operation, the coalescing element will become totally saturated and oil fog will be apparent when high inlet pressures

are prevailing. The low cost coalescing element can be easily replaced.

Note: For applications where toxic, corrosive, radioactive or precious gases are pumped, we highly recommend the use of our AF coalescing exhaust filters instead of the SE smoke eliminator. The AF is an in-line type coalescing filter and much more suitable for these applications.

General Accessories

Flange Components, Valves

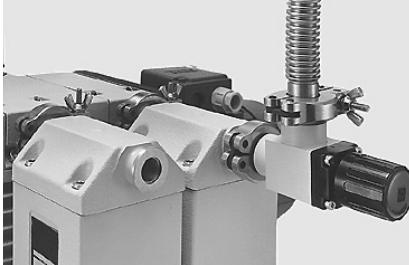

Our range of flange components and valves is described in detail in the Catalog Parts “Flanges and Fittings” and “Valves”.

Given in the following are only some components which you might find particularly useful when planning your system.

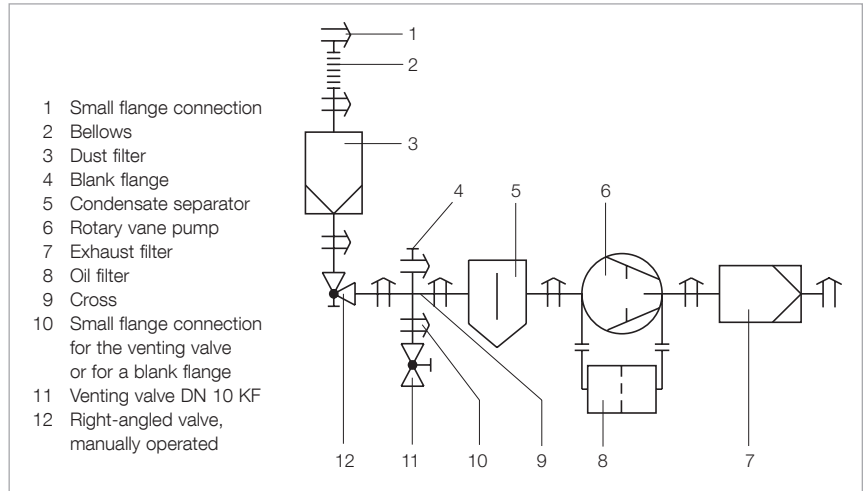

Example of connecting a pump with accessories

Isolation Valve

- The pump is allowed to warm up with the intake line isolated
- The pump may continue to operate in the energy-saving and environmentally compatible ultimate pressure mode when the vacuum chamber is vented briefly
- The pump may be left on after completion of the process so as to regenerate the oil

Branch (Cross)

- Installing a cross in the intake line permits the connection of a vacuum gauge and a venting valve

Flange Connections

Each flange connection requires one each centering and clamping ring.

Ordering Information

DN 16 KF DN 25 KF DN 40 KF

	Part No.	Part No.	Part No.
Small flange connection			
Clamping ring	183 41	183 42	183 43
Centering ring, aluminium/CR	183 26	183 27	183 28
Centering ring, stainless steel/FPM (FKM)	883 46	883 47	883 48
Bellows	872 41	872 43	872 45
Right-angled valve, manually operated			
Aluminium casing	215 375	215 376	215 377
Stainless steel casing	215 383	215 385	215 386
Blank flange for (reducing) cross			
Aluminium	184 46	184 41	184 41
Stainless steel	884 36	884 41	884 41
Reducing cross (to DN 10 KF)			
Aluminium	-	184 17	184 19
Stainless steel	-	884 92	884 94
Cross DN 16 KF			
Aluminium	184 71	-	-
Stainless steel	884 85	-	-
Small flange connection for venting valve or blank flange			
Clamping ring	183 41	183 41	183 41
(Adaptor) centering ring, aluminium/NBR	183 56	183 21	183 21
(Adaptor) centering ring, stainless steel/FPM (FKM)	883 56	883 21	883 21
Venting valve DN 10 KF			
Aluminium	173 24	173 24	173 24
Stainless steel	173 37	173 37	173 37

Miscellaneous

Services

On-site Replacement of the Dynamic Seals (with LEYBONOL LVO 100)

The on-site replacement of the dynamic seals includes the following:

Partial disassembly of the pump, replacement of the complete shaft seal, mounting of the pump including new gaskets and standard oil LEYBONOL LVO 100, electrical safety test, test run including check of the attained ultimate pressure levels.

Ordering Information

On-site Replacement of the Dynamic Seals (with LEYBONOL LVO 100)

	Part No.
For pump	
TRIVAC D 4 B	AS 1130 F
TRIVAC D 8 B	AS 1130 F
TRIVAC D 16/25 B	AS 1129 F
TRIVAC D 40/65 B	AS 1128 F
TRIVAC D 40/65 BCS	AS 1137 F

Small On-site Maintenance (with LEYBONOL LVO 100)

The small on-site maintenance includes the following:

Oil change (standard LEYBONOL LVO 100), filter replacement, visual inspection of the subassemblies, cleaning of the pump module and the oil box, electrical safety test, test run including check of the attained ultimate pressure levels.

Ordering Information

On-site Maintenance (with LEYBONOL LVO 100)

	Part No.
For pump	
TRIVAC D 4 B	AS 1160 F
TRIVAC D 8 B	AS 1159 F
TRIVAC D 16 B + BCS with standard gaskets	AS 1158 F
TRIVAC D 25 B + BCS with standard gaskets	AS 1157 F
TRIVAC D 40/65 B + BCS with standard gaskets	AS 1156 F

Comprehensive On-site Maintenance (with LEYBONOL LVO 100) ¹⁾

Comprehensive on-site maintenance includes the following:

Disassembly of the pump, cleaning of all individual components, replacement of all wearing parts, mounting of the pump including new gaskets and standard oil LEYBONOL LVO 100, electrical safety test, test run including check of the attained ultimate pressure levels.

Ordering Information

Comprehensive On-site Maintenance (with LEYBONOL LVO 100) ¹⁾

	Part No.
For pump	
TRIVAC D 4 B	AS 1125 F
TRIVAC D 8 B	AS 1124 F
TRIVAC D 16 B	AS 1121 F
TRIVAC D 25 B	AS 1120 F
TRIVAC D 40 B	AS 1117 F
TRIVAC D 65 B	AS 1116 F
TRIVAC D 40 BCS with Viton gaskets	AS 1136 F
TRIVAC D 65 BCS with Viton gaskets	AS 1135 F
TRIVAC D 40 BCS with standard gaskets	AS 1132 F
TRIVAC D 65 BCS with standard gaskets	AS 1131 F

¹⁾ Notes on our on-site after sales service

The listed services include the costs for material and working hours on-site for standard TRIVAC pumps. Services for pump variants upon request.

Transportation and travelling expenses are invoiced at cost. All services refer to the repair of freely accessible and not contaminated vacuum components.

As to services for TRIVAC B-DOT, TRIVAC B-Ex and TRIVAC B ³He please ask us for a quotation.

Complete Refurbishing at the Service Center (with LEYBONOL LVO 100)

Complete refurbishing at the service center includes the following:

Disassembly of the pump, visual inspection of the subassemblies, replacement of all wearing parts, machined reworking of the pump module, mounting of the pump including new gaskets and standard oil LEYBONOL LVO 100, electrical safety test, test run including check of the attained ultimate pressure levels.

Ordering Information

**Complete Refurbishing at the Service Center
(with LEYBONOL LVO 100)**

	Part No.
For pump	
TRIVAC D 4 B	AS 1125
TRIVAC D 8 B	AS 1124
TRIVAC D 16 B	AS 1121
TRIVAC D 25 B	AS 1120
TRIVAC D 40 B	AS 1117
TRIVAC D 65 B	AS 1116
TRIVAC D 40 BCS with Viton gaskets	AS 1136
TRIVAC D 65 BCS with Viton gaskets	AS 1135
TRIVAC D 40 BCS with standard gaskets	AS 1132
TRIVAC D 65 BCS with standard gaskets	AS 1131

Complete Refurbishing with Decontamination at the Service Center (with LEYBONOL LVO 100)

Complete refurbishing with decontamination at the service center includes the following:

Disassembly of the pump, decontamination of the individual components, visual inspection of the individual subassemblies, replacement of all wearing parts, machined reworking of the pump module, mounting of the pump including new gaskets and standard oil LEYBONOL LVO 100, electrical safety test, test run including check of the attained ultimate pressure levels.

Ordering Information

**Complete Refurbishing with Decontamination
at the Service Center (with LEYBONOL LVO 100)**

	Part No.
For pump	
TRIVAC D 4 B	AS 1125 D
TRIVAC D 8 B	AS 1124 D
TRIVAC D 16 B	AS 1121 D
TRIVAC D 25 B	AS 1120 D
TRIVAC D 40 B	AS 1117 D
TRIVAC D 65 B	AS 1116 D
TRIVAC D 40 BCS with Viton gaskets	AS 1155 D
TRIVAC D 65 BCS with Viton gaskets	AS 1154 D
TRIVAC D 40 BCS with standard gaskets	AS 1132 D
TRIVAC D 65 BCS with standard gaskets	AS 1131 D

Only available for purchase in North and South America

60 Hz Curves

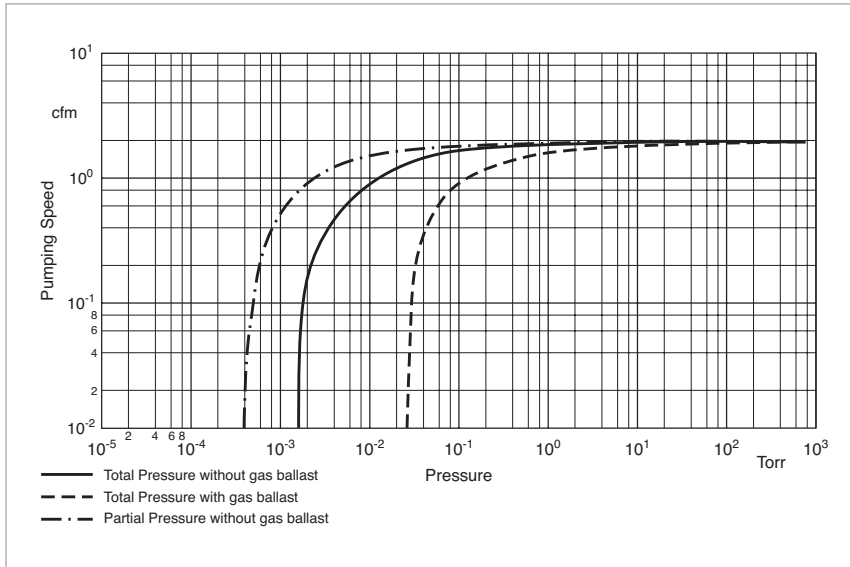

Pumping speed characteristics for the TRIVAC D 2,5 E at 60 Hz

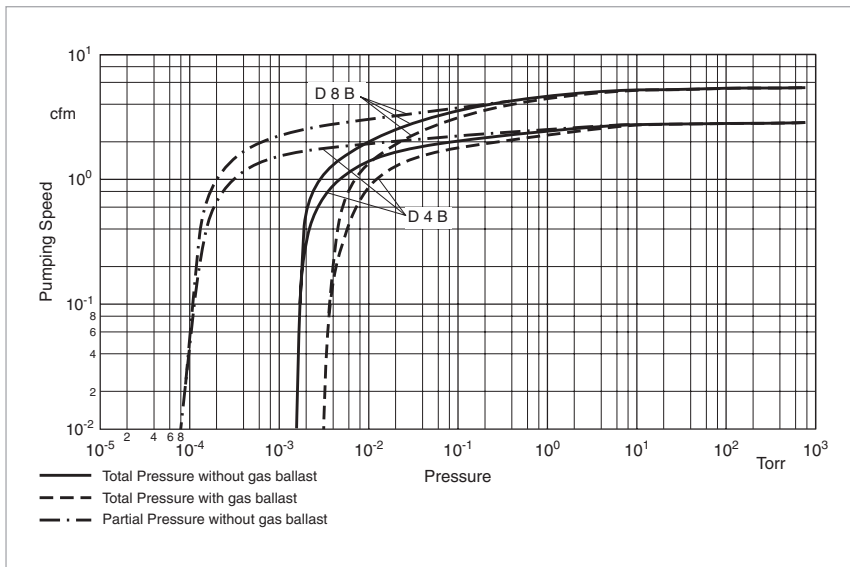

Pumping speed characteristics for the TRIVAC D 4 B and D 8 B at 60 Hz

Only available for purchase in North and South America

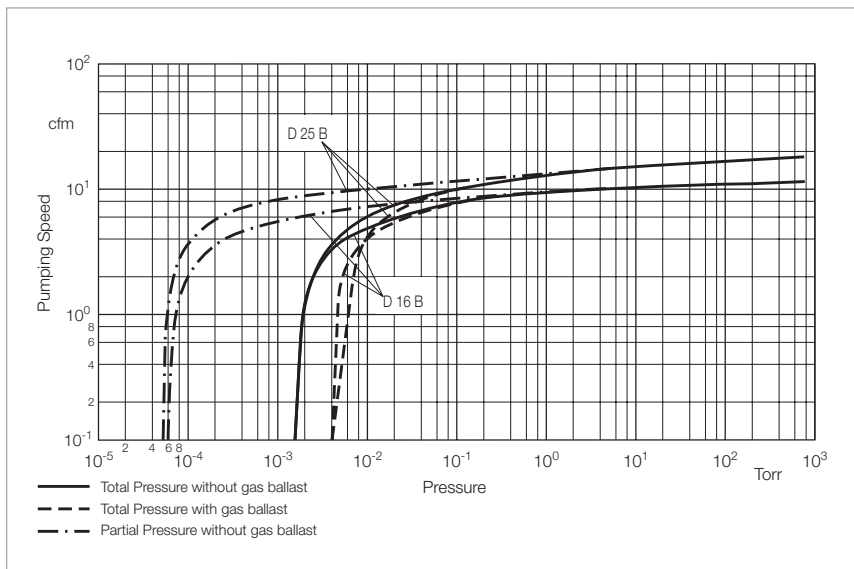

Pumping speed characteristics for the TRIVAC D 16 B/BCS and D 25 B/BCS at 60 Hz

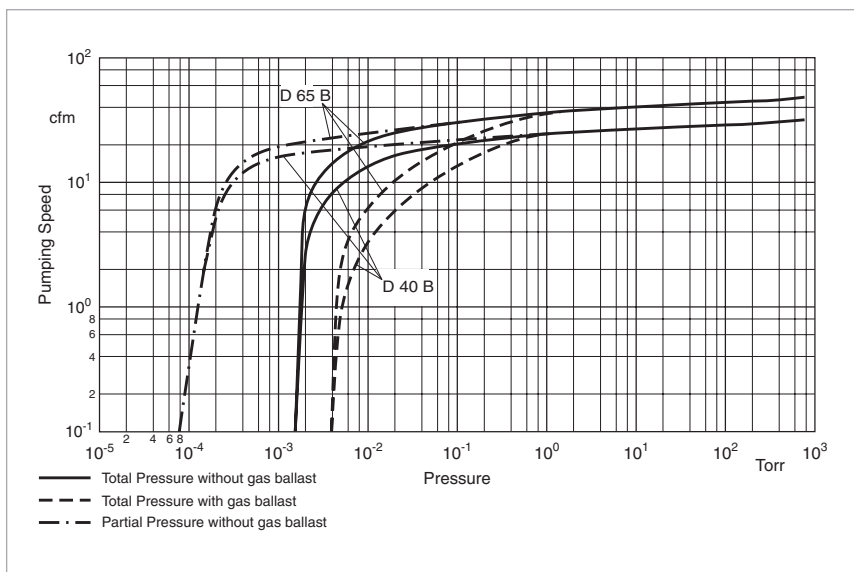

Pumping speed characteristics for the TRIVAC D 40 B/BCS and D 65 B/BCS at 60 Hz

Applications for SOGEVAC pumps

Applications	Pumps																				
	SOGEVAC SV 10 B	SOGEVAC SV 16 B	SOGEVAC SV 25 B	SOGEVAC SV 16 D	SOGEVAC SV 25 D	SOGEVAC SV 40 B	SOGEVAC SV 65 B	SOGEVAC SV 100 B	SOGEVAC SV 120 B	SOGEVAC SV 200	SOGEVAC SV 300 B	SOGEVAC SV 470/570 B	SOGEVAC SV 470/570 BF	SOGEVAC SV 630 B	SOGEVAC SV 630 BF	SOGEVAC SV 750 B/BF	SOGEVAC SV 1200	SOGEVAC SV 28 Bf	SOGEVAC SV 40 Bf	SOGEVAC SV 40 ATEX	
Vacuum coating						■	■	■	■	■	■	■	■	■							
Research and development				■	■														■	■	
Chemistry/pharmaceuticals			■			■	■	■	■	■											■
Metallurgy/furnaces						■	■	■	■	■	■	■	■	■	■					■	
Lamps and tubes manufacture	■	■	■	■	■	■	■	■											■	■	
Automotive industry	■	■	■	■	■	■	■	■	■	■	■	■	■	■	■						■
Laser engineering	■	■		■	■																
Space simulation								■		■	■	■	■	■	■	■	■	■	■		
Analytical engineering				■	■														■	■	
Environment engineering				■	■	■	■	■	■	■	■										■
Cooling and air-conditioning	■	■	■	■															■	■	
Electrical engineering				■		■	■	■	■	■	■	■	■	■	■						
Mechanical engineering				■		■	■	■	■	■	■	■	■	■	■	■					■
Medicine technology		■	■	■	■	■	■	■	■	■									■	■	
Freeze drying systems				■		■	■	■	■	■	■	■	■	■	■				■	■	
Backing pump for high vacuum pump systems	■	■	■	■		■	■												■	■	
Food industry	■	■	■	■		■	■	■	■	■	■		■		■						
Plant engineering	■	■	■	■	■	■	■	■	■	■	■	■	■	■	■	■	■	■	■	■	
Power engineering/district heating				■		■	■	■	■	■											
Cleaning									■	■	■	■	■	■	■						
Packaging	■	■	■	■		■	■	■	■	■	■	■	■	■	■						

Oil for SOGEVAC pumps for different fields of application

Applications	Vacuum coating	Research and development	Chemistry/Pharmaceutical	Metallurgy/Furnaces	Lamps and tubes manufactures	Automotive industry	Laser technology	Space technology	Analytical simulation	Environment engineering	Electrical technologies	Mechanical engineering	Medicine technology	Vacuum technology	Backing drying cabinets	Food industry	Plant engineering for HV pump systems	Power engineering	Cleaning	Packaging
LEYBONOL Oils																				
LVO 120	■	■	■	■	■		■	■	■	■	■	■	■	■	■	■	■	■	■	■
LVO 130	■	■	■	■	■		■	■		■	■	■	■	■	■	■	■	■	■	■
LVO 140											■	■			■					■
LVO 150											■	■			■					■
LVO 200	■	■	■	■	■		■		■	■							■	■		
LVO 210	■	■	■	■	■		■				■						■	■		
LVO 300				■					■	■	■	■	■	■		■			■	
LVO 400	■	■	■								■			●	■					■
DOT 4						■														

- = Standard
- = Possible

The table only lists general applications. Your specific requirements might be subject to deeper analysis. For further questions, please contact our technical Sales support.

For information on oil specifications please refer to Catalog Part "Oils / Greases / Lubricants LEYBONOL®".

Oil for SOGEVAC pumps for different pump types

Pumps	Pump line			D			A			B / BF			BI		ATEX
	SV 16 D, SV 25 D	SV 40, SV 65	SV 100	SV 200, SV 300	SV 500, SV 630, SV 750	SV 1200	SV 10 B, SV 16 B/FP	SV 25 B/FP	SV 40 B, SV 45 FP	SV 65 B, SV 100 B, SV 120 B/FP	SV 28 BI, SV 40 BI	SV 40 B Category 1 (I)/2(o)	SV 40 B Category 1 (I)/2(o)	SV 40 B to 630 B Category 3 (I)/3(o)	
LEYBONOL Oils															
LVO 120	■	■					■	■	▲ ¹⁾			■			
LVO 130	▲	▲	■	■	■	■			▲ ²⁾	■	■				
LVO 140	●	●	●				●	●	▲	▲					
LVO 150			●	●	●	●		▲	●	●	●				
LVO 200	●	●	●				●	●	▲	▲		●	■		▲
LVO 210	▲ ²⁾	▲ ²⁾	●	●	●	●	▲	▲	●	●	●			■	■
LVO 300	●	●	●	●	▲	▲			●	●	▲				▲
LVO 400	●	●	●	●	●	●				●	●				● ³⁾
LVO 420															
DOT 4		●							●						

- = Standard
- = Possible
- ▲ = Please contact Leybold Valence

¹⁾ = with single-phase motor

²⁾ = with three-phase motor

³⁾ = ATEX outside only

The table only lists general applications. Your specific requirements might be subject to deeper analysis. For further questions, please contact our technical Sales support.

For information on oil specifications please refer to Catalog Part "Oils / Greases / Lubricants LEYBONOL®".

Product Range, Features and Design

Oil sealed rotary vane vacuum pumps are being used in all areas of vacuum engineering. They are equally suited for both industrial production and research applications. They may be used to generate a rough and medium vacuum or as backing pumps in pump combinations with Roots vacuum pumps or high vacuum pumps. The SOGEVAC pumps excel also to their low noise levels and smooth operation.

Many years of experience in vacuum engineering and the latest developments in pump technology combine in the SOGEVAC range the capability to adapt to the requirements of both the industry and the environment. The comprehensive range (pumping speeds ranging from 10 to 1200 m³ x h⁻¹ (5.9 to 707 cfm)) allows every customer to select the right pump for his particular needs.

Application Examples

- Automotive industry
- Food industry
- Furnaces and plants
- Vacuum coating
- Metallurgy
- Power engineering, long-distance energy
- Space simulation
- Laser technology
- Medicinal technology

Advantages to the User

- Continuous operation from atmospheric pressure to ultimate pressure
- High pumping speed also at low pressures
- Low noise level
- Low vibrations
- Integrated exhaust filter, better than 99.9% efficient
- No oil loss owing to the integrated oil return line
- Exhaust gas free of oil mists
- Efficient air cooling (standard)
- Water cooling (optional)
- Low space requirement, easy to install
- Rugged
- Maintenance-friendly
- Compact design
- For direct fitting to Roots pumps from SV 100 B up
- Optimum size-to-performance ratio
- High water vapor tolerance
- For use in various applications
- Wide range of accessories available for adaptation to differing problems

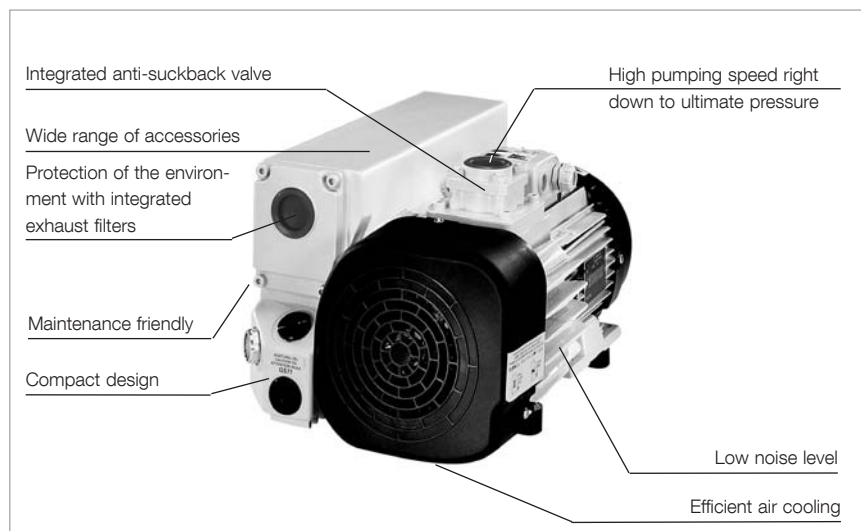

Outstanding features of the SOGEVAC pumps

Design Principle

SOGEVAC pumps are oil sealed rotary vane pumps. Oil injected into the pump chamber for sealing, lubrication and cooling of the pump is recycled from the pump's oil reservoir and filtered, if required, before it is injected. The lubricant system is rated for continuous operation at high intake pressures (max. 1000 mbar abs.) so that the pumps may be used in a versatile manner in most rough vacuum applications (accessories are required for some pumps).

The oil carried with the process gas is roughly separated in the oil box before the discharged gas enters the integrated exhaust filters where the fine oil mist is trapped. The thus filtered oil is collected in the oil box and then supplied back to the pump.

The separating system optimized in consideration of all operating conditions for the vacuum pump guarantees – also at high intake pressures and when pumping out of vapors – an exhaust gas which is free of oil mist (separation efficiency over 99.9%).

Materials used:

Steel, Cast iron, Aluminium, Bronze, FPM (FKM), Glass, Polyamid 6.6, Filter material (Polymers, Paper), Epoxy resin & Glass fibre.

Leybold rotary vane vacuum pumps from the SOGEVAC series excel through numerous special features:

Compact Design

The pumps have been so designed that efficiency of the pumps will be high.

For the SV 10 B through SV 65 B, the motor and pumping section use the same shaft. For the SV 100 B to SV 1200 the motor is linked depending on requirements to the pumping section directly via a coupling or via V-belts as a pedestal motor. All vacuum components like anti-suckback, exhaust filter with oil return line needed for a complete vacuum unit as well as the optimized placement of all controls and monitoring components allow for an extremely compact unit.

Quiet Operation

SOGEVAC pumps are designed throughout to keep the noise level as low as possible. This is ensured by optimized running and sliding speeds and the selection of low-noise drive motors, as well as perfected manufacturing techniques using CNC automatic machines for optimized tolerances and reproducibility of the individual components.

Anti-Suckback Valve

A valve is built into the intake of the SOGEVAC pumps. This “anti-suckback valve” is protected by a metal wire-mesh filter. During standstill of the pump (for example due to shutting down or a power failure) the valve closes the intake. This prevents the pressure from rising in the connected chamber while the pump is vented at the same time. Any suck-back of pump oil into the vacuum system is thus also effectively prevented. This blocking process operates under all operating conditions (below 800 mbar (600 Torr)) and even when the gas ballast valve is open.

Protection of the Environment

The built-in exhaust filter ensures an oil-mist free exhaust gases over the entire range of operating pressures – from atmospheric pressure to ultimate pressure.

Supplied Equipment

All pumps are delivered with the required quantity of oil: SV 10 B to SV 65 B in a separate canister, whereas the SV 100 B and larger pumps already contain the oil and are thus ready for operation.

PFPE variants are typically delivered without fluid LVO 400.

Products

SOGEVAC SV 10 B / SV 16 B

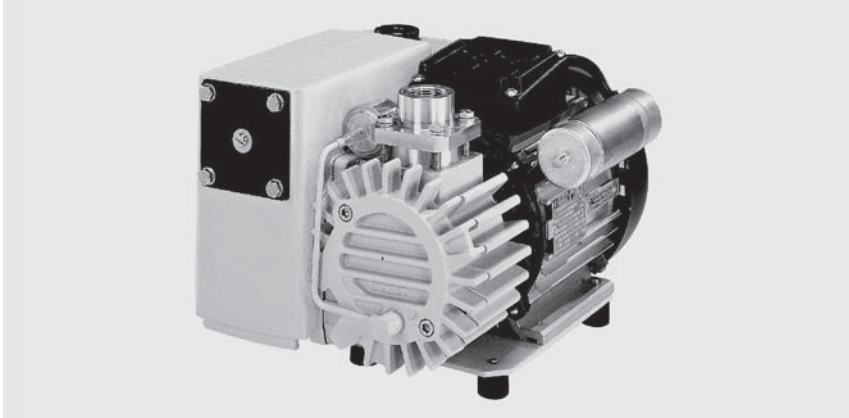

SOGEVAC SV 16 B

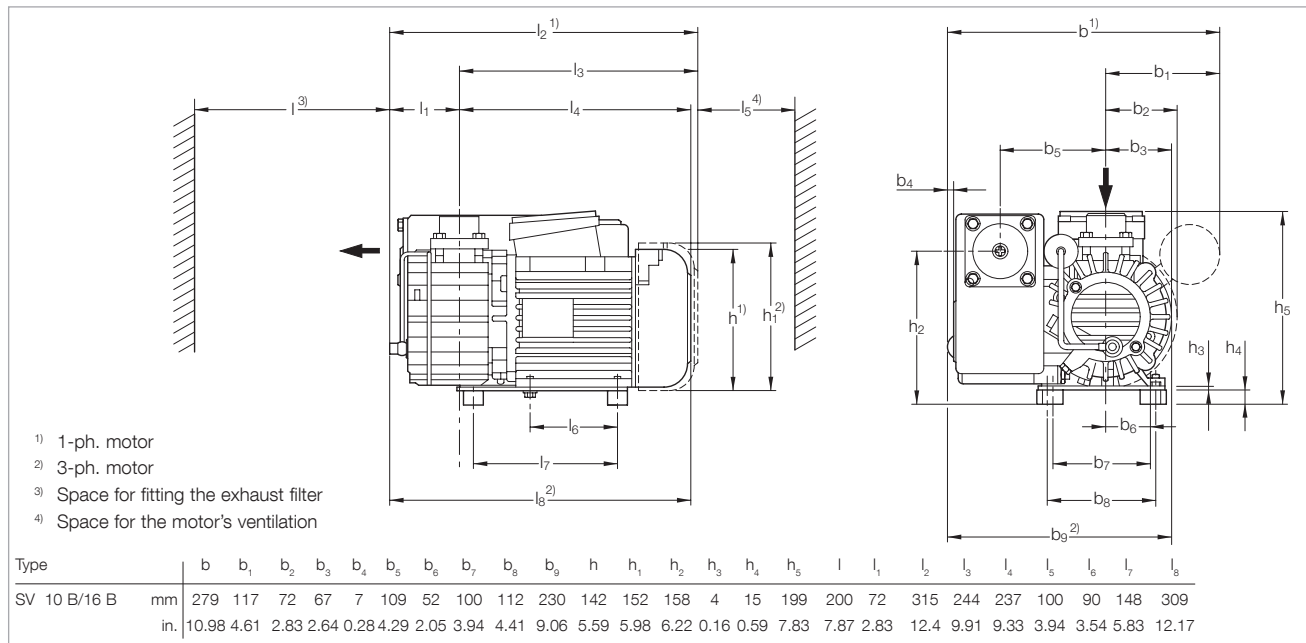

Dimensional drawing for the SOGEVAC SV 10 B and SV 16 B

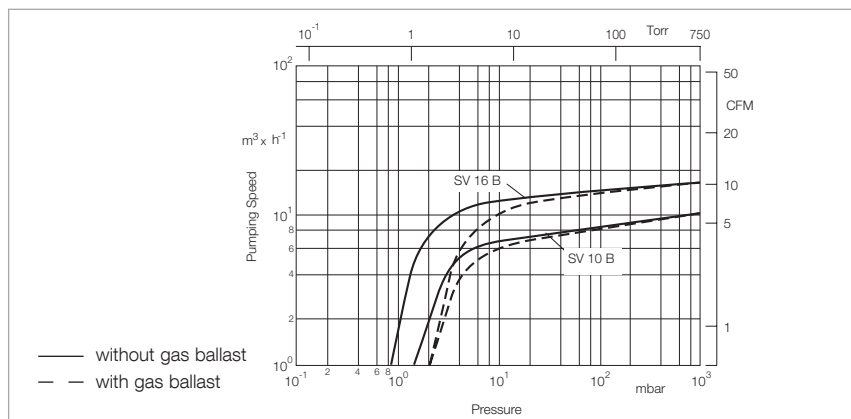

Pumping speed characteristics of the SOGEVAC SV 10 B and SV 16 B at 50 Hz (60 Hz curves at the end of the chapter)

Technical Data

SOGEVAC SV 10 B

SOGEVAC SV 16 B

		50 Hz	60 Hz	50 Hz	60 Hz
Nominal speed ¹⁾	m ³ /h (cfm)	11.0 (6.5)	13.0 (7.7)	16.0 (9.4)	19.0 (11.2)
Pumping speed ¹⁾	m ³ /h (cfm)	9.5 (5.6)	11.5 (6.8)	15.0 (8.8)	17.0 (10.0)
Ultimate total pressure without gas ballast ¹⁾	mbar (Torr)	≤ 1.5 (≤ 1.1)	≤ 1.5 (≤ 1.1)	≤ 1.0 (≤ 0.8)	≤ 1.0 (≤ 0.8)
Ultimate total pressure with gas ballast ¹⁾	mbar (Torr)	≤ 2.5 (≤ 1.9)	≤ 2.5 (≤ 1.9)	≤ 2.0 (≤ 1.5)	≤ 2.0 (≤ 1.5)
Water vapor tolerance ¹⁾	mbar (Torr)	10.0 (7.5)	15.0 (11.3)	10.0 (7.5)	15.0 (11.3)
Water vapor capacity	g/h (qt/hr)	20 (0.02)	30 (0.03)	30 (0.03)	50 (0.05)
Oil capacity	l (qt)	0.5 (0.53)	0.5 (0.53)	0.5 (0.53)	0.5 (0.53)
Noise level ²⁾	dB(A)	62 (1-ph.) - 60 (3-ph.)	66 (1-ph.) - 64 (3-ph.)	62 (1-ph.) - 60 (3-ph.)	66 (1-ph.) - 64 (3-ph.)
Admissible ambient temperature	°C (°F)	12 to 40 (54 to 104)	12 to 40 (54 to 104)	12 to 40 (54 to 104)	12 to 40 (54 to 104)
Motor power	kW (hp)	0.55 (0.75)	0.75 (1.02)	0.55 (0.75)	0.75 (1.02)
Nominal speed	min ⁻¹ (rpm)	3000 (3000)	3600 (3600)	3000 (3000)	3600 (3600)
Type of protection	IP	55-F	55-F	55-F	55-F
Weight (with oil filling)	kg (lbs)	20.0 (41.55)	20.0 (41.55)	20.5 (45.25)	20.5 (45.25)
Dimensions (L x W x H)	mm (in.)	315 x 281 x 199 (12.4 x 11.06 x 7.83)	315 x 281 x 199 (12.4 x 11.06 x 7.83)	315 x 281 x 199 (12.4 x 11.06 x 7.83)	315 x 281 x 199 (12.4 x 11.06 x 7.83)
Connections intake (Inside thread) ³⁾	G	3/4" + 1/2"	3/4" + 1/2"	3/4" + 1/2"	3/4" + 1/2"

Ordering Information

SOGEVAC SV 10 B

SOGEVAC SV 16 B

	50/60 Hz	50/60 Hz
	Part No.	Part No.
SOGEVAC SV 10 B/SV 16 B with three-phase motor, with gas ballast 220-240/380-415 V, 50 Hz and 220-266/380-460 V, 60 Hz (CEI)	960 100	960 160
200 V, 50/60 Hz	960 115	960 175
with single-phase motor ⁴⁾ , with gas ballast 230 V, 50/60 Hz (CEI)	960 105	960 165
110-120 V, 60 Hz	960 110	960 170
100 V, 50/60 Hz	960 114	960 174
Other voltages/frequencies ⁵⁾	upon request	upon request
Filling with special oil	upon request	upon request
Accessories		
Exhaust filter cartridge AFE SV10B/16B	714 13 280	714 13 280
Exhaust connection G 3/4"	971 433 140	971 433 140
Spare Parts		
Repair kit	714 22 230	714 22 230
Maintenance kit	971 444 430	971 444 430
Seal kit FPM (FKM)	714 22 220	714 22 220

¹⁾ To DIN 28 400 and following numbers

²⁾ Operated at the ultimate pressure without gas ballast, free-field measurement at a distance of 1 m (3.5 ft)

³⁾ 1/2" adapter supplied. Basic port is 3/4"

⁴⁾ Single-phase motors do not have plugs, cords or ON/OFF switches

⁵⁾ Please indicate when ordering a pump

Materials (materials in contact with the gas) Steel cast iron, Aluminium, Bronze, FPM (FKM), Glass, Polyamid 6.6, Filter material, (Polymers, Paper) Epoxy resin & Glass fibre

Remark: The SV 10 B and SV 16 B cannot work continuously above 150 mbar. Please consult Leybold for this application

SOGEVAC SV 16 D and SV 25 D



SOGEVAC SV 16 D / 25 D

Advantages to the User

- Good pump temperature due to optimized air cooling. Add water cooling possible, ideal for harsh applications and optimal oil life time thus reached
- 4 times more oil than on comparable pumps allow long oil life times
- Optimized integrated lubrication without external pipes
- Integrated oil recovery system and anti suckback valve
- Low noise level due to low pump speed
- Variant concept
- 3 phase wide range motors
- Different single phase motors with overload protection in accordance to EN 61010-1
- Compact and nice design

Typical Applications

- Oil purification, drying and de-gassing
- Plastic and rubber injection presses
- CO₂ lasers
- O₂ applications
- Analytical Instruments
- ... and more

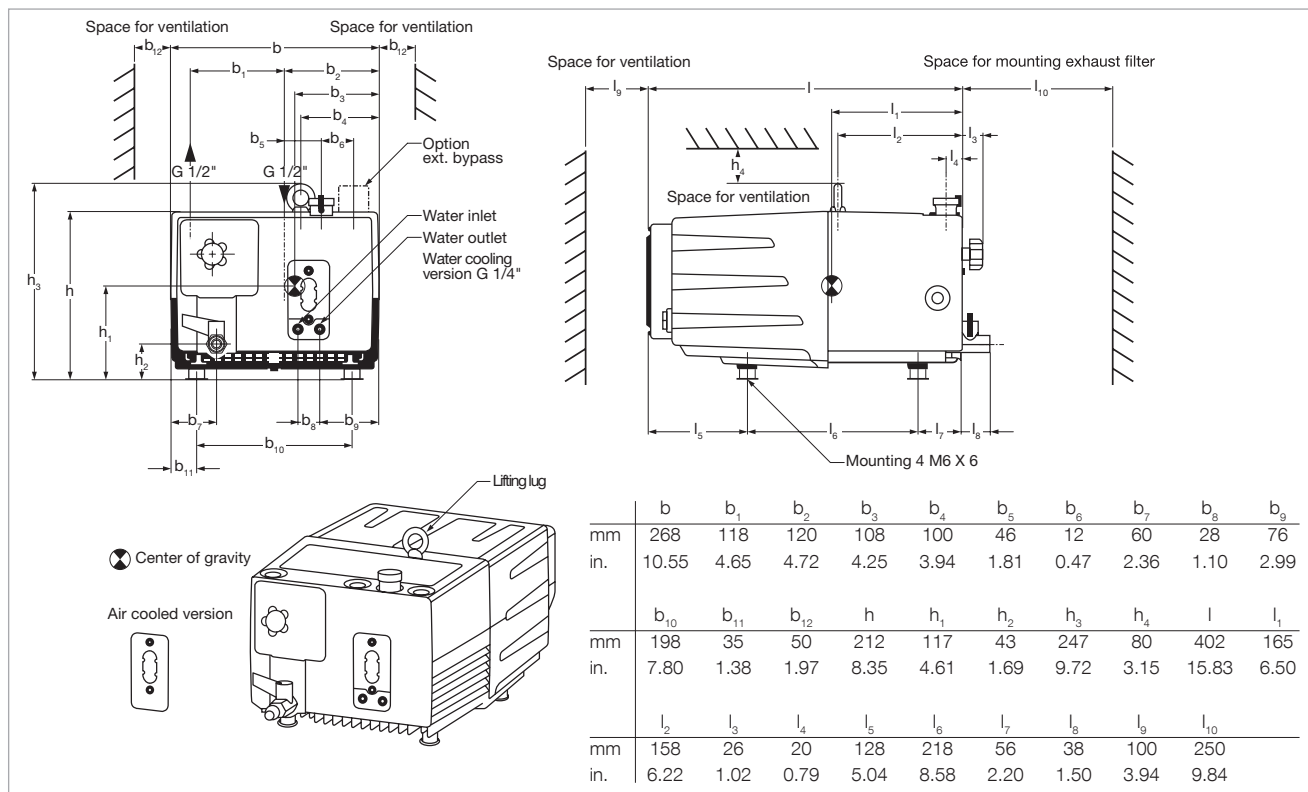

Dimensional drawing for the SOGEVAC SV 16 D and SV 25 D

Technical Data

		SOGEVAC SV 16 D		SOGEVAC SV 25 D	
		50 Hz	60 Hz	50 Hz	60 Hz
Nominal speed ¹⁾	m ³ /h (cfm)	16.0 (9.4)	18.7 (11.0)	25.0 (14.7)	29.0 (17.0)
Pumping speed ¹⁾	m ³ /h (cfm)	14.5 (8.5)	17.0 (10.0)	22.5 (13.3)	25.5 (15.0)
Ultimate total pressure without gas ballast ¹⁾	mbar (Torr)	≤ 0.5 (≤ 0.4)	≤ 0.5 (≤ 0.4)	≤ 0.5 (≤ 0.4)	≤ 0.5 (≤ 0.4)
Ultimate total pressure without gas ballast ¹⁾	mbar (Torr)	≤ 1.5 (≤ 1.1)	≤ 1.5 (≤ 1.1)	≤ 1.5 (≤ 1.1)	≤ 1.5 (≤ 1.1)
Water vapor tolerance ¹⁾	mbar (Torr)	15.0 (11.3)	15.0 (11.3)	15.0 (11.3)	15.0 (11.3)
Water vapor capacity	kg/h (qt/hr)	0.05 (0.05)	0.15 (0.16)	0.05 (0.05)	0.15 (0.16)
Oil capacity	l (qt)	2.0 (2.1)	2.0 (2.1)	2.0 (2.1)	2.0 (2.1)
Noise level ²⁾	dB(A)	59	59	59	59
Admissible ambient temperatur					
1~ (oil: 32 cSt, approx.)	°C	+18 to +40	+18 to +40	+18 to +40	+18 to +40
	(°F)	(+64 to 104)	(+64 to 104)	(+64 to 104)	(+64 to 104)
3~	°C	+12 to +40	+12 to +40	+12 to +40	+12 to +40
	(°F)	(+54 to 104)	(+54 to 104)	(+54 to 104)	(+54 to 104)
Motor power (1~ and 3~), approx.	kW (hp)	0.75 (1.01)	0.90 (1.21)	0.75 (1.01)	0.90 (1.21)
Nominal speed	min ⁻¹ (rpm)	1440 (1440)	1750 (1750)	1440 (1440)	1750 (1750)
Weight (with oil filling)	kg (lbs)	25 (55.1)	25 (55.1)	25 (55.1)	25 (55.1)
Connections, Intake and Exhaust ³⁾ (Inside thread)	NPT/G	1/2"	1/2"	1/2"	1/2"

¹⁾ To DIN 28 400 ff

²⁾ Operated at the ultimate pressure without gas ballast, free-field measurement at a distance of 1 m (3.5 ft)

³⁾ Please indicate when ordering a pump

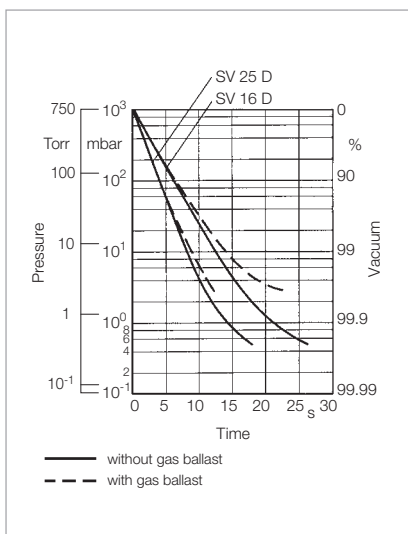

Pump-down characteristics of a 10 l vessel at 50 Hz

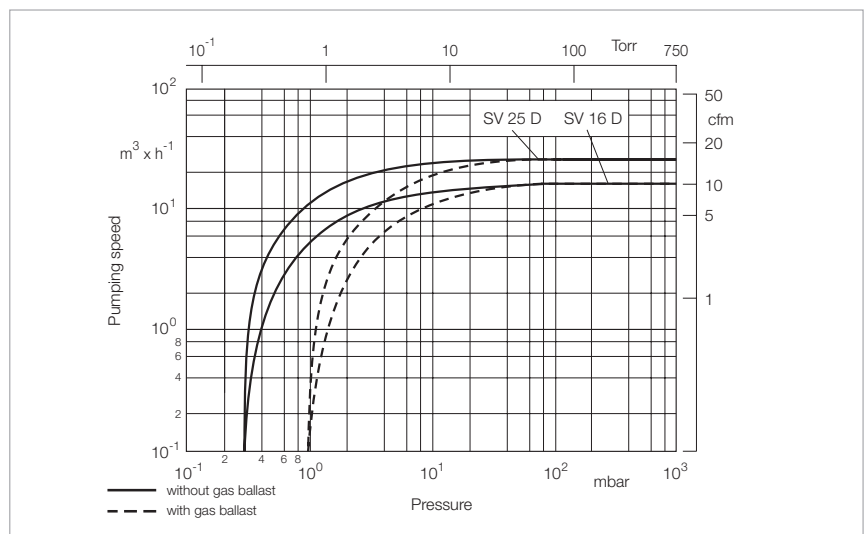

Pumping speed characteristics of the SOGEVAC SV 16 D and SV 25 D at 50 Hz (60 Hz curves at the end of the chapter)

Ordering Information

SOGEVAC SV 16 D

SOGEVAC SV 25 D

	Part No.	Part No.
SOGEVAC SV 16/SV 25 D with UL/CSA world three-phase motor and integrated gas ballast valve 200 - 240 V ±10% and 380 - 415 V ±10%, 50 Hz / 200 - 240 V ±10% and 380 - 460 V ±10%, 60 Hz ¹⁾ 200 V +10-15%, 50/60 Hz	960 181V	960 211V
	960 180V	960 210V
with single phase motor and integrated gas ballast valve 200 - 240 V ±10%, 50/60 Hz	960 185V	—
230 V ±10%, 50/60 Hz	—	960 215V
110 - 115 V ±10% and 220 - 230 V ±10%, 50/60 Hz (switchable manually)	960 186V	—
Other voltages/frequencies	upon request	upon request
Filling with special oil	upon request	upon request
Accessories		
Exhaust filter monitoring gauge, mechanical G 3/4" ^{2), 3)}	951 93	951 93
Temperature switch conversion kit with plug, for three-phase version only ^{2), 3)}	upon request	upon request
Spare Parts		
Exhaust filter cartridge AFE SV16/25 BR2	712 32 023	712 32 023
Maintenance kit (filter, O-Ring, filling plug)	EK 971 473 420	EK 971 473 420
Seal kit FPM (FKM)	EK 971 473 430	EK 971 473 430
Repair kit complete	EK 971 473 440	EK 971 473 440

¹⁾ Pumps are delivered in high voltage connection.

For an operation at low voltage, the connections at motor terminal board must be changed

²⁾ Please indicate when ordering a pump

³⁾ Can be retrofitted

SOGEVAC SV 25 B

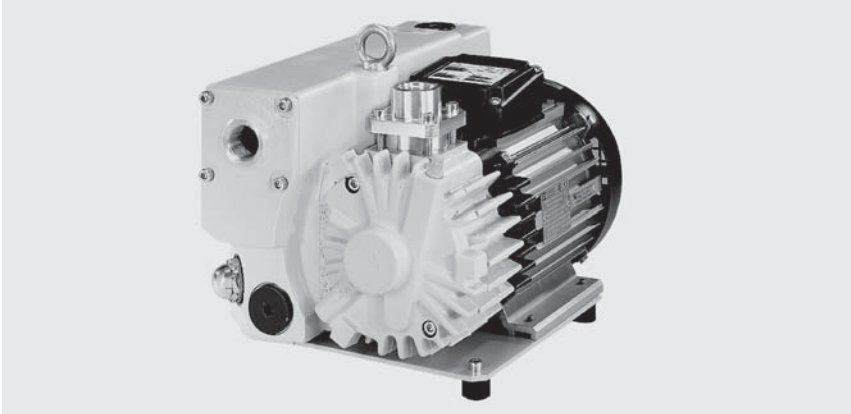

SOGEVAC SV 25 B

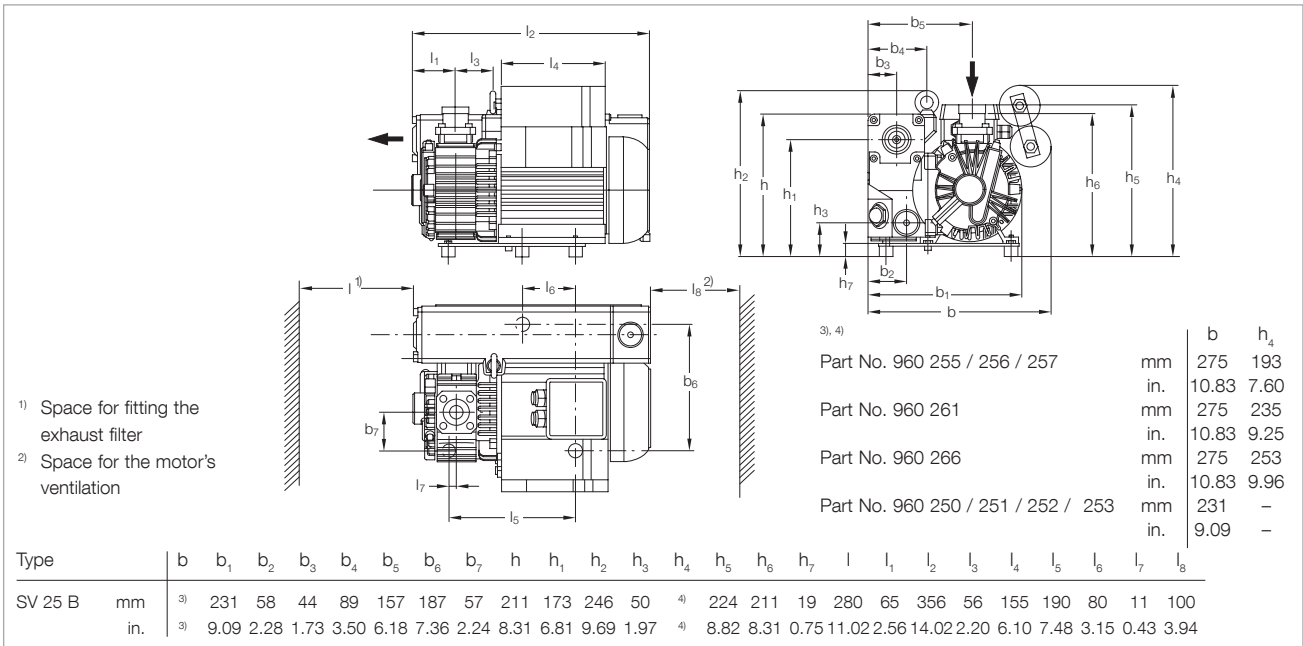

Dimensional drawing for the SOGEVAC SV 25 B

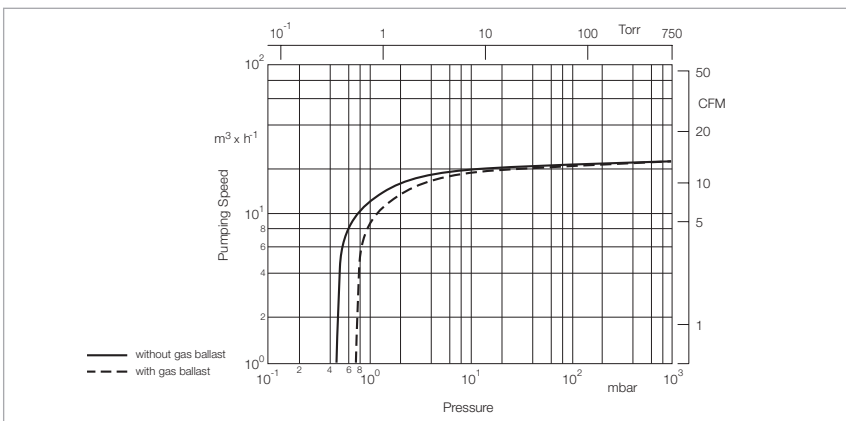

Pumping speed characteristics of the SOGEVAC SV 25 B at 50 Hz
(60 Hz curves at the end of the chapter)

Technical Data

SOGEVAC SV 25 B

50 Hz

60 Hz

		50 Hz	60 Hz
Nominal speed ¹⁾	m ³ /h (cfm)	26.0 (15.3)	31.0 (18.3)
Pumping speed ¹⁾	m ³ /h (cfm)	22.5 (13.3)	25.0 (14.7)
Ultimate total pressure without gas ballast ¹⁾	mbar (Torr)	≤ 0.5 (≤ 0.4)	≤ 0.5 (≤ 0.4)
Ultimate total pressure with gas ballast ¹⁾	mbar (Torr)	≤ 0.8 (≤ 0.6)	≤ 0.8 (≤ 0.6)
Water vapor tolerance ¹⁾	mbar (Torr)	10.0 (7.5)	10.0 (7.5)
Water vapor capacity	g/h (qt/hr)	85 (0.09)	100 (0.11)
Oil capacity	l (qt)	0.5 (0.53)	0.5 (0.53)
Noise level ²⁾	dB(A)	64	67
Admissible ambient temperature	°C (°F)	12 to 40 (54 to 104)	12 to 40 (54 to 104)
Motor power	kW (hp)	0.9 (1.2)	1.1 (1.5)
Nominal speed	min ⁻¹ (rpm)	3000 (3000)	3600 (3600)
Type of protection	IP	55-F	55-F
Weight (with oil filling)	kg (lbs)	26 (57.4) [three-phase] 27 (60.0) [single-phase]	26 (57.4) [three-phase] 27 (60.0) [single-phase]
Dimensions (L x W x H)	mm (in.)	356 x 275 x 246 (14.02 x 10.83 x 9.69)	356 x 275 x 246 (14.02 x 10.83 x 9.69)
Connections ³⁾			
Intake ⁴⁾	G or NPT	3/4" + 1/2"	3/4" + 1/2"
Exhaust	G or NPT	3/4"	3/4"

Ordering Information

SOGEVAC SV 25 B 50/60 Hz

	Part No.
SOGEVAC SV 25 B with three-phase motor, without gas ballast 200-240/346-415 V, 50 Hz and 200-277/346-480 V, 60 Hz (CEI)	960 250
200-240/346-415 V, 50 Hz and 200-277/346-480 V, 60 Hz (CEI), NPT flanges	960 252
with three-phase motor, with gas ballast 200-240/346-415 V, 50 Hz and 200-277/346-480 V, 60 Hz (CEI)	960 251
200-240/346-415 V, 50 Hz and 200-277/346-480 V, 60 Hz (CEI), NPT flanges	960 253
with single-phase motor, without gas ballast 230 V, 50/60 Hz (CEI)	960 255
with single-phase motor, with gas ballast 230 V, 50/60 Hz (CEI)	960 256
230 V, 50/60 Hz, NPT flanges (CEI)	960 257
110-120 V, 60 Hz	upon request
100 V, 50/60 Hz	upon request
Other voltages/frequencies ⁵⁾	upon request
Filling with special oil ⁵⁾	upon request
Accessories	
Exhaust filter cartridge AFE SV25B	714 16 340
Spare Parts	
Maintenance kit	971 423 450
Repair kit	971 423 100
Seal kit FPM (FKM)	714 19 490

¹⁾ To DIN 28 400 and following numbers

²⁾ Operated at the ultimate pressure without gas ballast, free-field measurement at a distance of 1 m (3.5 ft)

³⁾ Pumps with European and Japanese motors have G,
pumps with NEMA motors have NPT

⁴⁾ 1/2" adapter supplied. Basic port is 3/4"

⁵⁾ Please indicate when ordering a pump

Materials (materials in contact with the gas) Steel cast iron, Aluminium, Bronze, FPM (FKM), Glass, Polyamid 6.6, Filter material, (Polymers, Paper) Epoxy resin & Glass fibre

SOGEVAC SV 40 B / SV 65 B



SOGEVAC SV 65 B

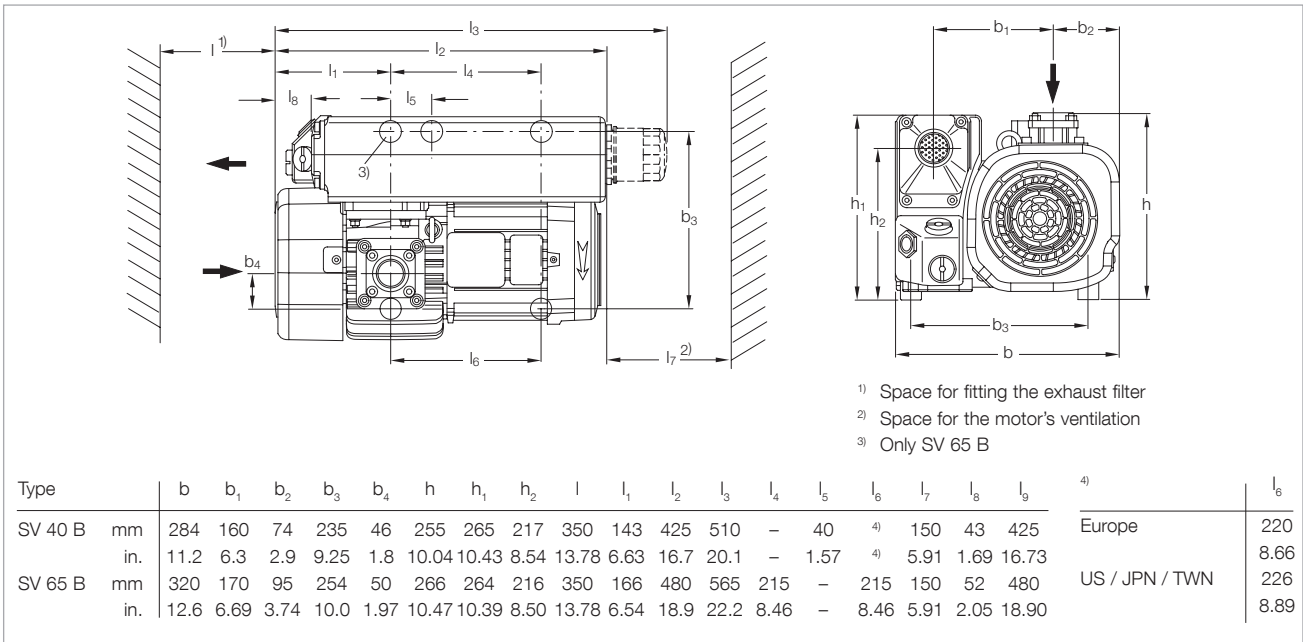

Dimensional drawing for the SOGEVAC SV 40 B and SV 65 B with standard motor, European version

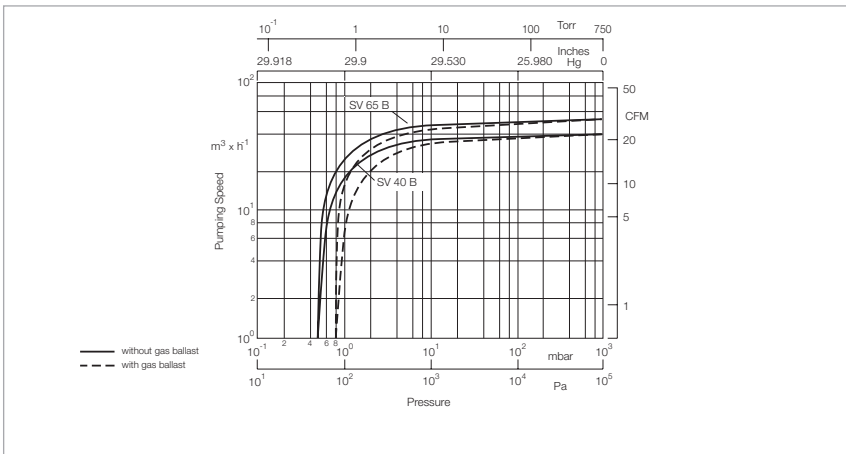

Pumping speed characteristics of the SOGEVAC SV 40 B and SV 65 B at 50 Hz (60 Hz curves at the end of the chapter)

Technical Data		SOGEVAC SV 40 B		SOGEVAC SV 65 B	
		50 Hz	60 Hz	50 Hz	60 Hz
Nominal speed ¹⁾	m ³ /h (cfm)	44.0 (25.9)	53.0 (31.2)	59.0 (34.8)	71.0 (41.8)
Pumping speed ¹⁾	m ³ /h (cfm)	38.5 (22.7)	47.0 (27.7)	54.0 (31.8)	64.0 (37.7)
Ultimate total pressure without gas ballast ¹⁾	mbar (Torr)	≤ 0.5 (≤ 0.4)	≤ 0.5 (≤ 0.4)	≤ 0.5 (≤ 0.4)	≤ 0.5 (≤ 0.4)
Ultimate total pressure ¹⁾					
with standard gas ballast ²⁾	mbar (Torr)	≤ 1.5 (≤ 1.1)	≤ 1.5 (≤ 1.1)	≤ 1.5 (≤ 1.1)	≤ 1.5 (≤ 1.1)
with small gas ballast ²⁾	mbar (Torr)	≤ 0.8 (≤ 0.6)	≤ 0.8 (≤ 0.6)	≤ 0.8 (≤ 0.6)	≤ 0.8 (≤ 0.6)
Water vapor tolerance ¹⁾					
with standard gas ballast ²⁾	mbar (Torr)	30.0 (22.5)	30.0 (22.5)	30.0 (22.5)	30.0 (22.5)
with small gas ballast ²⁾	mbar (Torr)	10.0 (7.5)	10.0 (7.5)	10.0 (7.5)	10.0 (7.5)
Water vapor capacity					
with standard gas ballast ²⁾	kg/h (qt/hr)	0.76 (0.80)	0.90 (0.95)	1.0 (1.1)	1.25 (1.32)
with small gas ballast ²⁾	kg/h (qt/hr)	0.28 (0.30)	0.34 (0.36)	0.36 (0.38)	0.42 (0.44)
Oil capacity	l (qt)	1.0 (1.05)	1.0 (1.05)	2.0 (2.1)	2.0 (2.1)
Mean noise level ³⁾	dB(A)	58	60	60	64
Admissible ambient temperature	°C (°F)	12 to 40 (54 to 104)	12 to 40 (54 to 104)	12 to 40 (54 to 104)	12 to 40 (54 to 104)
Motor power	kW (hp)	1.1 (2.0)	1.5 (2.0)	1.5 (3.0)	1.8 (3.0)
Nominal speed	min ⁻¹ (rpm)	1500 (1500)	1800 (1800)	1500 (1500)	1800 (1800)
Type of protection	IP	55-F	55-F	55-F	55-F
Weight (with oil filling)	kg (lbs)	43 (94.9)	45 (99.3)	49 (108.2)	52 (114.8)
Dimensions (L x W x H)	mm (in.)	425 x 284 x 265 (16.7 x 11.2 x 10.4)	425 x 284 x 265 (16.7 x 11.2 x 10.4)	480 x 320 x 265 (18.9 x 12.6 x 10.4)	480 x 320 x 265 (18.9 x 12.6 x 10.4)
Connection (inside thread) ⁴⁾					
Intake	G or NPT	1 1/4"	1 1/4"	1 1/4"	1 1/4"
Exhaust	G or NPT	1 1/4"	1 1/4"	1 1/4"	1 1/4"

¹⁾ To DIN 28 400 and following numbers

²⁾ Ordering Information, see next page

³⁾ Operated at the ultimate pressure without gas ballast, free-field measurement at a distance of 1 m (3.5 ft)

⁴⁾ Pumps with European and Japanese motors have G, pumps with US motors have NPT

Materials (materials in contact with the gas) Steel cast iron, Aluminium, Bronze, FPM (FKM), Glass, Polyamid 6.6, Filter material, (Polymers, Paper) Epoxy resin & Glass fibre

Ordering Information

SOGEVAC SV 40 B

SOGEVAC SV 65 B

	50/60 Hz	50/60 Hz
	Part No.	Part No.
SOGEVAC SV 40 B, SV 65 B ¹⁾		
with three-phase motor, without gas ballast, without oil filter 230/400 V, 50 Hz and 460 V, 60 Hz (CEI)	960 300	960 400
wide range motor (CEI) ²⁾	960 320 ²⁾	960 420 ²⁾
with three-phase motor, without gas ballast, with oil filter 230/400 V, 50 Hz and 460 V, 60 Hz (CEI)	960 302	960 402
with three-phase motor, with small gas ballast, without oil filter 230/400 V, 50 Hz and 460 V, 60 Hz (CEI)	960 301	960 401
230/460 V, 60 Hz and 400 V, 50 Hz, NPT flanges (UL/CSA motor) ³⁾	960 311	960 411
wide range motor (CEI) ²⁾	960 321 ²⁾	960 421 ²⁾
200 V, 50/60 Hz	960 316	960 416
with three-phase motor, with small gas ballast, with oil filter 230/400 V, 50 Hz and 460 V, 60 Hz (CEI)	960 303	960 403
230/460 V, 60 Hz and 400 V, 50 Hz, NPT flanges (UL/CSA motor) ³⁾	960 313	960 413
wide range motor (CEI) ²⁾	960 323 ²⁾	960 423 ²⁾
200 V, 50/60 Hz	960 318	960 418
with three-phase motor, with standard gas ballast, without oil filter 230/400 V, 50 Hz and 460 V, 60 Hz (CEI)	960 305	960 405
230/460 V, 60 Hz and 400 V, 50 Hz, NPT flanges (UL/CSA motor) ³⁾	960 312	960 412
wide range motor (CEI) ²⁾	960 322 ²⁾	960 422 ²⁾
200 V, 50/60 Hz	960 317	960 417
with three-phase motor, with standard gas ballast, with oil filter 230/400 V, 50 Hz and 460 V, 60 Hz (CEI)	960 307	960 407
230/460 V, 60 Hz and 400 V, 50 Hz, NPT flanges (UL/CSA motor) ³⁾	960 314	960 414
wide range motor (CEI) ²⁾	960 324 ²⁾	960 424 ²⁾
200 V, 50/60 Hz	960 319	960 419
Other voltages/frequencies ⁴⁾	upon request	upon request
Filling with special oil ⁴⁾	upon request	upon request
Accessories		
Exhaust filter cartridge		
AFE SV40B	714 21 180	-
AFE SV65/100B	-	714 17 300
Spare Parts		
Maintenance kit	971 427 660	971 423 440
Repair kit	971 427 650	714 20 420
Seal kit FPM (FKM)	971 427 640	714 20 410
Oil filter ⁵⁾	EK 960 04	EK 960 04
Oil filter bypass	712 30 570	712 30 570

¹⁾ Pumps with European and Japanese motors have G, pumps with US voltages motors have NPT

²⁾ Wide range motor: 210-240 & 360-420 V ± 5%, 50 Hz and 210-260 & 360-460 V ± 5%, 60 Hz

³⁾ With NEMA type electrical connections without terminal board

⁴⁾ Please indicate when ordering a pump

⁵⁾ Not included in maintenance kit

SOGEVAC SV 100 B

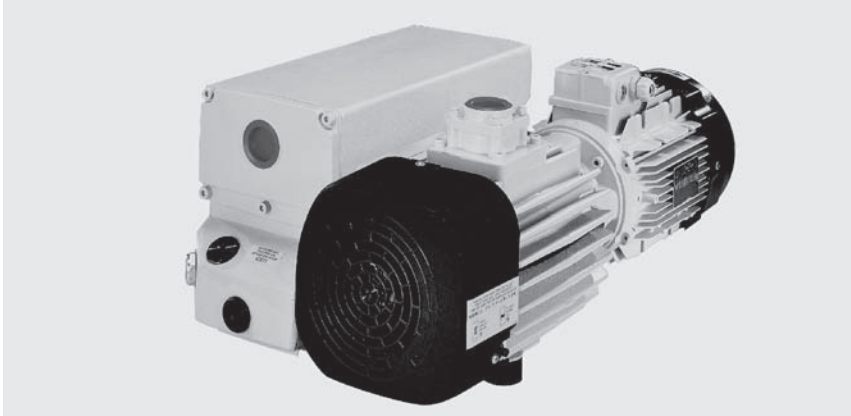

SOGEVAC SV 100 B

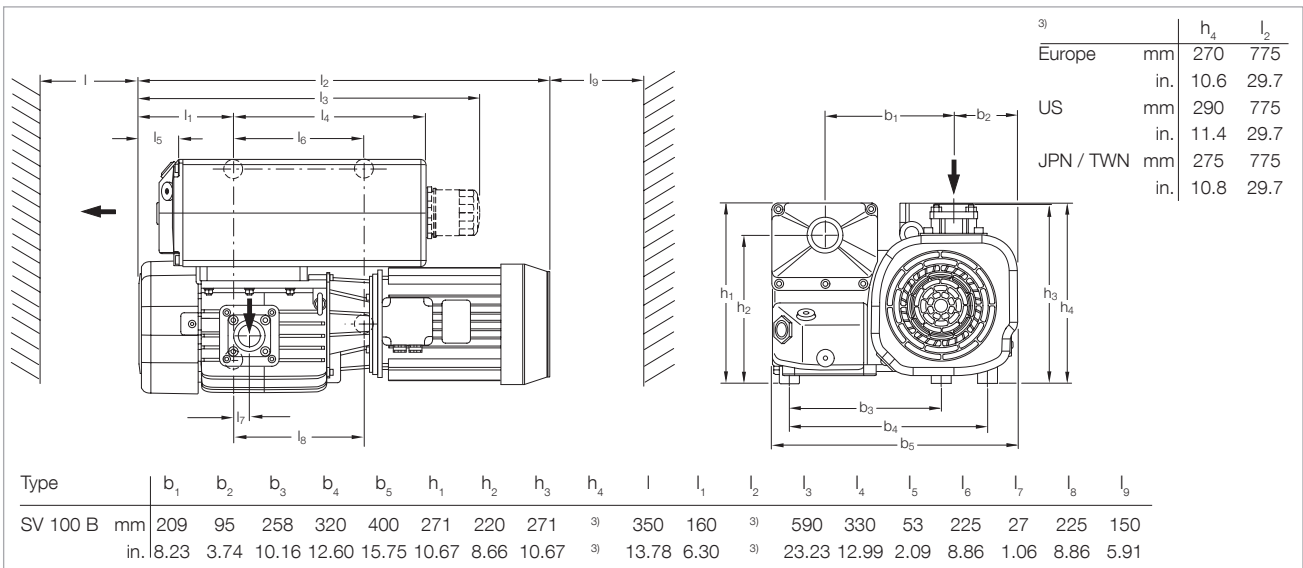

Dimensional drawing for the SOGEVAC SV 100 B

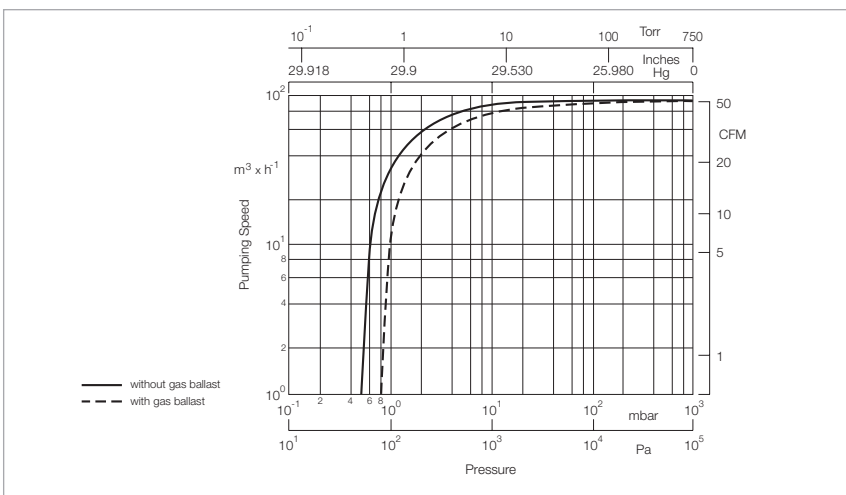

Pumping speed characteristics of the SOGEVAC SV 100 B at 50 Hz
(60 Hz curves at the end of the chapter)

Technical Data

SOGEVAC SV 100 B

		50 Hz	60 Hz
Nominal speed ¹⁾	m ³ /h (cfm)	97.5 (57.4)	117.0 (68.9)
Pumping speed ¹⁾	m ³ /h (cfm)	87.5 (51.5)	105.0 (61.8)
Ultimate total pressure without gas ballast ¹⁾	mbar (Torr)	≤ 0.5 (≤ 0.4)	≤ 0.5 (≤ 0.4)
Ultimate total pressure ¹⁾			
with standard gas ballast ²⁾	mbar (Torr)	≤ 1.5 (≤ 1.1)	≤ 1.5 (≤ 1.1)
with small gas ballast ²⁾	mbar (Torr)	≤ 0.8 (≤ 0.6)	≤ 0.8 (≤ 0.6)
Water vapor tolerance ¹⁾			
with standard gas ballast ²⁾	mbar (Torr)	30.0 (22.5)	30.0 (22.5)
with small gas ballast ²⁾	mbar (Torr)	10.0 (7.5)	10.0 (7.5)
Water vapor capacity			
with standard gas ballast ²⁾	kg/h (qt/hr)	1.60 (1.69)	1.70 (1.80)
with small gas ballast ²⁾	kg/h (qt/hr)	0.45 (0.48)	0.60 (0.63)
Oil capacity	l (qt)	2.0 (2.1)	2.0 (2.1)
Mean noise level ³⁾	dB(A)	61	64
Admissible ambient temperature	°C (°F)	12 to 40 (54 to 104)	12 to 40 (54 to 104)
Motor power	kW (hp)	2.2 (3.5)	3.5 (5.0)
Nominal speed	min ⁻¹ (rpm)	1500 (1500)	1800 (1800)
Type of protection	IP	55-F	55-F
Materials (materials in contact with the gas)		Steel, cast iron, Aluminium, Bronze, FPM (FKM), Glass, Polyamid 6.6, Filter material (Polymers, Paper), Epoxy resin & Glass fibre	Steel, cast iron, Aluminium, Bronze, FPM (FKM), Glass, Polyamid 6.6, Filter material (Polymers, Paper), Epoxy resin & Glass fibre
Weight (with oil filling)	kg (lbs)	92 (203)	93 (205)
Dimensions (L x W x H)			
Europe	mm (in.)	755 x 400 x 270 (29.7 x 15.7 x 10.6)	755 x 400 x 270 (29.7 x 15.7 x 10.6)
US	mm (in.)	755 x 400 x 290 (29.7 x 15.7 x 11.4)	755 x 400 x 290 (29.7 x 15.7 x 11.4)
JPN / TWN	mm (in.)	755 x 400 x 275 (29.7 x 15.7 x 10.8)	755 x 400 x 275 (29.7 x 15.7 x 10.8)
Connection (inside thread) ⁴⁾			
Intake	G or NPT	1 1/4"	1 1/4"
Exhaust	G or NPT	1 1/4"	1 1/4"

¹⁾ To DIN 28 400 and following numbers

²⁾ Ordering Information, see next page

³⁾ Operated at the ultimate pressure without gas ballast, free-field measurement at a distance of 1 m (3.5 ft)

⁴⁾ Pumps with European and Japanese motors have G, pumps with US (NEMA) motors have NPT

Ordering Information

SOGEVAC SV 100 B

50/60 Hz

	Part No.
SOGEVAC SV 100 B ¹⁾ with three-phase motor, without gas ballast, without oil filter 230/400 V, 50 Hz and 460 V, 60 Hz (CEI)	960 500
with three-phase motor, without gas ballast, with oil filter 230/400 V, 50 Hz and 460 V, 60 Hz (CEI)	960 502
with three-phase motor, with small gas ballast, without oil filter 230/400 V, 50 Hz and 460 V, 60 Hz (CEI)	960 501
230/460 V, 60 Hz and 400 V, 50 Hz (NEMA)	960 511
230/400 V, 50/60 Hz and 460 V, 60 Hz (CEI)	960 521
200 V, 50/60 Hz (JIS)	960 516
with three-phase motor, with small gas ballast, with oil filter 230/400 V, 50 Hz and 460 V, 60 Hz (CEI)	960 503
230/460 V, 60 Hz and 400 V, 50 Hz (NEMA)	960 513
230/400 V, 50/60 Hz and 460 V, 60 Hz (CEI)	960 523
200 V, 50/60 Hz (JIS)	960 518
with three-phase motor, with standard gas ballast, without oil filter 230/400 V, 50 Hz and 460 V, 60 Hz (CEI)	960 505
230/460 V, 60 Hz and 400 V, 50 Hz (NEMA)	960 512
230/400 V, 50/60 Hz and 460 V, 60 Hz (CEI)	960 522
200 V, 50/60 Hz (JIS)	960 517
with three-phase motor, with standard gas ballast, with oil filter 230/400 V, 50 Hz and 460 V, 60 Hz (CEI)	960 507
230/460 V, 60 Hz and 400 V, 50 Hz (NEMA)	960 514
230/400 V, 50/60 Hz and 460 V, 60 Hz (CEI)	960 524
200 V, 50/60 Hz (JIS)	960 519
Other voltages/frequencies ²⁾	upon request
Filling with special oil ²⁾	upon request
Accessories	
RUVAC adapter (WA/WS 251/501)	971 448 740
Exhaust filter cartridge AFE SV65/100B ³⁾	714 17 300
Spare Parts	
Maintenance kit	971 427 690
Repair kit	971 427 680
Seal kit FPM (FKM)	971 427 670
Oil filter ⁴⁾	EK 960 05
Oil filter bypass	712 30 570

¹⁾ Pumps with European and Japanese motors have G, pumps with US voltages motors have NPT without terminal board

²⁾ Please indicate when ordering a pump

³⁾ 2 cartridges needed per pump

⁴⁾ Not included in maintenance kit

SOGEVAC SV 120 B

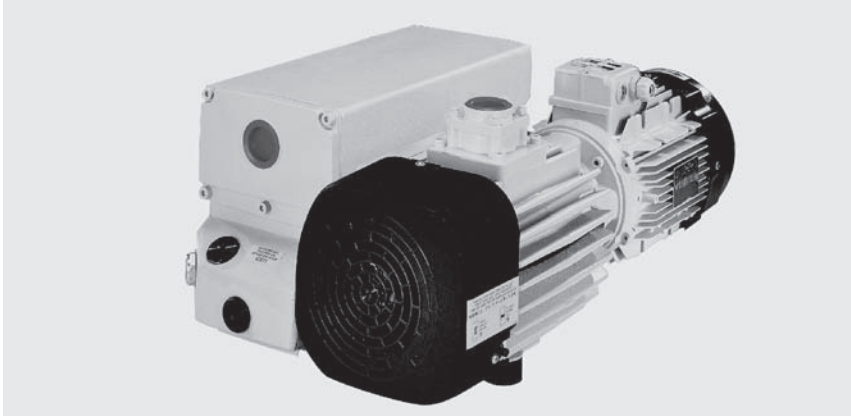

SOGEVAC SV 120 B

Advantages to the User

- Best effective pumping speed in this class
- Good pump temperature due to the cooling coil, ideal for harsh applications. Optimal oil life time thus reached
- Wide range motor as standard
- Optimized integrated lubrication without external pipes
- Integrated oil recovery system and anti suckback valve
- Low noise level

Typical Applications

- Oil purification
- Plastic & rubber injection presses
- Lamination
- ATEX and O₂ applications
- ... and more

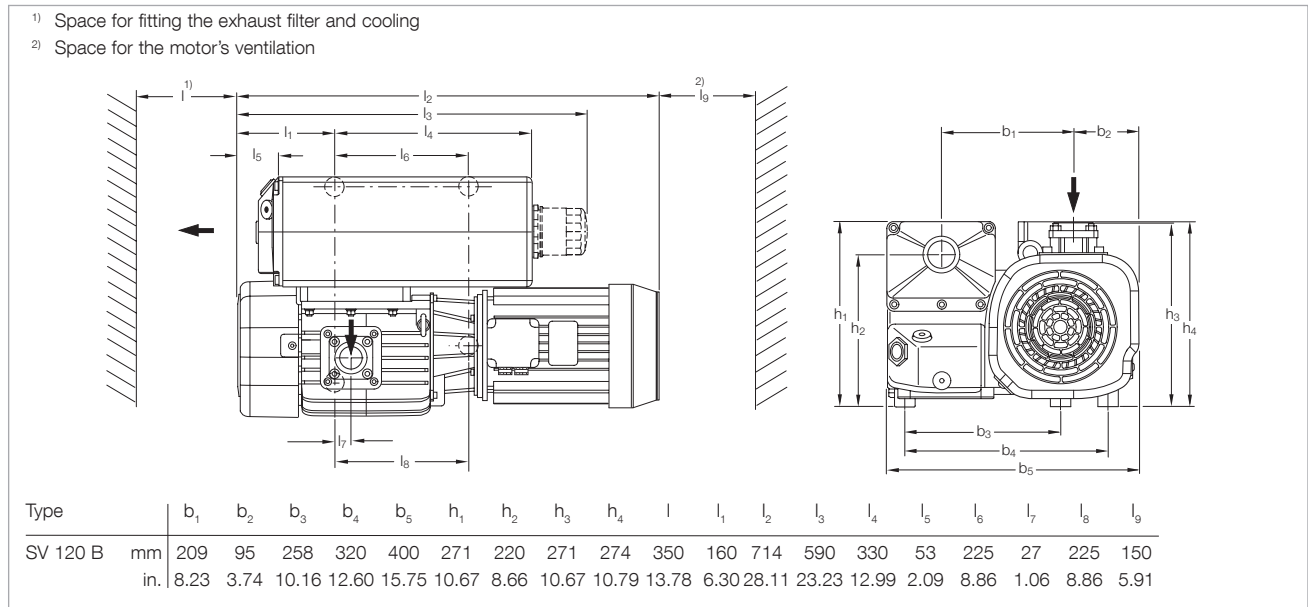

Dimensional drawing for the SOGEVAC SV 120 B

Technical Data

SOGEVAC SV 120 B

		50 Hz	60 Hz
Nominal speed ¹	m ³ /h (cfm)	130 (77)	147 (86)
Pumping speed (according to PNEUROP) ¹	m ³ /h (cfm)	110 (65)	122 (72)
Ultimate total pressure without gas ballast ¹	mbar (Torr)	≤ 0.5 (≤ 0.4)	≤ 0.5 (≤ 0.4)
Ultimate total pressure ¹ with gas ballast ²⁾	mbar (Torr)	≤ 1.5 (≤ 1.1)	≤ 1.5 (≤ 1.1)
Water vapor tolerance ¹ with standard gas ballast ²⁾	mbar (Torr)	30.0 (22.5)	30.0 (22.5)
Water vapor capacity with standard gas ballast ²⁾	kg/h (qt/hr)	1.60 (1.69)	1.70 (1.80)
Mean noise level (according to DIN 466535) ³⁾	dB(A)	61	64
Admissible ambient temperature	°C (°F)	12 to 40 (54 to 104)	12 to 40 (54 to 104)
Motor power 3 ~ (with IEC Euro (NEMA) motor)	kW (hp)	2.4 (3.3)	3.2 (4.4)
Mains voltage and frequency 3 ~ motor	V	220-230 and 380-400 V ± 10%, 50 Hz 230 and 400-460 V ± 10%, 60 Hz	220-230 and 380-400 V ± 10%, 50 Hz 230 and 400-460 V ± 10%, 60 Hz
Rated rotational speed	min ⁻¹ (rpm)	1500 (1500)	1800 (1800)
Type of protection	IP	55	55
Isolation class 3 ~ motor		F	F
Leak rate	mbar x l/s	≤ 1 x 10 ⁻³	≤ 1 x 10 ⁻³
Materials (materials in contact with the gas)		Steel, cast iron, Aluminium, Bronze, FPM (FKM), Glass, Polyamid 6.6, Filter material (Polymers, Paper), Epoxy resin & Glass fibre	Steel, cast iron, Aluminium, Bronze, FPM (FKM), Glass, Polyamid 6.6, Filter material (Polymers, Paper), Epoxy resin & Glass fibre
Oil capacity	l (qt)	2.0 (2.1)	2.0 (2.1)
Net weight (with oil filling)	kg (lbs)	84 (185)	84 (185)
Dimensions (L x W x H)	mm (in.)	755 x 400 x 290 (29.7 x 15.7 x 11.4)	755 x 400 x 290 (29.7 x 15.7 x 11.4)
Connection (inside thread) ⁴⁾			
Intake	G or NPT	1 1/4"	1 1/4"
Exhaust	G or NPT	1 1/4"	1 1/4"

¹⁾ To DIN 28 400 and following numbers

²⁾ Ordering Information see next page

³⁾ Operated at the ultimate pressure without gas ballast, free-field measurement at a distance of 1 m (3.5 ft)

⁴⁾ Pumps with European and Japanese motors have G,
pumps with US (NEMA) motors have NPT

Ordering Information

SOGEVAC SV 120 B

50/60 Hz

	Part No.
SOGEVAC SV 120 B ¹⁾ with three-phase motor 230/400 V ±10%, 50 Hz and 230/400/460 V ±10%, 60 Hz	
without gas ballast, without oil filter	960 550 V (upon request)
with small gas ballast, without oil filter	960 551
without gas ballast, with oil filter	960 552 V (upon request)
with small gas ballast, with oil filter	960 553
with standard gas ballast, without oil filter	960 572
with standard gas ballast, with oil filter	960 557
Other voltages/frequencies ²⁾	upon request
Filling with special oil ²⁾	upon request
Accessories	
RUVAC adapter (WA/WS 251/501)	971 448 740
Exhaust filter cartridge AFE SV65/100B ³⁾	714 17 300
Spare Parts	
Maintenance kit	971 427 690
Repair kit	EK 971 445 151
Oil filter ⁴⁾	EK 960 05
Oil filter bypass	712 30 570

¹⁾ Pumps with European and Japanese motors have G, pumps with US voltages motors have NPT without terminal board

²⁾ Please indicate when ordering a pump

³⁾ 2 cartridges needed per pump

⁴⁾ Not included in maintenance kit

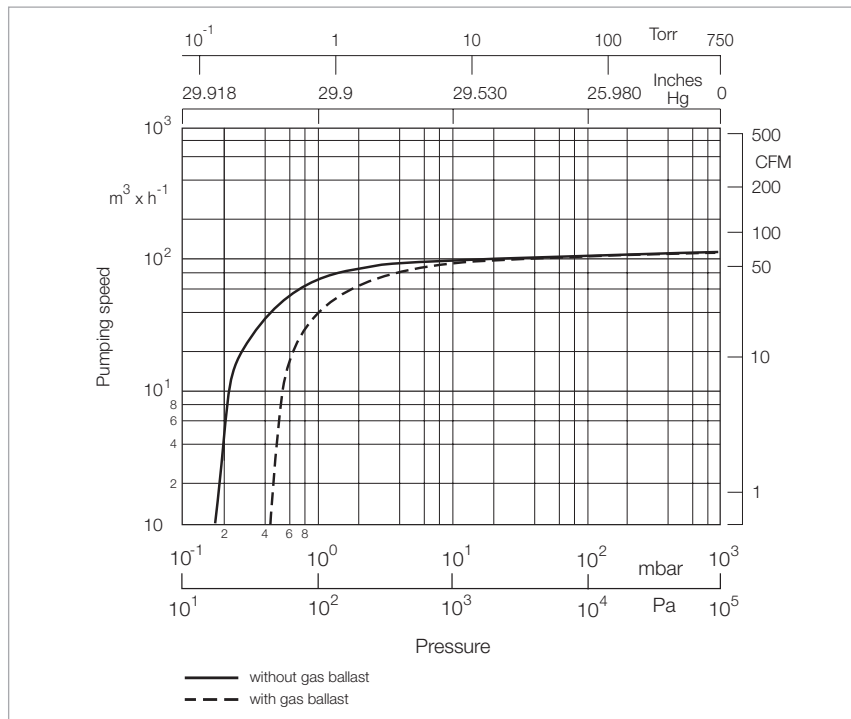

Pumping speed characteristics of the SOGEVAC SV 120 B at 50 Hz
(60 Hz curves at the end of the chapter)

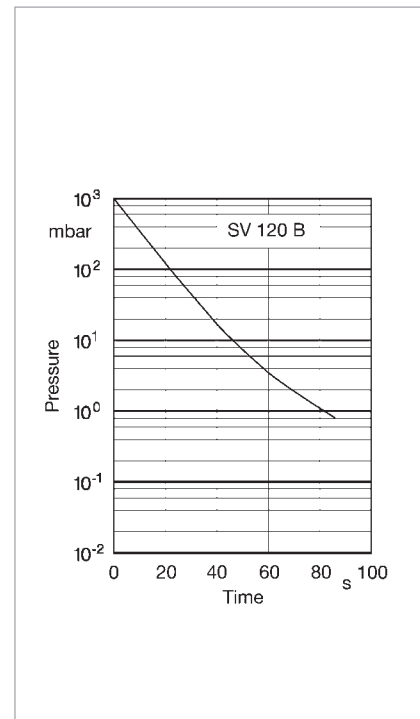

Pump-down characteristics of a 300 l vessel
at 50 Hz

SOGEVAC SV 200

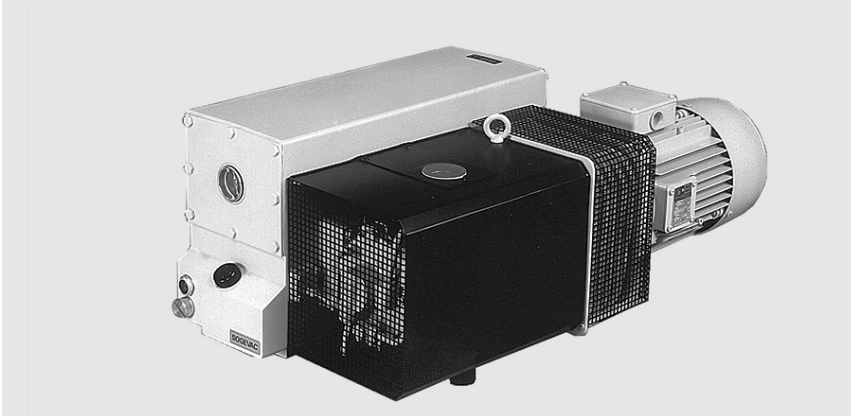

SOGEVAC SV 200

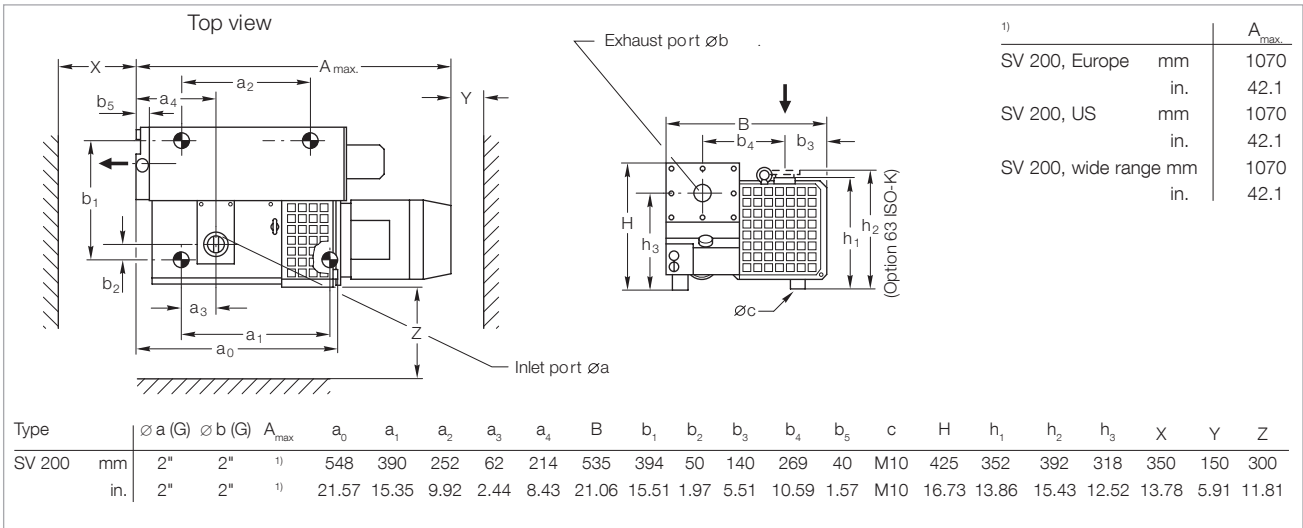

Dimensional drawing for the SOGEVAC SV 200, European version

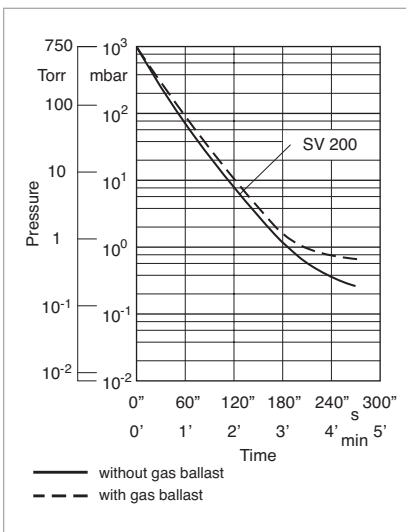

Pump-down characteristics of a 1000 l vessel at 50 Hz

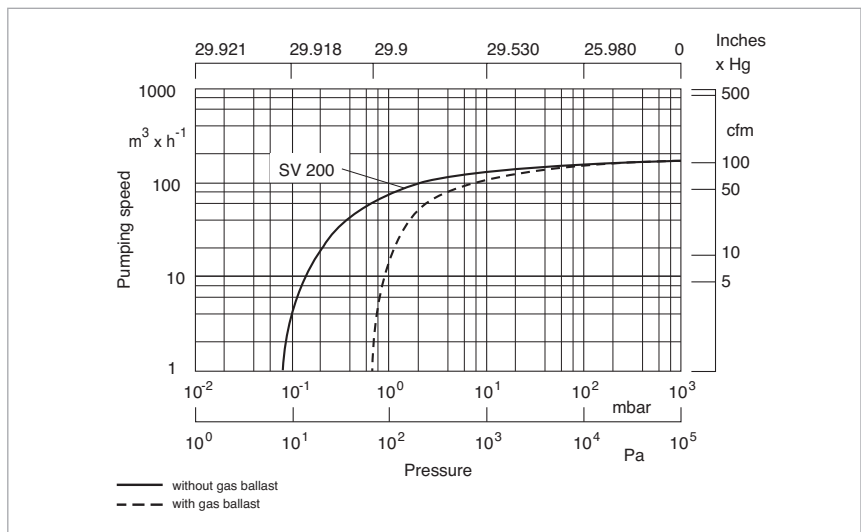

Pumping speed characteristics of the SOGEVAC SV 200 at 50 Hz (60 Hz curves at the end of the chapter)

Technical Data

SOGEVAC SV 200

		50 Hz	60 Hz
Nominal speed ¹⁾	m ³ /h (cfm)	180 (106.0)	220 (129.5)
Pumping speed ¹⁾	m ³ /h (cfm)	170 (100.1)	200 (117.8)
Ultimate total pressure without gas ballast ¹⁾	mbar (Torr)	≤ 8 x 10 ⁻² (≤ 6 x 10 ⁻²)	≤ 8 x 10 ⁻² (≤ 6 x 10 ⁻²)
Ultimate total pressure with gas ballast ¹⁾	mbar (Torr)	≤ 0.7 (≤ 0.5)	≤ 0.7 (≤ 0.5)
Water vapor tolerance with standard gas ballast ¹⁾	mbar (Torr)	30.0 (22.5)	40.0 (30.0)
Water vapor tolerance with big gas ballast ²⁾	mbar (Torr)	50.0 (37.5)	50.0 (37.5)
Water vapor capacity with standard gas ballast	kg/h (qt/hr)	3.4 (3.6)	5.4 (5.7)
Oil capacity, min. / max.	l (qt)	5.0 (5.3) / 9.0 (9.5)	5.0 (5.3) / 9.0 (9.5)
Noise level ³⁾	dB(A)	69	73
Admissible ambient temperature	°C (°F)	12 to 40 (54 to 104)	12 to 40 (54 to 104)
Motor power	kW (hp)	4.0 (7.5)	4.6 (7.5)
Nominal speed	min ⁻¹ (rpm)	1450 (1450)	1750 (1750)
Type of protection	IP	55	TEFC/55 ⁴⁾
Materials (materials in contact with the gas)		Steel, cast iron, Aluminium, FPM (FKM), Glass, Polyamid 6.6, Filter material (Polymers, Paper), Epoxy resin & Glass fibre	Steel, cast iron, Aluminium, FPM (FKM), Glass, Polyamid 6.6, Filter material (Polymers, Paper), Epoxy resin & Glass fibre
Weight (with oil filling)	kg (lbs)	150 (331)	160 (353)
Connections ⁵⁾			
Intake, Thread	G or NPT	2"	2"
Exhaust, Thread	G or NPT	2"	2"

¹⁾ To DIN 28 400 and following numbers

²⁾ Ordering Information see Chapter "Accessories"

³⁾ Operated at the ultimate pressure without gas ballast, free-field measurement at a distance of 1 m (3.5 ft)

⁴⁾ CEI motor (Europe) 50/60 Hz has IP 55, NEMA motor (North and South America) has TEFC

⁵⁾ Pumps with European and Japanese motors have G, pumps with US (NEMA) motors have NPT

Ordering Information

SOGEVAC SV 200

50/60 Hz

	Part No.
SOGEVAC SV 200 ¹⁾ with three-phase motor, without gas ballast 230/400 V, 50 Hz and 460 V, 60 Hz (CEI) ²⁾ 200 V, 50/60 Hz (JIS)	109 26 955 26
with three-phase motor and integrated gas ballast valve 230/400 V, 50 Hz and 460 V, 60 Hz (CEI) ²⁾ 208 - 230/460 V, 60 Hz (NEMA) and 400 V, 50 Hz ²⁾ 200 V, 50/60 Hz (JIS)	109 27 950 27 955 27
Other voltages/frequencies ³⁾	upon request
Filling with special oil ³⁾	upon request
Accessories	
Adaptor for Roots pump ^{3), 4)} RUVAC 501 (BR 2) RUVAC 1001 (BR 2)	953 90 953 91
Mounting pedestal for fitting to a Roots pump	711 19 209
Oil level monitor ^{3), 4)}	953 96
Thermal switch ^{3), 4)}	951 36
Exhaust filter gauge, mechanical ^{3), 4)}	951 94
Exhaust filter monitoring switch, electric ³⁾	upon request
Manual gas ballast ^{3), 4)}	951 30
Gas ballast valve, electromagnetic 24 V DC ^{3), 4)}	951 31
Two gas ballast valves ³⁾	upon request
Water cooling with thermostatic valve ³⁾	upon request
Spare Parts	
Oil filter	EK 960 06
Oil filter bypass	712 30 570
Exhaust filter cartridge (4x required) AFE SV40-SV100 / SV 180/200	710 64 763
Set of gaskets NBR (standard)	971 97 552
Set of gaskets FPM (FKM)	714 36 730
Repair kit complete	714 36 190
Pump module complete	714 36 770

¹⁾ Pumps with European and Japanese motors have G,
pumps with US (NEMA) have NPT

²⁾ IEC motor (Europe) 50/60 Hz have IP 55, NEMA motor have TEFC

³⁾ Please indicate when ordering a pump

⁴⁾ Can be retrofitted

Note: Further pump options upon request (for example, water cooled pumps)

SOGEVAC SV 300 B



SOGEVAC SV 300 B

Advantages to the User

- Lowest pump temperature on the market: ideal for harsh applications. Optimal oil life time thus reached
- Integrated exhaust filters with low oil mist flow: long filter life time
- Optimized integrated lubrication without external pipes: yellow metal free as standard
- Integrated oil recovery system and anti-suckback valve
- Low noise level
- High reliability due to separate greased ball bearings (30.000 h life)
- Variant concept
- Best ultimate pressure
- Big oil volume for long oil life time

Typical Applications

- Coating systems and load locks
- Oil purification
- Plastic & rubber injection presses
- Heat treatment / Metallurgy
- Lamination
- ATEX and O₂ applications
- ... and more

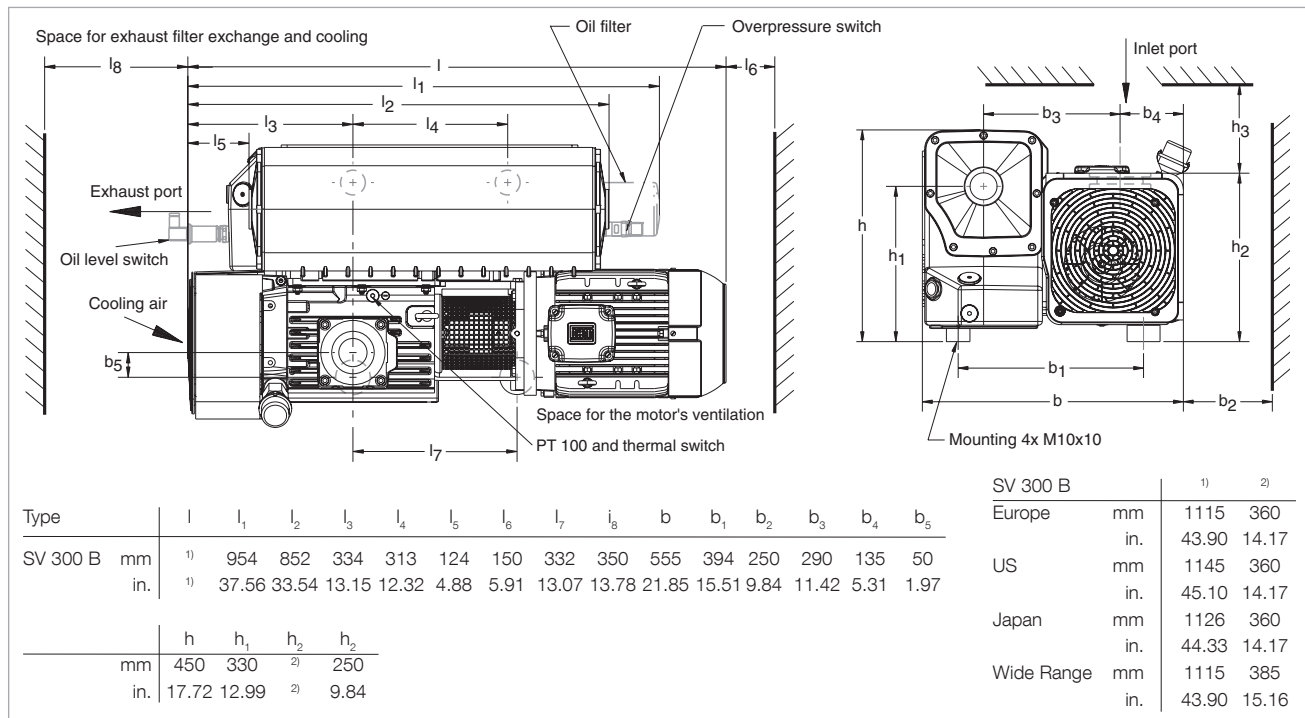

Dimensional drawing for the SOGEVAC SV 300 B, European version

Technical Data

SOGEVAC SV 300 B

		50 Hz	60 Hz
Nominal speed ¹⁾	m ³ /h (cfm)	280 (165)	340 (200)
Pumping speed (according to PNEUROPE) ¹⁾	m ³ /h (cfm)	240 (141)	290 (171)
Ultimate total pressure without gas ballast ¹⁾	mbar (Torr)	≤ 0.08 (≤ 0.06)	≤ 0.08 (≤ 0.06)
Ultimate total pressure with small gas ballast 4 Nm ³ /h ¹⁾	mbar (Torr)	≤ 0.5 (≤ 0.4)	≤ 0.5 (≤ 0.4)
Ultimate total pressure with standard gas ballast 7.5 Nm ³ /h also for electromagnetic gas ballast 10 Nm ³ /h ¹⁾	mbar (Torr)	≤ 0.7 (≤ 0.5)	≤ 0.7 (≤ 0.5)
Ultimate total pressure with big gas ballast 15 Nm ³ /h ¹⁾	mbar (Torr)	≤ 2.0 (≤ 1.5)	≤ 2.0 (≤ 1.5)
Ultimate total pressure with 2 big gas ballasts 28 Nm ³ /h ¹⁾	mbar (Torr)	≤ 3.0 (≤ 2.3)	≤ 3.0 (≤ 2.3)
Water vapor tolerance with small ballast 4 Nm ³ /h	mbar (Torr)	4 (3) with turbine 220 mm	5 (4) with turbine 220 mm
Water vapor capacity with small ballast 4 Nm ³ /h	kg/h (qt/hr)	0.4 (0.4) with turbine 220 mm	0.6 (0.6) with turbine 220 mm
Water vapor tolerance with standard gas ballast 7.5 Nm ³ /h also for electromagnetic gas ballast 10 Nm ³ /h ²⁾	mbar (Torr)	10.0 (7.5) with turbine 220 mm 40.0 (30.0) with turbine 150 mm ⁶⁾	12.0 (9.0) with turbine 220 mm 50.0 (37.5) with turbine 150 mm ⁶⁾
Water vapor capacity with standard gas ballast 7.5 Nm ³ /h also for electromagnetic gas ballast 10 Nm ³ /h	kg/h (qt/hr)	1.3 (1.4) with turbine 220 mm 6.0 (6.4) with turbine 150 mm ⁶⁾	1.8 (1.9) with turbine 220 mm 8.0 (8.5) with turbine 150 mm ⁶⁾
Water vapor tolerance with big gas ballast 15 Nm ³ /h ²⁾	mbar (Torr)	70.0 (52.5) with turbine 150 mm ⁶⁾	70.0 (52.5) with turbine 150 mm ⁶⁾
Water vapor capacity with big gas ballast 15 Nm ³ /h ²⁾	kg/h (qt/hr)	11 (12) with turbine 150 mm ⁶⁾	14 (15) with turbine 150 mm ⁶⁾
Water vapor tolerance with 2 big gas ballasts 28 Nm ³ /h ²⁾	mbar (Torr)	95 (72) with turbine 150 mm ⁶⁾	95 (72) with turbine 150 mm ⁶⁾
Water vapor capacity with 2 big gas ballasts 28 Nm ³ /h ²⁾	kg/h (qt/hr)	15 (16) with turbine 150 mm ⁶⁾	17 (18) with turbine 150 mm ⁶⁾
Noise level (according to DIN 466535) ³⁾	dB(A)	72	76
Admissible ambient temperature	°C (°F)	12 to 40 (54 to 104)	12 to 40 (54 to 104)
Motor power 3 ~ (with IEC Euro motor) ⁴⁾	kW (hp)	5.5 (7.5)	6.3 (8.6)
Mains voltage and frequency 3 ~ motor	V	see Ordering Information	see Ordering Information
Nominal speed	min ⁻¹ (rpm)	1500 (1500)	1800 (1800)
Type of protection	IP	55	55
Isolation class 3 ~ motor		F	F
Leak rate	mbar x l/s	≤ 1 x 10 ⁻³	≤ 1 x 10 ⁻³
Oil capacity, min. / max.	l (qt)	8.5 (9.0) / 11.5 (12.2)	8.5 (9.0) / 11.5 (12.2)
Net weight (with oil filling) dependent on the motor	kg (lbs)	223 (493)	225 (497)
Connections ⁵⁾			
Intake, Thread	G or NPT	2"	2"
Exhaust, Thread	G or NPT	2"	2"

¹⁾ To DIN 28 400 and following numbers

²⁾ Ordering Information see Chapter "Accessories"

³⁾ Operated at the ultimate pressure without gas ballast, free-field measurement at a distance of 1 m (3.5 ft)

⁴⁾ Versions with NEMA motor have 10 hp motors

⁵⁾ Pumps with European and Japanese motors have G, pumps with US (NEMA) motors have NPT

⁶⁾ Standard turbine 220 mm. Special turbine 150 mm can be retrofitted

Ordering Information

SOGEVAC SV 300 B

50/60 Hz

	Part No.
SOGEVAC SV 300 B ¹⁾ with oil filter with three-phase motor, without gas ballast, 230/400 V ± 10%, 50 Hz and 460 V ± 10%, 60 Hz (CEI) ²⁾	960 700
with small gas ballast, 230/400 V ± 10%, 50 Hz and 460 V ± 10%, 60 Hz (CEI) ²⁾	960 701
208 V ± 10%, 230/460 V ± 10%, 60 Hz and 400 V ± 10%, 50 Hz (NEMA) ²⁾	960 706
200 V + 10% - 15%, 50/60 Hz (JIS) ¹⁾	960 711 V
with standard gas ballast, 230/400 V ± 10%, 50 Hz and 460 V ± 10%, 60 Hz (CEI) ²⁾	960 702
208 V ± 10%, 230/460 V ± 10%, 60 Hz and 400 V ± 10%, 50 Hz (NEMA) ²⁾	960 707
200 V + 10% - 15%, 50/60 Hz (JIS) ¹⁾	960 712
with big gas ballast, 230/400 V ± 10%, 50 Hz and 460 V ± 10%, 60 Hz (CEI) ²⁾	960 703 ³⁾
208 V ± 10%, 230/460 V ± 10%, 60 Hz and 400 V ± 10%, 50 Hz (NEMA) ²⁾	960 708 ³⁾
200 V + 10% - 15%, 50/60 Hz (JIS) ¹⁾	960 713 V ³⁾
with Wide range motor, 200 V - 15% to 230 V + 10% / 380 to 400 V ± 10%, 50 Hz, CTP; 5.5 kW & 200 V - 15% to 230 V + 10% / 380 to 400 V ± 10% and 460 V ± 10%, 60 Hz, CTP; 6.6 kW	
with small gas ballast	960 716 V ⁴⁾
with standard gas ballast	960 717 ⁴⁾
with big gas ballast	960 718 ^{3, 4)}

¹⁾ Pumps with European and Japanese motors have G, pumps with US (NEMA) have NPT

²⁾ IEC motor (Europe) 50/60 Hz have IP 55, NEMA motor have TEFC without terminal board

³⁾ With small 150 mm turbine

⁴⁾ F and P inlet

Full option oil box with connections (bores and plugs) for

- G 3/8" for external oil filtration

- oil level sensor (vibration)

- thermostatic valve

- temperature sensor Pt100 and switch

Note: Further pump options upon request (for example, water cooled pumps)

Ordering Information

SOGEVAC SV 300 B

50/60 Hz

	Part No.
Accessories	
Adaptor for Roots pump ^{1), 2)} RUVAC 501 (BR 2) RUVAC 1001 (BR 2)	971 463 880 971 463 890
Mounting pedestal for fitting to a Roots pump	971 456 590
Oil level monitor ^{1), 3)} (several types are available)	712 21 992V or 971 458 110 (yellow metal free)
Thermal switch (105 °C) ^{2), 3)}	971 463 930
Pt100 sensor ²⁾	971 464 020
Exhaust filter gauge, mechanical ^{1), 2)}	951 94
Exhaust filter monitoring switch, electric ^{1), 3)}	712 22 360
Manual gas ballast kit ²⁾ (incl. small, standard and big)	971 464 130
Gas ballast valve, electromagnetic 24 V DC ^{1), 2)} with end plate without end plate	971 465 380 971 465 680
Two gas ballast valves ¹⁾	upon request
Water cooling with thermostatic valve only with all option oil casing ³⁾	EK 971 449 111
Oil filter bypass ^{1), 2)}	712 30 570
Spare Parts	
Oil filter	EK 960 06
Exhaust filter cartridge (3x required) AFE SV 300 B - SV 750 B	971 431 120
Set of gaskets FPM (FKM) (standard)	971 464 950
Repair kit	971 464 960
Maintenance kit	971 464 970
Generator kit G 2" NPT 2"	971 447 390 971 458 970
Turbine 150 mm kit ^{2), 3)}	EK 650 3 195

¹⁾ Please indicate when ordering a pump

²⁾ Can be retrofitted

³⁾ Can be retrofitted by LV Service

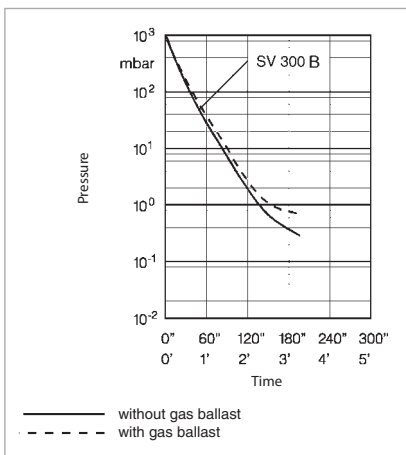

Pump-down characteristics of a 1000 l vessel at 50 Hz

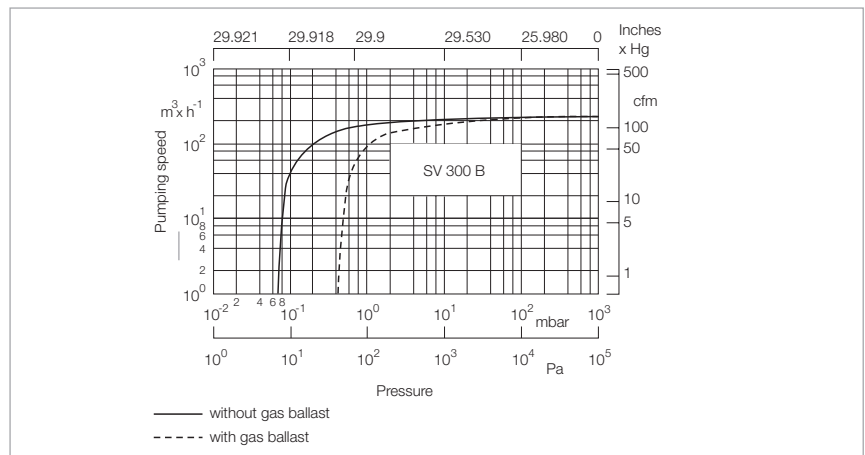

Pumping speed characteristics of the SOGEVAC SV 300 B at 50 Hz (60 Hz curves at the end of the chapter)

SOGEVAC SV 470 B(F) and SV 570 B(F)



SOGEVAC SV 470 B and 570 B

Advantages to the User

- Very low rotational speed increases the lifetime of the pump and leads to noise level reduction
- Extremely low noise level in any working conditions
- Reduced number of oil pipes
- Reduced operational costs
- Long lifetime of oil and exhaust filters
- Simplified maintenance thanks to an easy access to all key components
- Small size
- Air or water-cooling and many motors and options available
- Competitive price-to-performance ratio
- Adaptors for direct mounting of Roots pumps (RUVAC WH 700 to 2500)
- ATTEX IIC T3 Cat. 3 version internal/external possible
- PFPE versions available

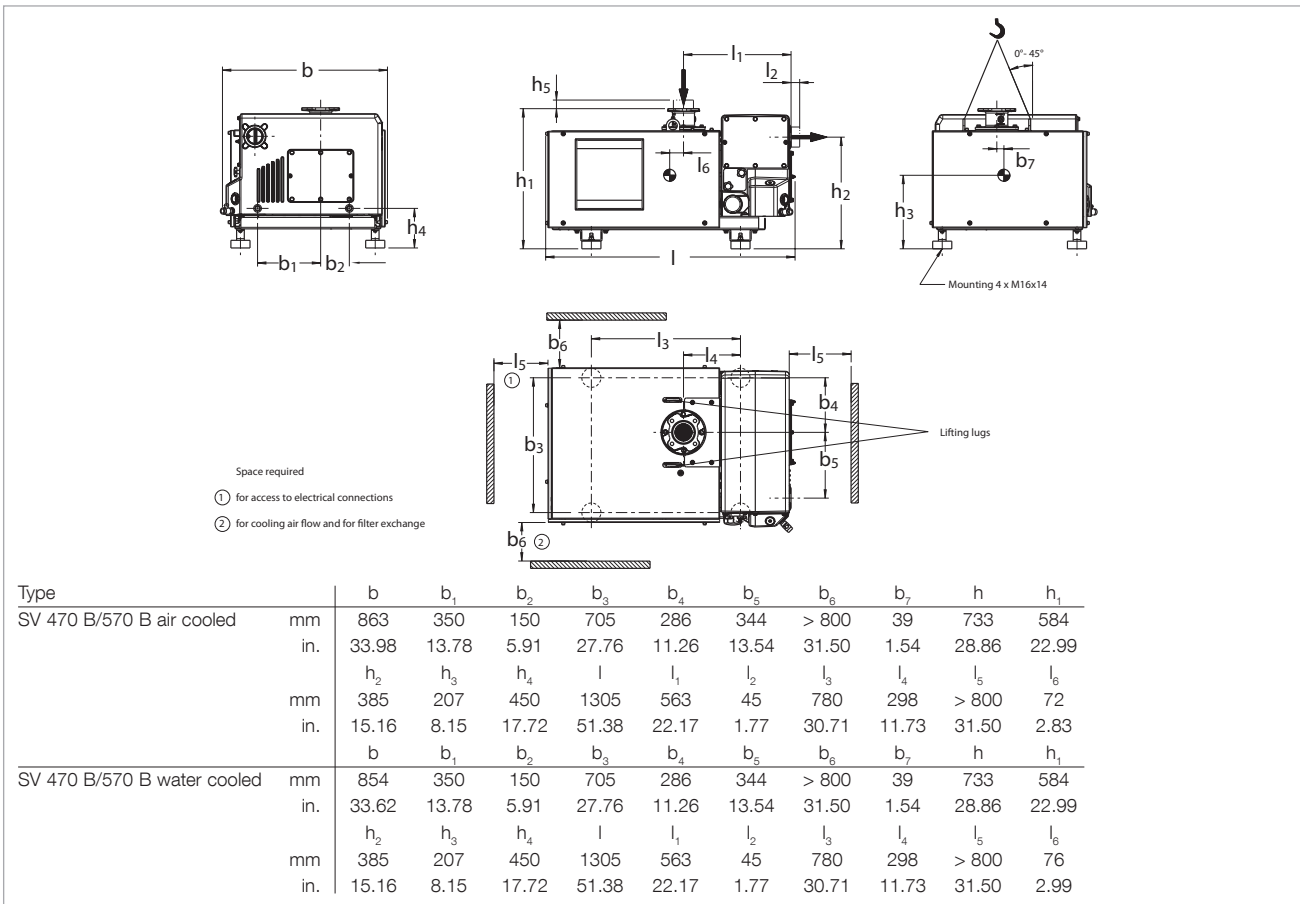

Dimensional drawing for the SOGEVAC SV 470 B and 570 B

Technical Data

SOGEVAC SV 470 B(F)

SOGEVAC SV 570 B(F)

			50 Hz	60 Hz	50 Hz
Nominal speed ¹⁾	m ³ /h (cfm)		470 (277)	570 (366)	570 (366)
Pumping speed ¹⁾	m ³ /h (cfm)		400 (236)	470 (277)	470 (277)
Ultimate total pressure without gas ballast ¹⁾	mbar (Torr)		0.08 (0.06)	0.08 (0.06)	0.08 (0.06)
Ultimate total pressure with					
1 gas ballast ¹⁾	mbar (Torr)		0.7 (0.5)	0.7 (0.5)	0.7 (0.5)
2 gas ballast valves ¹⁾	mbar (Torr)		2.0 (1.5)	2.0 (1.5)	2.0 (1.5)
Water vapor tolerance					
1 gas ballast ^{1), 2)}	mbar (Torr)		15.0 (11.0)	20.0 (15.0)	20.0 (15.0)
2 gas ballast valves ^{1), 2)}	mbar (Torr)		40.0 (30.0)	50.0 (38.0)	20.0 (15.0)
Max. perm. water vapor capacity					
1 gas ballast ^{1), 2)}	kg/h (qt/hr)		5.0 (5.3)	7.5 (8.0)	7.5 (8.0)
2 gas ballast valves ^{1), 2)}	kg/h (qt/hr)		13.0 (14.0)	17.0 (18.0)	17.0 (14.0)
Oil filling, min. / max.	l (qt)		20 / 21	20 / 21	20 / 21
Noise level (averaged) ³⁾	dB(A)		72	75 (72 for BF pumps)	75 (72 for BF pumps)
Admissible ambient temperature	°C (°F)		12 to 40 (54 to 104)	12 to 40 (54 to 104)	12 to 40 (54 to 104)
Nominal motor speed	min ⁻¹ (rpm)		820 (820)	1000 (1000)	1000 (1000)
Type of protection / Isolation	IP / -		54 / F	54 / F	54 / F
Cooling			Air (Water at BF variants)	Air (Water at BF variants)	Air (Water at BF variants)
Temperature protection					
Pump			yes	yes	yes
Motor PTC			yes	yes	yes
Water quality	TH		(4 to 8 at BF variants)	(4 to 8 at BF variants)	(4 to 8 at BF variants)
Water pressure, min. / max.	bar (psig)		(2 / 8 at BF variants)	(2 / 8 at BF variants)	(2 / 8 at BF variants)
Materials (materials in contact with the gas)			Steel, cast iron, Aluminium, FPM (FKM), Glass, Polyamid 6.6, Filter material (Polymers, Paper), Epoxy resin & Glass fibre	Steel, cast iron, Aluminium, FPM (FKM), Glass, Polyamid 6.6, Filter material (Polymers, Paper), Epoxy resin & Glass fibre	Steel, cast iron, Aluminium, FPM (FKM), Glass, Polyamid 6.6, Filter material (Polymers, Paper), Epoxy resin & Glass fibre
Dimensions (L x W x H)	mm (in.)		1305 x 863 x 733 ⁴⁾ (51.38 x 33.98 x 28.86)	1305 x 863 x 733 ⁴⁾ (51.38 x 33.98 x 28.86)	1305 x 863 x 733 ⁴⁾ (51.38 x 33.98 x 28.86)
Connection					
Intake side	Europe / US	G or NPT	3"	3"	3"
Pressure side	Europe / US	G or NPT	3"	3"	3"

¹⁾ To DIN 28 400 and following numbers, with standard gas ballast

²⁾ Please ask Leybold for more information about water cooled pumps

³⁾ Operated at the ultimate pressure without gas ballast, free-field measurement at a distance of 1 m (3.5 ft)

⁴⁾ With G 3" flanges. NPT 3" flanges add. 45 mm (1.8 in.) on pump length and height

Additional Technical Data

Air Cooling

SOGEVAC SV 470 B(F)

SOGEVAC SV 570 B(F)

50 Hz

60 Hz

50 Hz

60 Hz

		50 Hz	60 Hz	50 Hz	60 Hz
Water vapor tolerance with					
1 gas ballast ^{1), 2)}	mbar (Torr)	15 (11)	20 (15)	20 (15)	20 (15)
2 gas ballast valves ^{1), 2)}	mbar (Torr)	40 (30)	50 (37.5)	70 (52.5)	50 (37.5)
Max. perm. water vapor capacity with					
1 gas ballast ^{1), 2)}	kg/h (qt/hr)	5.0 (5.3)	7.5 (8.0)	7.5 (8.0)	7.5 (8.0)
2 gas ballast valves ^{1), 2)}	kg/h (qt/hr)	13.0 (13.8)	17.0 (18.0)	20.0 (21.2)	17.0 (14.0)
Mean noise level ³⁾	dB(A)	72	75	75	75

¹⁾ To DIN 28 400 and following numbers, with standard gas ballast

²⁾ Please ask Leybold for more information

³⁾ Operated at the ultimate pressure without gas ballast, free-field measurement at a distance of 1 m (3.5 ft)

Additional Technical Data

Water Cooling

SOGEVAC SV 470 B(F)

SOGEVAC SV 570 B(F)

50 Hz

60 Hz

50 Hz

60 Hz

		50 Hz	60 Hz	50 Hz	60 Hz
Water vapor tolerance with					
1 gas ballast ^{1), 2)}	mbar (Torr)	15 (11)	20 (15)	20 (15)	20 (15)
2 gas ballast valves ^{1), 2)}	mbar (Torr)	35 (26)	40 (30)	40 (30)	40 (30)
Max. perm. water vapor capacity with					
1 gas ballast ^{1), 2)}	kg/h (qt/hr)	5.0 (5.3)	7.5 (8.0)	7.5 (8.0)	7.5 (8.0)
2 gas ballast valves ^{1), 2)}	kg/h (qt/hr)	11.0 (11.7)	13.0 (13.8)	13.0 (13.8)	13.0 (13.8)
Mean noise level ³⁾	dB(A)	72	72	72	72
Thermostatic valve		Pos 3	Pos 3	Pos 3	Pos 3
Water quality	TH (°F)	4-8	4-8	4-8	4-8
Water pressure, min. / max.	bar (psi)	2 / 8 (29 / 114)	2 / 8 (29 / 114)	2 / 8 (29 / 114)	2 / 8 (29 / 114)
Min. water flow for 10 °C (50 °F) water warming	l/h	700	800	800	800

¹⁾ To DIN 28 400 and following numbers, with standard gas ballast

²⁾ Please ask Leybold for more information

³⁾ Operated at the ultimate pressure without gas ballast, free-field measurement at a distance of 1 m (3.5 ft)

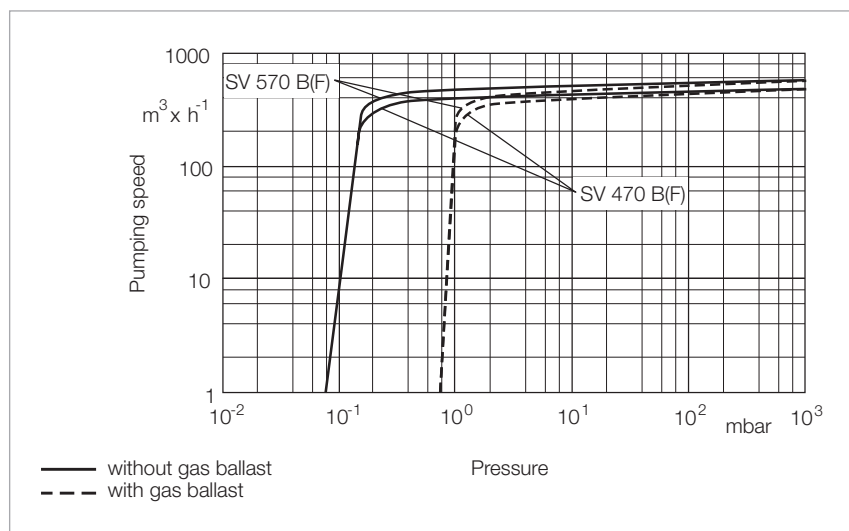

Pumping speed characteristics of the SOGEVAC SV 470 B(F) and 570 B(F) at 50 Hz operation (60 Hz curves at the end of the chapter)

Ordering Information

SOGEVAC

	SV 470 B	SV 470 BF	SV 570 B	SV 570 BF
	Part No.	Part No.	Part No.	Part No.
SOGEVAC SV ... B				
Three-phase Europe motor 230 V / 400 V, 50 Hz and 460 V, 60 Hz	960 753V	960 757V	-	-
Three-phase Europe motor 230 V / 400 V, 50 Hz	-	-	960 765V	960 767V
Three-phase world motor 230 V / 400 V, 50 + 60 Hz / 460 V, 60 Hz	960 754V	960 758V	-	-
230 V / 400 V, 50 Hz	-	-	960 766V	960 768V
NEMA Premium-Version 400 V ±10%, 50 Hz, 15 hp / 200-230 V ±10%, 60 Hz; 460 V ±10%, 60 Hz, 15 hp with terminal board	-	-	960 755V	960 759V

Accessories

Adapter for Roots pump				
RUVAC 700	9516 241V	9516 241V	9516 241V	9516 241V
RUVAC 1001	9516 242V	9516 242V	9516 242V	9516 242V
RUVAC 2001	9516 243V	9516 243V	9516 243V	9516 243V
RUVAC WHU 2500	9516 244V	9516 244V	9516 244V	9516 244V
Oil drain valve	Standard	Standard	Standard	Standard
EM gas ballast kit, 24 V DC	971 438 170	971 438 170	971 438 170	971 438 170
Gas ballast standard				
manual	9516 232V	9516 232V	9516 232V	9516 232V
permanent	9516 233V	9516 233V	9516 233V	9516 233V
2nd gas ballast valve				
EM, 24 V DC	9516 234V	9516 234V	9516 234V	9516 234V
manual	9516 235V	9516 235V	9516 235V	9516 235V
Exhaust filter monitoring gauge	951 94	951 94	951 94	951 94
Oil level check	9516 252V	9516 252V	9516 252V	9516 252V
Temperature switch	Standard	Standard	Standard	Standard
Water cooling with thermostatic valve	Upon request	Upon request	Upon request	Upon request
Exhaust filter overpressure switch	712 22 360	712 22 360	712 22 360	712 22 360
Oil filter bypass	712 36 390	712 36 390	712 36 390	712 36 390

Spare Parts

Oil filter, standard	EK 960 08	EK 960 08	EK 960 08	EK 960 08
Exhaust filter AFE SV630/SV750B/SV300B (5 pieces are required)	971 431 120	971 431 120	971 431 120	971 431 120
Intake filter element				
Paper	710 35 242	710 35 242	710 35 242	710 35 242
Metal	E 710 37 734	E 710 37 734	E 710 37 734	E 710 37 734
Activated charcoal	710 37 724	710 37 724	710 37 724	710 37 724
Polyester	712 61 508	712 61 508	712 61 508	712 61 508
Seal kit FPM (FKM)	EK971474010	EK971474010	EK971474010	EK971474010
Repair kit, complete	EK971474020	EK971474020	EK971474020	EK971474020
Generator kit	EK6700666	EK6700666	EK6700666	EK6700666
Maintenance kit	EK971474000	EK971474000	EK971474000	EK971474000

SOGEVAC SV 630 B/630 BF/750 B/750 BF



SOGEVAC SV 630 B

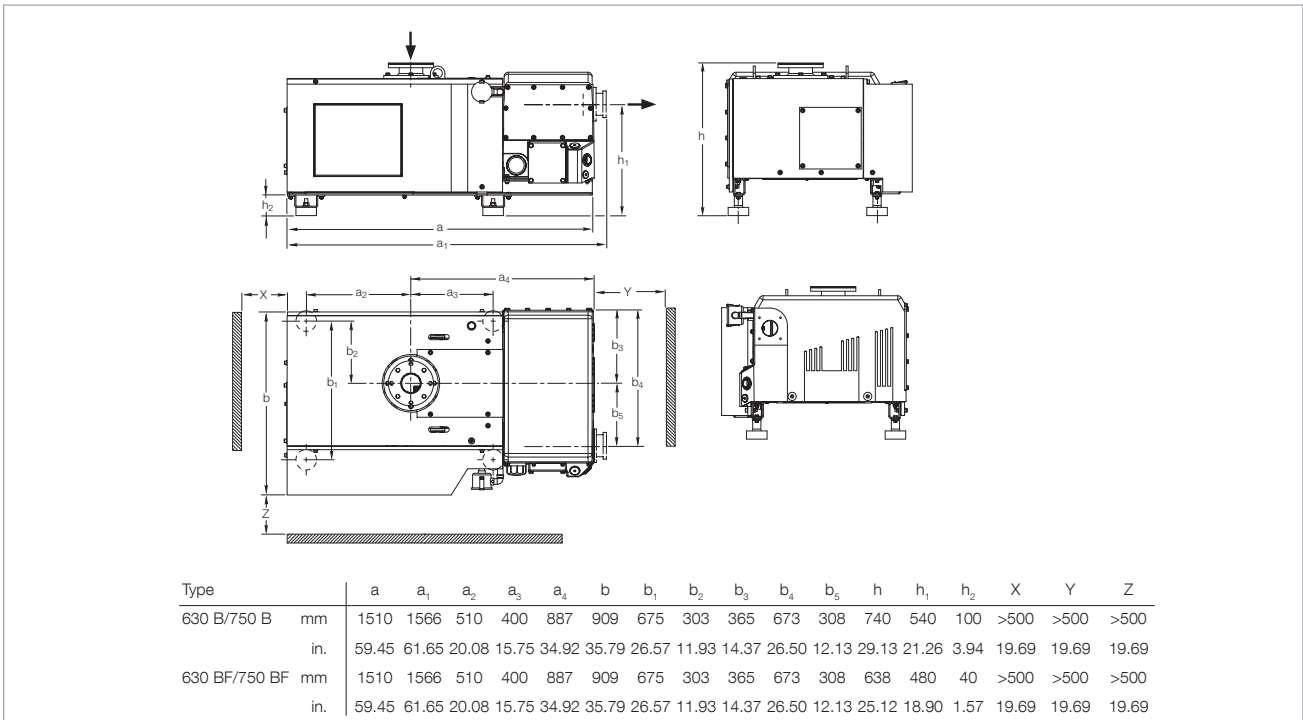

Dimensional drawing for the SOGEVAC SV 630 B, SV 630 BF, 750 B and 750 BF

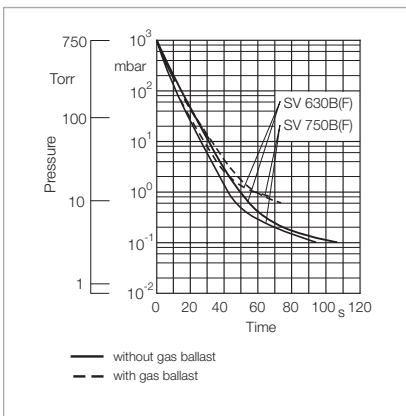

Pumpdown curve for a 1000 l vessel for 50 Hz pump operation

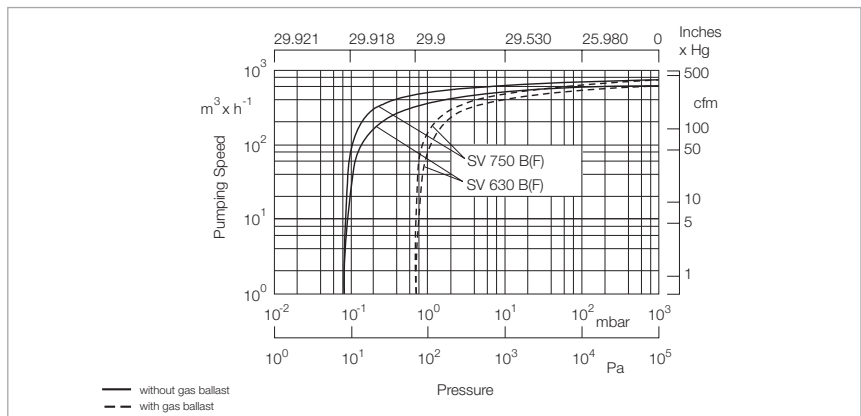

Pumping speed characteristics of the SOGEVAC SV 630 B(F) and 750 B(F) (60 Hz curves at the end of the chapter)

Technical Data

SOGEVAC SV 630 B

SOGEVAC SV 630 BF

SOGEVAC SV 750 B/BF

		50 Hz	60 Hz	50 Hz	60 Hz	50 Hz
Nominal speed ¹⁾	m ³ /h (cfm)	700 (412.0)	840 (494.4)	700 (412.0)	840 (494.4)	840 (494.4)
Pumping speed ¹⁾	m ³ /h (cfm)	640 (376.7)	755 (444.4)	640 (376.7)	755 (444.4)	755 (444.4)
Ultimate total pressure without gas ballast ¹⁾	mbar (Torr)	< 8 x 10 ⁻² (< 6 x 10 ⁻²)	< 8 x 10 ⁻² (< 6 x 10 ⁻²)	< 8 x 10 ⁻² (< 6 x 10 ⁻²)	< 8 x 10 ⁻² (< 6 x 10 ⁻²)	< 8 x 10 ⁻² (< 6 x 10 ⁻²)
Ultimate total pressure with one gas ballast valve ¹⁾	mbar (Torr)	≤ 0.7 (≤ 0.5)	≤ 0.7 (≤ 0.5)	≤ 0.7 (≤ 0.5)	≤ 0.7 (≤ 0.5)	≤ 0.7 (≤ 0.5)
Ultimate total pressure with two gas ballast valves ¹⁾	mbar (Torr)	≤ 2 (≤ 1.5)	≤ 2 (≤ 1.5)	≤ 2 (≤ 1.5)	≤ 2 (≤ 1.5)	≤ 2 (≤ 1.5)
Water vapor tolerance with 1 gas ballast ^{1), 2)}	mbar (Torr)	40.0 (30.0)	50.0 (37.5)	25.0 (18.8)	30.0 (22.5)	50.0 (37.5)
with 2 gas ballast valves ^{1), 2)}	mbar (Torr)	60.0 (45.0)	70.0 (52.5)	35.0 (26.3)	40.0 (30.0)	70.0 (52.5)
Max. perm. water vapor capacity with 1 gas ballast ^{1), 2)}	kg/h (qt/hr)	17.0 (18.0)	24.0 (25.4)	11.0 (11.6)	14.0 (14.8)	24.0 (25.4)
with 2 gas ballast valves ^{1), 2)}	kg/h (qt/hr)	26.0 (27.5)	34.0 (35.9)	15.0 (15.9)	19.0 (20.1)	34.0 (35.9)
Controlled anti-suck back valve 24 V DC		–	–	yes	yes	–
Oil filling min. / max.	l	20 / 23	20 / 23	20 / 23	20 / 23	20 / 23
Noise level (averaged) ³⁾	dB(A)	72	75	72	75	75
Admissible ambient temperature	°C (°F)	12 - 40 (54 -104)	12 - 40 (54 -104)	12 - 40 (54 -104)	12 - 40 (54 -104)	12 - 40 (54 -104)
Motor power	kW (hp)	15.0 (20.2)	18.5 (25.0)	15.0 (20.2)	18.5 (25.0)	18.5 (–)
Nominal speed pump	min ⁻¹ (rpm)	820 (820)	1000 (1000)	820 (820)	1000 (1000)	1000 (1000)
Type of protection / Isolation	IP / -	54 / F	54 / F	54 / F	54 / F	54 / F
Cooling		air	air	water	water	air / water
Thermostatic valve		no	no	yes	yes	no / yes
Temperature protection Pump		no	no	yes	yes	no / yes
Motor PTC		no	no	yes	yes	no / yes
Water quality	TH	–	–	4 to 8	4 to 8	–
Water pressure, min. / max.	bar (psig)	–	–	2/8 (29/114)	2/8 (29/114)	–
Materials (materials in contact with the gas)		Steel, cast iron, Aluminium, FPM (FKM), Glass, Polyamid 6.6, Filter material (Polymers, Paper), Epoxy resin & Glass fibre	Steel, cast iron, Aluminium, FPM (FKM), Glass, Polyamid 6.6, Filter material (Polymers, Paper), Epoxy resin & Glass fibre	Steel, cast iron, Aluminium, FPM (FKM), Glass, Polyamid 6.6, Filter material (Polymers, Paper), Epoxy resin & Glass fibre	Steel, cast iron, Aluminium, FPM (FKM), Glass, Polyamid 6.6, Filter material (Polymers, Paper), Epoxy resin & Glass fibre	Steel, cast iron, Aluminium, FPM (FKM), Glass, Polyamid 6.6, Filter material (Polymers, Paper), Epoxy resin & Glass fibre
Net weight (with oil filling)	kg (lbs)	730 (1611)	760 (1678)	730 (1611)	760 (1678)	750 (1656)
Dimensions (L x W x H)	mm (in.)	1510 x 909 x 740 (59.45 x 35.79 x 29.13)	1510 x 909 x 740 (59.45 x 35.79 x 29.13)	1566 x 638 x 909 (61.65 x 25.12 x 35.79)	1566 x 638 x 909 (61.65 x 25.12 x 35.79)	1510 x 909 x 740 (59.45 x 35.79 x 29.13)
Connection Intake	EUROPE / US	DN	DN 100 PN 10 / DN 100 ISO-K	DN 100 PN 10 / DN 100 ISO-K	DIN 160 Roots adapter 100 ISO-K	DN 100 PN 10 / DN 100 ISO-K
Exhaust	EUROPE / US	DN	Option ⁴⁾	Option ⁴⁾	100 ISO-K	Option

¹⁾ To DIN 28 400 and following numbers, with standard gas ballast

²⁾ Please ask Leybold for more information

³⁾ Operated at the ultimate pressure without gas ballast, free-field measurement at a distance of 1 m (3.5 ft)

⁴⁾ 77 mm exhaust with 4 x M10 holes on 145 mm circle.

Ordering Information

SV 630 B 50/60 Hz

SOGEVAC SV 630 BF 50/60 Hz

SV 750 B/BF 50 Hz

	Part No.	Part No.	Part No.
SOGEVAC SV 630 B with three-phase motor (NEMA) 400 V, 50 Hz and 230/460 V, 60 Hz w/o terminal board	960 865	-	-
380/400/415/690 V, 50 Hz and 440/460 V, 60 Hz	960 863	-	-
200 V, 50 Hz (JIS) and 200 V, 60 Hz	960 862	-	-
SOGEVAC SV 630 BF with three-phase motor (NEMA) 400 V, 50 Hz and 230/460 V, 60 Hz w/o terminal board	-	960 869	-
380/400/415/690 V, 50 Hz and 440/460 V, 60 Hz	-	960 867	-
200 V, 50 Hz (JIS) and 200 V, 60 Hz	-	960 866	-
SOGEVAC SV 750 B with three-phase motor 380/400/415/690 V, 50 Hz	-	-	960 875
SOGEVAC SV 750 BF with three-phase motor 380/400/415/690 V, 50 Hz	-	-	960 877
Other voltages/frequencies	upon request	upon request	upon request
Filling with special oil	upon request	upon request	upon request

Ordering Information

**SV 630 B
50/60 Hz**

**SOGEVAC
SV 630 BF
50/60 Hz**

**SV 750 B/BF
50 Hz**

	Part No.	Part No.	Part No.
Accessories			
Adapter for Roots pump RUVAC 1000 RUVAC 2000 RUVAC WH4400	971 432 340 971 432 350 971 43 WH4400	971 432 340 standard 971 43 WH4400	971 432 340 971 432 350 971 43 WH4400
Oil drain valve	711 30 114	standard	711 30 114
Gas ballast kit electromagnetic, 24 V DC	971 438 170	standard	971 438 170
Gas ballast, standard manual	standard	971 446 490	971 446 490
2nd gas ballast valve electromagnetic, 24 V DC manual	- 971 438 340	971 438 160 -	- 971 438 340
Exhaust filter monitoring gauge	951 94	951 94	951 94
Oil level check	971 425 760	971 425 760	425 760
Temperature switch	standard	standard	standard
Water cooling with thermostatic valve	upon request	standard	upon request
Intake kit DN 100 ISO-K	standard	971 430 550	standard
Exhaust filter overpressure switch	712 22 360	712 22 360	712 22 360
Oil filter bypass	712 36 390	712 36 390	712 36 390
Exhaust kit DN 100 PN 10 - 100 ISO-K	971 438 540	standard	971 438 540 for B version, standard on SV 750 BF
Spare Parts			
Oil filter, standard	EK 960 08	EK 960 08	EK 960 08
Exhaust filter AFE SV630/SV750B/SV300B (8 are required)	971 431 120	971 431 120	971 431 120
Intake filter element Paper Metal Activated charcoal Polyester	710 35 242 E 710 37 734 710 37 724 712 61 508	710 35 242 E 710 37 734 710 37 724 712 61 508	710 35 242 E 710 37 734 710 37 724 712 61 508
Seal kit FPM	971 437 310	971 437 310	971 437 310
Repair kit, complete	971 437 320	971 437 320	971 437 320
Generator kit	971 437 330	971 437 330	971 437 330
Maintenance kit	971 437 340	971 437 340	971 437 340

SOGEVAC SV 1200



SOGEVAC SV 1200

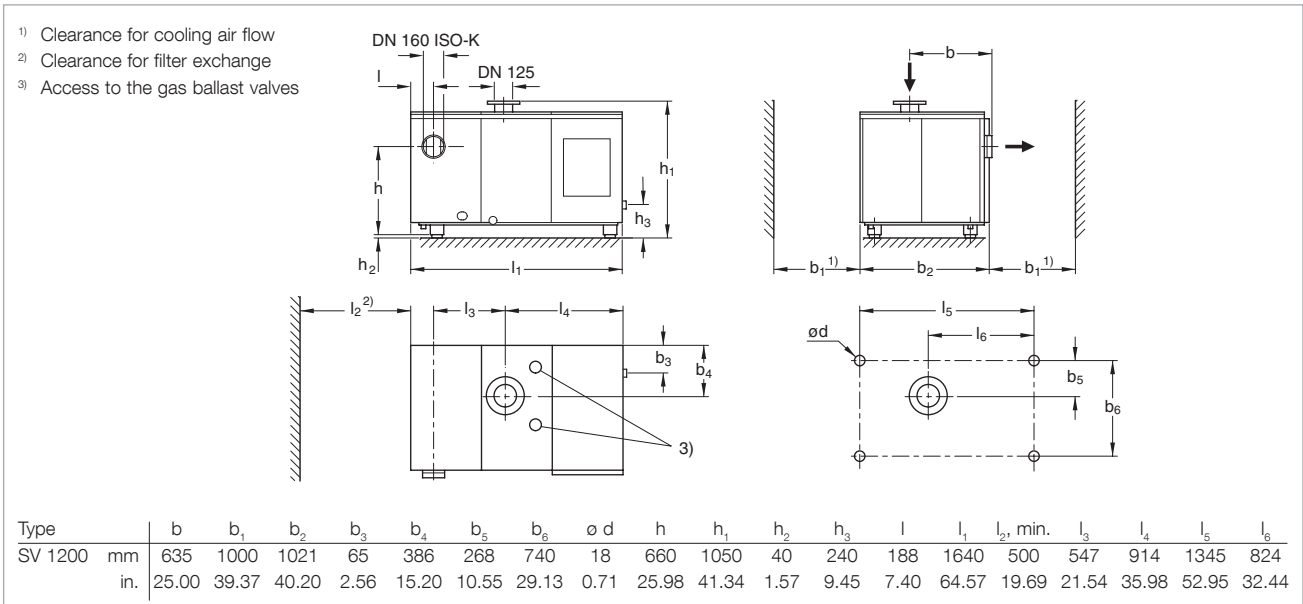

Dimensional drawing for the SOGEVAC SV 1200

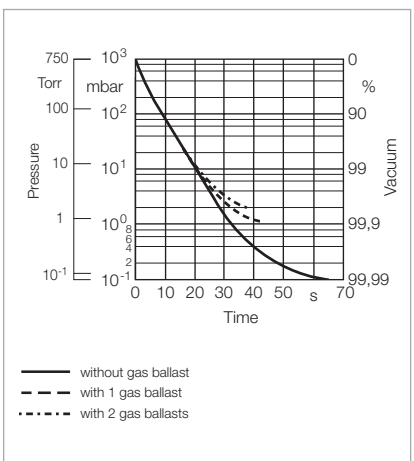

Pump-down characteristics of a 1000 l vessel at 50 Hz

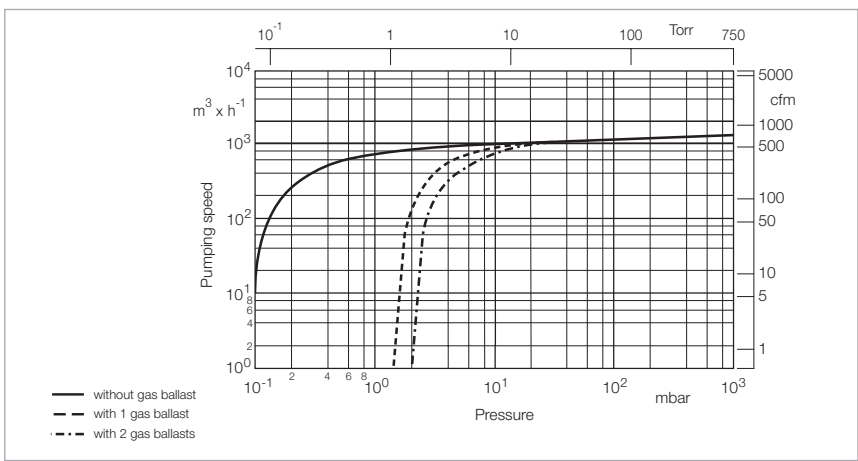

Pumping speed characteristics of the SOGEVAC SV 1200 at 50 and 60 Hz

Technical Data

SOGEVAC SV 1200

		50 Hz	60 Hz
Nominal speed ¹⁾	m ³ /h (cfm)	1150 (677)	1150 (677)
Pumping speed ¹⁾	m ³ /h (cfm)	1070 (630)	1070 (630)
Ultimate total pressure without gas ballast ¹⁾	mbar (Torr)	≤ 0.1 (≤ 0.08)	≤ 0.1 (≤ 0.08)
Ultimate total pressure with 1 standard gas ballast ¹⁾	mbar (Torr)	≤ 1.5 (≤ 1.1)	≤ 1.5 (≤ 1.1)
with 2 gas ballasts ²⁾	mbar (Torr)	≤ 2.0 (≤ 1.5)	≤ 2.0 (≤ 1.5)
Water vapor tolerance with 1 gas ballast	mbar (Torr)	20.0 (15.0)	20.0 (15.0)
with 2 gas ballasts	mbar (Torr)	40.0 (30.0)	40.0 (30.0)
Water vapor capacity with 1 gas ballast	kg/h (qt/hr)	12.5 (13.0)	12.5 (13.0)
with 2 gas ballasts	kg/h (qt/hr)	25.0 (26.0)	25.0 (26.0)
Oil capacity, min. / max.	l (qt)	60 (63) / 70 (74)	60 (63) / 70 (74)
Noise level ³⁾	dB(A)	75	75
Admissible ambient temperature	°C (°F)	12 to 40 (54 to 104)	12 to 40 (54 to 104)
Motor power	kW (hp)	22 (30)	22 (30)
Nominal motor speed / Pump rated rotational speed	min ⁻¹ (rpm)	1460 (1460) / 700 (700)	1750 (1750) / 700 (700)
Type of protection	IP	54-F	54-F/TEFC ⁴⁾
Weight (with oil filling)	kg (lbs)	1450 (3200)	1500 (3311)
Dimensions (L x W x H)	mm (in.)	1640 x 1021 x 1050 (64.57x 40.20 x 41.34)	1640 x 1021 x 1050 (64.57x 40.20 x 41.34)
Connection			
Intake	DN	125 PN 10	ASA 150 - 6" ⁵⁾
Exhaust	DN	160 ISO-K	ASA 150 - 6" ⁵⁾
Option ⁶⁾	DN	125 PN 10	–

¹⁾ To DIN 28 400 and following numbers

²⁾ With 2 gas ballasts

³⁾ Operated at the ultimate pressure without gas ballast, free-field measurement at a distance of 1 m (3.5 ft)

⁴⁾ CEI motor (Europe) 50/60 Hz has IP 54, NEMA motor (North and South America) has TEFC

⁵⁾ For NEMA pumps

⁶⁾ Please indicate when ordering a pump

Note: Further pump options upon request (for example, water cooled pumps)

Ordering Information

SOGEVAC SV 1200

50/60 Hz

	Part No.
SOGEVAC SV 1200 with three-phase motor, integrated gas ballast valves, air-cooled and over-temperature switch	
400 V, 50 Hz (CEI) ¹⁾	109 70
208 - 230/460 V, 60 Hz (NEMA)	950 70
Other voltages/frequencies ²⁾	upon request
Filling with special oil ²⁾	upon request
Accessories	
Water cooling with thermostatic valve ²⁾	upon request
Adaptor for Roots pump ^{2), 3)}	
RUVAC 2001	953 37
RUVAC 3001	953 38
RUVAC WH 4400/7000	953 3WH
Oil level monitor ^{2), 3)}	953 99
Exhaust filter monitoring switch electric ²⁾	712 22 360
Spare Parts	
Oil filter	EK 960 09
Oil filter bypass	712 36 390
Exhaust filter cartridge (14x required) AFE SV280/SV 300-SV1200	710 64 773
Set of gaskets NBR (standard)	971 96 681
Set of gaskets FPM (FKM)	712 36 060
Repair kit complete (50 Hz)	712 34 800
Pump module complete (50 Hz)	712 34 820

¹⁾ Junction box with six terminals for star/delta circuit

²⁾ Please indicate when ordering a pump

³⁾ Can be retrofitted

Note: Further pump options upon request

SOGEVAC SV 28 BI



SOGEVAC SV 28 BI

Advantages to the User

- 1 decade better ultimate pressure compared to SOGEVAC SV 25 B
- Integrated exhaust filter
- Integrated oil recovery system and anti suckback valve
- Extremely low noise level
- High reliability
- Variant concept
- Customer specific configurations
- High pumping speed stability at low pressure
- 2 oil casings (0.5 and 1.5 l) are available. The bigger oil volume allows longer oil life times

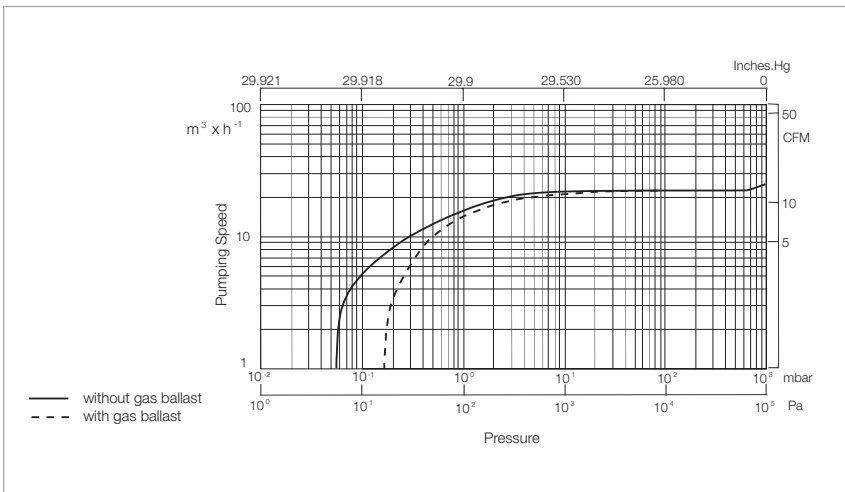

Pumping speed characteristics of the SOGEVAC SV 28 BI at 50 Hz
(60 Hz curves at the end of the chapter)

Typical Applications

- Mass spectrometry
- Lyophilisation
- Laboratory
- Refrigeration and air-conditioning
- Lamps and bulbs
- ... and more

Technical Data

SOGEVAC SV 28 BI

50 Hz

60 Hz

Nominal pumping speed	m ³ /h (cfm)	25 (14.8)	30 (17.8)
Pumping speed (according to PNEUROP)	m ³ /h (cfm)	23 (13.6)	27 (15.9)
Ultimate total pressure without gas ballast	mbar (Torr)	≤ 0.05 (≤ 0.04)	≤ 0.05 (≤ 0.04)
Ultimate total pressure with gas ballast	mbar (Torr)	≤ 0.5 (≤ 0.4)	≤ 0.5 (≤ 0.4)
Water vapor tolerable load with gas ballast	mbar (Torr)	10.0 (7.5)	10.0 (7.5)
Noise level (according to DIN 466535)			
3 ~ motor	dB(A)	54	57
1 ~ motor	dB(A)	57	60
Motor power			
3 ~ motor	kW (hp)	0.90 (1.2)	1.1 (1.5)
1 ~ motor	kW (hp)	0.75 (1.0)	0.9 (1.2)
Mains voltage and frequency			
3 ~ motor	V	see Ordering Information	see Ordering Information
1 ~ motor	V	see Ordering Information	see Ordering Information
Rated rotational speed	min ⁻¹ (rpm)	1500 (1500)	1800 (1800)
Type of protection and isolation class			
3 ~ motor	IP	55-F	55-F
1 ~ motor	IP	55-F	55-F
Leak rate	mbar x l/s	≤ 1 x 10 ⁻³	≤ 1 x 10 ⁻³
Oil capacity (depending on Part No.)	l (qt)	1.5 (1.59)	1.5 (1.59)
Net weight (with oil filling) dependent of oil casing and motor	kg (lbs)	34 (75) to 37 (82)	34 (75) to 37 (82)
Connections			
intake	DN	25 ISO-KF	25 ISO-KF
exhaust	DN	25 ISO-KF	25 ISO-KF

Ordering Information

SOGEVAC SV 28 BI 50/60 Hz

	Part No.
SOGEVAC SV 28 BI with wide range three-phase motor 170 - 253 / 294 - 440 V, 50 Hz and 170 - 292 / 294 - 506 V, 60 Hz with gas ballast, with 1.5 l oil casing	960 273
with wide range single-phase motor 180 - 264 V, 50/60 Hz with gas ballast, with 1.5 l oil casing	960 277
with single-phase motor (US and Japan) 100 V + 10%/- 15%, 50/60 Hz and 115 V + 10%/- 15%, 60 Hz with gas ballast, with 1.5 l oil casing	upon request
Other voltages/frequencies	upon request
Filling with special oil	upon request

Accessories

Exhaust filter cartridge	714 16 340
Spare Parts	
Repair kit	971 462 690
Set of seals FPM (FKM)	971 462 670
Generator kit	
three-phase	971 462 620
single-phase	971 462 630
Maintenance kit	971 462 810

For further accessories see
Chapter "Accessories TRIVAC"
in the Catalog Part
"Oil Sealed Vacuum Pumps TRIVAC"

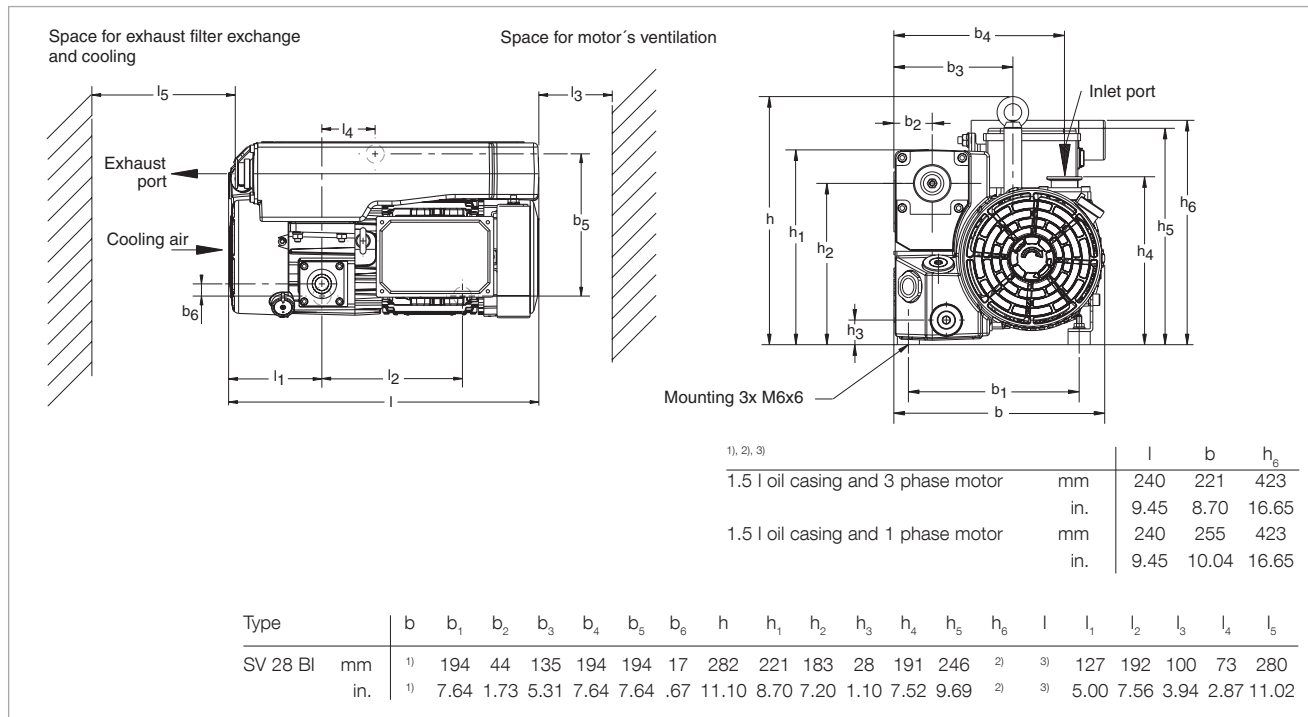

Dimensional drawing for the SOGEVAC SV 28 BI with standard single-phase motor, European version (dimensions for three-phase motor smaller)

SOGEVAC SV 40 BI



SOGEVAC SV 40 BI

Advantages to the User

- 1 decade better ultimate pressure compared to SOGEVAC SV 40 B
- Integrated exhaust filter
- Integrated oil recovery system and anti suckback valve
- Extremely low noise level
- High reliability
- Variant concept
- Customer specific configurations
- High pumping speed stability at low pressure

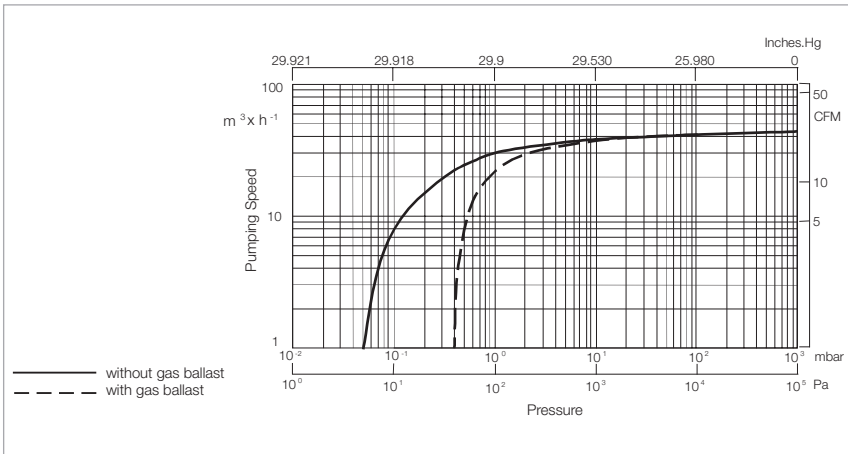

Pumping speed characteristics of the SOGEVAC SV 40 BI at 50 Hz (60 Hz curves at the end of the chapter)

Typical Applications

- Mass spectrometry
- Lyophilisation
- Refrigeration and air-conditioning
- Laboratory
- Lamps and bulbs
- ... and more

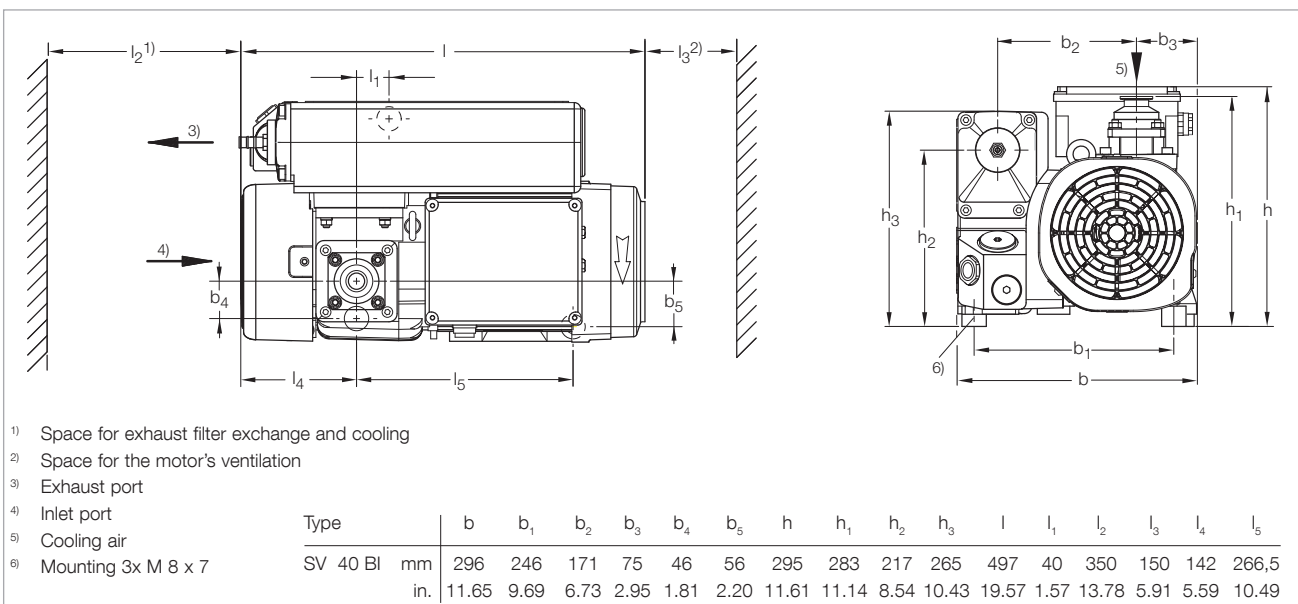

Dimensional drawing for the SOGEVAC SV 40 BI with standard single-phase motor, European version (dimensions for three-phase motor smaller)

Technical Data

SOGEVAC SV 40 BI

50 Hz

60 Hz

Nominal pumping speed	m ³ /h (cfm)	42 (24.8)	50 (29.5)
Pumping speed (according to PNEUROP)	m ³ /h (cfm)	40 (23.6)	48 (28.3)
Ultimate total pressure without gas ballast	mbar (Torr)	$\leq 5 \times 10^{-2}$ ($\leq 3.75 \times 10^{-2}$)	$\leq 5 \times 10^{-2}$ ($\leq 3.75 \times 10^{-2}$)
Ultimate total pressure with gas ballast	mbar (Torr)	≤ 0.5 (≤ 0.4)	≤ 0.5 (≤ 0.4)
Water vapor tolerable load with gas ballast	mbar (Torr)	0.28 (0.21)	0.34 (0.21)
Motor power	kW (hp)	1.1 (1.5)	1.3 (1.8)
Mains voltage and frequency	V	see Ordering Information	see Ordering Information
Rated rotational speed	min ⁻¹ (rpm)	1500 (1500)	1800 (1800)
Type of protection	IP	55-F	55-F
Leak rate	mbar x l/s	$\leq 1 \times 10^{-3}$	$\leq 1 \times 10^{-3}$
Oil capacity	l (qt)	1.0 (1.1)	1.0 (1.1)
Weight (with oil)	kg (lbs)	43 (94.9)	45 (99.3)
Connections			
intake	DN	40 KF	40 KF
exhaust	DN	40 KF	40 KF

Ordering Information

SOGEVAC SV 40 BI 50/60 Hz

	Part No.
SOGEVAC SV 40 BI	
with three-phase motor	
without gas ballast	
230/400 V, 50 Hz and 460 V, 60 Hz	960 330
with small gas ballast	
230/400 V, 50 Hz and 460 V, 60 Hz	960 331
Other voltages/frequencies or	
single-phase motors	upon request
Filling with special oil	upon request
Accessories	
Exhaust filter cartridge AFE SV40B I	971 471 470
Spare Parts	
Repair kit	971 443 150
Set of seals	971 427 640
Maintenance kit	971 427 660
Vacuum generator	
with gas ballast	971 443 160
without gas ballast	971 443 170

For further accessories
see Chapter "Accessories TRIVAC"
in the Section
"Oil Sealed Vacuum Pumps TRIVAC"

Pumps Prepared with PFPE for Use with Oxygen

Application

As soon as oxygen is being pumped at concentrations exceeding 20% (atmospheric air) the SOGEVAC pump needs to be prepared especially for such operation.

Safety Precautions

As standard, the pumps are equipped with FPM (FKM) seals and an oil filter bypass. Before assembly, all parts are degreased and the pumps are tested with PFPE lubricant (LVO 400). Thereafter the pumps are emptied and delivered without PFPE lubricant (LVO 400).

The pumps are supplied with special Operating Instructions (GA), Spare Parts List (ET) and include a CE declaration. This special information must be observed.

Due to the use of PFPE lubricant (LVO 400) and grease, also the maintenance schedule has been changed accordingly.

Only degreased accessories (filters and valves) and original spare parts from Leybold Vacuum must be used.

Product Selection

SOGEVAC pumps of the following sizes are available:

SV 16, SV 25, SV 65 B, SV 100 B, SV 200, SV 300 B, SV 630 B (F) and SV 750 B.

The use of PFPE lubricant (LVO 400) will also impair the attainable ultimate pressure depending on the size of the pump.

Local safety regulations (handling of O₂ and PFPE (LVO 400)) must be observed!

Advantages to the User

- High pumping speed down to ultimate pressure
- Operation of the pump at all pressures between 1000 mbar (750 Torr) and ultimate pressure is possible
- Integrated and effective separation of oil mist
- Compact design
- Air or water cooled
- Environment friendly (low noise and low heat radiation, low vibrations)
- Available in many different variants, motor voltages, ports etc.

Pump

Ultimate pressure (mbar (Torr))
without gas ballast with gas ballast

	Part No.		
SV 16 D	960184V2016, 960185V2016 960186V2016	1.0 (0.75)	2.5 (1.88)
SV 25 D	960211V2016 960215V2016	1.0 (0.75)	2.5 (1.88)
SV 65 B	960400V2016, 960401V2016, 960412V2016	1.0 (0.75)	2.5 (1.88)
SV 100 B	960500V2016, 960505V2016, 960512V2016	1.0 (0.75)	2.5 (1.88)
SV 200	1092616, 1092716, 9502716	0.5 (0.375)	1.5 (1.13)
SV 300 B	960702V2016, 960707V2016, 960717V2016	0.5 (0.38)	1.5 (1.13)
SV 630 B(F)	960863V3011	1.0 (0.75)	1.5 (1.13)
SV 750 B(F)	960877V3001	1.0 (0.75)	1.5 (1.13)

SOGEVAC SV 40 ATEX (Explosion Protected and Pressure Burst Resistant)

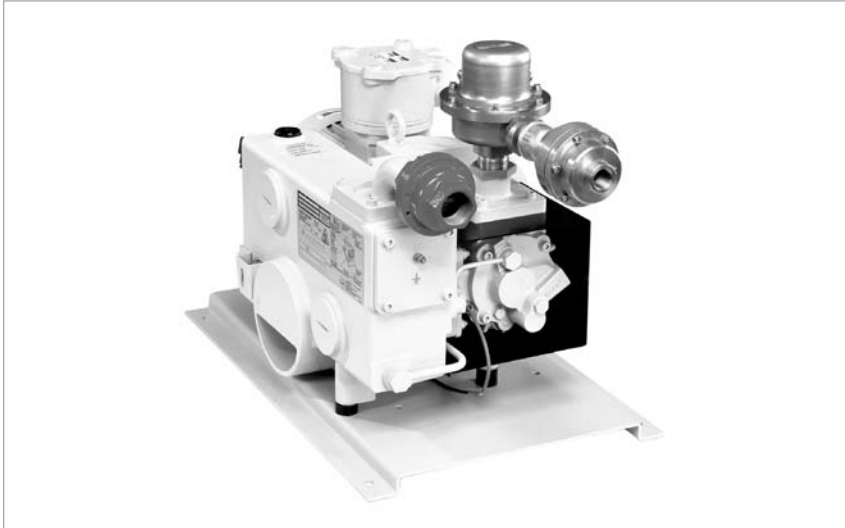

IIA version with MR 40 pressure regulator on the suction side and horizontal suction flanges

The SOGEVAC SV 40 ATEX Cat. 1 rotary vane vacuum pumps comply with the European Directive 2014/34/EU regarding "Equipment and protective systems for use in potentially explosive atmospheres".

Classification

- Equipment group: II
- Categories: 1G inside
2G outside
- Zone: 0 inside
1 outside
- Material group: IIB + H₂ or IIA
- Temperature classes:
 - IIB + H₂ at 50 Hz, T4
at 60 Hz, 160 °C
 - IIA at 50 and 60 Hz, T3

Applications

These pumps are suited for pumping solvents, for drying, filling applications including IIB + H₂ or IIA material groups.

Safety Characteristics

- In order to fulfill the requirements of the safety regulations, the SOGEVAC SV 40 ATEX Cat. 1 pumps are equipped with:
- 1 flame arrester on their suction and exhaust sides
 - 1 pressure transmitter controlling the pressure in the oil casing
 - 1 temperature sensor controlling the pump temperature
 - 1 inlet gas temperature monitoring on the inlet side of the pump (for IIB + H₂ versions only).

Furthermore, these pumps have an explosion-proof design.

Advantages to the User

- High pumping speed down to ultimate pressure
- High vapor pumping capability
- Running possible at any pressure, from 1000 mbar (750 Torr) to ultimate pressure
- Integrated and efficient oil mist separation
- Compact design
- Air cooled
- Environment-friendliness (low noise level, no cooling water, low vibration operation)
- Many different designs available

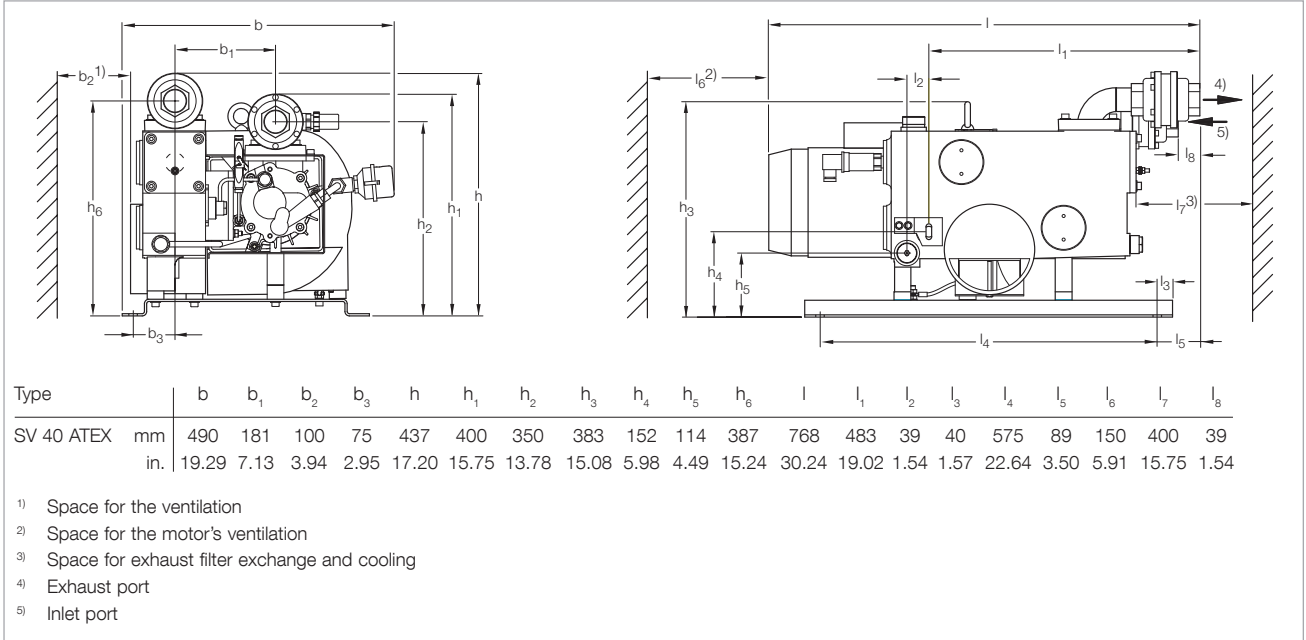

Dimensional drawing for the SOGEVAC SV 40 ATEX with standard motor, European version

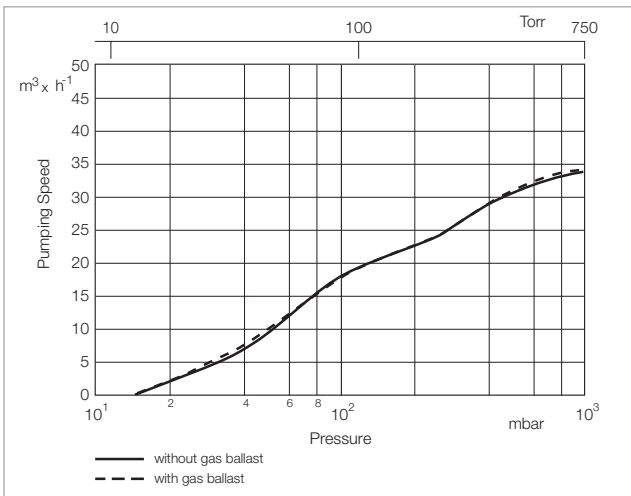

Pumping speed characteristics of the SOGEVAC SV 40 ATEX at 50 Hz for gases of the material group IIB + H₂ (60 Hz curves at the end of the chapter)

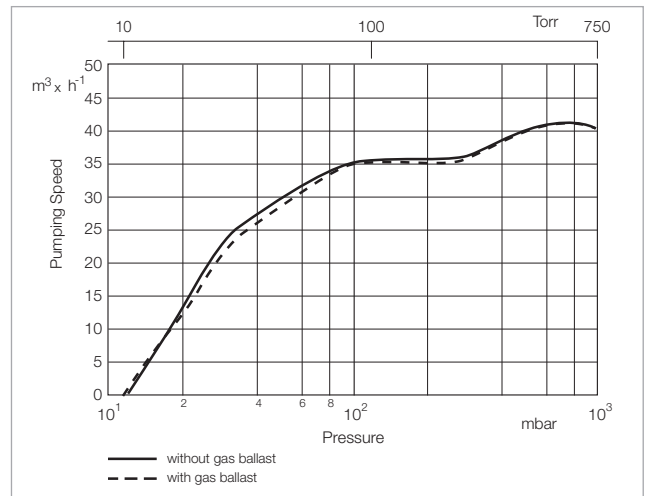

Pumping speed characteristics of the SOGEVAC SV 40 ATEX at 50 Hz for gases of the material group IIA (60 Hz curves at the end of the chapter)







Technical Data

SOGEVAC SV 40 ATEX

		50 Hz	60 Hz
Nominal pumping speed	m ³ /h (cfm)	46.0 (27.1)	55.2 (32.5)
Pumping speed (according to PNEUROF)			
IIB + H ₂	m ³ /h (cfm)	26 (15.3)	29 (17.1)
IIA	m ³ /h (cfm)	35 (20.6)	42 (24.7)
Ultimate total pressure without gas ballast			
IIA / IIB + H ₂	mbar (Torr)	0.8 (0.6)	0.8 (0.6)
Ultimate total pressure with gas ballast			
IIA / IIB + H ₂	mbar (Torr)	1.5 (1.1)	1.5 (1.1)
Noise level (according to DIN 45635)	dB(A)	63	68
Water vapor tolerable load with gas ballast	mbar (Torr)	0.30 (0.23)	0.30 (0.23)
Motor power	kW (hp)	1.5 (2.0)	1.8 (2.4)
Rated rotational speed	min ⁻¹ (rpm)	1500 (1500)	1800 (1800)
Standard voltage	V	230/400 (± 10%)	460 (± 10%)
Type of protection	IP	55-F	55-F
Leak rate	mbar x l/s	≤ 1 x 10 ⁻³	≤ 1 x 10 ⁻³
Type of oil		LVO 210 (IIB + H ₂) or LVO 200 (IIA)	LVO 210 (IIB + H ₂) or LVO 200 (IIA)
Oil capacity, approx.	l (qt)	2 (2.1)	2 (2.1)
Materials (materials in contact with the gas)		Steel, cast iron, Aluminium, Bronze, FPM (FKM), Glass, Polyamid 6.6, Filter material (Polymers, Paper), epoxy resin & glass fibre	Steel, cast iron, Aluminium, Bronze, FPM (FKM), Glass, Polyamid 6.6, Filter material (Polymers, Paper), epoxy resin & glass fibre
Weight (with oil filling)	kg (lbs)	110 (243)	110 (243)
Connections			
intake			
IIB + H ₂	G	1 1/4"	1 1/4"
IIA	G	3/4"	3/4"
exhaust	G	1 1/4"	1 1/4"
Maximum gas inlet temperature	°C (°F)	40 (104)	40 (104)

Ordering Information

SOGEVAC SV 40 ATEX

	50 Hz	60 Hz
	Part No.	Part No.
SOGEVAC SV 40 ATEX LA IIB + H ₂ in accordance with 2014/34/EU [ II 1/2 G IIB + H ₂ T4 (+5 °C < t _a < 40 °C) EC Type Examination Certificate: PTB04ATEX4013X] with permanent gas ballast	960 345	-
SOGEVAC SV 40 ATEX LA IIB + H ₂ in accordance with 2014/34/EU [ II 1/2 G IIB + H ₂ 160 °C (+5 °C < t _a < 40 °C) EC Type Examination Certificate: PTB04ATEX4013X] without gas ballast	-	960 349 V 3060
SOGEVAC SV 40 ATEX IIB + H ₂ in accordance with 2014/34/EU [ II 1/2 G IIB + H ₂ T4 (+5 °C < t _a < 40 °C) EC Type Examination Certificate: PTB04ATEX4013X] without gas ballast	960 346	-
SOGEVAC SV 40 ATEX IIB + H ₂ in accordance with 2014/34/EU [ II 1/2 G IIB + H ₂ 160 °C (+5 °C < t _a < 40 °C) EC Type Examination Certificate: PTB04ATEX4013X] without gas ballast	-	960 346 V 3060
SOGEVAC SV 40 ATEX IIB + H ₂ in accordance with 2014/34/EU [ II 1/2 G IIB + H ₂ T4 (+5 °C < t _a < 40 °C) EC Type Examination Certificate: PTB04ATEX4013X] with gas ballast and MR 40 pressure regulator	960 343	-
SOGEVAC SV 40 ATEX IIA in accordance with 2014/34/EU [ II 1(i)/ 2(o) G IIA T3 (+5 °C < t _a < 40 °C) EC Type Examination Certificate: PTB04ATEX4011X] without gas ballast	960 344	960 349 V 3060
SOGEVAC SV 40 ATEX IIA in accordance with 2014/34/EU [ II 1(i)/ 2(o) G IIA T3 (+5 °C < t _a < 40 °C) EC Type Examination Certificate: PTB04ATEX4011X] without gas ballast, with MR 40 pressure regulator	960 342	-
Accessories	upon request	upon request
Spare Parts	upon request	upon request

For all enquiries and orders relating to category 1 and 2 ATEX products please exclusively use our ATEX questionnaire. You can find this questionnaire at the end of the full-line catalog together with the fax forms or on the Internet under "www.leybold.com" under Download Documents in the area Documentation.

ATEX Category 2 Pumps

Application

As soon as gases capable of exploding are being pumped or if such gases are present in the vicinity, then the customer must perform a hazard analysis. In Europe, the ATEX Directives 2014/34/EU need to be observed in this regard. For equipment in Zone 1, ATEX Category 3 SOGEVAC pumps are available.

Classification

As in the table below.

Safety Precautions

As standard, the pumps are equipped with FPM (FKM) seals, oil filter bypass and oil LEYBONOL LVO 210. Special ATEX exhaust filters, coupling components, motors, floats and final inspections are used, respectively performed. A DN 16 ISO-KF connection for the gas ballast is supplied.

All pumps are equipped with Pt100 temperature, oil level and oil casing pressure sensors. The motors are equipped with PTC thermistors.

SOGEVAC pumps of the following sizes are available:

SV 40 B, SV 65 B, SV 100 B, SV 200, SV 300 B, SV 630 B and SV 750 B

The pumps are supplied with special Operating Instructions (GA), Spare Parts List (ET) and include a CE declaration. This special information must be observed.

LV Restrictions apply for Service and Repairs: please consult us.

Only special accessories (filters, valves, taps) and original spare parts from Leybold must be used.

Advantages to be User

- High pumping speed down to ultimate pressure
- Operation of the pump at all pressures between 1000 mbar (750 Torr) and ultimate pressure is possible
- Integrated and effective separation of oil mist
- Compact design
- Air or water cooled
- Different gas ballast variants: without, manual and permanent upon request
- Available in many different variants, motor voltages, ports etc.

The pumping speed curves for ATEX Category 2 pumps are the same as for non ATEX standard SOGEVAC pumps.

Pump

Ultimate pressure (mbar (Torr))
without gas ballast with gas ballast

	Part No.		
SV 40 B air cooled Ex II (j) 2G b IIB + H2 T3 / (o) 2G IIC T4 (10 °C < T _a > 40 °C) X	960305A22	0.5 (0.38)	1.5 (1.13)
SV 65 B air cooled Ex II (j) 2G b IIB + H2 T3 / (o) 2G IIC T4 (10 °C < T _a > 40 °C) X	960405A22	0.5 (0.38)	1.5 (1.13)
SV 100 B air cooled Ex II (j) 2G b IIB + H2 T3 / (o) 2G IIC T4 (10 °C < T _a > 40 °C) X	960505A22	0.5 (0.38)	1.5 (1.13)
SV 120 B air cooled Ex II (j) 2G b IIB + H2 T3 / (o) 2G IIC T4 (10 °C < T _a > 40 °C) X	upon request	0.5 (0.38)	1.5 (1.13)
SV 200 air cooled Ex II (j) 2G b IIB + H2 T3 / (o) 2G IIC T3 (10 °C < T _a > 40 °C) X	10927A22	0.15 (1.13)	0.7 (0.53)
SV 200 water cooled Ex II (j) 2G b IIB + H2 T3 / (o) 2G IIC T3 (10 °C < T _a > 40 °C) X	1092702A22	0.15 (1.13)	0.7 (0.53)
SV 300 B air cooled Ex II (j) 2G b IIB + H2 T3 / (o) 2G IIC T3 (10 °C < T _a > 40 °C) X	960702A22	0.15 (1.13)	0.7 (0.53)
SV 630 B air cooled Ex II (j) 2G b IIB + H2 T3 / (o) 3GD IIC T3 (150 °C) (10 < T _a > 40 °C) X	upon request	0.15 (1.13)	0.7 (0.53)
SV 630 BF water cooled Ex II (j) 2G b IIB + H2 T3 / (o) 3GD IIC T3 (150 °C) (10 < T _a > 40 °C) X	upon request	0.15 (1.13)	0.7 (0.53)
SV 750 B air cooled Ex II (j) 2G b IIB + H2 T3 / (o) 3GD IIC T3 (150 °C) (10 < T _a > 40 °C) X	upon request	0.15 (1.13)	0.7 (0.53)
SV 750 BF water cooled Ex II (j) 2G b IIB + H2 T3 / (o) 3GD IIC T3 (150 °C) (10 < T _a > 40 °C) X	upon request	0.15 (1.13)	0.7 (0.53)

ATEX outside Dust: upon request. For SV 630 B(F): as on existing Cat 3 pumps.

SV 630 B(F) and SV 750 B(F) are ATEX Cat 3 only outside.

Gas ballast connection: with DN 16 ISO-KF as on Cat 3 pumps. Manual gas ballast is standard.

SV 40 B to SV 120 B with manual gas ballast are T3 inside. Pumps with permanent gas ballast are T4 inside.

Big gas ballast or no gas ballast available upon request.

For all enquiries and orders relating to category 1 and 2 ATEX products please exclusively use our ATEX questionnaire.

You can find this questionnaire at the end of the full-line catalog together with the fax forms or on the Internet under "www.leybold.com" under Download Documents in the area Documentation.

ATEX Category 3 Pumps

Application

As soon as gases capable of exploding are being pumped or if such gases are present in the vicinity, then the customer must perform a hazard analysis. In Europe, the ATEX Directives 2014/34/EU need to be observed in this regard. For equipment in Zone 2, ATEX Category 3 SOGEVAC pumps are available.

Classification

As in the table below.

Safety Precautions

As standard, the pumps are equipped with FPM (FKM) seals, oil filter bypass and oil LEYBONOL LVO 210. Special ATEX exhaust filters, coupling components, motors, floats and final inspections are used, respectively performed. A DN 16 ISO-KF connection for the gas ballast is supplied.

All pumps are equipped with Pt100 temperature, oil level and oil casing pressure sensors. The motors are equipped with PTC thermistors.

SOGEVAC pumps of the following sizes are available:

SV 40 B, SV 65 B, SV 100 B, SV 200, SV 300 B, SV 630 B and SV 750 B.

The pumps are supplied with special Operating Instructions (GA), Spare Parts List (ET) and include a CE declaration. This special information must be observed.

Only special accessories (filters, valves, taps) and original spare parts from Leybold must be used.

Advantages to be User

- High pumping speed down to ultimate pressure
- Continuous operation of the pump at all pressures between 1000 mbar (750 Torr) and ultimate pressure is possible
- Integrated and effective separation of oil mist
- Compact design
- Air or water cooled
- Environment friendly (low noise and low heat radiation, low vibrations)
- Available in many different variants, motor voltages, ports etc

The pumping speed curves for ATEX Category 3 pumps are the same as for non ATEX standard SOGEVAC pumps.

Pump

Ultimate pressure (mbar (Torr))
without gas ballast with gas ballast

	Part No.		
SV 40 B air cooled Ex II (j) 3G IIC T3 / (o) 3 GD IIC T3 (150 °C)(10 < T _a < 40 °C) X	960305A33	0.5 (0.38)	1.5 (1.13)
SV 65 B air cooled Ex II (j) 3 G IIC T3 / (o) 3 GD IIC T3 (150 °C)(10 < T _a < 40 °C) X	960405A33	0.5 (0.38)	1.5 (1.13)
SV 100 B air cooled Ex II (j) 3 G IIC T3 / (o) 3 GD IIC T3 (150 °C)(10 < T _a < 40 °C) X	960505A33	0.5 (0.38)	1.5 (1.13)
SV 200 air cooled Ex II (j) 3 G IIC T3 / (o) 3 GD IIC T3 (150 °C)(10 < T _a < 40 °C) X	10927A33	0.15 (1.13)	0.7 (0.53)
SV 300 B air cooled Ex II (j) 3 G IIC T3 / (o) 3 GD IIC T3 (150 °C)(10 < T _a < 40 °C) X	960702A33	0.15 (1.13)	0.7 (0.53)
SV 630 air cooled Ex II (j) 3 G IIC T3 / (o) 3 GD IIC T3 (150 °C)(10 < T _a < 40 °C) X	960863A33	0.15 (1.13)	0.7 (0.53)
SV 630 BF water cooled Ex II (j) 3 G IIC T3 / (o) 3 GD IIC T3 (150 °C)(10 < T _a < 40 °C) X	960867A33	0.15 (1.13)	0.7 (0.53)
SV 750 B air cooled Ex II (j) 3 G IIC T3 / (o) 3 GD IIC T3 (150 °C)(10 < T _a < 40 °C) X	upon request	0.15 (1.13)	0.7 (0.53)
SV 750 BF water cooled Ex II (j) 3 G IIC T3 / (o) 3 GD IIC T3 (150 °C)(10 < T _a < 40 °C) X	upon request	0.15 (1.13)	0.7 (0.53)

For all enquiries and orders relating to category 1 and 2 ATEX products please exclusively use our ATEX questionnaire. You can find this questionnaire at the end of the full-line catalog together with the fax forms or on the Internet under "www.leybold.com" under Download Documents in the area Documentation.

Accessories

Double Inlet Filter and Roots Adapter TwinFilter 500 for SOGEVAC SV 470 B(F) and SV 570 B(F)



Double inlet filter and Roots adapter TwinFilter 500

To avoid dust particles in your process use the new double inlet filter and Roots adapter TwinFilter 500.

The TwinFilter replaces the otherwise needed Roots pump adapter to adapt a Roots vacuum pump. The Roots pump can be fitted directly on to the TwinFilter.

Typical Applications

- Protects the pump against dust and particles
- Compact forevacuum pump combination

Advantages to the User

- No external frame required: costs and space savings
- Very compact combinations: space savings yet roughing pump protection

- Allows to have 2 different protection filters in series: more efficient filtration and longer filter life time
- No elbows, bellows, adapters required for filter mounting: cost savings

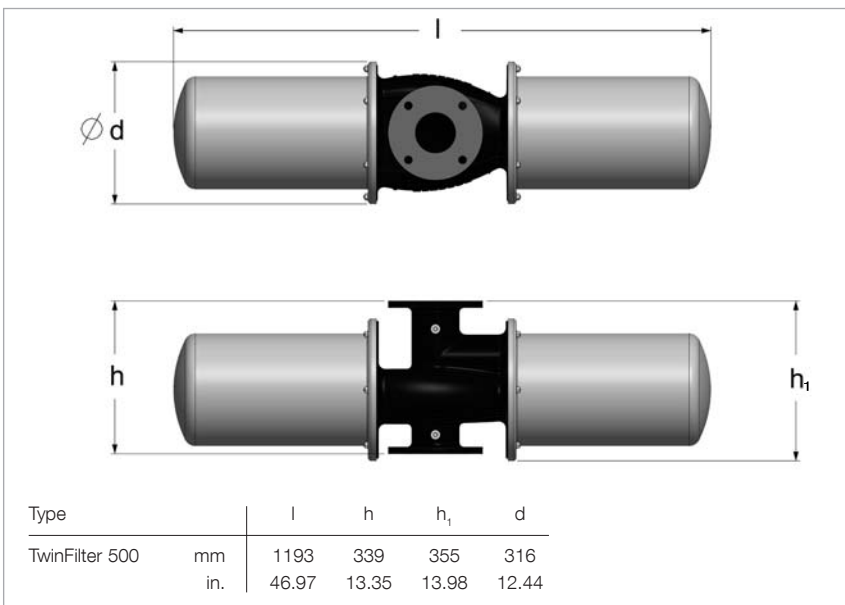

Dimensional drawing for the double inlet filter and Roots adapter TwinFilter 500

Adapter connection options

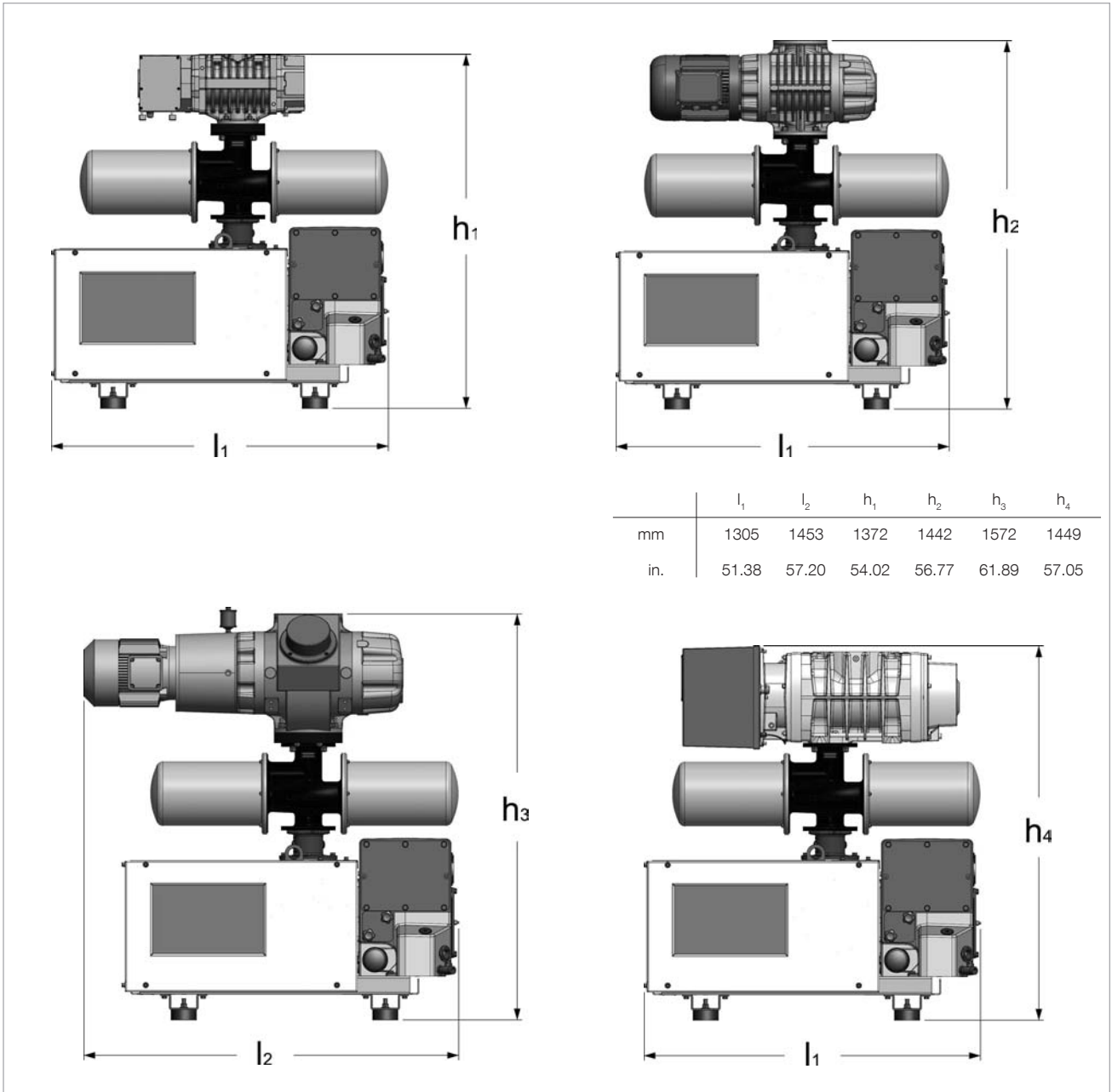

Ways in which to mount the Roots vacuum pump on the SOGEVAC SV 470 B(F) or SV 570 B(F)

Top left with RUVAC WH 700/702, top right with RUVAC WA(U)/WS(U) 1001,
bottom left with RUVAC WA(U) 2001, bottom right with RUVAC WH(U) 2500

Gas flow

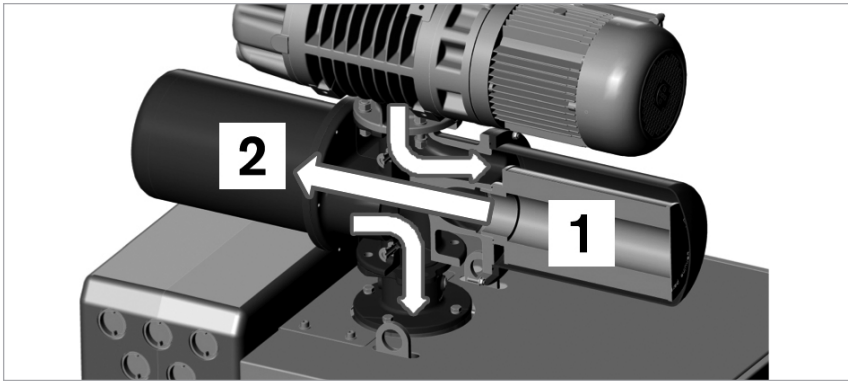

The gas passes through the filter (1), then through the filter (2) and then enters the roughing pump.

Gas flow

Selection of the filter cartridges

Filter type					
	Paper 2 mm	Polyester 2 µm	Polyester 25 µm	Metal 0,09 mm (0.004 in.)	Activated charcoal
Applicationen					
Dry processes with dust, powders, chips etc.)	2		1		
Wet (vapor) processes with dust, powders, chips etc.)		2	1		
Heavy particles, plastics, glass, packaging materials, food stuff, etc.		2		1	
Vapors of high molecular weight (solvent, resin and acid vapors, alkaline solutions etc.)		2			1

1= Filter No. 1 in the diagram "Gas flow"
2= Filter No. 2 in the diagram "Gas flow"

Technical Data

Double Inlet Filter TwinFilter 500

Double Inlet Filter and Roots Adapter TwinFilter 500	Paper Cartridge	Polyester Filter Cartridge	Polyester Filter Cartridge	Metal Cartridge	Active Charcoal Cartridge
Particle size / mesh	2 µm	2 µm	25 µm	0.09 mm (0.004 in.)	
Pumping speed ¹⁾ loss by new filters (approx.)					
100 mbar (75.0 Torr)	< 1%	< 1%	< 1%	< 1%	< 1%
10 mbar (7.5 Torr)	< 1%	< 1%	< 1%	< 1%	< 7%
1 mbar (0.75 Torr)	< 13%	< 6%	< 4%	< 3%	< 33%
Efficiency for					
2 µm particle	98%	98%	–	–	–
5 µm particle	99%	99%	–	–	–
Weight					
Net max.	kg (lbs)	82 (181)	82 (181)	82 (181)	82 (181)
Cover	kg (lbs)	< 10 (< 22)	< 10 (< 22)	< 10 (< 22)	< 10 (< 22)
Filter	kg (lbs)	< 10 (< 22)	< 10 (< 22)	< 10 (< 22)	< 10 (< 22)
Material		Cast iron, steel, filter material	Cast iron, steel, filter material	Cast iron, steel, filter material	Cast iron, steel, filter material

¹⁾ Pumping speed loss of each filter adds up for the total loss

Ordering Information

Double Inlet Filter TwinFilter 500

Double Inlet Filter and Roots Adapter TwinFilter 500	Paper Cartridge 2 µm	Polyester Filter Cartridge 2 µm	Polyester Filter Cartridge 25 µm	Metal Cartridge 0.09 mm (0.004 in.)	Active Charcoal Cartridge
For fitting to SOGEVAC	SV 470 B(F) / SV 570 B(F)	SV 470 B(F) / SV 570 B(F)	SV 470 B(F) / SV 570 B(F)	SV 470 B(F) / SV 570 B(F)	SV 470 B(F) / SV 570 B(F)
Part No. 9516248PAPO with paper cartridge and polyester filter cartridge 2 µm	X	-	X	-	-
Part No. 9516248PP with polyester filter cartridge 2 µm and 25 µm	-	X	X	-	-
Part No. 9516248MAPO with polyester filter cartridge 2 µm and metal cartridge	-	X	-	X	-
Part No. 9516248CAPO with polyester filter cartridge 2 µm and active charcoal cartridge	-	X	-	-	X
Part No. 9516248V without filter	X	X	X	X	X
Spare inlet filter Part No. EK95162PA	X	-	-	-	-
Spare inlet filter Part No. EK95162PO2	-	X	-	-	-
Spare inlet filter Part No. EK95162PO25	-	-	X	-	-
Spare inlet filter Part No. EK95162MA	-	-	-	X	-
Spare inlet filter Part No. EK95162CA	-	-	-	-	X

Roots adapter

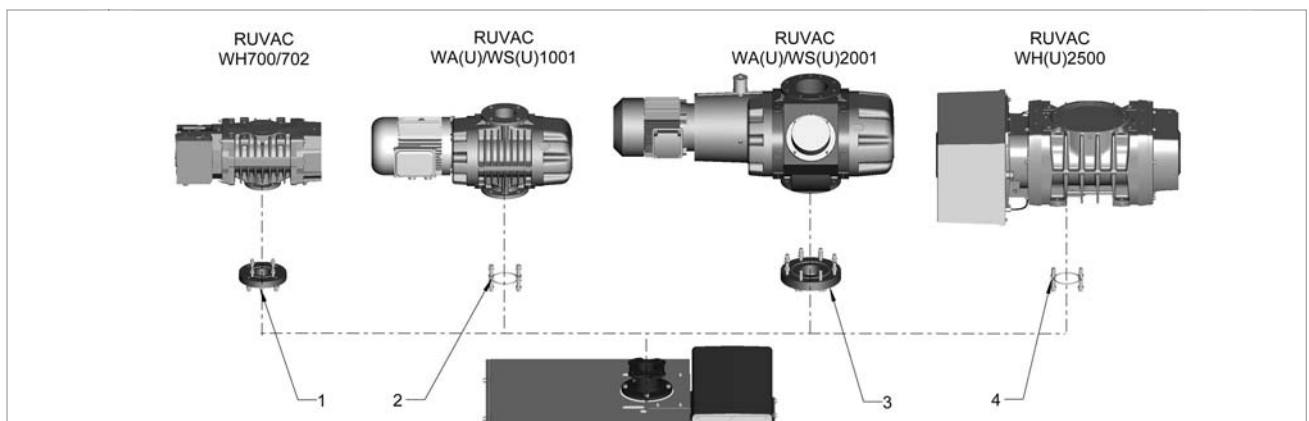

Roots adapter connections

Ordering Information

Roots adapter

	Part No.
Adapter for Roots vacuum pump	
RUVAC WH 700/702	9516241V
RUVAC WA(U)/WS(U) 1001	9516242V
RUVAC WA(U)/WS(U) 2001	9516243V
RUVAC WH(U) 2500	9516244V

Dust Filters (Suction Side)



SOGEVAC SV 40 with connected F 40 dust filter and different types of filter cartridges

The filters consist of a steel housing and a lid with three quick locking clips

Advantages to the User

- Same housing for different cartridges
- High separation capacity
- Quickly exchangeable cartridge

Paper Filter Cartridge (Standard)

- Separates particles down to 5 μm (Dry process: dust, powders, chips etc.)

Polyester Filter Cartridge

- Separation of particles down to 5 μm (Moist process: dust, powders, chips etc.)

Type		ø A	ø B	C	D	ø E	F	Weight (kg (lbs))
F 16-25	mm	G 1/2"	G 1/2"	54	104	100	70	1
	in.	G 1/2"	G 1/2"	2.13	4.09	3.94	2.76	2.2
F 40	mm	G 1 1/4"	G 1 1/4"	74	115	135	75	1.5
	in.	G 1 1/4"	G 1 1/4"	2.91	4.53	5.31	2.95	3.31
F 65-100	mm	G 1 1/4"	G 1 1/4"	98	172	172	130	2
	in.	G 1 1/4"	G 1 1/4"	3.86	6.77	6.77	5.12	4.4
F 200-300	mm	G 2"	G 2"	118	287	200	230	4.5
	in.	G 2"	G 2"	4.65	11.3	7.87	9.06	9.9
F 200-300	mm	63 ISO-K	63 ISO-K	160	357	258	250	15
	in.	63 ISO-K	63 ISO-K	6.3	14.06	10.16	9.84	33.1
F 630	mm	DN 100 PN 10	DN 100 PN 10	220	358	340	250	33
	in.	DN 100 PN 10	DN 100 PN 10	8.66	14.09	13.39	9.84	72.8
F 630	mm	100 ISO-K	100 ISO-K	220	358	340	250	32
	in.	100 ISO-K	100 ISO-K	8.66	14.09	13.39	9.84	70.6
F 1200	mm	DN 125 PN 10	DN 125 PN 10	225	498	340	250	44
	in.	DN 125 PN 10	DN 125 PN 10	8.86	19.61	13.39	9.84	1.73

Dimensional drawing for the dust filters F 16-25 to F 1200

Metal Filter Cartridge

- 0.08 mm (0.003 in.) mesh
- Collects solid particles down to 0.08 mm (0.003 in.) (plastics, paper, packaging materials, foodstuffs)

Activated Charcoal Cartridge

- Absorbs vapors of high molecular weight (solvent and acid vapors, alkaline solutions etc.)

Technical Notes

We recommend installing the filters horizontally on a 90° bend. This will prevent separated particles from falling into the intake line when disassembling the filter.

When using an activated charcoal filter it is recommended to also install a paper cartridge filter between the pump and the activated charcoal.

Technical Data

Dust Filter

Dust Filter	Paper Cartridge	Polyester Filter Cartridge	Metal Cartridge	Activated Charcoal Cartridge
Pumping speed reduction through a clean filter	2%	2%	1%	2%
Efficiency for 5 µm particles	98%	98%	–	–

Ordering Information

Dust Filter

Dust Filter	Part No.	Part No.	Part No.	Part No.
Dust Filter	Paper Cartridge	Polyester Filter Cartridge	Metal Cartridge	Activated charcoal Cartridge
F 16-25 for pumps from 10 to 25 m³/h (G 1/2")	951 50	711 27 094	711 27 093	711 27 092
Spare cartridge for F 16-25	710 40 760	712 61 288	E 710 65 813	E 710 65 713
F 40 for SV 40 B (G 1 1/4")	951 55	711 27 104	711 27 103	711 27 102
Spare cartridge for F 40	710 46 118	712 61 298	710 49 083	710 49 103
F 65-100 for SV 65 B, SV 100 B (G 1 1/4")	951 60	711 27 114	711 27 113	711 27 112
Spare cartridge for F 65-100	712 13 283	712 61 308	E 712 13 324	E 712 13 304
F 200-300 for SV 200, SV 300 B (G 2")	951 65	711 27 124	711 27 123	711 27 122
F 200-300 for SV 200, SV 300 B (DN 63 ISO-K)	951 68	711 27 127	711 27 126	711 27 125
Spare cartridge for F 200-300 (G 2" or DN 63 ISO-K)	712 13 293	712 61 318	712 13 334	E 712 13 314
F 630 for SV 630 (B/F), SV 750 (B/F) (DN 100 PN 10)	951 71	711 27 164	711 27 163	711 27 162
F 630 for SV 630 (B/F), SV 750 (B/F) (DN 100 ISO-K)	951 72	711 27 168	711 27 167	711 27 166
Spare cartridge for F 630 (DN 100 PN 10 or DN 100 ISO-K)	710 35 242	712 61 508	E 710 37 734	710 37 724
F 1200 for SV 1200 (DN 125 PN 10)	951 75	711 27 144	711 27 143	711 27 142
Spare cartridge for F 1200 (2x required)	710 35 242	712 61 508	E 710 37 734	710 37 724
Spare Parts				
Set of gaskets for F 16-25	NBR (Buna N)	714 10 820	714 10 820	714 10 820
Set of gaskets for F 40	NBR (Buna N)	714 10 830	714 10 830	714 10 830
Set of gaskets for F 65-100	NBR (Buna N)	714 10 840	714 10 840	714 10 840
Set of gaskets for F 200-300	NBR (Buna N)	714 10 850	714 10 850	714 10 850
O-ring gasket for F 630 / F 1200	NBR (Buna N)	712 41 032	712 41 032	712 41 032

Only available for purchase in North and South America

Dust Filters F (Suction Side)



SOGEVAC SV 40 with connected F-100 dust filter and different types of filter cartridges

High efficiency F filters are recommended for use at the inlet of SOGEVAC rotary vane vacuum pumps for protection against process contaminants, e.g., fiberglass particles, plastic dusts, resins and food-processing by-products. The filters are available with easily replaceable cartridge elements for particle filtration of dusts and particulates down to one microns, or activated carbon elements for the adsorption of chemical vapor.

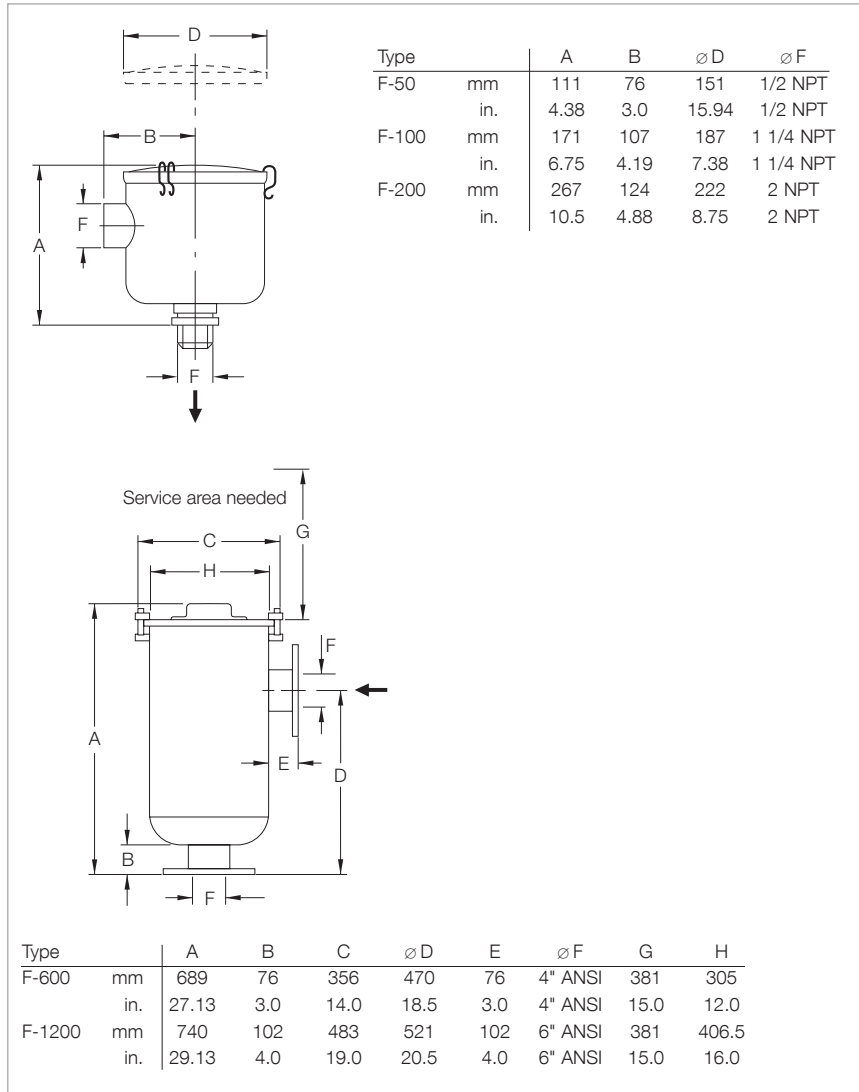

Dimensional drawings for the dust filters F 50 to F 200 (top) and F 600 to F 1200 (bottom)

Technical Data

Dust Filter

Dust Filter	Polyester Filter Cartridge	Metal Cartridge	Paper Cartridge	Activated Charcoal Cartridge
New cartridge pumping speed reduction	2%	1%	2%	2%
Efficiency for 1 µm particulates	98%	–	99%	–
Filter for SV 16 (B), SV 25 (B), UV 25	–	–	F-50	–
Filter for SV 40 (B), SV 65 (B), SV 100 (B)	–	F-100	F-100	F-100
Filter for SV 200, 300 B	–	F-200	F-200	F-200
Filter for SV 500 (B), 630 (B/F)	F-600	–	–	–
Filter for SV 1200	F-1200	–	–	–

Ordering Information

Dust Filter

	Part No.	Part No.	Part No.	Part No.
Dust Filter	Polyester Filter Cartridge	Metal Cartridge	Paper Cartridge	Activated Charcoal Cartridge
F-50	–	–	899 460	–
Replacement element for F-50	–	–	E 899 461	–
F-100	–	898 527	898 528	898 529
Replacement element for F-100	–	704 44 400	704 13 901	704 13 906
F-200	–	898 530	898 531	898 532
Replacement element for F-200	–	704 45 400	704 14 901	704 14 908
F-600	898 470	–	–	–
Replacement element for F-600	898 471	–	–	–
F-1200	898 475	–	–	–
Replacement element for F-1200	898 476	–	–	–

SL Liquid Traps



SOGEVAC SV 40 with SL 40 liquid trap

The SL 16-25 liquid trap consists of a collection vessel made of transparent plastic.

Liquid traps SL 40 to SL 1200 are welded steel collection vessels acting as liquid traps. These are equipped with connecting threads.

Liquid traps SL 630 and SL 1200 are equipped with a cleaning port DN 150 PN 10.

Advantages to the User

- Protection of the pumps against liquids which might condense in the intake or the exhaust line when pumping vapors

Technical Notes

The liquid traps are equipped with a sight glass tube, so that it is easy to determine when to empty the vessels. The liquid drain is sealed by a screw-in cap. This cap may be replaced by a drain valve.

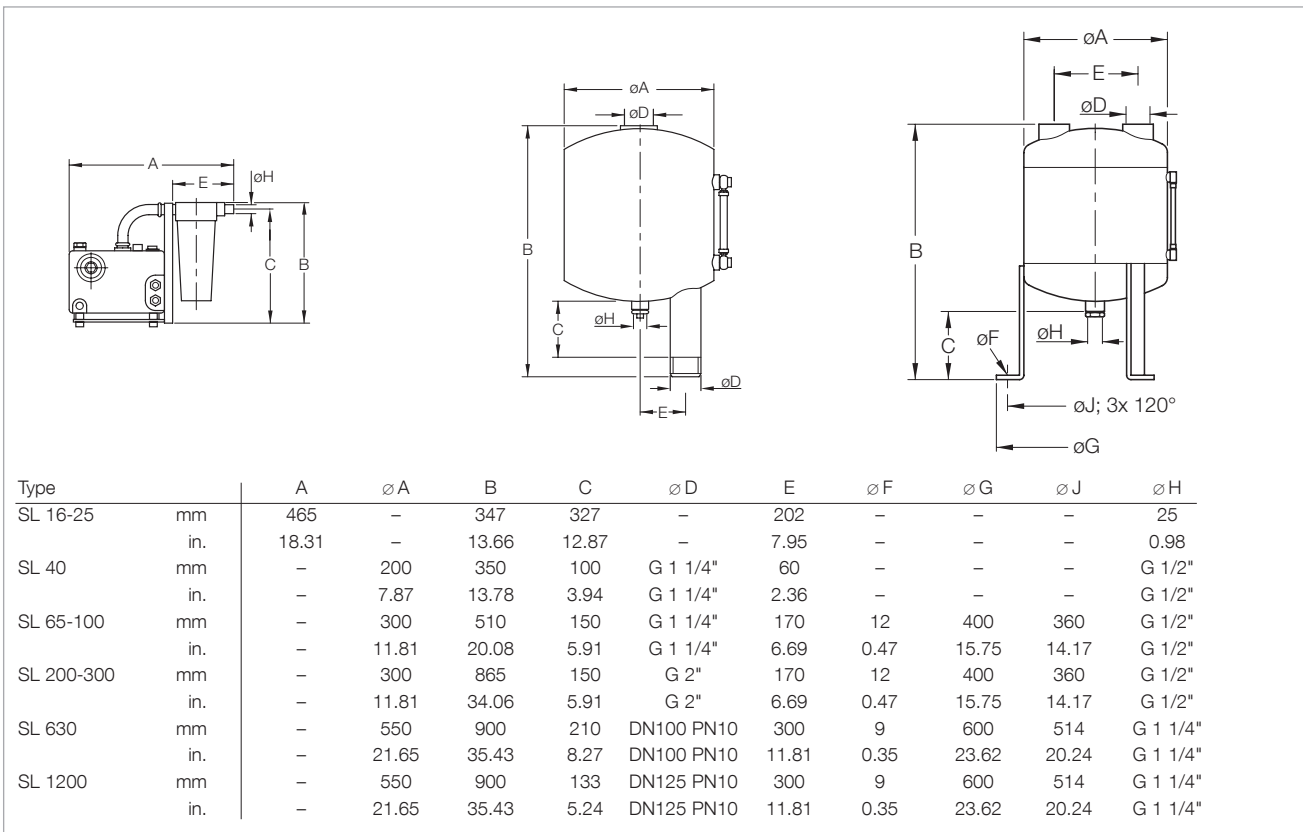

Dimensional drawings for the liquid traps; SL 16-25 (left), SL 40 (middle) and SL 65-100 up to SL 1200 (right)

Technical Data

		SL 16-25	Liquid Traps SL 40	SL 65-100
For pump	SOGEVAC	for pumps from 10 to 25 m ³ /h	SV 40 B	SV 40 B/65 B/100 B
Condensate capacity	l (qt)	2.0 (2.1)	4.0 (4.2)	16.0 (16.9)
Weight	kg (lbs)	3.5 (7.7)	5.0 (11.0)	11.0 (24.3)

Ordering Information

		SL 16-25	Liquid Traps SL 40	SL 65-100
		Part No.	Part No.	Part No.
Liquid trap		951 38	951 40	951 42
Liquid trap with electrical level switch		-	-	951 429 901
Drain valve		-	711 30 111	711 30 113

Technical Data

		SL 200-300	Liquid Traps SL 630	SL 1200
For pump	SOGEVAC	SV 200/300 B	SV 500/630/750 (B)(F)	SV 500/630/750 (B)(F)/1200
Condensate capacity	l (qt)	40.0 (42.3)	80.0 (84.6)	80.0 (84.6)
Weight	kg (lbs)	17.0 (37.5)	58.0 (127.9)	59.0 (130.1)

Ordering Information

		SL 200-300	Liquid Traps SL 630	SL 1200
		Part No.	Part No.	Part No.
Liquid trap		951 44	951 47	951 48
Liquid trap with electrical level switch		951 449 900 001	-	-
Drain valve		711 30 113	711 30 105	711 30 105
Double spigot for drain valve		-	711 18 033	711 18 033

Only available for purchase in North and South America

Technical Data

		SL 16-25	Liquid Traps SL 40	SL 65-100
For pump	SOGEVAC	for pumps from 10 to 25 m ³ /h	SV 40 B	SV 40 B/65 B/100 B
Condensate capacity	l (qt)	2.0 (2.1)	4.0 (4.2)	16.0 (16.9)
Weight	kg (lbs)	3.5 (7.7)	5.0 (11.0)	11.0 (24.3)

Ordering Information

		SL 16-25	Liquid Traps SL 40	SL 65-100
		Part No.	Part No.	Part No.
Liquid trap		951 38 (BSP)	951 40 (NPT)	951 43 (NPT)
Liquid trap with electrical level switch		-	-	951 429 901
Drain valve		-	711 30 111	711 30 113

Technical Data

		SL 200-300	Liquid Traps SL 630	SL 1200
For pump	SOGEVAC	SV 200/300 B	SV 500/630/750 (B)(F)	SV 500/630/750 (B)(F)/1200
Condensate capacity	l (qt)	40.0 (42.3)	80.0 (84.6)	80.0 (84.6)
Weight	kg (lbs)	17.0 (37.5)	58.0 (127.9)	59.0 (130.1)

Ordering Information

		SL 200-300	Liquid Traps SL 630	SL 1200
		Part No.	Part No.	Part No.
Liquid trap		951 45 (NPT)	951 47 (BSP)	951 48 (BSP)
Liquid trap with electrical level switch		951 449 900 001	-	-
Drain valve		711 30 113	711 30 105	711 30 105
Double spigot for drain valve		-	711 18 033	711 18 033

SEP Separators / SEPC Condensers



The separators from the SEP and the condensers from the SEPC range have been designed to be integrated in the vacuum circuit. They are employed in all those cases where the pumped gases may contain liquid drops (SEP), condensable vapors (SEPC) or solid particles which may impair proper operation of the pumps.

Advantages to the User

- Large capacity for solids
- Large condensation surface (SEPC)
- Visible level
- Easy to disassemble for cleaning
- Easy to drain, even in the presence of solids

Typical Applications

- Draining (SEP)
- Packaging (SEP)
- Conveying/filling under vacuum (SEP/SEPC)
- Drying (SEPC)
- Degassing (SEPC)
- and many more

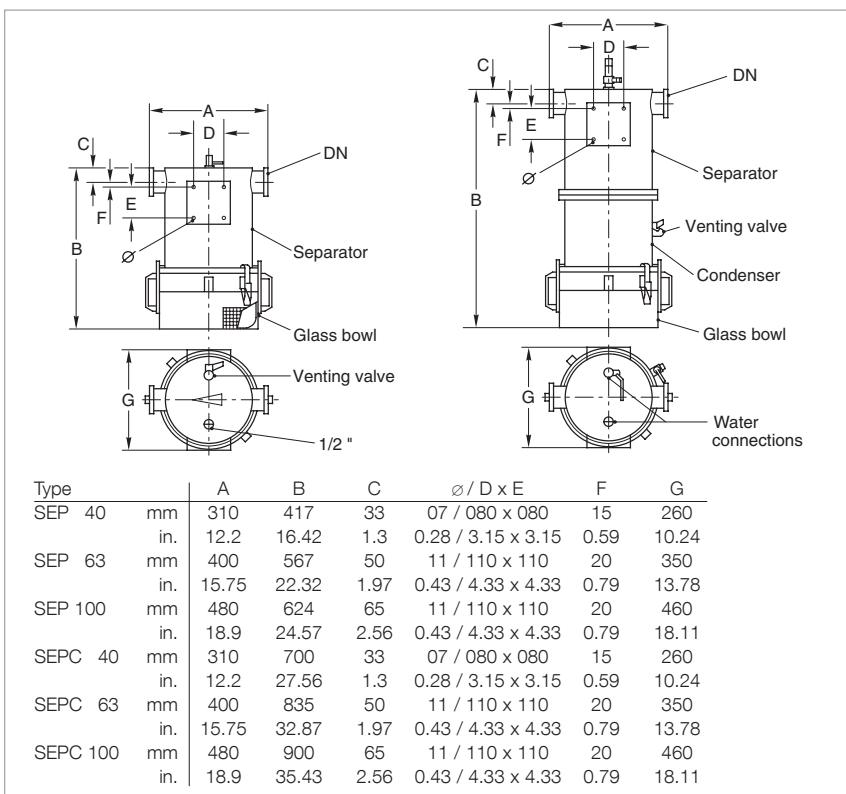

Dimensional drawings for the separators (left) and condensers (right)

Technical Data

Separator

		SEP 40	SEP 63	SEP 100
For pump	SOGEVAC	SV 40 B/65 B/100 B	SV 200/300 B	SV 630 (F)/750
Connection flange	DN	40 ISO-KF	63 ISO-K	100 ISO-K
Capacity of the bowl	l (qt)	6.0 (6.3)	12.0 (12.7)	12.0 (12.7)
Weight	kg (lbs)	15.0 (33.1)	20.0 (44.1)	40.0 (88.2)

Ordering Information

Separator

	SEP 40	SEP 63	SEP 100
	Part No.	Part No.	Part No.
Steel design	953 54	953 56	953 60
Stainless steel design	953 55	953 57	953 61
Support	712 43 380	712 43 380	712 43 380

Technical Data

Condenser

		SEPC 40	SEPC 63	SEPC 100
For pump	SOGEVAC	SV 40 B/65 B/100 B	SV 200/300 B	SV 630 (F)/750
Connection flange	DN	40 ISO-KF	63 ISO-K	100 ISO-K
Capacity of the bowl	l (qt)	6.0 (6.3)	12.0 (12.7)	12.0 (12.7)
Condensation area	m ²	2.5	5.0	5.0
Condensation capacity ¹⁾	l/h	10	20	20
Cooling water flow rate ²⁾	l/h	1500	3000	3000
Water connection dia.	mm (in.)	19.0 (0.75)	19.0 (0.75)	19.0 (0.75)
Weight	kg (lbs)	30.0 (66.2)	40.0 (88.2)	65.0 (143.3)

Ordering Information

Condenser

	SEPC 40	SEPC 63	SEPC 100
	Part No.	Part No.	Part No.
Steel design	953 64	953 66	953 68
Stainless steel design	953 65	953 67	953 69
Support	712 43 380	712 43 380	712 43 380

¹⁾ For water vapor at a vapor pressure of 60 mbar (45 Torr)

²⁾ Cooling water at a supply temperature of 10 °C (50 °F) and a discharge temperature < 15 °C (< 59 °F)

Remark: The stainless steel condensers have a copper heat exchanger coil

If required, the following products from the Catalog Part "Oil Sealed Vacuum Pumps TRIVAC" can be used for the small pumps SOGEVAC SV 10 to SV 25: condensate traps / separator AK, chapter "Accessories for TRIVAC".

Condensers for the large pump SOGEVAC SV 1200 upon request

Gas Ballast Valve

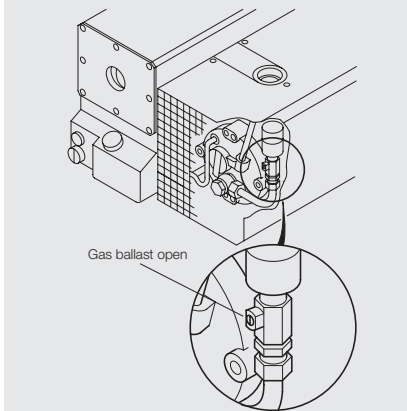

The pumps SOGEVAC SV 10 B, SV 16 B and SV 25 B are equipped depending of their Part No. without or with a permanent gas ballast.

The pumps SOGEVAC SV 16, SV 25, SV 40 B, SV 65 B, SV 100 B, SV 500 B(F), SV 630 B(F) and SV 750 B(F) are equipped depending of their Part No. without or with a manual, permanent or solenoid gas ballast.

The SV 1200 is equipped as standard with two manual gas ballast valves.

The gas ballast valve may also easily be retrofitted to the SV 40, SV 65, SV 100, SV 200 and SV 300 (either standard, large or solenoid).

Technical Notes

The gas ballast valve permits pumping of condensable vapors.

The permissible quantities of water are stated in the technical data section.

Thermal Switch

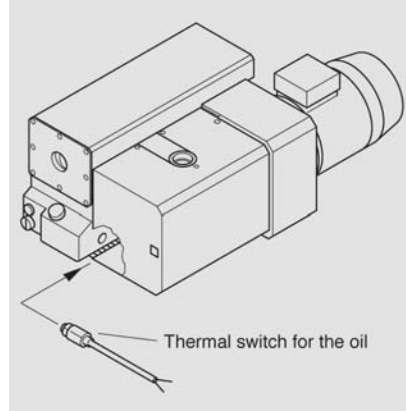

The thermal switch is installed at the hottest point of the pump module. It responds as soon as the temperature of the pump exceeds the maximum operating temperature. This accessory is recommended when operating the pump at high ambient temperatures.

Ratings for the normally closed contact:

25 V AC, 50 Hz - 5 A

60 V DC - 3 A

The SV 500, SV 630, SV 750 B(F) and SV 1200 include this switch as a standard.

Ordering Information

Accessories

		Part No.	Part No.	Part No.	Part No.
For pump	SOGEVAC	SV 16 (B)/25	SV 25 B	SV 28 BI	SV 40 B
Gas ballast valve (standard)		integrated	integrated	971 462 640	²⁾
Thermal switch		–	²⁾	upon request	³⁾
Oil level monitor		711 19 108	²⁾	–	711 19 110
Gas ballast big		–	²⁾ ⁵⁾	–	⁴⁾
Gas ballast, electromagnetic with 24 V DC valve		–	–	upon request	upon request
Exhaust filter monitoring switch		–	–	–	971 425 890

Ordering Information

Accessories

		Part No.	Part No.	Part No.	Part No.
For pump	SOGEVAC	SV 40 BI	SV 65 B	SV 100/120 B	SV 200 ^{3), 8)}
Gas ballast valve (standard)		¹⁾	¹⁾	¹⁾	951 29
Thermal switch		³⁾	³⁾	³⁾	951 36
Oil level monitor		711 19 110	711 19 110	711 19 110	953 96
Gas ballast, big		–	⁶⁾	⁷⁾	951 30
Gas ballast, electromagnetic with 24 V DC valve		upon request	upon request	upon request	951 31
Exhaust filter monitoring switch		971 425 890	971 425 890	971 425 890	712 22 360

Ordering Information

Accessories

		Part No.	Part No.	Part No.
For pump	SOGEVAC	SV 300 B	SV 500 B(F), SV 630 B(F), 750 B(F) ^{3), 8)}	SV 1200
Gas ballast valve (standard)		971 464 130 ⁹⁾	integrated (24 V DC)	integrated (manual)
Thermal switch		971 463 930	integrated	integrated
Oil level monitor		upon request	971 425 760	953 99
Gas ballast kit		971 464 130 ⁹⁾	–	–
Gas ballast, electromagnetic with 24 V DC valve		upon request	971 438 170	upon request ³⁾
Exhaust filter monitoring switch		upon request	712 22 360	712 22 360

¹⁾ According to variant

²⁾ Can not be retrofitted

³⁾ Please state when ordering the pump

⁴⁾ See pump with Part No. 960 305 V 2040

⁵⁾ See pump with Part No. 960 251 V 2040

⁶⁾ See pump with Part No. 960 405 V 0040

⁷⁾ See pump with Part No. 960 505 V 2040

⁸⁾ Second gas ballast possible. Contact Leybold Vacuum

⁹⁾ SV 300 B gas ballast kit (Part No. 971 464 130) includes all parts for small, standard and big gas flow

Mobile Base Frame



Mobile base frame

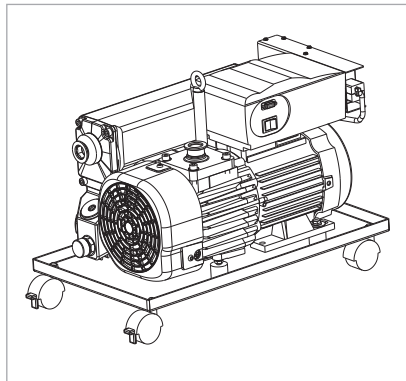

SOGEVAC pump upon mobile base frame

The mobile base frame allows moving easily single and double stage rotary vane pumps up to 65 m³/h and facilitates therefore their maintenance.

The oil tight base frame allows to hold up to 2 l (2,1 qt) oil and has swivable casters of which 2 have breaks.

The base frame doesn't alter the pump noise and facilitates oil draining and pump displacement.

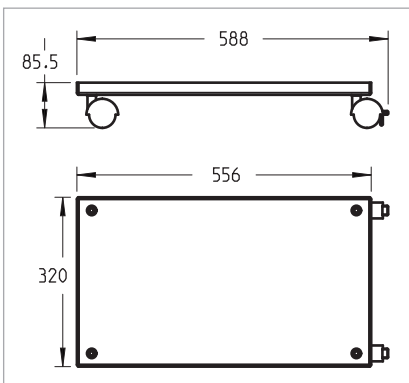

Dimensional drawing for the mobile base frame

Technical Data

Mobile Base Frame

Net weight, approx.	kg (lbs)	3 (7)
Max. load	kg (lbs)	90 (200)
Oil recovery volume, max.	l (qt)	2 (2.1)
Caster diameter	mm (in)	50 (2)
Material oil pan		Stainless steel

Ordering Information

Mobile Base Frame

		Part No.
For pump	SOGEVAC	Single and double stage pumps up to 65 m ³ /h
Mobile base frame		960 331 BASE

Noise Enclosure

Leybold Vacuum has developed a specific noise enclosure for vacuum pumps, which reduce the noise level by approx. 5 dB(A) and which makes sure the pump doesn't overheat due to the open design on both sides.

A combination with the mobile base frame is possible.

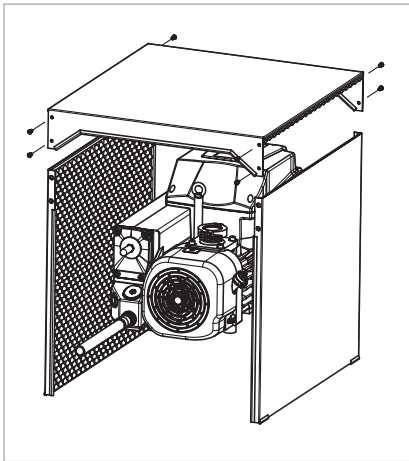

Noise enclosure

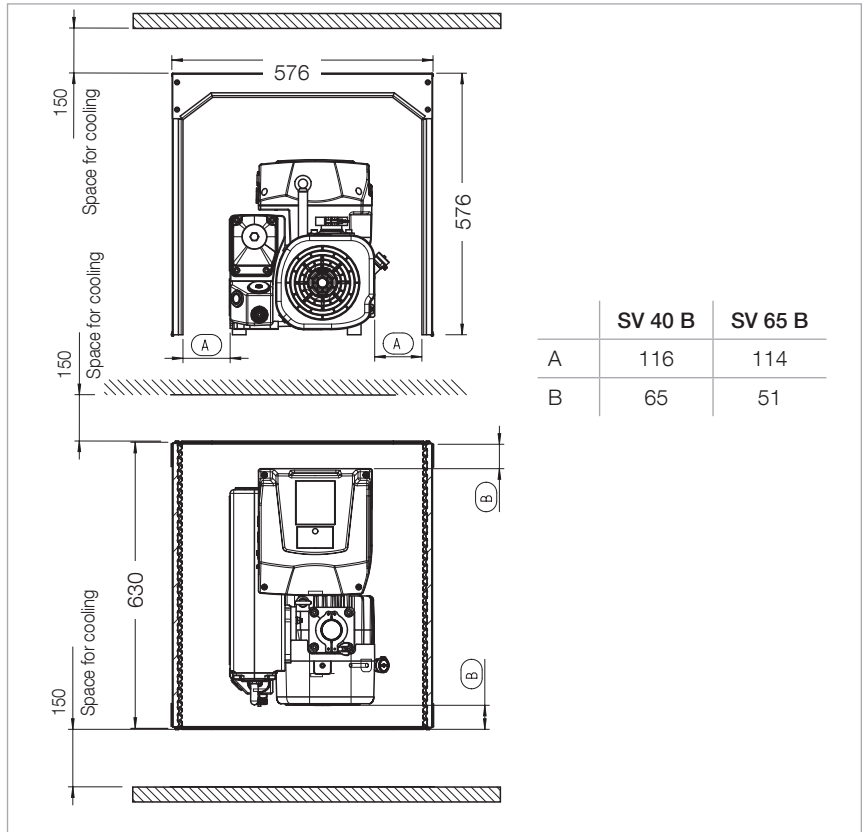

Dimensional drawing for the noise enclosure, dimensions in mm

Technical Data

Noise Enclosure

Net weight, approx.	kg (lbs)	12.2 (27)
Noise reduction, approx.	dB(A)	5
Temperature increase below top, max.	°C (°F)	7 (45)
Ambient temperature, max.	°C (°F)	34 (93)
Material frame absorption foam material		Galvanised steel acc. UL-94 HF1

Ordering Information

Noise Enclosure

		Part No.	Part No.
For pumps	SOGEVAC	Single stage rotary vane pumps up to 65 m ³ /h and double stage rotary vane pumps up to 25 m ³ /h -	- Single stage rotary vane pumps up to 120 m ³ /h and double stage rotary vane pumps up to 65 m ³ /h
Noise enclosure		960 331 NENC	960 560 NENC

Mounting Accessories

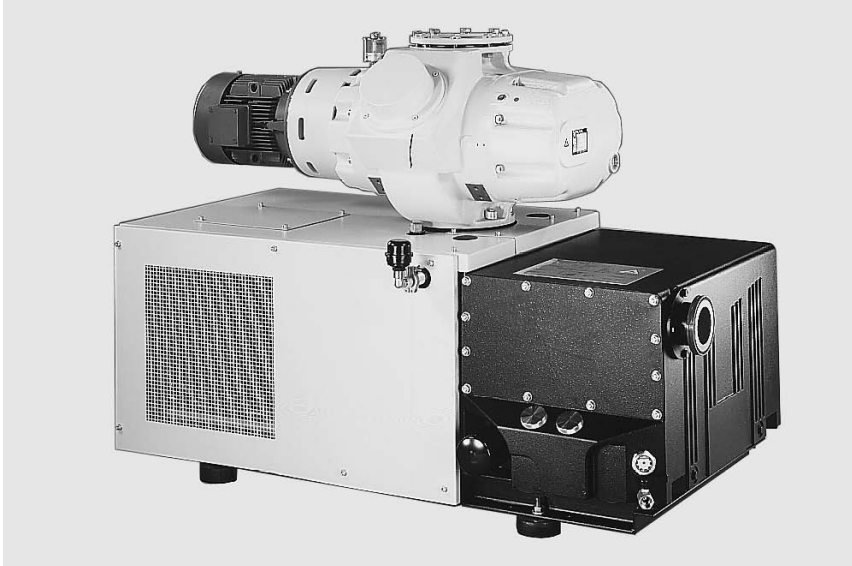

SOGEVAC SV 630 F with RUVAC WAU 2001



SOGEVAC SV 200 with RUVAC WAU 501

Ordering Information

Mounting Accessories

		Part No.	Part No.	Part No.	Part No.	Part No.
For pump	SOGEVAC	SV 16 BI	SV 25 B	SV 28 BI	SV 40 B	SV 40 BI
Oil drain valve G 3/4"		711 30 114	711 30 114	711 30 114	711 30 114	711 30 114
Base frame for Roots installation		not possible	not possible	not possible	not possible	not possible

Ordering Information

Mounting Accessories

		Part No.	Part No.	Part No.	Part No.
For pump	SOGEVAC	SV 40 + SV 65 B	SV 100 B	SV 200	SV 300 B
Base frame		971 453 840	971 434 000	711 19 208	711 19 208
Oil drain valve G 3/4"		711 30 114	711 30 114	711 30 114	711 30 114
Bracket for electric connections		-	-	711 19 226	upon request
Base frame for Roots installation		not possible	971 448 830 ¹⁾	711 19 209 ²⁾	971 456 590

¹⁾ Mandatory for direct Roots mounting

²⁾ Required for mounting the WAU 1001 on to the SV 200

Exhaust Filter Gauge

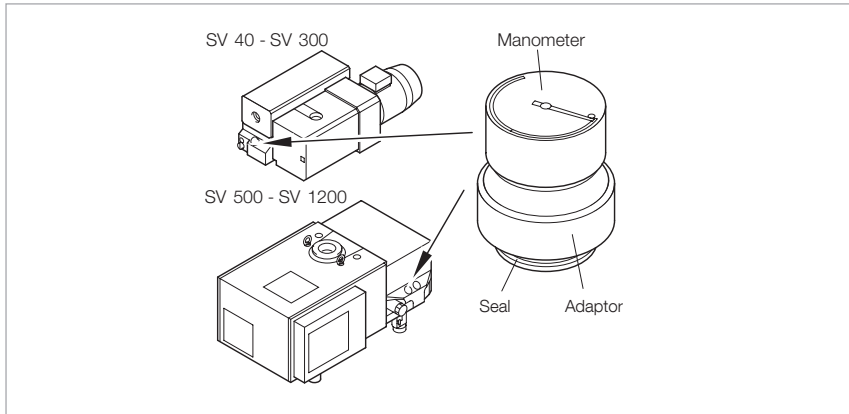

The manometer (40 mm (1.58 in.) dia.), glued in the adaptor, is installed instead of the oil filling plug. Dial has 2 colors:

green: $1000 < p < 1450$ mbar abs.
($760 < p < 1090$ Torr abs.)
Exhaust filter OK

red: $p > 1450$ mbar abs.
(> 1090 Torr abs.)
Exhaust filter clogged

Technical Notes

The reliability of the manometer applies only provided the pump has attained

its operating temperature and when the intake pressure is high.

Ordering Information

Exhaust Filter Gauge

		Part No.	Part No.	Part No.
For pump	SOGEVAC	SV 10 B to SV 65 B, SV 16 BI, SV 28 BI and SV 40 BI	SV 100 B to SV 300 B, SV 500 B(F) to SV 750 B(F)	SV 1200 ¹⁾
Manometer (with adaptor and seal)		951 93	951 94	951 95

¹⁾ Not visible from outside

Ball Valves and Valves



Ball valve 1 1/4"

Advantages to the User

- Leak rate $< 1 \times 10^{-6}$ mbar x l/s ($\leq 0.75 \times 10^{-6}$ Torr x l x s⁻¹)
- Seals on both sides against the atmosphere
- Opens against atmospheric pressure
- Small size
- Simple and quick to operate
- Pressure range from 10^{-2} to 1000 mbar (0.75×10^{-2} to 750 Torr)
- Smaller models serve as venting valves

Information on the blocking components is provided in the Catalog Part "Vacuum Valves".

Material

The housing of the ball valves is made of brass, the ball of hard-chrome plated brass, the valve seat of PTFE.

The housing of the right angle valve is made of aluminium, the spindle and valve plate are sealed with an O-ring and are made of stainless steel.

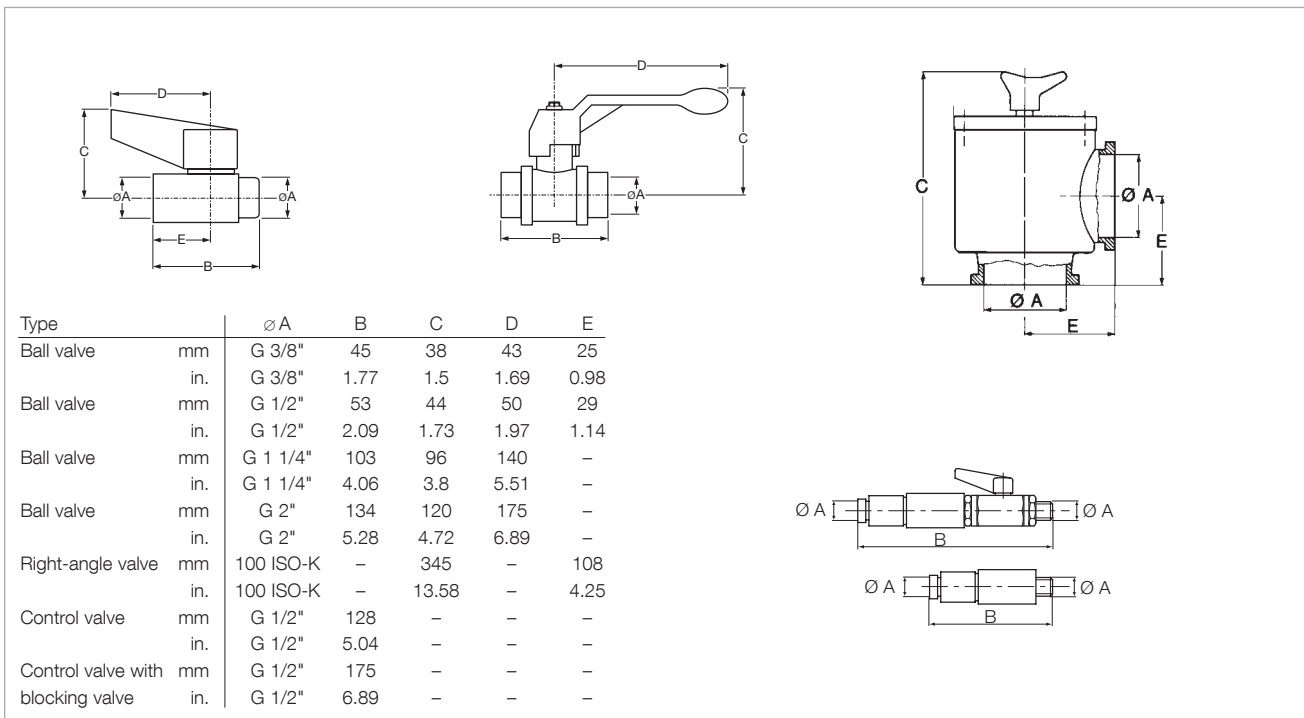

Dimensional drawings for the ball valves; G 3/8" and G 1/2" (left), G 1 1/4" and G 2" (middle), right-angle valves (right) and for the control valves (bottom)

Technical Data

Ball Valves and Valves ¹⁾

Type	Ball valve	Ball valve	Ball valve	
Connection	F/M 3/8" BSP	F/M 1/2" BSP	F/F 1 1/4" BSP	
Weight	kg (lbs)	0.12 (0.3)	0.15 (0.33)	1.24 (2.7)

Ordering Information

Ball Valves and Valves ¹⁾

	Part No.	Part No.	Part No.
Type	Ball valve	Ball valve	Ball valve
	971 471 220	711 30 113	711 30 100

Technical Data

Ball Valves and Valves ¹⁾

Type	Ball valve			
Connection	F/F 2" BSP			
Weight	kg (lbs)	3.22 (7.1)		

Ordering Information

Ball Valves and Valves ¹⁾

	Part No.			
Type	Ball valve			
	711 30 107			

¹⁾ Special versions for oxygen applications are available upon request

Only available for purchase in North and South America

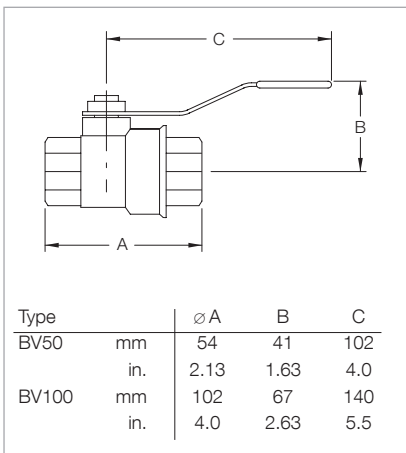

Dimensional drawing for the ball valves BV

Technical Data

Ball Valves

Type	Ball valve	Ball valve
Connection	1/2-inch NPT(F)	1 1/4-inch NPT(F)

Ordering Information

Ball Valves

	Part No.	Part No.
Type	BV50	BV100
	899 810	899 800

Bourdon Vacuum Gauges / DIAVAC DV 1000

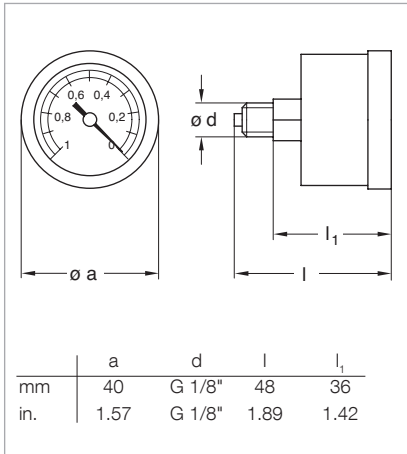
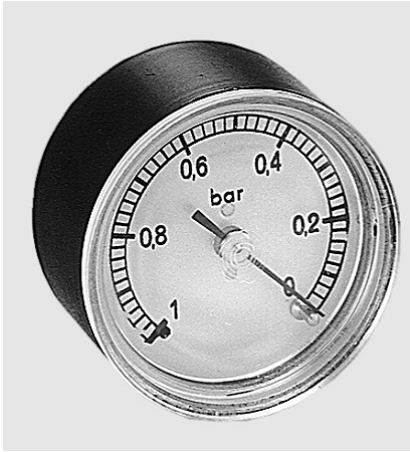

Dimensional drawing for the Bourdon vacuum gauge Part No. 951 90

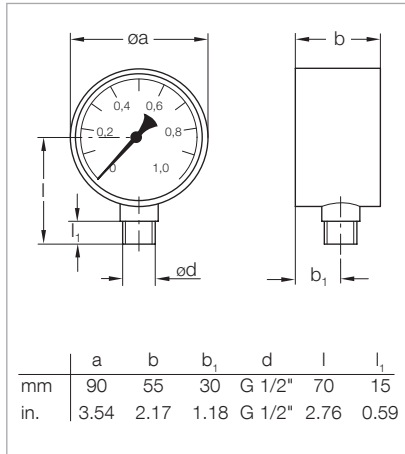

Dimensional drawing for the Bourdon vacuum gauge Part No. 951 92

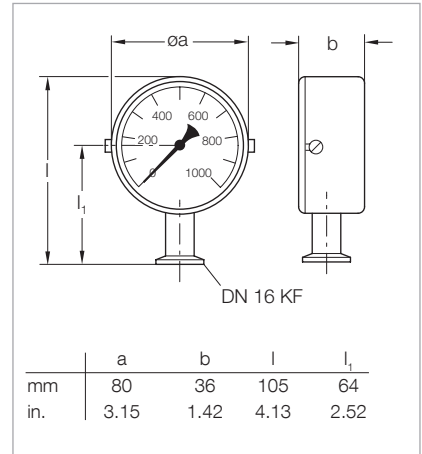

Dimensional drawing for the Bourdon vacuum gauge Part No. 160 40



DIAVAC DV 1000

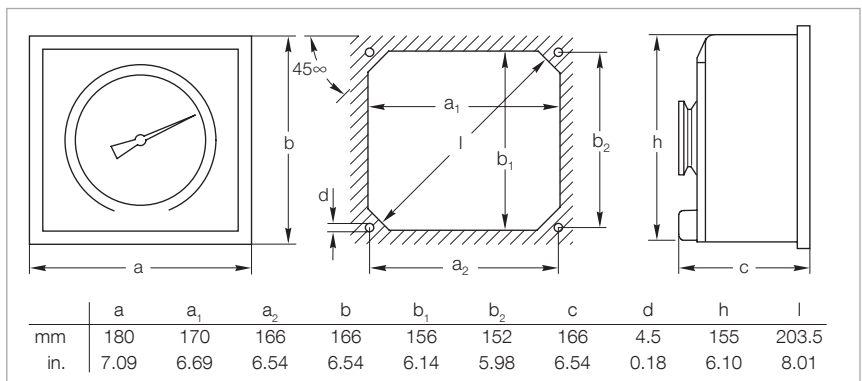

Dimensional drawing and panel cut-out for the DIAVAC DV 1000, Part No. 160 67

Advantages to the User

- Simple, rugged and vibration insensitive vacuum gauges for the rough vacuum range
- Linear response
- Clear dial which can also be read from a great distance
- Readings independent of atmospheric pressure

Technical Data

Bourdon Vacuum Gauges / DIAVAC DV 1000

Measuring range		0 to 100%	0 to 1 bar	0 to 1020 mbar	1 to 1000 mbar
Vacuum connection		M 1/8" BSP	M 1/2" BSP	DN 16 ISO-KF	DN 40 ISO-KF
Scale length	mm (in.)	55 (2.17)	140 (5.51)	140 (5.51)	270 (10.63)
Overall height	mm (in.)	48 (1.89)	115 (4.53)	105 (4.13)	166 (6.54)
Weight	g (lbs)	60 (0.13)	560 (1.24)	300 (0.66)	2700 (5.96)
Indication		low pressure in bar	absolute pressure in mbar	absolute pressure in mbar	absolute pressure in mbar

Ordering Information

Bourdon Vacuum Gauges / DIAVAC DV 1000

	Part No.	Part No.	Part No.	Part No.
Bourdon Vacuum Gauges	951 90	951 92	160 40	-
DIAVAC DV 1000	-	-	-	160 67

Standard vacuum gauge for all SOGEVAC pumps is Part No. 951 92.

Further information on other vacuum gauges is provided in Catalog Part "Vacuum measuring - controlling"

Only available for purchase in North and South America

Other Accessories

External Carbon Exhaust Filters

An external type spin-on filter made of activated carbon on a polyester cloth housed in wire mesh. Used for providing additional protection from oil odor or mist expelled from pump exhaust.

Requires NPT type nipple and street elbow for preferred vertical mounting. SV 16/25 requires nipple only.

Technical Data

Model		SVXCXF 50	SVXCXF 100	SVXCXF 200
Fits pump	SOGEVAC	SV 16 / 25 (B)	SV 40 B / 65 B SV 100 B	SV 200/300
Thread size		1/2" NPT-M	1 1/4" NPT-M	2" NPT-M

External Carbon Exhaust Filters

Ordering Information

External Carbon Exhaust Filters

	Part No.	Part No.	Part No.
Model	SVXCXF 50	SVXCXF 100	SVXCXF 200
External carbon exhaust filters	899 502	899 500	899 498
Replacement element	899 503	899 501	899 499

Connection Fittings for SOGEVAC SV 10 B, SV 16, SV 16 B, SV 16 D, SV 25, SV 25 B, SV 25 D

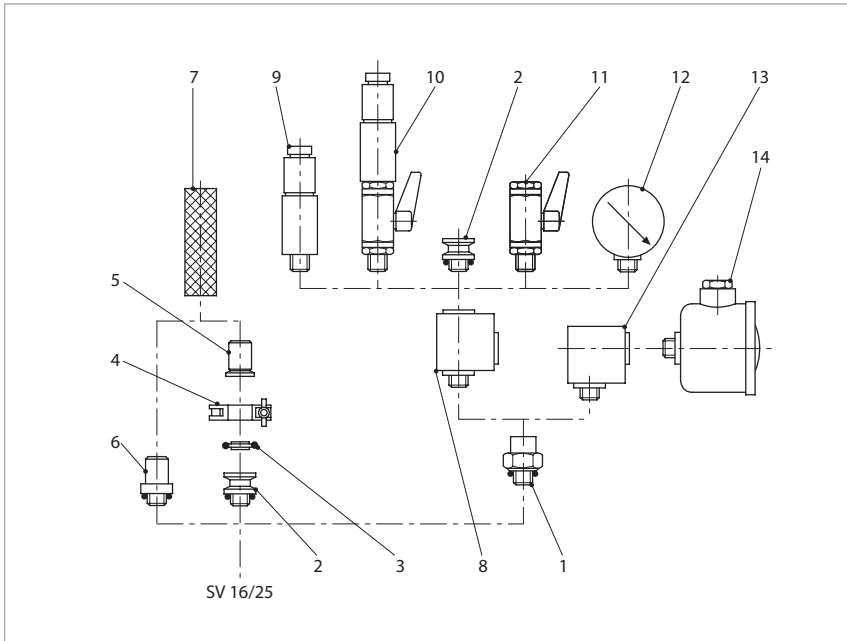

Connection fittings for SOGEVAC SV 10 B, SV 16 B, SV 25 B and SV 16, SV 25

The fittings presented have been specially matched to the SOGEVAC pumps. We recommend to use only these

or other components from Leybold for connecting SOGEVAC pumps, so as not to impair the pumping speed of the pumps or the leak tightness of the system.

More information on further fittings is provided in Catalog Part "Flanges and Fittings".

Technical Data

Connection Fittings

Item	Description	Connection	Material
1	Screw coupling	G 1/2" M/F	Aluminium
2	Threaded flange adaptor ¹⁾	G 1/2" M – DN 16 ISO-KF	Aluminium, anodized
3	Centering ring ¹⁾	DN 16 ISO-KF	Aluminium
4	Clamping ring	DN 10/16 ISO-KF	Aluminium
5	Hose connection	DN 16 ISO-KF – DN 25 mm (0.39 in.)	Aluminium, anodized
6	Hose connection ¹⁾	G 1/2" M – DN 25 mm (0.39 in.)	Aluminium, anodized
7	PVC tubing	25 mm (0.39 in.) dia., 1 m (3.5 ft) long	PVC
8	Tee piece	G 1/2" M/F/F	Aluminium, anodized
9	Vacuum control valve	G 1/2" M	Brass/Aluminium
10	Vacuum control valve with blocking valve	G 1/2" M	Brass, nickeled/Aluminium
11	Ball valve	G 1/2" M/F	Brass, nickeled
12	Bourdon vacuum gauge	G 1/2" M	
13	Elbow 90°	G 1/2" M/F	Aluminium, anodized
14	Dust filter	G 1/2" M/F	
15	Inlet reduction ¹⁾ (not shown)	G 1/2" M - G 3/4" F	galvanised steel

¹⁾ With NBR-O-Ring

M = Outside thread

F = Inside thread

Ordering Information

Connection Fittings

Item	Description	SV 10 B	SV 16, 16 B, 16 D	SV 25, 25 B, 25 D
		Part No.	Part No.	Part No.
1	Screw coupling	711 18 020	711 18 020	711 18 020
2	Screw coupling ¹⁾	711 18 120	711 18 120	711 18 120
3	Centering ring ¹⁾	183 26	183 26	183 26
4	Clamping ring	183 41	183 41	183 41
5	Hose connection	711 18 300	711 18 300	711 18 300
6	Hose connection ¹⁾	711 18 011	711 18 011	711 18 011
7	PVC tubing	711 18 323	711 18 323	711 18 323
8	Tee piece	711 18 250	711 18 250	711 18 250
9	Vacuum control valve	951 86	951 86	951 86
10	Vacuum control valve with blocking valve	951 87	951 87	951 87
11	Ball valve	711 30 113	711 30 113	711 30 113
12	Bourdon vacuum gauges	951 92	951 92	951 92
13	Elbow 90°	711 18 210	711 18 210	711 18 210
14	Dust filter ²⁾ with paper cartridge	951 50	951 50	951 50
	with activated charcoal cartridge	711 27 092	711 27 092	711 27 092
	with metal cartridge	711 27 093	711 27 093	711 27 093
	with polyester filter cartridge	711 27 094	711 27 094	711 27 094
15	Inlet reduction ¹⁾ (not shown)	951 24	951 24	951 24

Special versions for oxygen applications are available upon request

¹⁾ With NBR-O-Ring

²⁾ See "Dust Filters F (Suction Side)" for other options

Connection Fittings for SOGEVAC SV 40 B, SV 65 B, SV 100 B

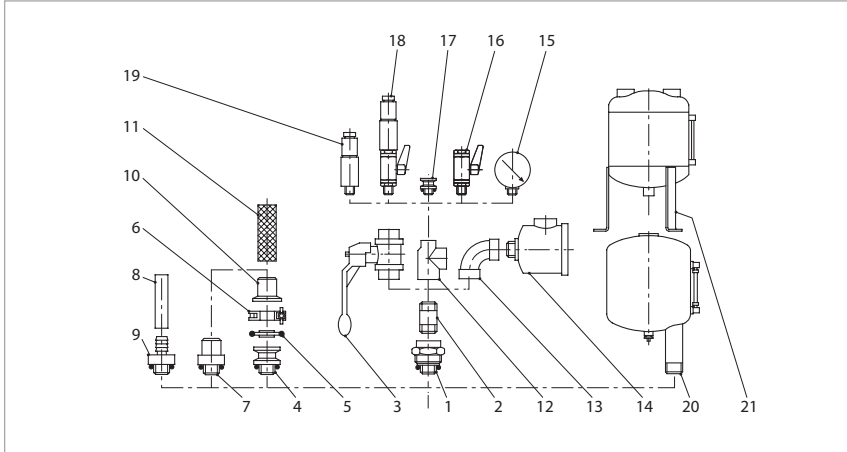

Connection fittings for SOGEVAC SV 40 B, SV 65 B, SV 100 B

Technical Data

Connection Fittings

Item	Description	Connection	Material
1	Screw coupling ¹⁾	G 1 1/4" M/F	Aluminium, NBR
2	Double nipple	G 1 1/4" M/M	Steel
3	Ball valve	G 1 1/4" F/F	Brass, nickeled
4	Threaded flange adaptor ¹⁾	G 1 1/4" M – DN 40 ISO-KF	Aluminium, anodized
5	Centering ring	DN 40 ISO-KF	Aluminium
6	Clamping ring	DN 32/40 ISO-KF	Aluminium
7	Hose connection ¹⁾	G 1 1/4" M / DN 40 mm (1.58 in.)	Aluminium, anodized
8	Rubber hose	dia 10 x 25 mm (0.39 x 0.98 in.), 1 m (3.5 ft) long	
9	Hose connection ¹⁾	G 1 1/4" M – DN 10	Aluminium, anodized
10	Hose connection	DN 40 ISO-KF/DN 40 mm (1.58 in.)	Aluminium, anodized
11	PVC tubing	40 mm (1.58 in.) dia., 1 m (3.5 ft) long	
12	Tee reducer bush	G 1 1/4" – 1 1/4" – 1/2" F/F/F	Gray cast iron
13	Elbow 90°	G 1 1/4" F/F	Gray cast iron
14	Dust filter	G 1 1/4" M/F	
15	Bourdon vacuum gauge	G 1/2" M	
16	Ball valve	G 1/2" M/F	Brass, nickeled
17	Threaded flange adaptor ¹⁾	G 1/2" M – DN 16 ISO-KF	Aluminium, anodized
18	Vacuum control valve with blocking valve	M 1/2" BSP	Brass, nickeled/Aluminium
19	Vacuum control valve	M 1/2" BSP	Brass, nickeled/Aluminium
20	Liquid trap	G 1 1/4" – 1 1/4" – 3/8" M/F	
21	Liquid trap	G 1 1/4" – 1 1/4" – 1/2" F/F/F	

¹⁾ incl. O-ring

M = Outside thread

F = Inside thread

Ordering Information

Connection Fittings

		SV 40 B	SV 65 B	SV 100 B
		Part No.	Part No.	Part No.
Item	Description			
1	Screw coupling ¹⁾	711 18 023	711 18 023	711 18 023
2	Double nipple	711 18 033	711 18 033	711 18 033
3	Ball valve	711 30 105	711 30 105	711 30 105
4	Threaded flange adaptor ¹⁾	711 18 123	711 18 123	711 18 123
5	Centering ring	183 28	183 28	183 28
6	Clamping ring	183 43	183 43	183 43
7	Hose connection ¹⁾	711 18 013	711 18 013	711 18 013
8	Rubber hose	172 03	172 03	172 03
9	Hose connection ¹⁾	711 18 153	711 18 153	711 18 153
10	Hose connection	711 18 303	711 18 303	711 18 303
11	PVC tubing	711 18 324	711 18 324	711 18 324
12	Tee reducer bush	711 18 263	711 18 263	711 18 263
13	Elbow 90°	711 18 213	711 18 213	711 18 213
14	Dust filter ²⁾ with paper cartridge with activated charcoal cartridge with metal cartridge with polyester filter cartridge	951 55 711 27 102 711 27 103 711 27 104	951 60 711 27 112 711 27 113 711 27 114	951 60 711 27 112 711 27 113 711 27 114
15	Bourdon vacuum gauge	951 92	951 92	951 92
16	Ball valve	711 30 113	711 30 113	711 30 113
17	Threaded flange adaptor ¹⁾	711 18 120	711 18 120	711 18 120
18	Vacuum control valve with blocking valve	951 87	951 87	951 87
19	Vacuum control valve	951 86	951 86	951 86
20	Liquid trap	951 40	-	-
21	Liquid trap	951 42	951 42	951 42

Special versions for oxygen applications are available upon request

¹⁾ With NBR-O-Ring

²⁾ See "Dust Filters F (Suction Side)" for other options

Connection Fittings for SOGEVAC SV 200, SV 300 B

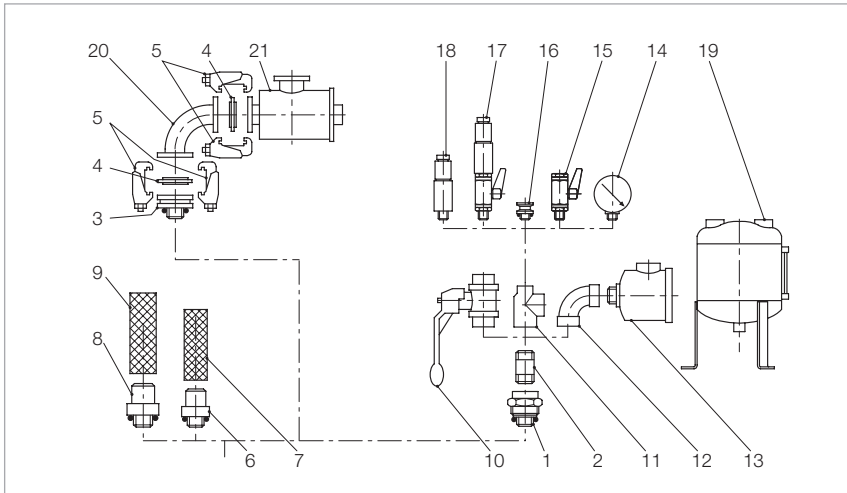

Connection fittings for SOGEVAC SV 200 and SV 300 B

Technical Data

Connection Fittings

Item	Description	Connection	Material
1	Screw coupling ¹⁾	G 2" M/F	Aluminium, anodized
2	Double nipple	G 2" M/M – 150 mm (5.9 in.)	Steel
3	Threaded flange adaptor ¹⁾	G 2" M – DN 63 ISO-K	Steel, zinc coated
4	Centering ring with outer ring ¹⁾	DN 63 ISO-K	Aluminium, CR
5	Set of clamping screws DN ISO-K (4 pieces)	M10 x 24	Steel, zinc coated
6	Hose connection ¹⁾	G 2" M – DN 50 mm (1.97 in.)	Aluminium, anodized
7	PVC tubing	∅ 50 mm (1.97 in.), 1 m (3.5 ft) long	PVC
8	Hose connection ¹⁾	G 2" M – DN 60 mm (2.36 in.)	Aluminium, anodized
9	PVC tubing	∅ 60 mm (2.36 in.), 1 m (3.5 ft) long	PVC
10	Ball valve	G 2" F/F	Brass, nickered
11	Tee reducer	G 2" – 2" – 1/2" F/F/F	Gray cast iron
12	Elbow 90°	G 2" F/F	Gray cast iron
13	Dust filter	G 2" M/F	
14	Bourdon vacuum gauge	G 1/2" M	
15	Ball valve	G 1/2" M/F	Brass, nickered/Aluminium
16	Threaded ISO-KF small-flange adaptor ¹⁾	G 1/2" M – DN 16 ISO-KF	Aluminium, anodized
17	Vacuum control valve with blocking valve	G 1/2" M	Brass, nickered/Aluminium
18	Vacuum control valve	G 1/2" M	Brass, nickered/Aluminium
19	Liquid trap	G 2" – 2" – 1/2" F/F/F	
20	Elbow 90°	DN 63 ISO-K	Stainless steel
21	Dust filter with paper cartridge	DN 63 ISO-K	

¹⁾ incl. O-ring

M = Outside thread

F = Inside thread

Ordering Information

Connection Fittings

		SV 200	SV 300 B
		Part No.	Part No.
Item	Description		
1	Screw coupling ¹⁾	711 18 025	711 18 025
2	Double nipple	711 18 035	711 18 035
3	Threaded flange adaptor ¹⁾	711 18 126	711 18 126
4	Centering ring with outer ring ¹⁾	268 05	268 05
5	Set of clamping screws DN ISO-K (4 pieces)	267 01	267 01
6	Hose connection ¹⁾	711 18 015	711 18 015
7	PVC tubing	711 18 325	711 18 325
8	Hose connection ¹⁾	711 18 016	P711 18 016
9	PVC tubing	711 18 326	711 18 326
10	Ball valve	711 30 107	711 30 107
11	Tee reducer	711 18 265	711 18 265
12	Elbow 90°	711 18 215	711 18 215
13	Dust filter ²⁾ with paper cartridge	951 65	951 65
	with activated charcoal cartridge	711 27 122	711 27 122
	with metal cartridge	711 27 123	711 27 123
	with polyester filter cartridge	711 27 124	711 27 124
14	Bourdon vacuum gauge	951 92	951 92
15	Ball valve	711 30 113	711 30 113
16	Threaded ISO-KF small-flange adaptor ¹⁾	711 18 120	711 18 120
17	Vacuum control valve with blocking valve	951 87	951 87
18	Vacuum control valve	951 86	951 86
19	Liquid trap	951 44	951 44
20	Elbow 90°	887 25	887 25
21	Dust filter with paper cartridge	951 68	951 68

Special versions for oxygen applications are available upon request

¹⁾ With NBR-O-Ring

²⁾ See "Dust Filters F (Suction Side)" for other options

Connection Fittings for SOGEVAC SV 470 B(F), SV 570 B(F)

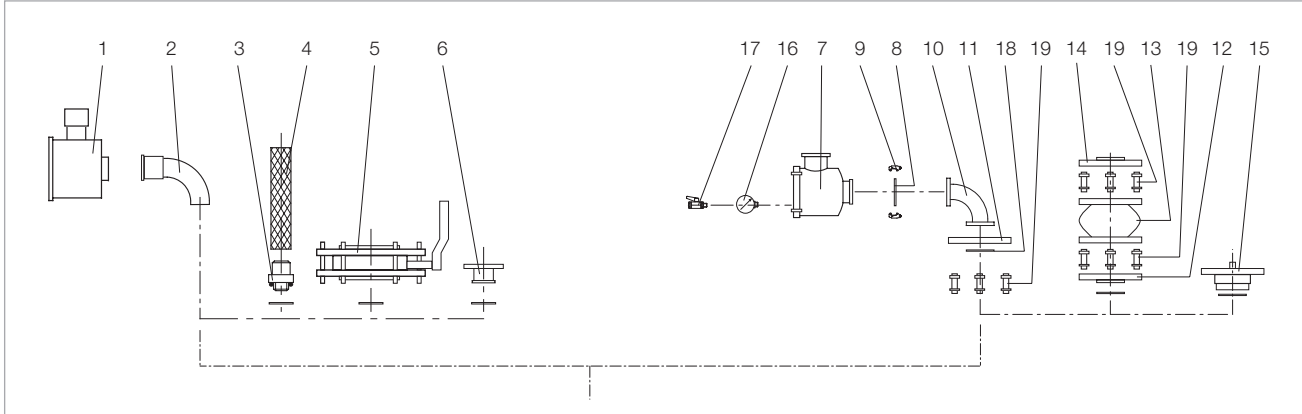

Connection fittings for SOGEVAC SV 470 B(F), SV 570 B(F)

Technical Data

Connection Fittings

Item.	Description	Connection	Material
1	Dust filter with paper cartridge with metal cartridge with activated charcoal cartridge	G3" F/M	Steel, zinc coated
2	Elbow 90°	G3" M/F	Cast iron, painted
3	Adaptor	G3" M – DN 90	Steel, painted
4	PVC hose	Ø 90 mm, 1 m long	
5	Manual valve	G3" M/F	Cast iron, painted
6	Flange	G3" M – DN 100 ISO-K	Aluminium
7	Dust filter with paper cartridge with metal cartridge with activated charcoal cartridge with polyester filter cartridge	DN 100 ISO-K DN 100 ISO-K DN 100 ISO-K DN 100 ISO-K	Steel, painted Steel, painted Steel, painted Steel, painted
8	Centering ring with O-ring	DN 100 ISO-K	Stainless steel
9	Set of clamping screws (4 pieces are required)	M10 x 24	galvanised steel
10	Elbow 90°	DN 100 ISO-K	Stainless steel
11	Adapter flange	DN 100 ISO-K, DIN 2501	Steel, painted
12	Collar flange	DN 100 PN 10 – G3" M	Steel, painted
13	Compensator	DN 100 PN 10	Steel / Rubber
14	Flange	DN 100 PN 10 – G3" F	Steel, painted
15	Double nipple	DN 100 ISO-K / DN 100 PN 10 – G3" M	Steel, painted
16	Filter manometer	G1/2" M	
17	Venting valve	G1/2" M/F	Steel
18	O-ring)		FPM (FKM)
19	Set of bolts	M16	Steel, zinc coated

M = Outside thread
F = Inside thread

Ordering Information**Connection Fittings****SV 470 B(F)****SV 570 B(F)**

Item	Description	Part No.	Part No.
1	Dust filter with paper cartridge with metal cartridge with activated charcoal cartridge	upon request upon request upon request	upon request upon request upon request
2	Elbow 90°	9516 223V	9516 223V
3	Adaptor	9516 221V	9516 221V
4	PVC hose	711 18 329	711 18 329
5	Manual valve	9516 225V	9516 225V
6	Flange	711 18 127	711 18 127
7	Dust filter with paper cartridge with metal cartridge with activated charcoal cartridge with polyester filter cartridge	951 72 711 27 167 711 27 166 711 27 168	951 72 711 27 167 711 27 166 711 27 168
8	Centering ring with O-ring	268 06	268 06
9	Set of clamping screws (4 pieces are required)	267 01	267 01
10	Elbow 90°	887 26	887 26
11	Adaptor flange	267 50	267 50
12	Collar flange	9516 226V	9516 226V
13	Compensator	711 18 342	711 18 342
14	Flange	711 18 370	711 18 370
15	Double nipple	9516 222V	9516 222V
16	Filter manometer	951 92	951 92
17	Venting valve	711 30 113	711 30 113
18	O-ring FPM (FKM)	712 42 892	712 42 892
19	Set of bolts	714 12 440	714 12 440

Special versions for oxygen applications are available upon request

¹⁾ With NBR O-ring

Connection Fittings for SOGEVAC SV 630 B(F), SV 750 B(F)

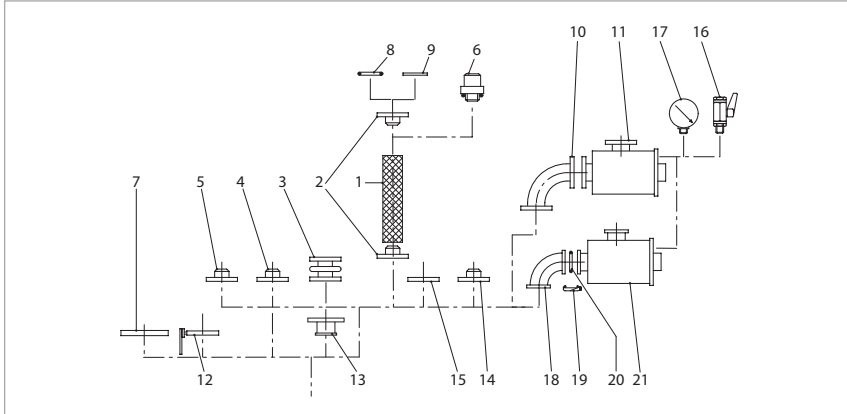

Connection fittings for SOGEVAC SV 630 B(F), SV 750 B(F)

Technical Data

Connection Fittings

Item	Description	Connection	Material
1	PVC tubing	90 mm (3.54 in.) dia., 1 m (3.5 ft) long	
2	Hose connection	DN 100 PN 10 – DN 90 mm (3.54 in.)	Steel
3	Coupling	DN 100 – PN 10	Stainless steel/Aluminium/Rubber
4	Adaptor flange	DN 100 PN 10 – G 4" F	Steel
5	Adaptor flange	DN 100 PN 10 – G 3" F	Steel
6	Hose connection	G 4" M – DN 90	Steel/NBR
7	Adaptor for Roots pump	RUVAC 1001 RUVAC 2001 RUVAC WH4400	Steel/NBR Steel/FPM (FKM) Steel/FPM (FKM)
8	O-ring	dia. 110 x 5 (3.94 x 0.2 in.)	NBR
9	Centering ring with O-ring	DN 100 PN 10 – DN 100 ISO-K	Aluminium/NBR
10	Elbow 90°	DN 100 PN 10	Steel
11	Dust filter F 630	DN 100 PN 10	
12	Manually operated blocking valve	DN 100 PN 10	Gray cast iron
13	Adaptor	DN 100 PN 10 – 100 ISO-K	Aluminium
14	Adaptor flange with tubulation	DN 100 PN 10 (tube dia. 108 (4.25 in.))	Steel
15	Collar flange	DN 100 PN 10 – DN 100 ISO-K	Steel
16	Ball valve	G 1/2" M/F	Brass, nickered/Aluminium
17	Bourdon vacuum gauge	G 1/2" M	
18	Elbow 90°	DN 100 ISO-K	Stainless steel
19	Set of clamps for DN ISO-K Set = 4 pieces	M 10 x 24	Steel, zinc coated
20	Centering ring	DN 100 ISO-K	Aluminium/CR
21	Dust filter	DN 100 ISO-K	
	Screw set (not drawn) Set = 8 screws and 8 nuts	DN 100 PN 10	Steel, zinc coated

M = Outside thread

F = Inside thread

Ordering Information

Connection Fittings

SV 630 B(F)

SV 750 B(F)

Item	Description	Part No.	Part No.
1	PVC tubing	711 18 329	711 18 329
2	Hose connection	711 18 362	711 18 362
3	Coupling	711 18 342	711 18 342
4	Adaptor flange	711 18 372	711 18 372
5	Adaptor flange	711 18 370	711 18 370
6	Hose connection	711 18 017	711 18 017
7	Adaptor for Roots pump		
	RUVAC 1000	971 432 340	971 432 340
	RUVAC 2000	971 432 350	971 432 350
	RUVAC WH4400	971 43 WH4400	971 43 WH4400
8	O-ring	712 42 882	712 42 882
9	Centerring ring with O-ring	711 18 391	711 18 391
10	Elbow 90°	711 18 284	711 18 284
11	Dust filter F 630 ¹⁾		
	with paper cartridge	951 71	951 71
	with activated charcoal cartridge	711 27 162	711 27 162
	with metal cartridge	711 27 163	711 27 163
	with polyester filter cartridge	711 27 164	711 27 164
12	Manually operated blocking valve	711 30 116	711 30 116
13	Adaptor	711 18 336	711 18 336
14	Adaptor flange with tubulation	711 18 351	711 18 351
15	Collar flange	711 18 383	711 18 383
16	Ball valve	711 30 113	711 30 113
17	Bourdon vacuum gauge	951 92	951 92
18	Elbow 90°	887 26	887 26
19	Clamp screws for DN ISO-K Set = 4 pieces	267 01	267 01
20	Centering ring ²⁾	268 06	268 06
21	Dust filter ¹⁾		
	with paper cartridge	951 72	951 72
	with activated charcoal cartridge	711 27 166	711 27 166
	with metal cartridge	711 27 167	711 27 167
	with polyester cartridge	711 27 168	711 27 168
	Screw set (not drawn) Set = 8 screws and 8 nuts	714 12 440	714 12 440

Special versions for oxygen applications are available upon request

¹⁾ See "Dust Filters F (Suction Side)" for other options

²⁾ incl. O-ring

Connection Fittings for SOGEVAC SV 1200

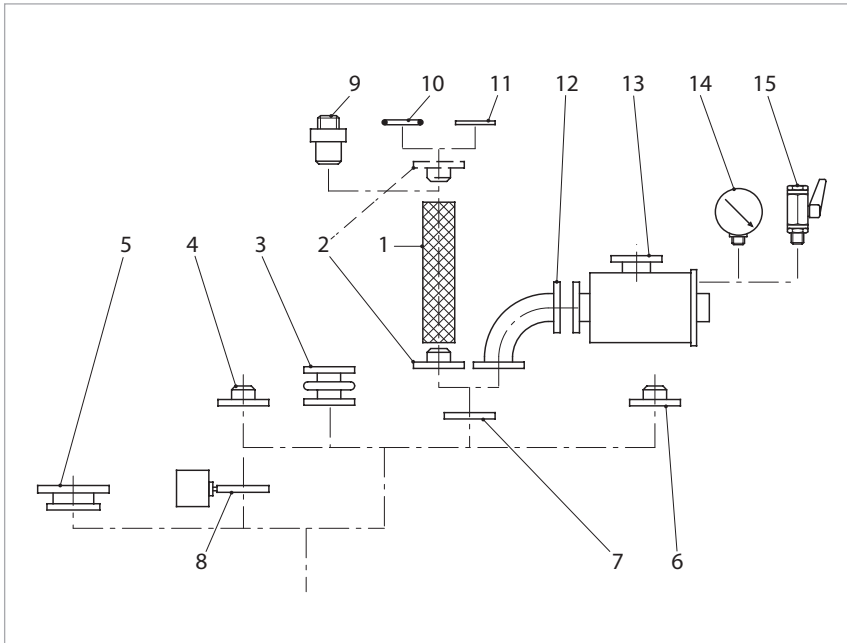

Connection fittings for SOGEVAC SV 1200

Technical Data

Connection Fittings

Item	Description	Connection	Material
1	PVC tubing	90 mm (3.54 in.) dia., 1 m (3.5 ft) long	PVC
2	Hose connection	DN 125 PN 10 – DN 90 mm (3.54 in.)	Steel
3	Coupling	DN 125 PN 10	Stainless steel/Aluminium/Rubber
4	Flange with tubulation ¹⁾	DN 125 (tube 139.7 (5.5 in.))	Steel
5	Adaptor for Roots pump	RUVAC 2001 RUVAC 3001 RUVAC WH 4400/7000	Steel Steel/FPM (FKM) Steel/FPM (FKM)
6	Adaptor flange	DN 125 PN 10 – G 4" F	Steel
7	Collar flange	DN 125 PN 10 – DN 160 ISO-K	Steel
8	Electropneumatic valve	DN 125 PN 10	Gray cast iron
9	Hose connection	G 4" M – DN 90 mm (3.54 in.)	Steel/NBR
10	O-ring 165 x 5 165 x 5		NBR FPM (FKM)
11	Centering ring ¹⁾	DN 125 PN 10 – DN 160 ISO-K	Aluminium
12	Elbow 90°	DN 125 PN 10	Steel
13	Dust filter ²⁾	DN 125 PN 10	
14	Bourdon vacuum gauge	G 1/2" M	
15	Ball valve	G 1/2" M/F	Brass, nickered/Aluminium

¹⁾ incl. O-ring

²⁾ See "Dust Filters F (Suction Side)" for other options

M = Outside thread

F = Inside thread

Ordering Information

Connection Fittings

SV 1200

	Part No.
Item Description	
1 PVC tubing	711 18 329
2 Hose connection	711 18 363
3 Coupling	711 18 343
4 Flange with tubulation ¹⁾	711 18 355
5 Adaptor for Roots pump RUVAC 2001	953 37
RUVAC 3001	953 38
RUVAC WH 4400/7000	953 3WH
6 Adaptor flange	711 18 117
7 Collar flange	711 18 386
8 Electropneumatic valve	715 69 202
9 Hose connection	711 18 017
10 O-ring 165 x 5	712 42 902
165 x 5	712 42 912
11 Centering ring ¹⁾	711 18 396
12 Elbow 90°	711 18 287
13 Dust filter ²⁾ with paper cartridge	951 75
with activated charcoal cartridge	711 27 142
with metal cartridge	711 27 143
with polyester filter cartridge	711 27 144
14 Bourdon vacuum gauge	951 92
15 Ball valve	711 30 113

Special versions for oxygen applications are available upon request

¹⁾ incl. O-ring

²⁾ See "Dust Filters F (Suction Side)" for other options

Only available for purchase in North and South America

60 Hz Curves

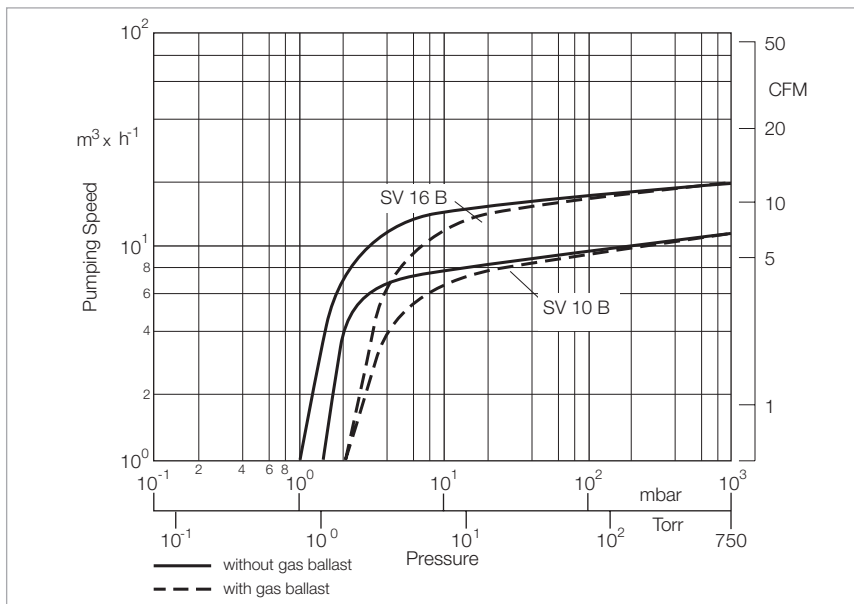

Pumping speed characteristics for the SOGEVAC SV 10 B and SV 16 B at 60 Hz

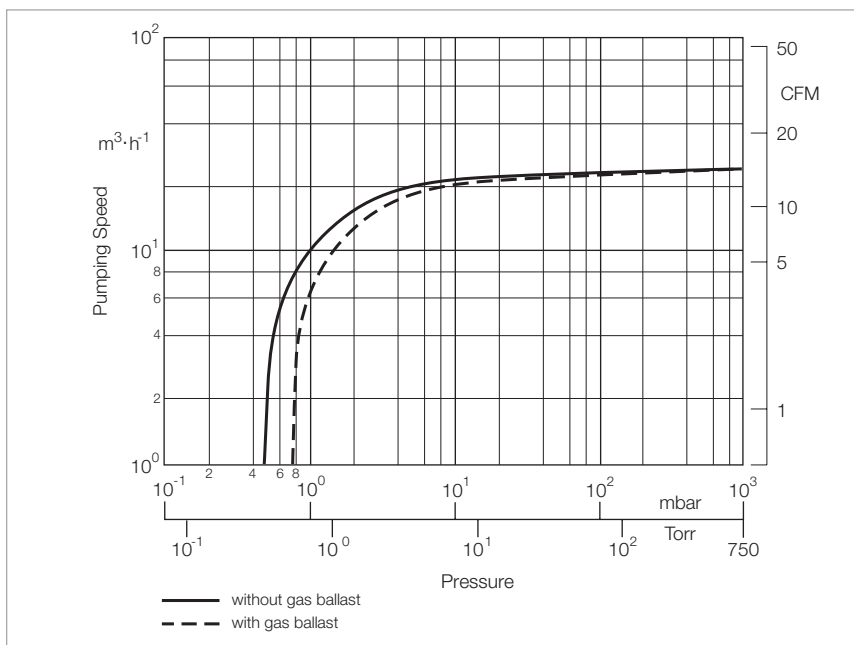

Pumping speed characteristics for the SOGEVAC SV 25 B at 60 Hz

Only available for purchase in North and South America

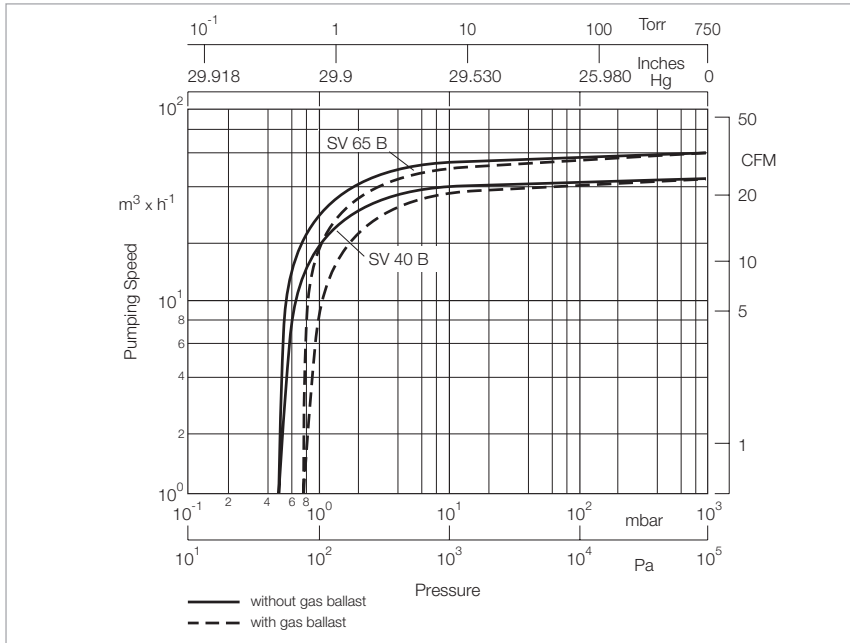

Pumping speed characteristics for the SOGEVAC SV 40 B and SV 65 B at 60 Hz

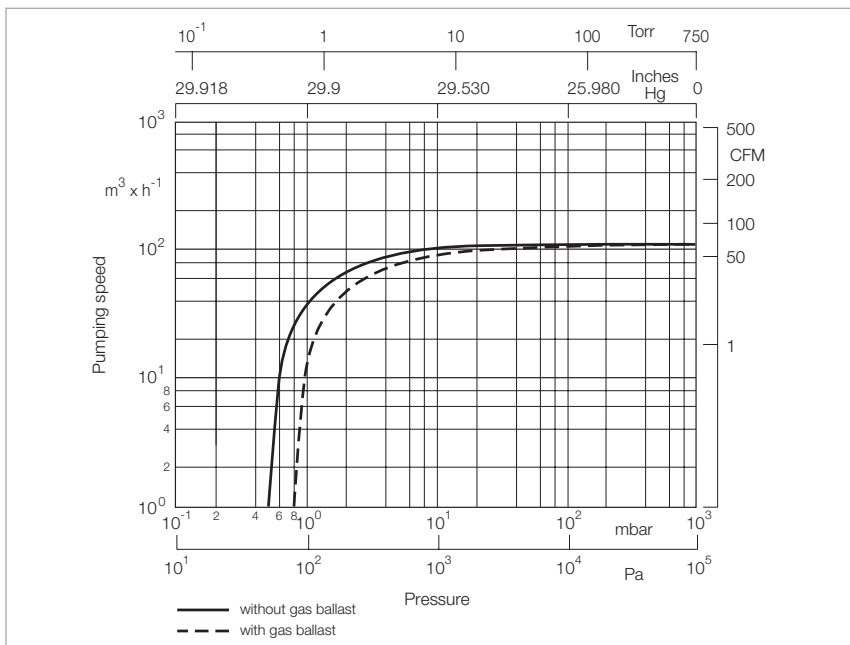

Pumping speed characteristics for the SOGEVAC SV 100 B at 60 Hz

Only available for purchase in North and South America

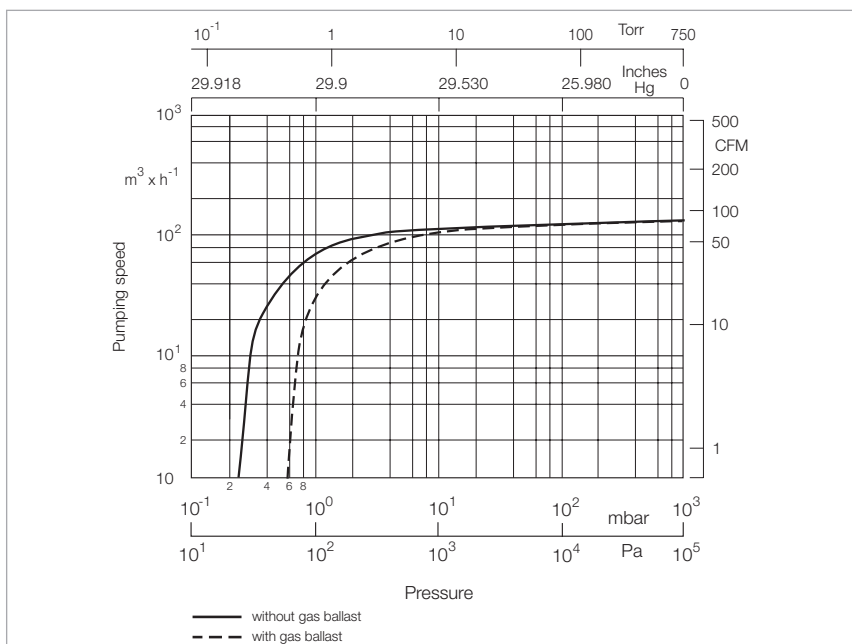

Pumping speed characteristics for the SOGEVAC SV 120 B at 60 Hz

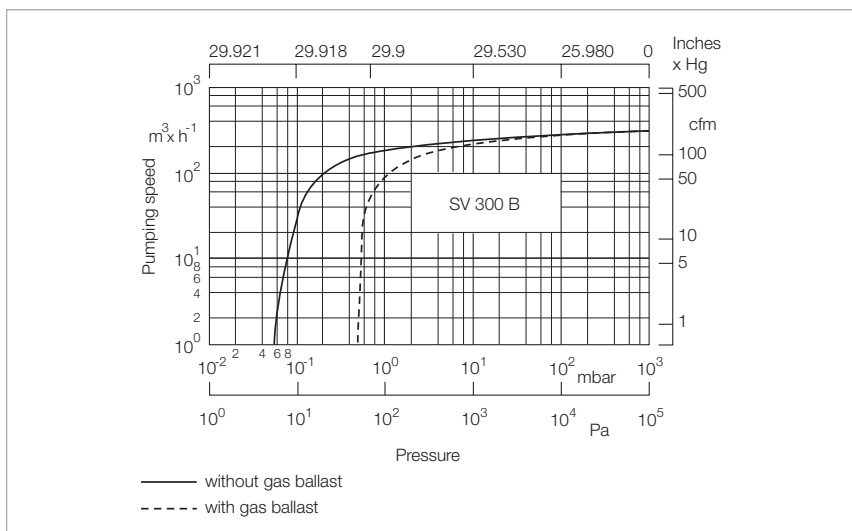

Pumping speed characteristics for the SOGEVAC SV 300 B at 60 Hz

Only available for purchase in North and South America

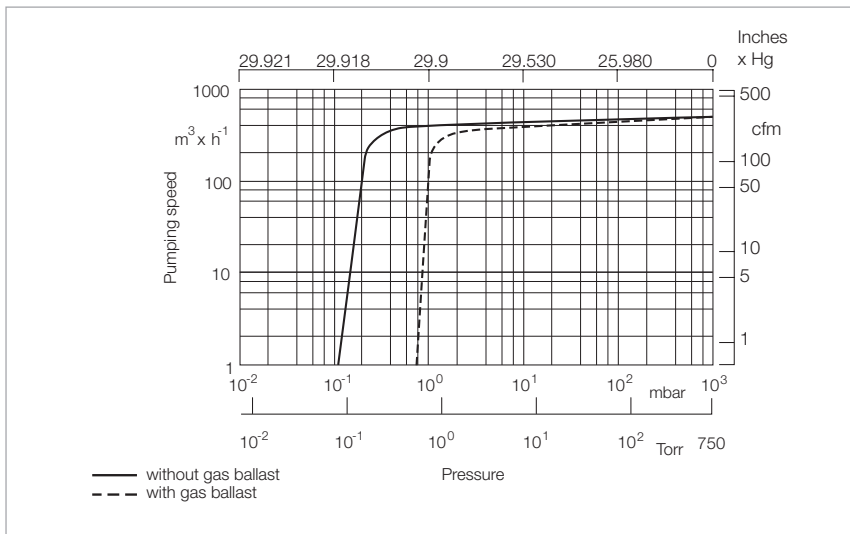

Pumping speed characteristics of the SOGEVAC SV 470 B(F) and 570 B(F) at 60 Hz operation

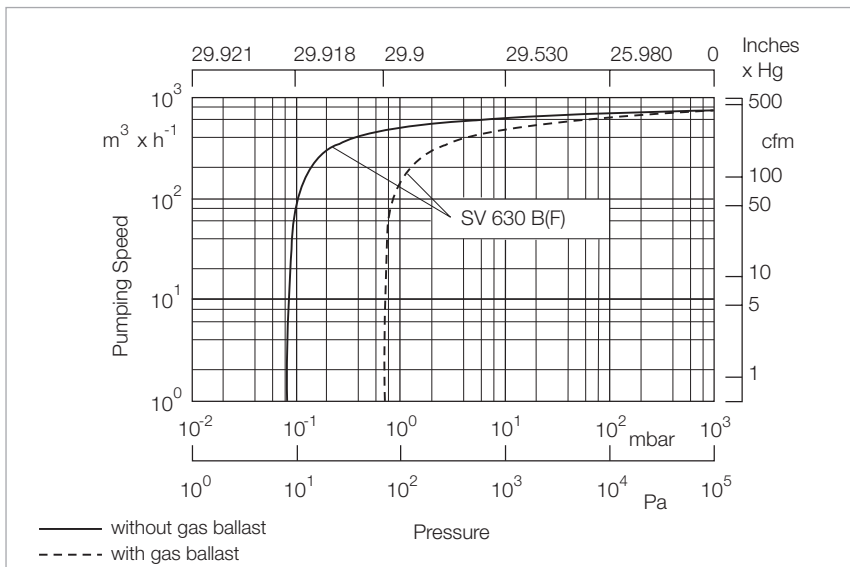

Pumping speed characteristics for the SOGEVAC SV 630 B(F) at 60 Hz

Only available for purchase in North and South America

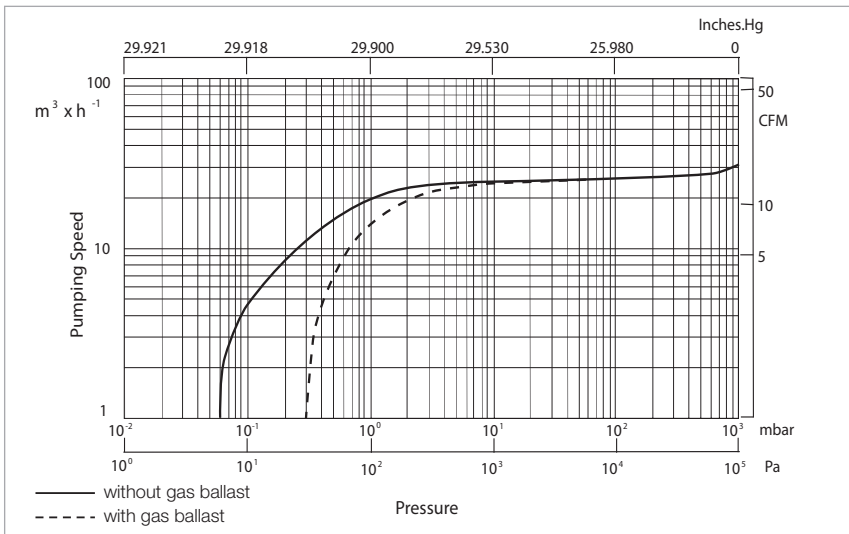

Pumping speed characteristics for the SOGEVAC SV 28 BI at 60 Hz

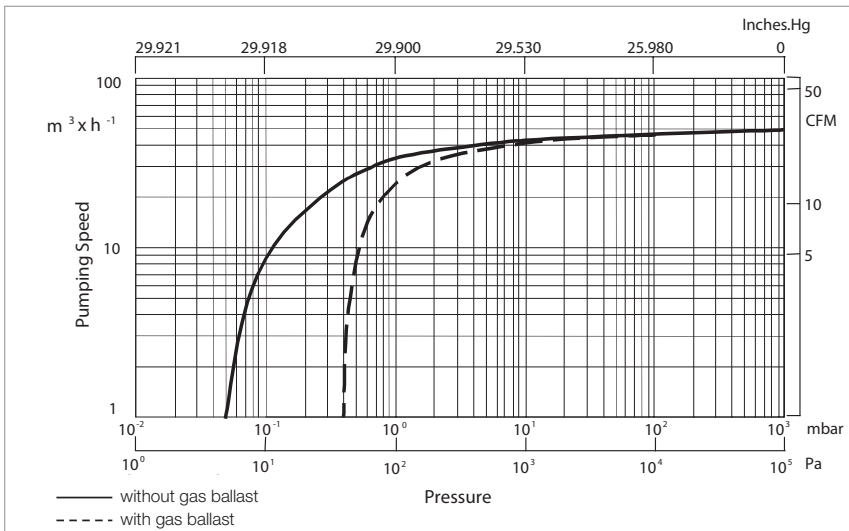

Pumping speed characteristics for the SOGEVAC SV 40 BI at 60 Hz

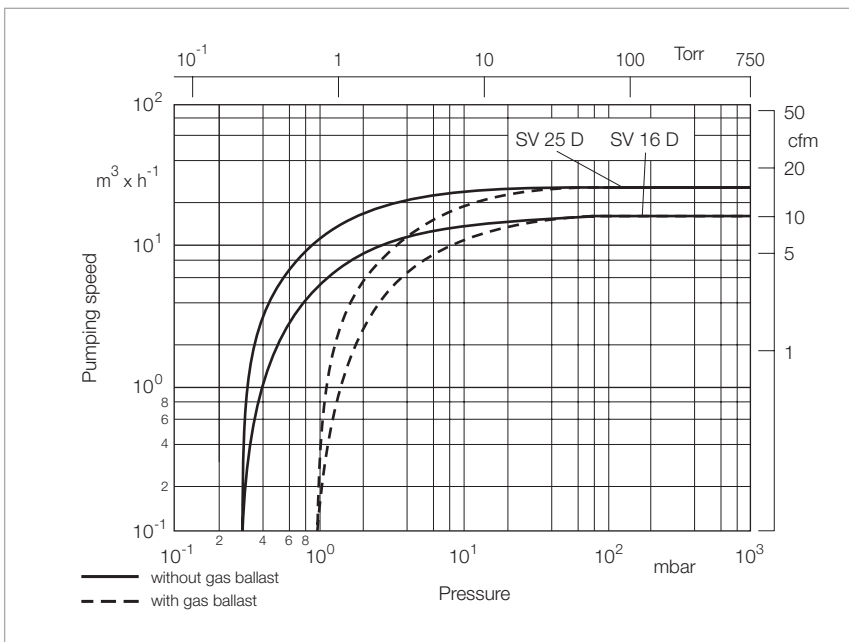

Pumping speed characteristics for the SOGEVAC SV 16 D and SV 25 D at 60 Hz

Only available for purchase in North and South America

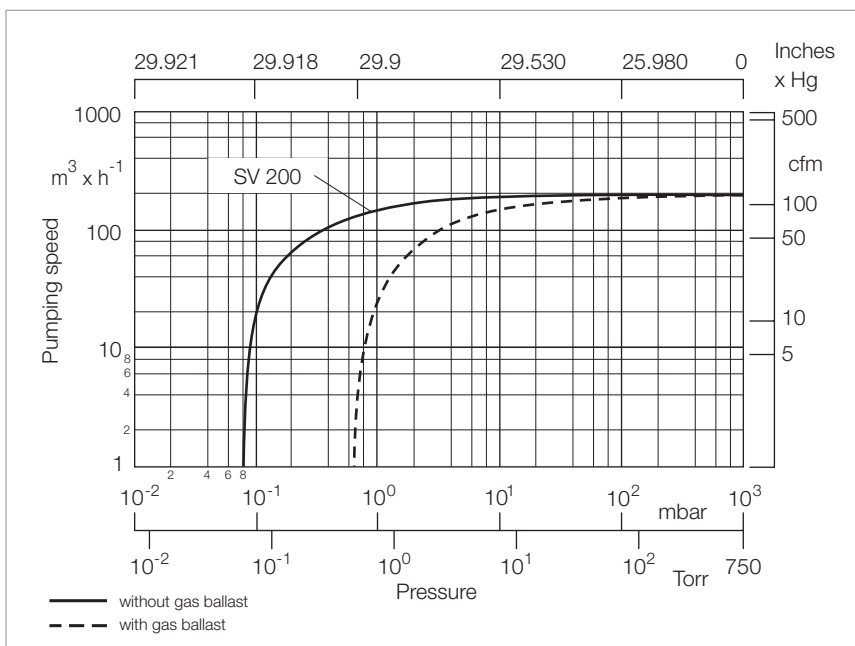

Pumping speed characteristics for the SOGEVAC SV 200 at 60 Hz

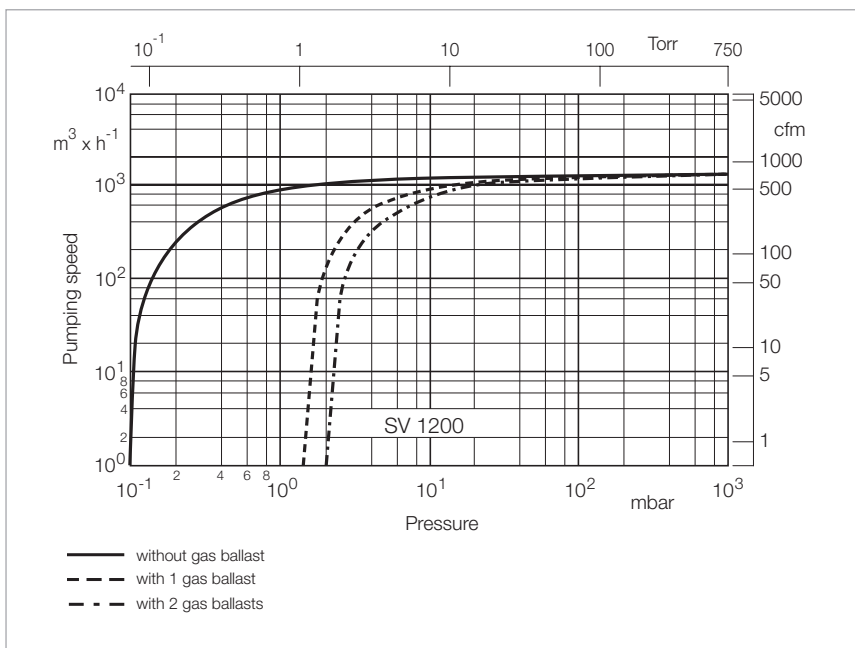

Pumping speed characteristics for the SOGEVAC SV 1200 at 60 Hz

Only available for purchase in North and South America

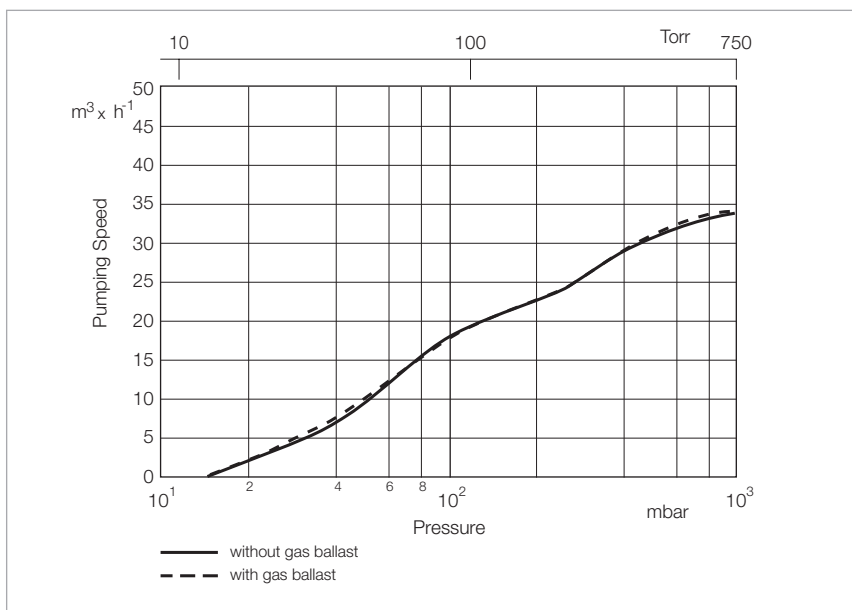

Pumping speed characteristics of the SOGEVAC SV 40 ATEX at 60 Hz for gases of the material group IIB and H_2

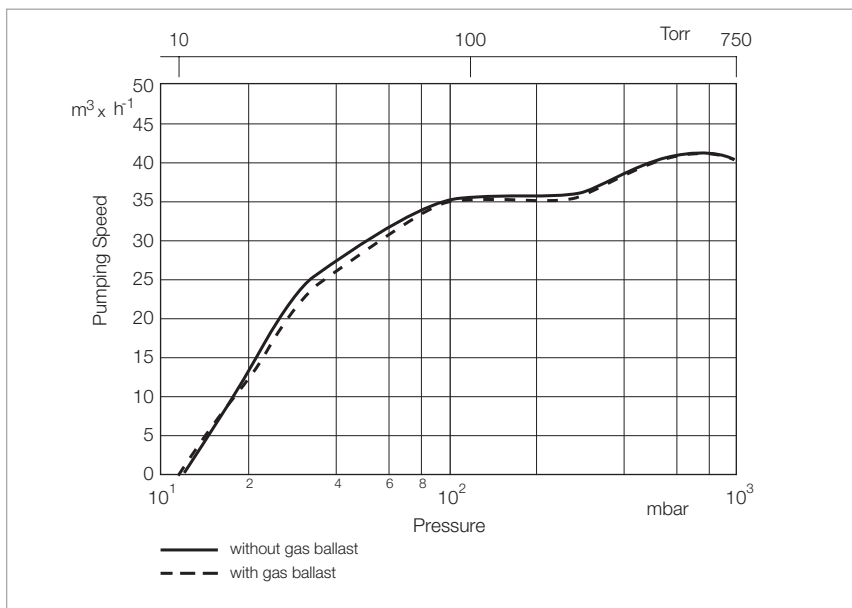

Pumping speed characteristics of the SOGEVAC SV 40 ATEX at 60 Hz for gases of the material group IIA

Only available for purchase in North and South America

Combination Filter

Vacuum Pump Inlet Filter



Combination filter

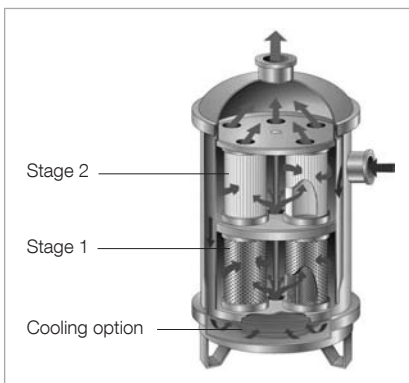

Combination filter: cutaway view

The combination filter is a high efficiency vacuum pump inlet filter designed specifically to condense, absorb, and neutralize process byproducts generated from vacuum applications in the chemical and pharmaceutical industries.



Cooling Option for combination filter

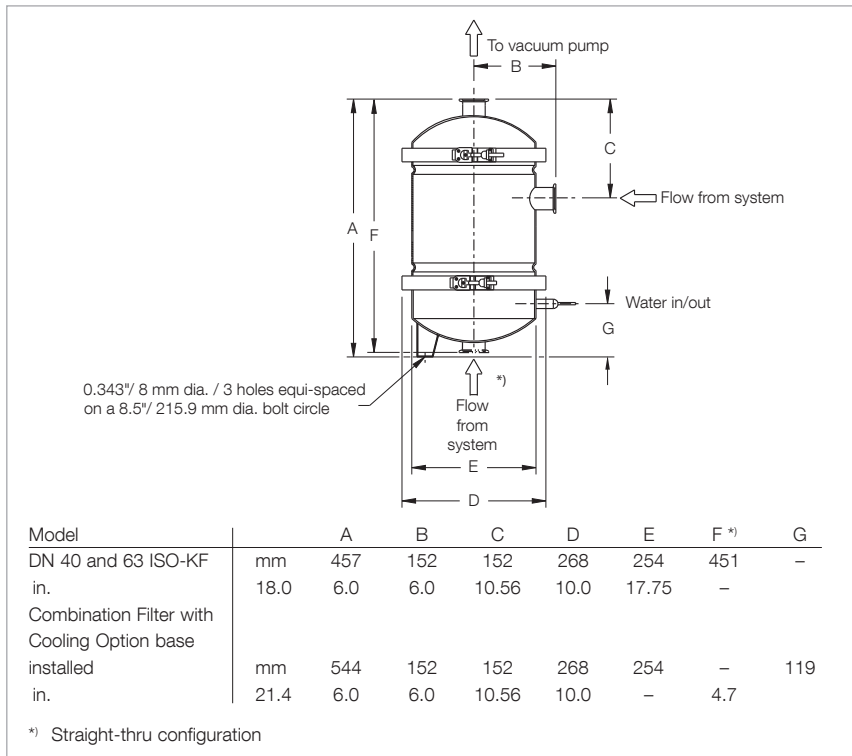

Dimensional drawing for the combination filter

Advantages to the User

- All stainless steel construction with-stands corrosive environments
- Modular design allows for numerous configurations and easy servicing
- Stacking modules available for increased capacity
- Optional drain port for solvent draining and reclamation
- Customizable absorption/neutralization stages for optimal efficiency
- Processes such as distillation, drying, degassing, central lab vacuum protection
- Cooling option: Large cooled surface area for condensing of solvents, acids and water vapor

Specifications

- Construction in stainless steel 304
- Upper and lower seals in Buna N and Viton

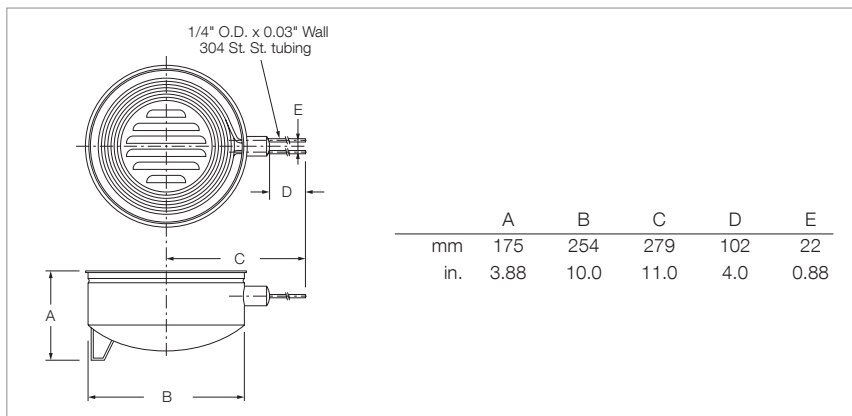

Dimensional drawing for the combination filter Cooling Option

Ordering Information**Combination Filter****DN 40 ISO-KF****DN 63 ISO-K**

	Part No.	Part No.
Combination filter 5 filter elements in stage 1 and 5 elements in stage 2 (elements not included)	180497V	180499V
straight-thru configuration, same as above except inlet on bottom	180498V	-
Stacking modules includes 2 stages (5 elements ea.), 11.25" (286 mm) tall, all attachment hardware included (filter elements not included)	180500V	180500V
Cooling Option base, 0.5 - 1.0 GPM (2 - 4 LPM) water flow recommended	180501V	180501V

Ordering Information**Filter Elements**

	Part No.
Copper gauze	180502V
Stainless steel gauze	180503V
Molecular sieve	180504V
Porous mixture of sodium hydroxide and potassium hydroxide	180505V
Activated charcoal	180506V
Pleated polypropylene 2 micron (99% efficient)	180507V
Pleated polypropylene 5 micron (99% efficient)	180508V
Pleated polypropylene 20 micron (99% efficient)	180509V

Ordering Information**Adapters (Stainless Steel)**

	Part No.
DN 40 ISO-KF to 1 1/4" NPT (male)	899 627
DN 40 ISO-KF to 2" NPT (male)	899 629
DN 63 ISO-K to 2" NPT (male)	721 03 040

Products

Oil-sealed Screw Vacuum Pumps VACUBE VQ 400 i to VQ 1650 iCH



Screw vacuum pump VACUBE VQ 1250 iCH

VACUBE is a new generation of intelligent, single-stage, oil-sealed screw vacuum pumps with Variable Speed Drive (VSD) technology.

VACUBE generates vacuum on demand. All pumps are controlled and maintained by an internal controller. The systems offer superior performance for a wide range of rough vacuum applications.

Models

i – model

Ideal for standard vapor free applications as needed in central vacuum systems for holding, lifting and moving of parts and components.

iH – model

This variant is best suited for applications with high water vapor ingress. The high water vapor tolerance level makes the iH – model best suited for the humid applications.

iC – model

The iC – VACUBE variant is specifically designed to support the special needs in short cycling applications, as for example common in vacuum packaging or assembly lines for electronic equipment.

iCH – model

The combination of „iH“ and „iC“ offers high water vapor tolerance and the short cycling ability.

Advantage to the User

- **Pump efficiency**
 - Variable speed drive (VSD)
 - Internal controller
- **Power demand**
 - Sustainable power saving due to on-demand vacuum generation
- **Work space environment**
 - Ultra-high oil retention system
 - Quiet operation, noise level bench mark
 - Small footprint – pallet size dimensions*
(*up to 950 m³/h speed)
 - “Plug and play” system set up
- **Sustainable productivity**
 - Programable operation modes
 - Long maintenance intervals

Typical Applications

- **Holding, lifting and moving**
 - Print & Paper
 - Packaging
 - Electronic manufacturing
- **Woodworking**
 - Li-Ion cell manufacturing
 - Glass manufacturing
- **Forming and shaping**
 - Plastics (e.g. bath tubs, shower trays, white goods internals)
 - Packaging materials (e.g. thermoformed parts)
 - Glass items such as bottles and windscreens
 - Wood lamination
- **Preserving**
 - Meat packaging (skin, modified atmosphere packaging MAP)
 - Poultry packaging
 - Canning
 - Food freeze drying
- **Dehumidification**
 - Vacuum cooling
 - Roof tile and brick manufacture
 - Pipeline drying
- **Special demands**
 - Altitude testing
 - Special evacuation duties
 - Coating
 - Clean environments



Integrated Controller / Monitoring System

The VACUBE controller maintains the pressure within programmable limits by automatically adapting the motor speed. A number of programmable settings, e.g. the setpoint, the minimum stop time and the maximum number of

motor starts and several other parameters are hereby taken into account.

The controller stops the vacuum pump whenever possible to reduce the power consumption and restarts it automatically when the pressure increases.

For H version pumps, the pump is equipped with a purge cycle which prevents and removes condensed water in the sealing oil.

The controller can be operated intuitively. A comfortable 3,5" – Color Display is used as graphic user interface to call up menus or to input customized settings easily. LED's inform about maintenance and service demands.

Multiple controllers can be linked with each other.

Further features:

- Set point pressure selection
- Gas ballast on/off
- Displays:
 - Pressures (inlet, discharge)
 - Temperatures
 - Alarms and warnings
 - Counters (e.g. running hours, pump starts, etc.)
- Week timer function
- Language and unit selection

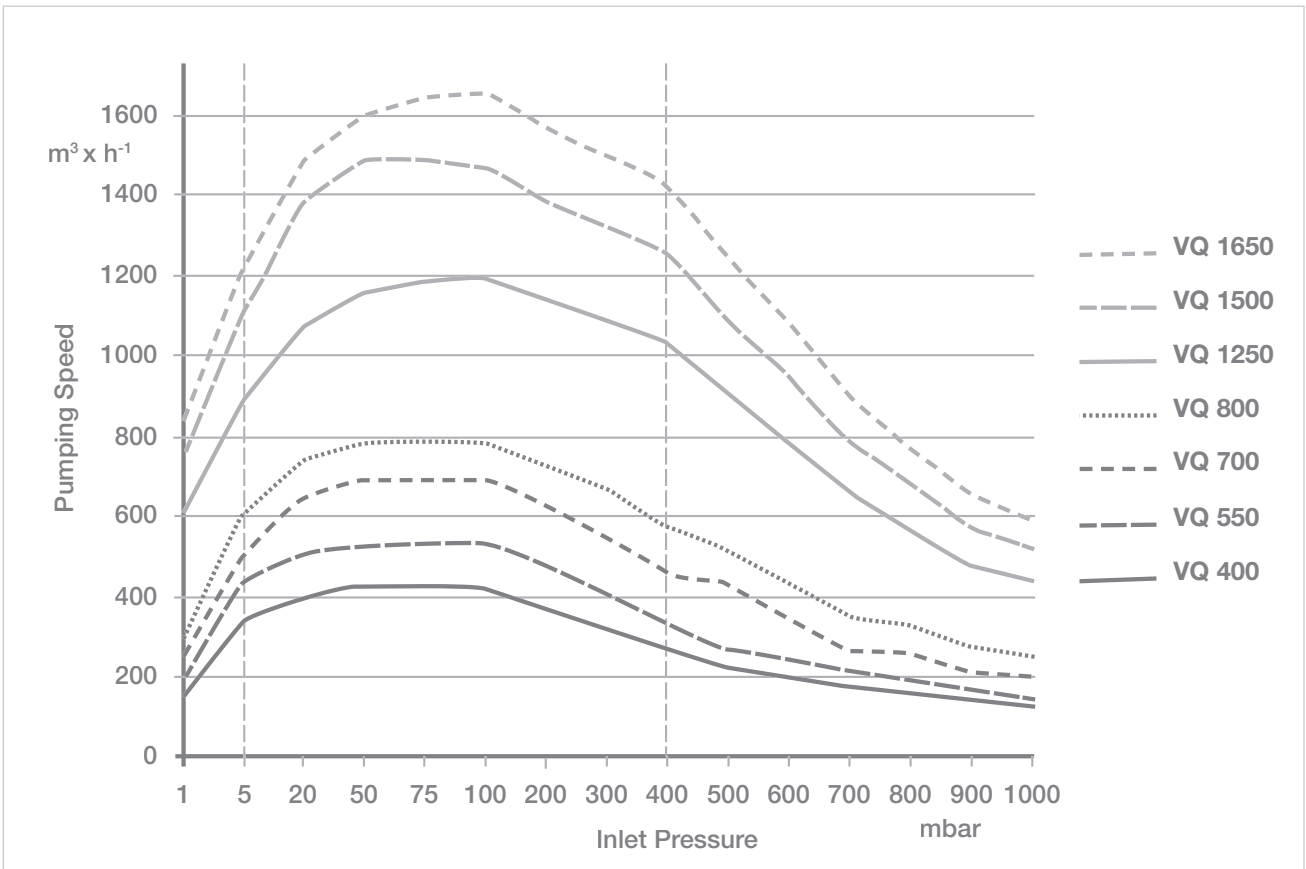

Pumping speed characteristics

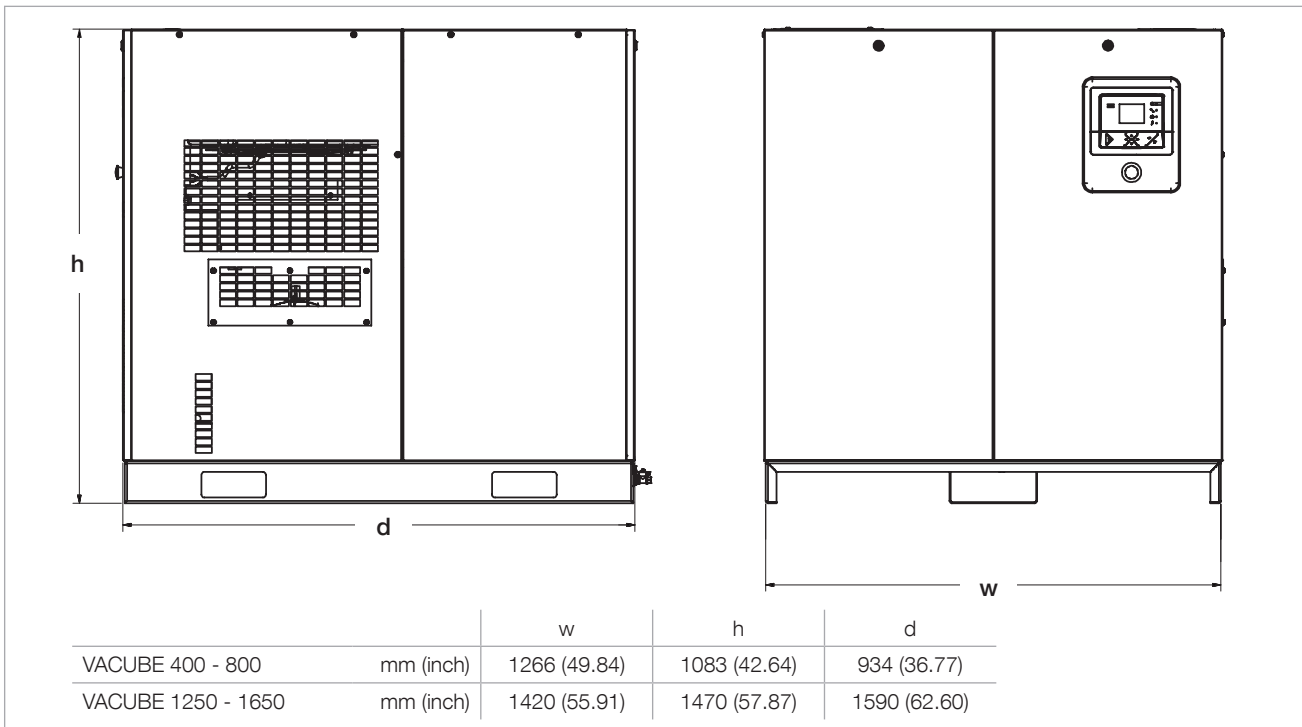

Dimensional drawing VACUBE

Technical Data

VACUBE

VQ 400 VQ 550 VQ 700 VQ 800 VQ 1250 VQ 1500 VQ 1650

Max. eff. pumping speed	m³/h / cfm	420 / 247	530 / 310	700 / 412	790 / 465	1250 / 736	1490 / 877	1620 / 955
Ultimate pressure	mbar / Torr	0.35 / 0.26						
Motorshaft power	kW / hp	5.5 / 7.5	7.5 / 10	11 / 15	15 / 20	22 / 29	30 / 40	37 / 50
Noise level	dB(A)	51 - 65	51 - 65	51 - 73	51 - 76	65 - 75	65 - 75	65 - 80
Ambient temperature	°C / °F	0 - 46 / 32 - 115						
Weight	kg / lbs	500 / 1102	500 / 1102	510 / 1125	520 / 1147	1058 / 2333	1058 / 2333	1073 / 2366
Motor protection class	IP	54						
Supply voltages*		380 - 460V, 3ph, 50/60Hz						

* other voltages available on request

Ordering Information**VACUBE**

	Part No.
VACUBE VQ 400 i	177040V01
VACUBE VQ 400 iH	177040V10
VACUBE VQ 550 i	177055V01
VACUBE VQ 550 iC	177055V05
VACUBE VQ 550 iH	177055V10
VACUBE VQ 550 iCH	177055V15
VACUBE VQ 700 i	177070V01
VACUBE VQ 700 iC	177070V05
VACUBE VQ 700 iH	177070V10
VACUBE VQ 700 iCH	177070V15
VACUBE VQ 800 i	177080V01
VACUBE VQ 800 iC	177080V05
VACUBE VQ 800 iH	177080V10
VACUBE VQ 800 iCH	177080V15
VACUBE VQ 1250 i	177125V01
VACUBE VQ 1250 iH	177125V10
VACUBE VQ 1500 i	177150V01
VACUBE VQ 1500 iC	177150V05
VACUBE VQ 1500 iH	177150V10
VACUBE VQ 1500 iCH	177150V15
VACUBE VQ 1650 i	177165V01
VACUBE VQ 1650 iC	177165V05
VACUBE VQ 1650 iH	177165V10
VACUBE VQ 1650 iCH	177165V15

 **Leybold**
avrorra-arm.ru
+7 (495) 956-62-18