



avrorarm.ru
+7 (495) 956-62-18

Top performance when the going gets tough

The Alfa Laval DuroShell plate-and-shell heat exchanger



DuroShell – plate-and-shell made tougher

Alfa Laval DuroShell is a specially engineered plate-and-shell heat exchanger ideal for demanding duties and corrosive media. Able to withstand fatigue even at high temperatures and pressures, it outperforms not only traditional heat exchangers, but also other plate-and-shells.

As flexible as it is strong

DuroShell creates new possibilities through its compactness, efficiency and exceptional resistance to fatigue. Able to work with liquids, gases and two-phase mixtures, it stands out among heat exchangers in its duty range. DuroShell handles pressures up to 100 barg (1450 psig) in compliance with PED and ASME, and temperatures as high as 450 °C (842 °F).

Built for your application

DuroShell is fully welded and gasket-free, with internal features that make it still more robust. Plates are available in 316L stainless steel, while the pressure vessel itself can be built in 316L stainless steel or carbon steel. Three different sizes are possible, with heat transfer surfaces ranging 2–235 m² (21.5–2530 ft²) in area.



DuroShell RollerCoaster
Robust and efficient performance.



DuroShell PowerPack
Optimized flow distribution and fatigue resistance.

Learn more at www.alfalaval.com/duroshell



Plate-and-shell benefits made better

- More uptime and longer life due to greater fatigue resistance
- Higher operating pressures thanks to robust, patented construction
- Operational gains created by 15–20 % higher thermal efficiency
- Installation savings through even more compact, lightweight design
- Greater reliability as a result of closed, fully welded construction

How it works

Revolutionary technology

DuroShell is a plate-and-shell heat exchanger, but one with a unique internal design. Its laser-welded plate pack is comprised of cut-wing plates, pressed with a patented roller coaster pattern that resists plate fatigue. The plate-side distribution tubes run through the plate pack itself, which further increase its strength.

The plates' roller coaster pattern improves thermal efficiency by maximizing turbulence and minimizing fouling. In addition, the cut-wing plate design creates an open channel on each side of the shell interior. This allows multi-pass arrangements that further benefit efficiency.

Resistance to fatigue

DuroShell offers superior resistance to thermal and pressure fatigue, thus withstanding large variations in process conditions. Unlike the corrugated plates of conventional plate-and-shell heat exchangers, which tend to expand in just one dimension, DuroShell plates expand evenly in all directions thanks to their patented roller coaster pattern. This means that no weak spots arise under stress.

Fatigue resistance is further improved by the distribution tubes running through the plate pack, as well as by the laser welding used throughout. Lasers create the most accurate weld while placing the least heat stress on surrounding material.

Optimized flow

DuroShell operates with one media on the plate side and the other on the shell side, both of which can be rated up to the full 100 barg (1450 psig). In a single-pass configuration, the heat exchanger works in pure cross-flow. In a multi-pass arrangement, the flow is equivalent to a global counter-current configuration.

The distribution tubes that extend through the plate pack ensure even distribution of media across the heat transfer surface. Since the nozzles on the shell side are independent from those on the plate side, DuroShell is ideal for asymmetric flow duties.

Less maintenance

Like all plate-and-shells, DuroShell involves far less maintenance than labour-intensive shell-and-tube heat exchangers. Complicated manual cleaning is replaced by backflushing, or ideally by simple Cleaning-in-Place.

In fact, DuroShell involves less maintenance than other plate-and-shells. The plates' roller coaster pattern creates high turbulence at all media velocities, which prevents fouling even with slightly more difficult media. There is no need for the heat exchanger to be openable for cleaning, which would introduce design weaknesses and increase the risk of failure.

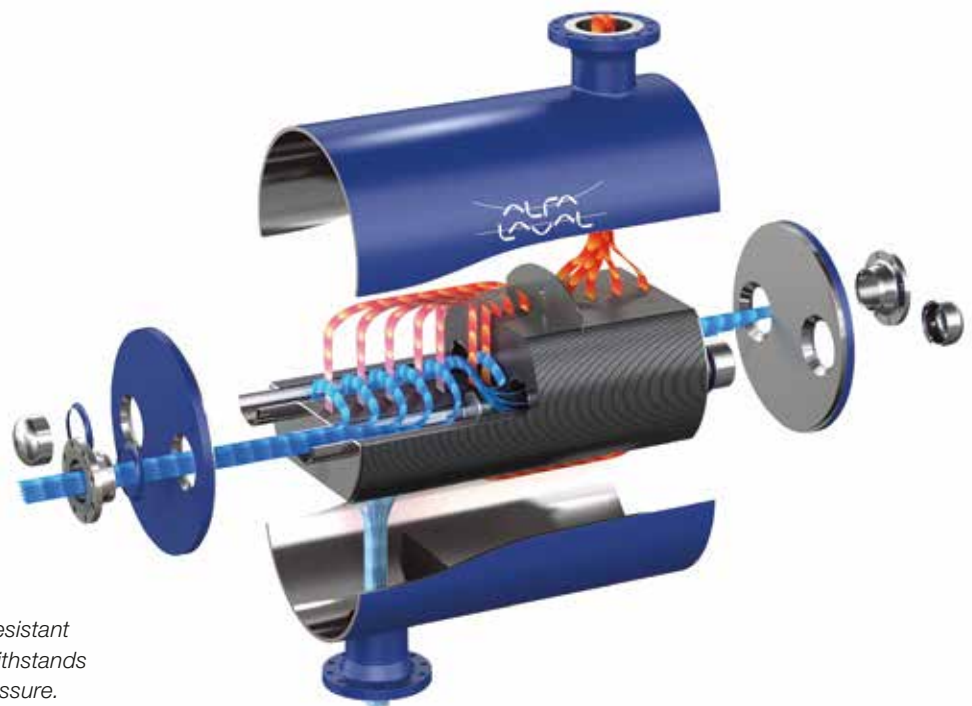

Robust, fully welded and highly resistant to fatigue, Alfa Laval DuroShell withstands variations in temperature and pressure.

Designed for demanding duties

Alfa Laval DuroShell is the smartest solution for a wide range of duties traditionally occupied by shell-and-tube heat exchangers.

Ready to be challenged

DuroShell handles the duties gasketed plate heat exchangers are unable to manage. In most cases, these are the ones typically left to shell-and-tube solutions, such as working with:

- Two-phase mixtures in addition to liquids and gases
- Temperatures as high as 450 °C (842 °F)
- Pressures up to 100 barg (1450 psig)

Not only does DuroShell surpass shell-and-tubes in these duties, it delivers performance and reliability well beyond those of conventional plate-and-shell alternatives.

Power applications

- Boiler feed water preheaters
- District heating condensers
- Evaporators, reboilers and condensers in ORC applications
- Fuel gas heaters
- Gland steam condensers
- Other auxiliary applications such as boiler blowdown coolers



Petrochemical applications

- Batch reactor heaters/coolers
- Interchangers – feed/effluent exchangers
- Overhead condensers for distillation columns
- Steam-driven feed preheater
- Liquid-driven reboilers
- Mechanically demanding high-pressure applications requiring a small footprint

Why make the change from shell-and-tubes?

Plate-and-shell heat exchangers offer a wide range of advantages over traditional shell-and-tubes, such as:

- Higher thermal efficiency leading to energy savings and new possibilities
- High turbulence that reduces fouling and the need for maintenance

- Compact design that allows capacity to be added in limited space
- Lower capital investment

For these reasons and others, plate-and-shells are now well established in industry. But their full potential has only been realized with Alfa Laval DuroShell. DuroShell offers the clearest reasons for making the conversion from shell-and-tubes – and is worth considering even if you have already made the switch.

Alfa Laval DuroShell's cut-wing plate design allows fluid distribution and multi-pass arrangements on the shell side.

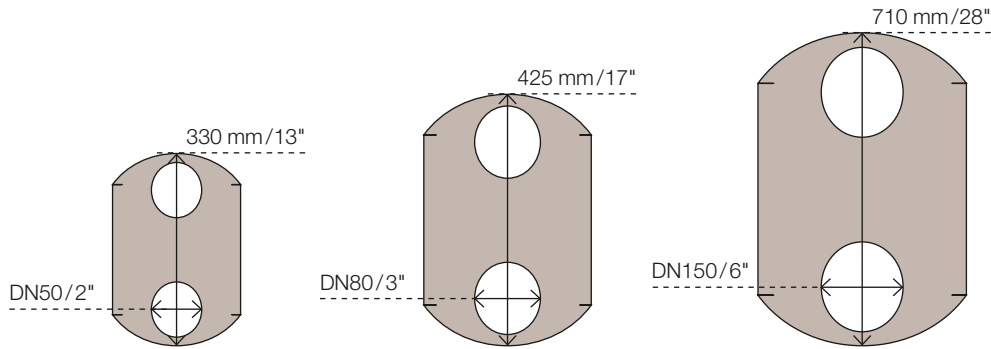

Technical specifications

Design pressure

| | |
|--------|--------------------------------|
| CE/PED | Vacuum to 100 barg (1450 psig) |
| ASME | Vacuum to 100 barg (1450 psig) |
| SELO | Vacuum to 99 barg (1435 psig) |

Design temperature

| | |
|-----------------------------|-----------------------------------|
| Carbon steel shell: | -45°C to 450°C (-49°F to 842°F) |
| 316L stainless steel shell: | -160°C to 350°C (-256°F to 662°F) |

Maximum heat transfer surface

| | |
|-------------|--|
| DuroShell S | 15 m ² (161 ft ²) |
| DuroShell M | 56 m ² (603 ft ²) |
| DuroShell L | 235 m ² (2530 ft ²) |

Standard connections

| | Plate side | Shell side |
|-------------|-------------|-------------------|
| DuroShell S | 50 mm (2") | 25–200 mm (1–8") |
| DuroShell M | 80 mm (3") | 25–300 mm (1–12") |
| DuroShell L | 150 mm (6") | 25–500 mm (1–20") |

Pressure rating

| |
|--------------------------|
| PN16, PN40 & PN100 |
| ASME Class 150, 300, 600 |

Standard materials

| | |
|--------------------------|--|
| Plates | 316L stainless steel |
| Shell/covers/ nozzles | Carbon steel gr60 (painted) or 316L stainless steel (not painted) |

Specific to your duty

DuroShell is the result of Alfa Laval's extensive thermal expertise. We tailor it specifically to your desired application, creating an exact fit for your process.

We can promise this as the world's leading provider of heat transfer solutions. Alfa Laval offers not just plate-and-shell heat exchangers, but a comprehensive range of heat exchanger types. The solution we recommend is always based on a specific duty, which ensures that you get the most appropriate technology and the best long-term economy.

Other Alfa Laval heat exchangers

Besides gasketed plate heat exchangers, Alfa Laval solutions include:

- **Alfa Laval Compabloc**

Tailor-made Compabloc has a welded plate pack that can handle some of the same pressure duties as DuroShell. The pack is enclosed by removable panels, which makes it a potential alternative where opening is absolutely necessary.



- **Alfa Laval spiral heat exchangers**

Spiral heat exchangers are welded, openable and specially designed for dirty process duties with a high degree of fouling. Their inherent self-cleaning features safeguard uptime and ensure fast service turnaround.



Quality that keeps on going

Alfa Laval DuroShell is specifically designed for self-sufficient performance. By getting the engineering right from the beginning, we create a solution that needs virtually no maintenance.



Lasting innovation

Everything about DuroShell is designed to keep it in operation, so that your process stays uninterrupted. From its exceptional fatigue resistance to the anti-fouling properties of its roller coaster plate pattern, it applies all the lessons learned in decades of heat transfer experience.

We then size and configure DuroShell for your specific duty. The result needs far less attention than a traditional shell-and-tube, and it lasts far longer than any conventional plate-and-shell.

Ensuring performance

As a comprehensive supplier of process equipment, Alfa Laval has an equally comprehensive service offering. But when it comes to DuroShell, two services are all you need:

- **Cleaning-In-Place (CIP)**
CIP keeps it clean and maintains peak thermal performance
- **Alfa Laval Performance Audit**
Performance Audit checks the exact level of thermal efficiency and can be used to determine if any maintenance is needed, ensuring that your uptime is never at risk.

The closed approach is best

Many plate-and-shell heat exchangers are presented as openable solutions, which might seem like an advantage. But while opening allows visual inspection and superficial cleaning, it also means risk.

Creating an openable plate-and-shell heat exchanger introduces design weaknesses that can lead to problems down the road. While acceptable for lighter duties, an openable heat exchanger can never offer the same lifetime or pressure performance as a fully welded solution like Alfa Laval DuroShell.

Reboiler in propane recovery

A Swedish producer of polyethylene plastic uses one DuroShell and two AlfaNova heat exchangers in its system for recovering propane in ethylene cracker off-gases for reuse in the polyethylene production process. The DuroShell acts as a reboiler, performing well thanks to its high

vaporization rate, compact size and high-pressure durability.

The possibility of crossing temperatures in a single unit means a DuroShell can perform heating and vaporization duties using lower grade steam than a traditional shell-and-tube heat exchanger.



Power plant steam condenser

Space restrictions were a major concern for a French power plant evaluating heat exchangers for use as a steam condenser. The company needed a solution with a minimal footprint that could increase the efficiency of its steam turbine.

DuroShell offered the perfect choice. Because it can both condense steam and subcool the condensate in the same unit, the plant was able to save a tremendous amount of space.

Reactor temperature controller

A green chemicals plant in France endured longstanding problems with a heat exchanger used for controlling reactor temperature. Sudden steam injections in the reactor resulted in rapid temperature and pressure changes, which in turn caused fatigue in the heat exchanger. The company's engineers decided to replace the failed heat exchanger with a DuroShell.

With its unique design, DuroShell secures fatigue resistance up to five times higher than other plate-and-shell heat exchangers. The high thermal transfer and low hold-up volume let DuroShell regulate temperatures quickly and accurately, which is important for both product quality and process yield.



Jacket cooler/heater

Significant temperature and pressure changes caused frequent fatigue failure for the jacket heater/cooler used by a specialty chemicals manufacturing plant in Switzerland. By installing DuroShell, the plant has doubled uptime and cut maintenance time in half, thanks to DuroShell's improved thermal fit combined with its exceptionally fatigue resistant design.

DuroShell offers more than just fatigue resistance when operating as a jacket cooler/heater. With its low hold-up volume, it provides fast and accurate temperature control to maximize product quality and yield. The ability to operate with crossing temperatures also minimizes costs for steam or cooling water.

Alfa Laval in brief

Alfa Laval is a leading global provider of specialized products and engineered solutions.

Our equipment, systems and services are dedicated to helping customers to optimize the performance of their processes. Time and time again.

We help our customers to heat, cool, separate and transport products such as oil, water, chemicals, beverages, foodstuff, starch and pharmaceuticals.

Our worldwide organization works closely with customers in almost 100 countries to help them stay ahead.

avrrora-arm.ru
+7 (495) 956-62-18

