

## 2/2-way Solenoid Valve for combustible gases, 0–150mbar

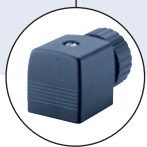

Type 0293 can be combined with...



### Type 2508

Cable plug

Type 293 switches without pressure change from zero bar. The direct acting solenoid feed valve is delivered with circuit function A. It is normally closed. Upon switching the magnetic core is tightened against the spring and the valve opens. A filter is built-in to the inlet. The valve is especially good for switching low-pressure combustible gases.

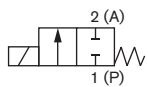

Servo-assisted 2/2-way valve, direct acting, normally closed

- Direct acting (normally closed) Solenoid Valve
- Vibration resistant screw block coil construction
- Seal and diaphragm according to DIN EN 549
- Integrated filter

Technical data	
<b>Body material</b>	Brass
<b>Inner part valve</b>	1.4105:1.4571
<b>Seal materials</b>	NBR
<b>Medium for NBR</b>	Flammable liquids such as gas, natural gas, liquid petroleum gas (LPG), acetylene, hydrogen
<b>Medium temperature for NBR</b>	-15 to +60 °C
<b>Ambient temperature.</b>	-15 to +60 °C
<b>Ambient</b>	Also open air (open cover recommended)
<b>Port connection</b>	Threaded ports G 3/4 and G1
<b>Special features</b>	Sieve in inlet
<b>Operating voltages</b>	230 V/50 Hz 230 V/UC
<b>Voltage tolerance</b>	±10%
<b>Cycling rate</b>	ca. 100-150/min for AC ca. 10-15/min for UC
<b>Duty cycle</b>	100% continuous rating
<b>Electr. Connection</b>	Cable plug for Ø 7 mm cable (included in delivery)
<b>Protection class</b>	IP 65 with cable plug
<b>DVGW Approval</b>	Group 2, class A
<b>Fulfilled standards</b>	DIN EN 161
<b>Installation</b>	As required, preferably with actuator upright

## Further Technical Data

Orifice [mm]	Port Connection	Kv-value water [m <sup>3</sup> /h]	Pressure range [mbar] [	Response times		Power consumption				Weight [kg]
				Opening [ms]	Closing [ms]	Inrush AC [VA]	UC [W]	[VA] AC [VA/W]	UC [W]	
20	G 3/4	5.0	0 - 150	130	120	100	100	25/16	9	1.2
25	G 1	10.0	0 - 150	up to 250	up to 150	up to 120			1.7	

**Flowrate: Kv value water [m<sup>3</sup>/h]**

measured at +20°C, 1 bar pressure at valve inlet and free outlet

**Pressure values [bar]**

Overpressure with respect to atmospheric pressure

**Measured at valve outlet at 6 bar and +20 °C**

Opening	Pressure rise 0 to 90%,
Closing	pressure relief 100 to 10%

## Dimensions [mm] (other versions on request)

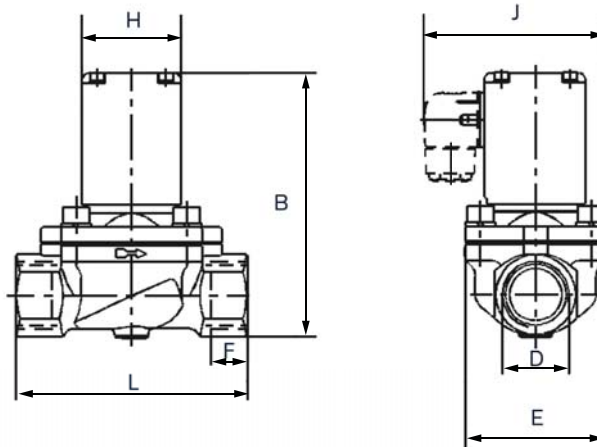

DN	D	B	E	F	H	J	L
20	G 3/4	122	60	16	49	86.5	100
25	G 1	131	70	18	49	91.5	115

## Ordering chart for valves (other versions on request)

All valves with brass body and cable plug

Circuit function	Orifice [mm]	Port connection	Kv-value water [m <sup>3</sup> /h]	Q <sub>Nn</sub> value air [l/min]	Pressure range [bar]	Remarks	Seal material	Coil power [W]	Voltage/Frequency [V/Hz]	Item no.
A	20.0	G 3/4	5.0	5400	0 - 0.15	-	NBR	16	230/50	079 637
						noise reduced		9	230/UC	124 302
	25.0	G 1	10.0	10800	0 - 0.15	-	NBR	16	230/50	077 577
						noise reduced		9	230/UC	124 901

- All electric versions (UC) with integrated rectifier