



2/2-Way Motor Valve

- Seat valve with stepper motor - actuator isolated from flow path
- Low power consumption
- Fast response
- Orifice sizes 2 to 6 mm
- Port connection 1/4" and 3/8"

Type 3270 can be combined with ...



Type 8611

Compact PI Controller

Type 3270 is a direct-acting and general purpose motor valve for shut-off, used as regulating unit in control loops. A linear stepper motor as actuator drives the valve, which comes in a compact and robust housing. Analogue input signals are processed by the integrated control electronics. Due to an elastomeric seat seal the valve closes tight up to the DN specific nominal pressure (see ordering chart on p. 4). In case of power failure, the actual valve position will be kept. The motor's power consumption in opened or closed position is nearly zero. Only during valve switching does the motor need power. This key feature can reduce the energy consumption of a plant dramatically and thus make it more efficient.

Circuit function

2-way valve, motor driven, remains in position without further electrical power

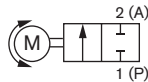

Technical data	
Materials	
Body	Brass or stainless steel
Housing	PC (Polycarbonate), PPS (Polyphenylene sulfide)
Seals	FKM or NBR, others on request
Medium	Neutral gases, liquids
Pressure Range ¹⁾	0 to 6 bar
Closure time	2.5 s (0 to 100% stroke)
Fluid temperature	0 to +70 °C
Ambient temperature	-10 to +60 °C
Viscosity	Max. 600 mm ² /s (cSt)
Power supply	24 V DC ± 10% (max. residual ripple 10%)
Power consumption	Max. 8 W (depending on motor control), < 1 W in holding position
Duty cycle	Up to 100 % (depending on fluid and ambient temperature)
Port connection	G 1/4, G 3/8, NPT 1/4, NPT 3/8
Electrical connection	M12 connector, 8-pin, male
Input signal	Binary signal, PNP, 0-5V (log. 0, valve closed) or 10-30V (log. 1, valve open)
Output signal	Load capacity 10-30V, PNP, max. 100mA (Output signal active, if valve is closed)
Protection class - valve	IP 50
Installation	As required, preferably with actuator upright
Status of LED	White: Normal operation and powered, Yellow: Valve opened, Green: Valve closed, Red: Failure
Dimensions	See drawings on page 4
Weight	~0.7 kg

¹⁾ Pressure data [bar]: Overpressure with respect to atmospheric pressure

Duty Cycle Derating Curve

For motor valves it is essential to know the duty cycle during operation. Self-heating of the motor limits the maximum duty cycle. High ambient temperatures amplify the risk of damage due to overheating. The diagram below shows the suggested duty cycles dependent on the ambient temperature. Running the motor valve in the power saving mode (lower actuator force) allows higher duty cycles. The motor is optimized for the valve function regarding dimensions, power consumption and costs.

Note: Operating the valve beyond the suggested duty cycles leads to a drastically reduced lifetime of the valve.

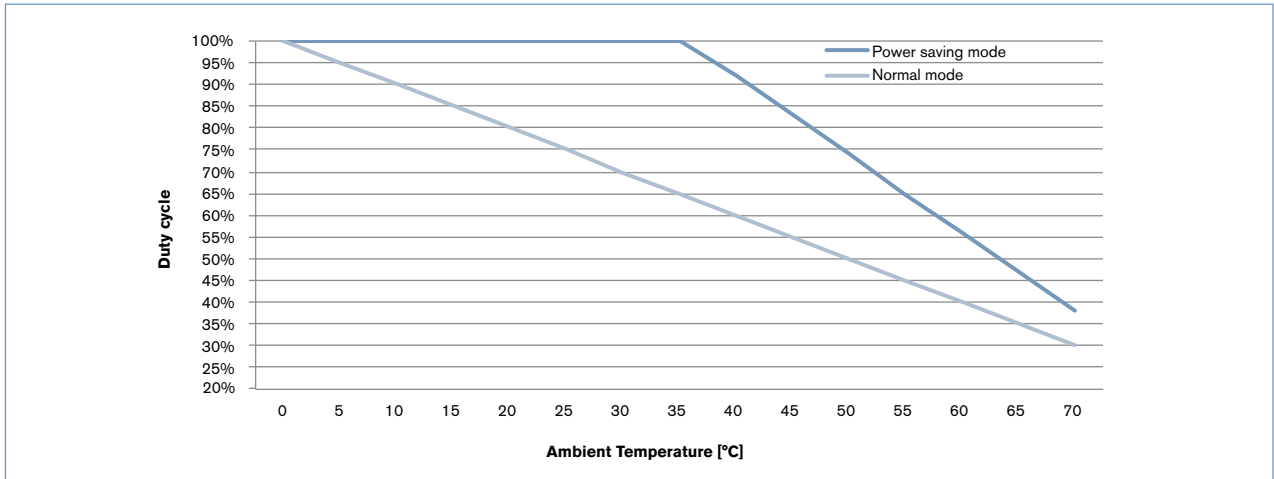

Materials

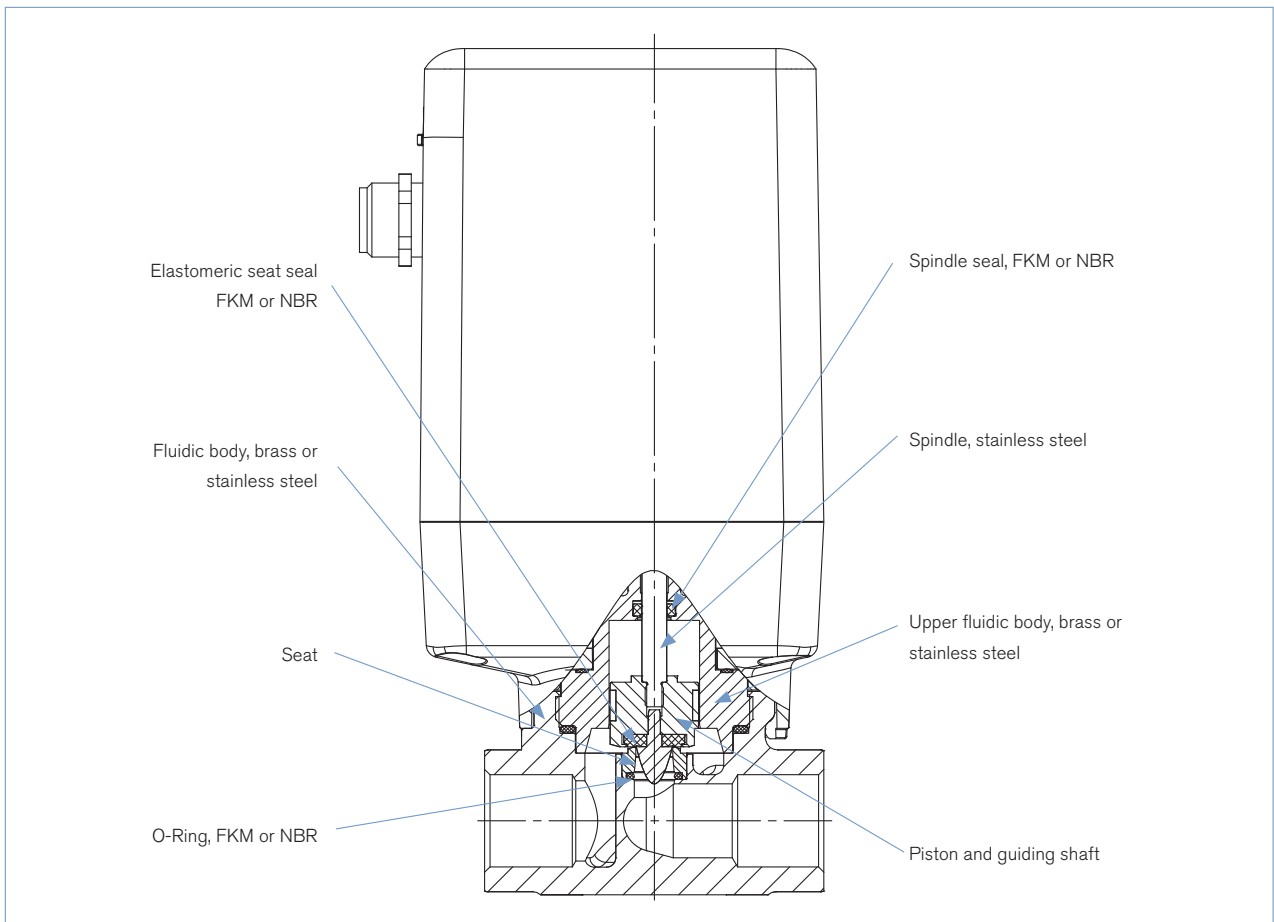

Dimensions [mm]

Standard version

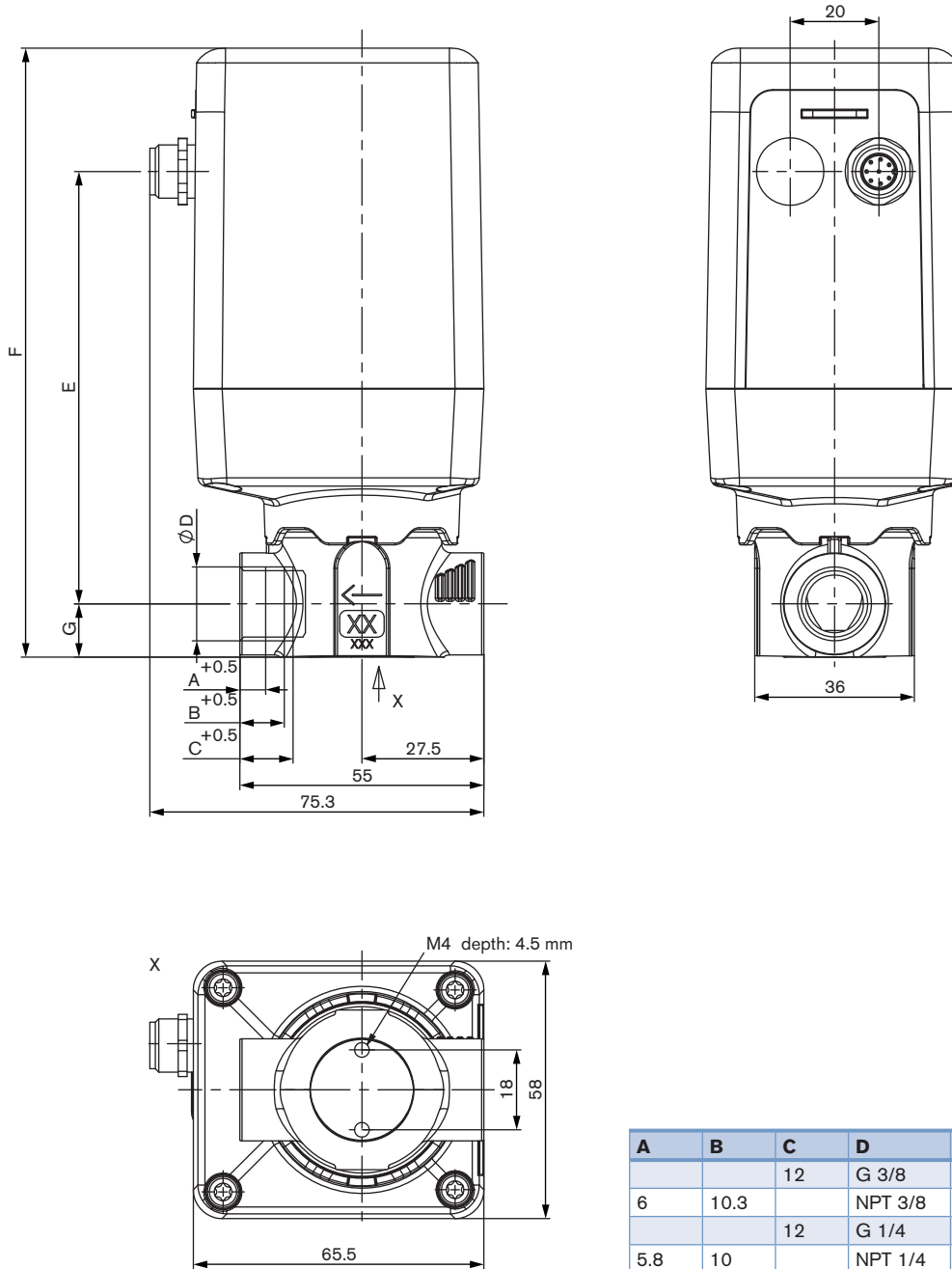

Pin Assignment

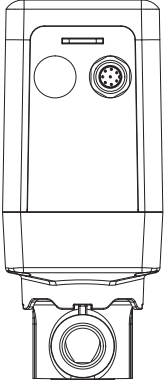
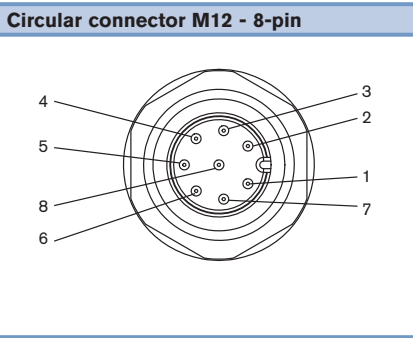
	Circular connector M12 - 8-pin																		
		<table border="1"> <thead> <tr> <th>Pin</th> <th>Assignment</th> </tr> </thead> <tbody> <tr> <td>1</td> <td>24V DC</td> </tr> <tr> <td>2</td> <td>GND</td> </tr> <tr> <td>3</td> <td>Not connected</td> </tr> <tr> <td>4</td> <td>Not connected</td> </tr> <tr> <td>5</td> <td>Not connected</td> </tr> <tr> <td>6</td> <td>Valve actuating +</td> </tr> <tr> <td>7</td> <td>Binary output</td> </tr> <tr> <td>8</td> <td>Valve actuating GND</td> </tr> </tbody> </table>	Pin	Assignment	1	24V DC	2	GND	3	Not connected	4	Not connected	5	Not connected	6	Valve actuating +	7	Binary output	8
Pin	Assignment																		
1	24V DC																		
2	GND																		
3	Not connected																		
4	Not connected																		
5	Not connected																		
6	Valve actuating +																		
7	Binary output																		
8	Valve actuating GND																		

Ordering Chart

Valve function	Orifice [mm]	Port Connection	Seal material	k_{vs} value water [m ³ /h] ²⁾	Nominal pressure [barg] ³⁾	Item no. brass	Item no. stainless steel
Shut-off valve, without safety position in case of power failure	2	G 1/4	FKM	0.15	6	268 576	268 584
			NBR	0.15	6	268 580	268 588
		NPT 1/4	FKM	0.15	6	268 592	268 600
			NBR	0.15	6	268 596	268 604
	3	G 1/4	FKM	0.3	6	268 577	268 585
			NBR	0.3	6	268 581	268 589
		NPT 1/4	FKM	0.3	6	268 593	268 601
			NBR	0.3	6	268 597	268 605
	4	G 3/8	FKM	0.5	6	268 578	268 586
			NBR	0.5	6	268 582	268 590
		NPT 3/8	FKM	0.5	6	268 594	268 602
			NBR	0.5	6	268 598	268 606
6	G 3/8	FKM	0.9	6	268 579	268 587	
		NBR	0.9	6	268 583	268 591	
	NPT 3/8	FKM	0.9	6	268 595	268 603	
		NBR	0.9	6	268 599	268 607	

²⁾ Measured with water (20°C) and 1 bar pressure drop over valve

³⁾ Fuel gases may differ

Ordering Chart for Accessories

Article	Item No.
M12 connector with 2m cable, 8 pins	919 061
M12 connector with 2m cable, 8 pins (shielded cable)	918 991

In case of special application conditions, please consult for advice.

Subject to alteration.
© Christian Bürkert GmbH & Co. KG

1503/2_EU-en_00895276