



2/2-way Angle-Seat Valve with stainless steel design for medium up to +185 °C, DN 15-50

- High flow rates
- High cycle life
- Flow optimised body in stainless steel
- Deliverable with flow direction below or above seat
- Clean design for optimal use in hygienic environment
- Suitable for steam up to 10 bar(g)

Type 2100 clamp can be combined with...



Type 8691

Control Head



Type 8695

Control Head



Type 8690

Pneumatic Control Unit



Type 8697

Pneumatic Control Unit



Type 8619

MultiCELL Transmitter/Controller



Type 8222

Conductivity transmitter

In line with Bürkert's philosophy for modular valves and sensors the construction of the 2100 angle-seat valve fulfils tough criteria for process environments. Unrivalled cycle life and sealing integrity is guaranteed by the proven self adjusting spindle packing with V-seals.

The design enables the easy integration of automation modules whether they are electrical/optical position feedback, pneumatic control units, an integrated fieldbus interface.

The fully integrated system has a compact and smooth design, integrated pneumatic lines, IP65/67 protection class and superior chemical resistance.

Optionally, an explosion-proof version is also available.

Technical data	
Orifice	DN15 to DN50
Port connections	ISO 2852, ASME BPE Clamp acc. to Weld and threaded see separate data sheet
Body material	Stainless steel 316L
Nominal pressure	PN25 (Body)
Actuator material	PPS Stainless steel 1.4561 (316Ti)
Sealing material	PTFE
Medium	Water, alcohol, oils, fuels, hydraulic fluids, salt solution, alkali solutions, organic solvents, steam, optional fuel gas (EC Gas Appliances Directive 2009/142/EG)
Viscosity	max. 600 mm ² /s
Spindle packing	PTFE V-rings with spring compensation
Medium temperature	-10 to +185°C
Ambient temperature	0 to +55 °C (integrated control head) 0 to +60 °C (push-in air ports) 0 to +100 °C (threaded air ports)
Control medium	Neutral gases, air
Max. pilot pressure	max. 10 bar; actuator size 130 mm, 7 bar
Pilot air ports	Push-in connector for external ø 6 mm or 1/4" tube, thread G1/8 (on request)
Installation	As required, preferably with actuator in upright position
Surface Finish, standard	in internal connection area Ra ≤ 0.6 µm electropolished (external cast surface)

Content

 Valve specifications Type 2100	 System spec. On/Off ELEMENT Type 8801-YE	Request for quotation Type 8801-YE
Technical data & ordering info. p. 1-6	Technical data & ordering info. p. 7-11	p.12

Technical data angle seat valve Type 2100 flow direction below the seat (for gases and liquids)

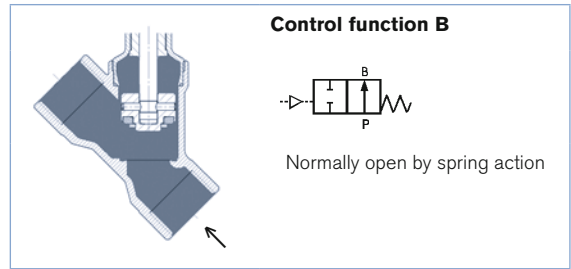
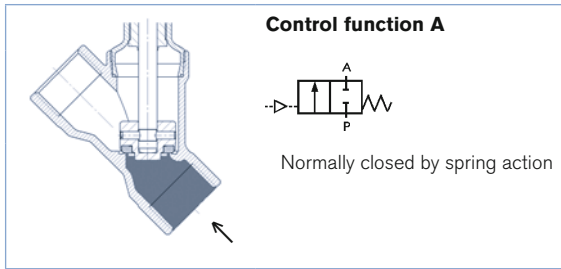

Orifice [mm]	Actuator size [mm]	Kv value water (m³/h)	Minimum pilot pressure CFA [bar]	Operating pressure up to +185°C	
				CFA [bar]	CFB [bar]
15	50	5	5.2	25	16
	70	5	5.0	25	16
20	50	10	5.2	16	16
	70	11	5.0	20	16
25	50	15	5.2	9	14.5
	70	18	5.0	16	16
32	70	27	5.0	8.5	16
	90	28	5.0	16	16
40	70	38	5.0	6	16
	90	40	5.0	16	16
50	70	52	–	–	16
	90	55	5.0	10	16
	130	62	5.0	16	16

Flow rate: Kv value water [m³/h]: Measured at +20°C, 1 bar pressure at valve inlet and free outlet.
Pressure valves [bar]: Overpressure to the atmospheric pressure

Pressure charts with control function B and flow direction below the seat

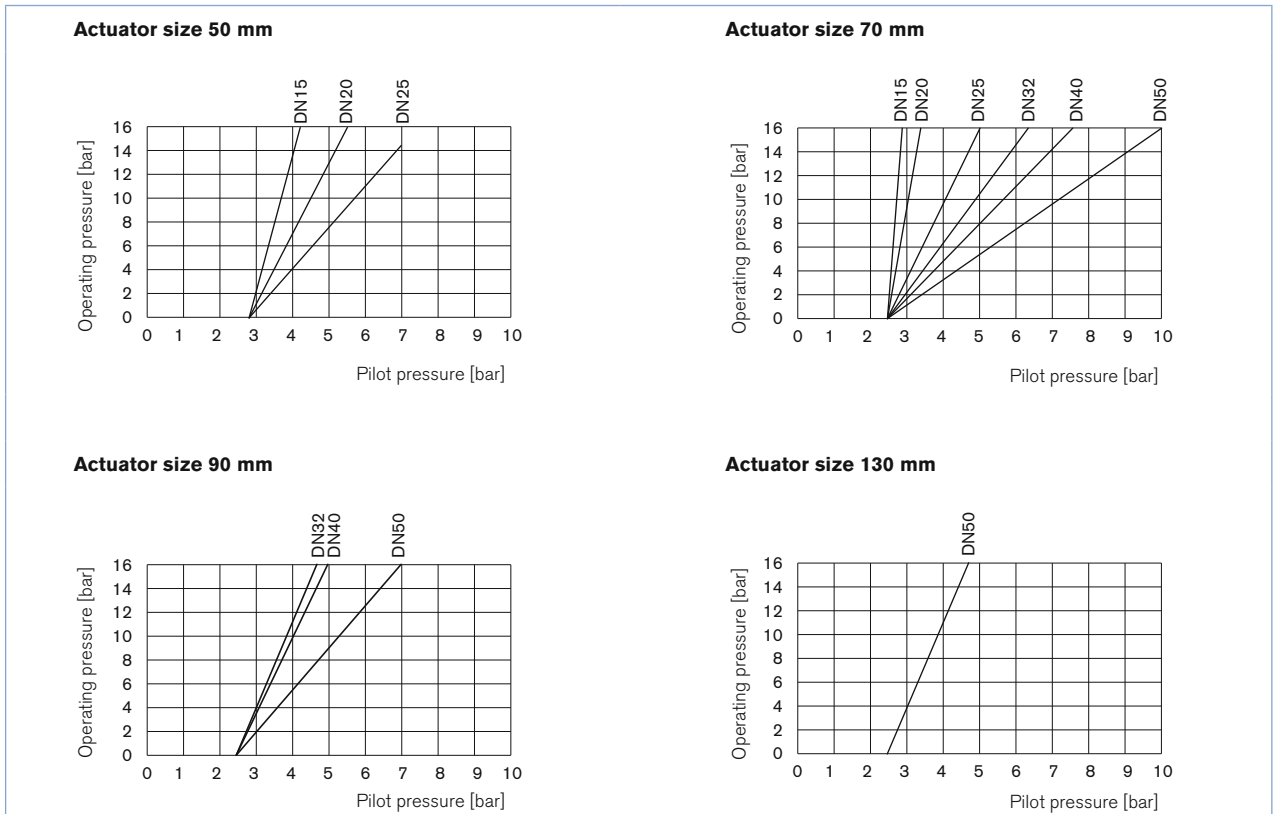

Ordering chart Type 2100, flow direction below the seat (for gases and liquids)

Clamp acc. to ISO 2852, flow direction below the seat

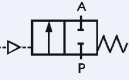
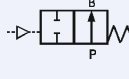
Control function	Orifice (mm)	Actuator size \varnothing [mm]	Port connection clamp external \varnothing (mm)	Minimum pilot pressure [bar]	Operating pressure up to +185°C [bar]	Item no.	
A 2/2-way valve, NC 	15	50	34.0	5.2	25	187 097	
		70	34.0	5.0	25	188 783	
	20	50	50.5	5.2	16	209 437	
		70	50.5	5.0	20	188 784	
	25	50	50.0	5.2	9	227 613	
		70	50.5	5.0	16	188 785	
	32	70	50.5	5.0	8.5	188 786	
		90	50.5	5.0	16	188 787	
	40	70	64.0	5.0	6	188 788	
		90	64.0	5.0	16	188 789	
	50	90	77.5	5.0	10	188 790	
		130	77.5	5.0	16	188 791	
	B 2/2-way valve, NO 	15	50	34.0	see chart on p. 2	16	187 101
			70	34.0		16	188 800
20		50	50.5	16		187 102	
		70	50.5	16		188 801	
25		70	50.5	16		188 802	
		32	70	50.5		16	188 803
40		70	64.0	16		188 804	
		50	70	77.5		16	188 805

Clamp acc. to ASME BPE, flow direction below the seat

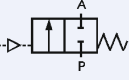
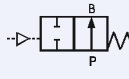
Control function	Orifice (mm)	Actuator size \varnothing [mm]	Port connection clamp external \varnothing (mm)	Minimum pilot pressure [bar]	Operating pressure up to +185°C [bar]	Item no.
A 2/2-way valve, NC 	15	50	25.0	5.2	25	187 103
		70	25.0	5.0	25	188 806
	20	50	25.5	5.2	16	227 614
		70	25.5	5.0	20	188 807
	25	50	50.5	5.2	9	227 615
		70	50.5	5.0	16	188 808
	40	70	50.5	5.0	6	188 809
		90	50.5	5.0	16	188 810
	50	90	64.0	5.0	10	188 811
		130	64.0	5.0	16	188 812
B 2/2-way valve, NO 	15	50	25.0	see chart on p. 2	16	187 107
		70	25.0		16	188 820
	20	50	25.0		16	187 108
		70	50.5		16	188 821
	25	70	50.5		16	188 822
		40	70		50.5	16
	50	70	64.0		16	188 824

i Further versions on request

Control function
 I (double-acting)

Technical data angle seat valve Type 2100 flow direction above the seat (for gases and steam)

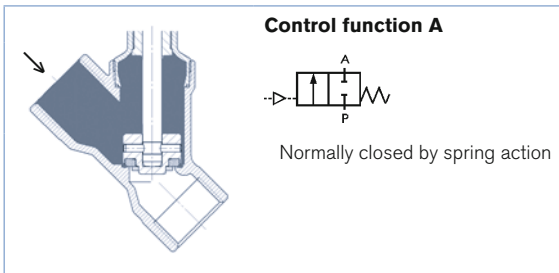

Attention!

Valves with flow above the seat are only conditionally usable for liquid medium. There is a danger of waterhammer!

Orifice [mm]	Actuator size [mm]	Kv value water (m ³ /h)	Operating pressure up to +185°C CFA [bar]
15	50	5	16
	70	5.1	16
20	50	10	16
	70	12	16
25	50	15	16
	70	19	16
32	70	28	16
40	70	38	16
	90	40	16
50	70	50	12
	90	55	16

Flow rate: Kv value water [m³/h]: Measured at +20°C, 1 bar pressure at valve inlet and free outlet.

Pressure valves [bar]: Overpressure to the atmospheric pressure

Pressure charts with control function A and flow direction above the seat

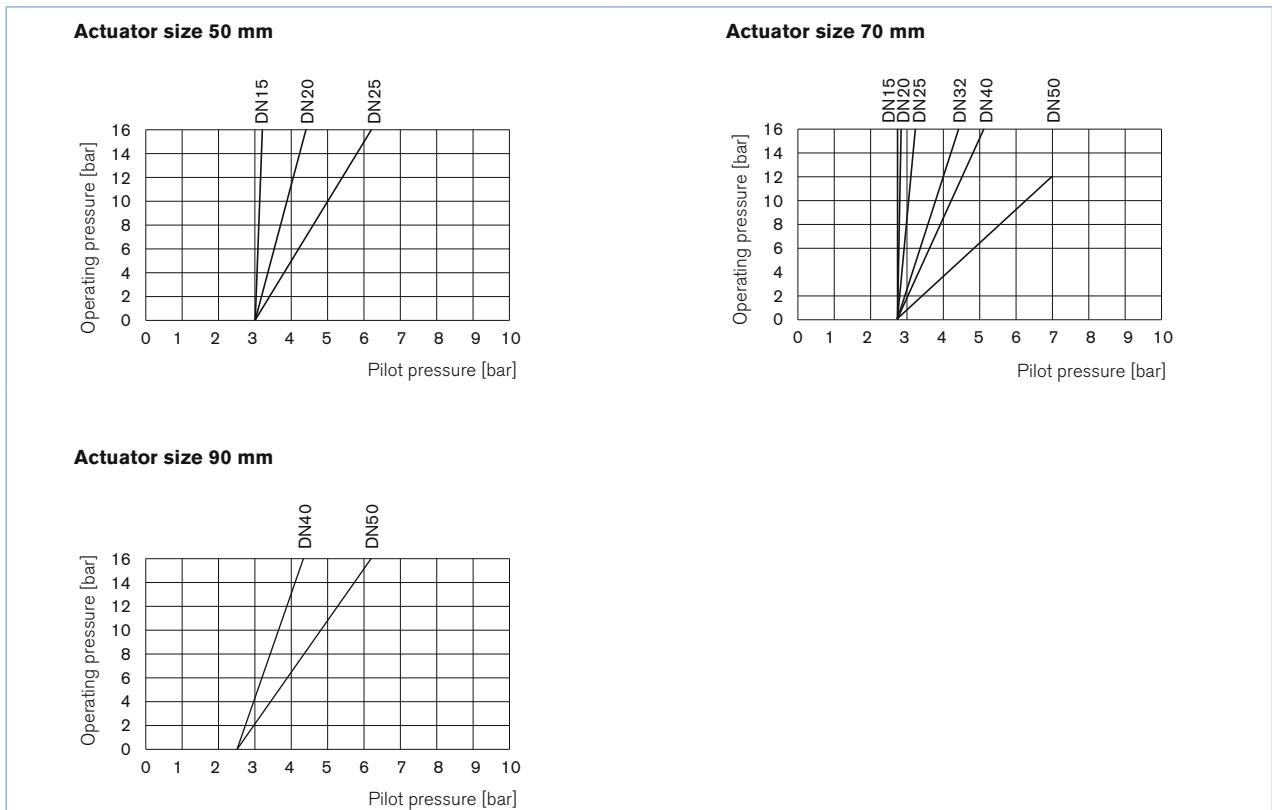

Ordering chart Type 2100 flow direction above the seat (for gases and steam)

Clamp acc. to ISO 2852, flow direction above the seat

Control function	Orifice (mm)	Actuator size \varnothing [mm]	Port connection clamp external \varnothing (mm)	Minimum pilot pressure [bar]	Operating pressure up to +185°C [bar]	Item no.
A 2/2-way valve. NC 	15	50	34.0	see chart on p. 4	16	187 098
	20	50	50.5		16	187 099
	25	50	50.5		16	187 100
	32	70	50.5		16	188 795
	40	70	64.0		16	188 796
	50	70	77.5		12	188 798

Clamp acc. to ASME BPE, flow direction above the seat

Control function	Orifice (mm)	Actuator size \varnothing [mm]	Port connection clamp external \varnothing (mm)	Minimum pilot pressure [bar]	Operating pressure up to +185°C [bar]	Item no.
A 2/2-way valve. NC 	15	50	25.0	see chart on p. 4	16	187 104
	20	50	25.0		16	187 105
	25	50	50.5		16	187 106
	40	70	50.5		16	188 816
	50	70	64.0		12	188 818

Materials angle seat valve Type 2100

A	Ground terminal	Stainless steel 1.4301/1.4305 <i>Only for the ATEX version</i>
1	Optical position indicator	Transparent cap polysulfone PSU
2	Pilot air ports	Push-in connector PP (standard) <i>On request:</i> Thread G1/8" stainless steel 1.4305
3	Actuator	PPS
4	Cover	Stainless steel 1.4561 (316Ti)
5	Piston seal	FKM
6	Spring	Stainless steel 1.4310
7	Pipe	Stainless steel 1.4401 (316)/1.4404 (316L)
8	Spindle packing	PTFE
9	Spindle	Stainless steel 1.4401 (316)/1.4404 (316L)
10	Spindle guide	PEEK
11	Swivel plate	Stainless steel 1.4401 (316)/1.4404 (316L)
12	Seals	PTFE
13	Valve body	Stainless steel 316L

Lubricants for spindle packing and actuator are classified according NSF H1

Dimensions angle seat valve Type 2100 [mm]

Clamp body

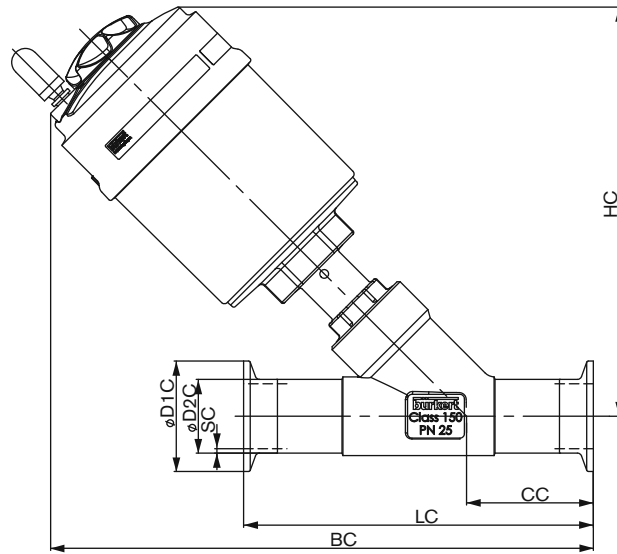

ISO 2852, DIN 32676

All bodies		Clamp body acc. to ISO 2852							DIN 32676				
Orifice [mm]	Actuator size [mm]	HC	BC	CC	LC	øD1C	øD2C	SC	CC	LC	øD1C	øD2C	SC
15	50	163	215	49	130	34	21.3	1.6	49.5	130	34	19	1.5
	70	178	231										
20	50	171	230	56.5	150	50.5	26.9	1.6	57	150	34	23	1.5
	70	186	246										
25	50	172	233	58	160	50.5	33.7	2	58.5	160	50.5	29	1.5
	70	188	249										
32	70	197	258	57.5	180	50.5	42.4	2	58	180	50.5	35	1.5
	90	242	300										
40	70	201	273	69	200	64	48.3	2	69.5	200	50.5	41	1.5
	90	245	316										
	130	296	365										
50	70	219	300	77.5	230	77.5	60.3	2.6	78	230	64	53	1.5
	90	261	340										
	130	312	389										

BS 4825, ASME BPE

All bodies		Clamp body acc. to BS 4825							ASME BPE				
Orifice [mm]	Actuator size [mm]	HC	BC	CC	LC	øD1C	øD2C	SC	CC	LC	øD1C	øD2C	SC
15	50	163	215	49	130	25.2	12.7	1.2	49	130	25	12.7	1.65
	70	178	231										
20	50	171	230	56.5	150	25.2	19.05	1.2	56.5	150	25	19.05	1.65
	70	186	246										
25	50	172	233	58	160	50.5	25.4	1.65	-	-	-	-	-
	70	188	249										
40	70	201	273	69	200	50.5	38.1	1.65	-	-	-	-	-
	90	245	316										
	130	296	365										
50	70	219	300	77.5	230	64	50.8	1.65	-	-	-	-	-
	90	261	340										
	130	312	389										

**2100 clamp
System On/Off
ELEMENT 8801-YE**

Ordering information for valve system On/Off ELEMENT Type 8801-YE

A **valve system On/Off ELEMENT Type 8801-YE** consists of a **angle seat valve Type 2100** and a valve actuation system control head **Type 8691/8695** or a pneumatic control unit **Type 8690/8697** (see separate datasheets).

For the configuration of further valve systems please use the "Request for quotation" on p. 13-14.

[go to page](#)

You order two components and receive a complete assembled and certified valve.

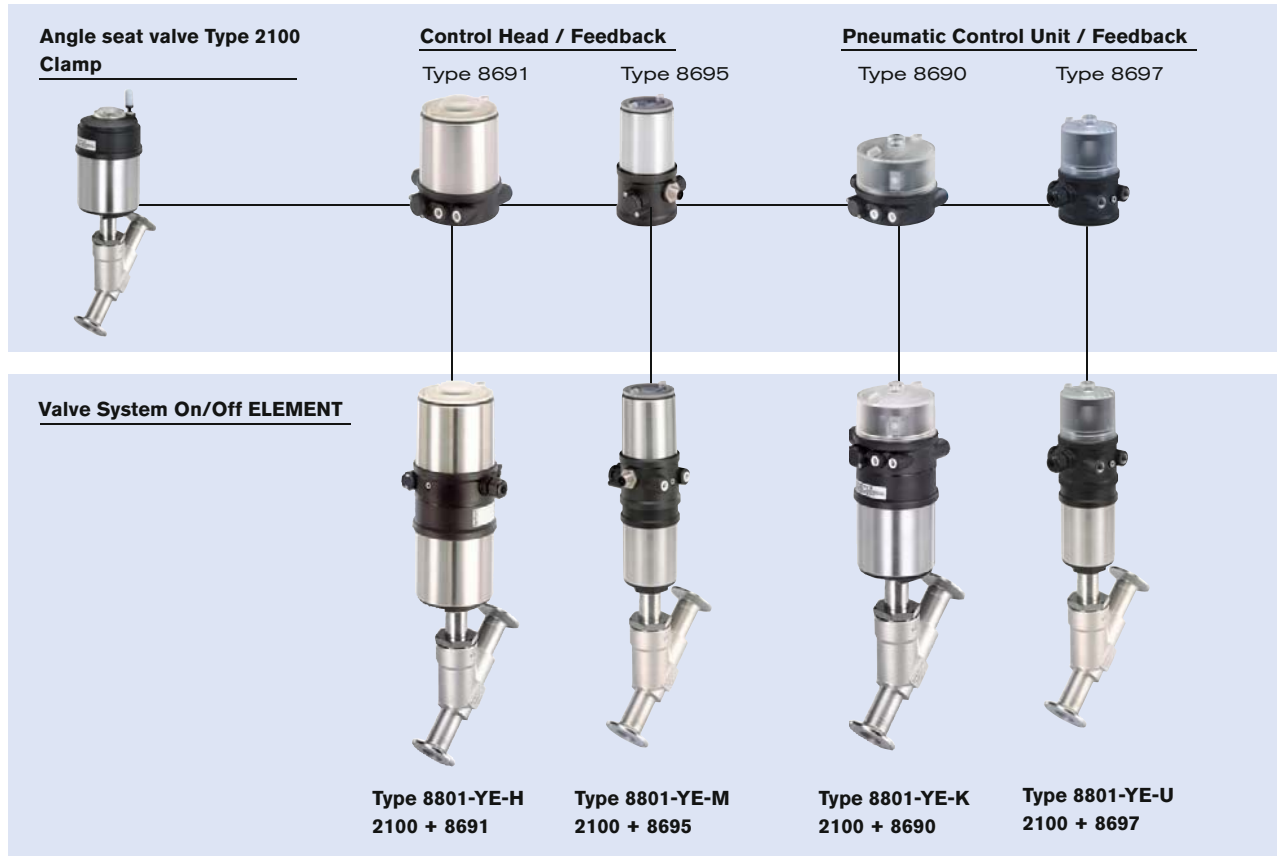

A detailed description of the control heads and pneumatic control units is on the next page... →

Ordering information for valve system On/Off ELEMENT Type 8801-YE, *continued*

Control Head / Feedback



More info.



More info.

Type 8691

Actuator size 70/90/130

Type 8695

Actuator size 50

The Control Head Type 8691/ 8695 is optimised for integrated mounting on the 21XX process valve series. The registration of the valve end position is done through a contactless analog position sensor, which automatically recognises and saves the valve end position through the Teach function when starting up. The integrated pilot valve controls single or double-acting actuators. The status of the valve is shown through high power coloured LEDs.

Features

- High power coloured Status-LEDs
- Contactless inductive position sensor
- Pilot valve with manual override
- Teach function for automatic registration of valve positions
- Hygienic stainless steel design
- Easy to clean chemically resistant housing featuring IP65 / IP67, 4X Rating
- AS-Interface or DeviceNet Fieldbus communication

Benefits

- Easy and safe Start-up through Teach function
- Easy process monitoring and error detection through clearly visible high-power coloured LEDs
- High plant availability due to prolonged actuator life boosted by spring chamber ventilation
- Minimised space requirement in the plant piping for more flexibility in plant design

Pneumatic Control Unit / Feedback



More info.



More info.

Type 8690

Actuator size 70/90/130

Type 8697

Actuator size 50

The pneumatic control unit Type 8697/8690 is optimised for integrated mounting on the 21XX process valve series. Mechanical or inductive limit switches register the position of the valve. The integrated pilot valve controls single or double-acting (8690) actuators.

Features

- Visual position indicator
- Mechanical or inductive limit switches for end position registering
- Pilot valve with manual override
- Compact design
- Easy to clean chemically resistant housing featuring IP65 / IP67, 4X Rating
- Optional intrinsically safe version acc. to ATEX

Benefits

- Easy and safe Start-up through Teach function (Type 8697)
- High level of signal reliability thanks to self adjusting limit switches
- Minimised space requirement in the plant piping for more flexibility in plant design

Click on the orange box "More info"... you will come to our website for the resp. product where you can download the data sheet.

Dimensions for valve system On/Off ELEMENT Type 8801-YE [mm]

Dimensions valve system On/Off ELEMENT Type 8801-YE-K (with pneumatic control unit Type 8690)

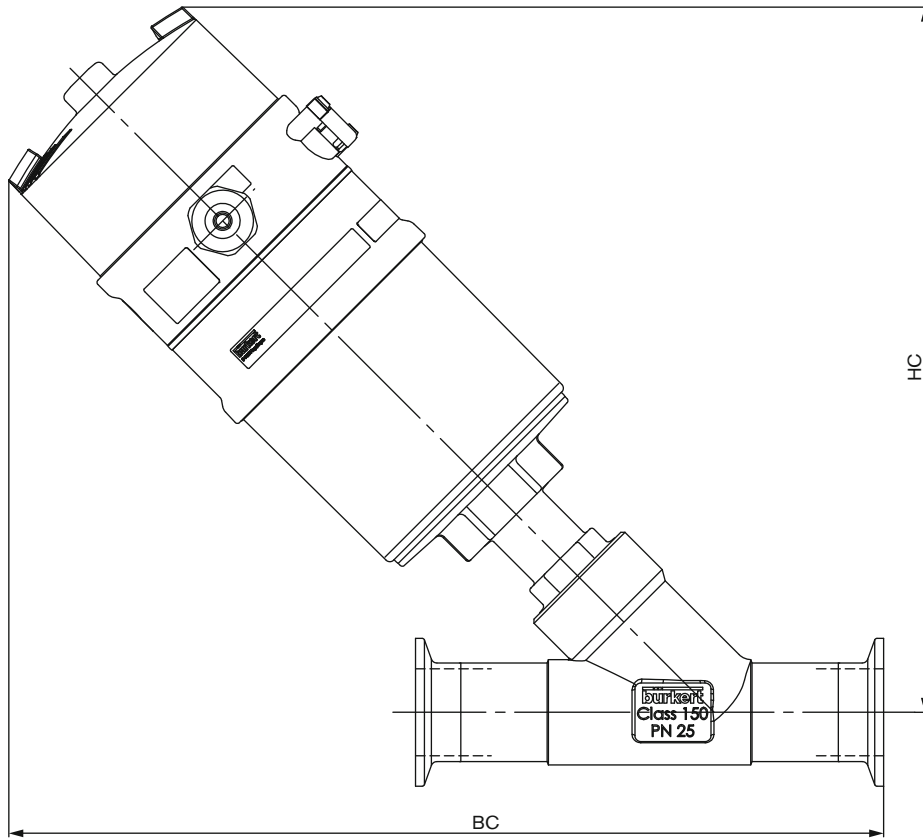

Clamp body acc. to ISO 2852, DIN 32676, BS 4825, ASME BPE

Orifice [mm]	Actuator size [mm]	HC	BC
15	70	232	285
20	70	240	300
25	70	242	303
32	70	251	312
	90	294	352
40	70	255	327
	90	297	368
	130	334	403
50	70	273	354
	90	313	392
	130	350	427

Further dimensions see p. 6

Dimensions for valve system On/Off ELEMENT Type 8801-YE [mm]

Dimensions valve system On/Off ELEMENT Type 8801-YE-K (with pneumatic control unit Type 8697)

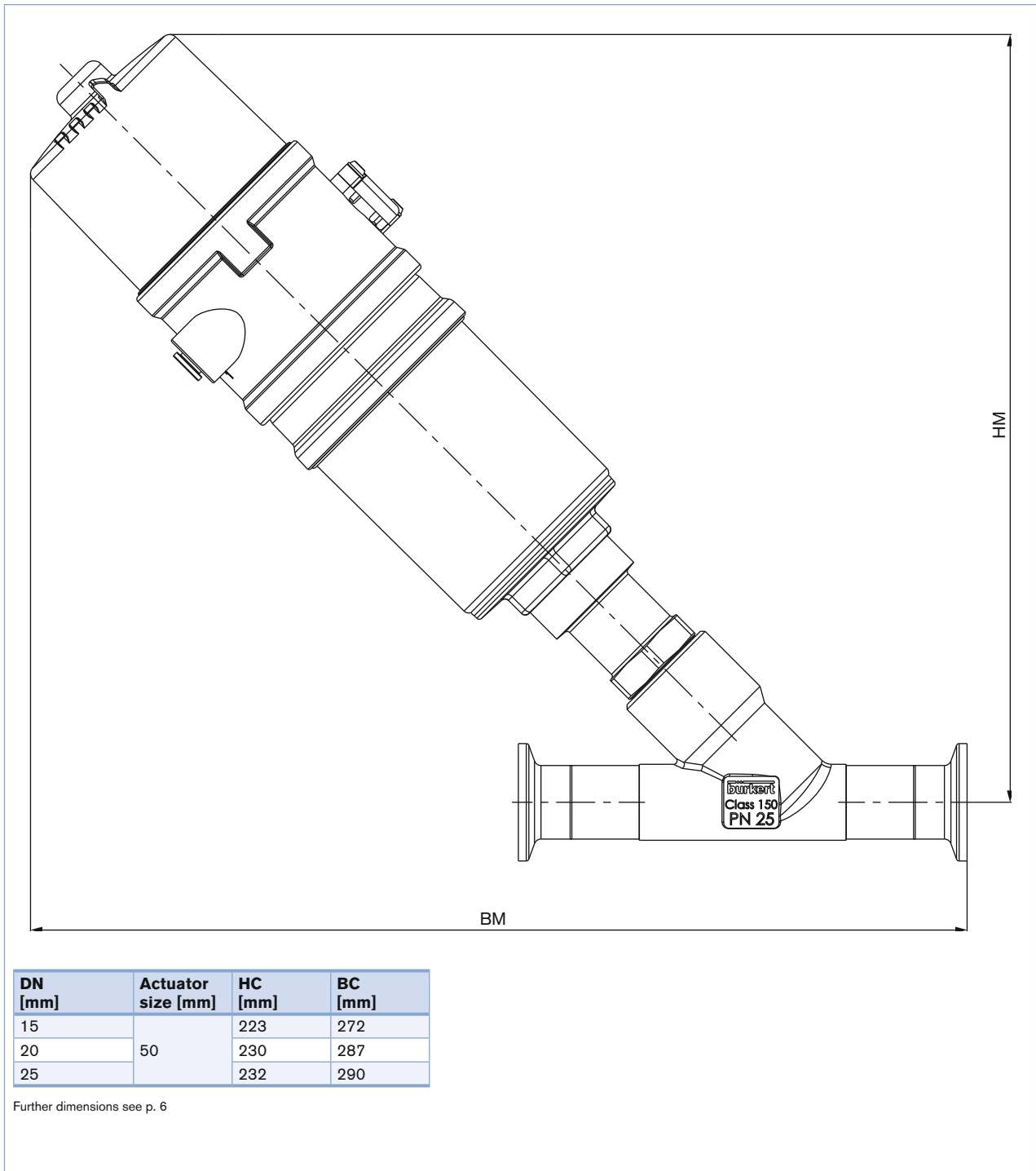

Dimensions for valve system On/Off ELEMENT Type 8801-YE [mm], *continued*

Dimensions valve system On/Off ELEMENT Type 8801-YE-H (*with pneumatic control unit Type 8691*)

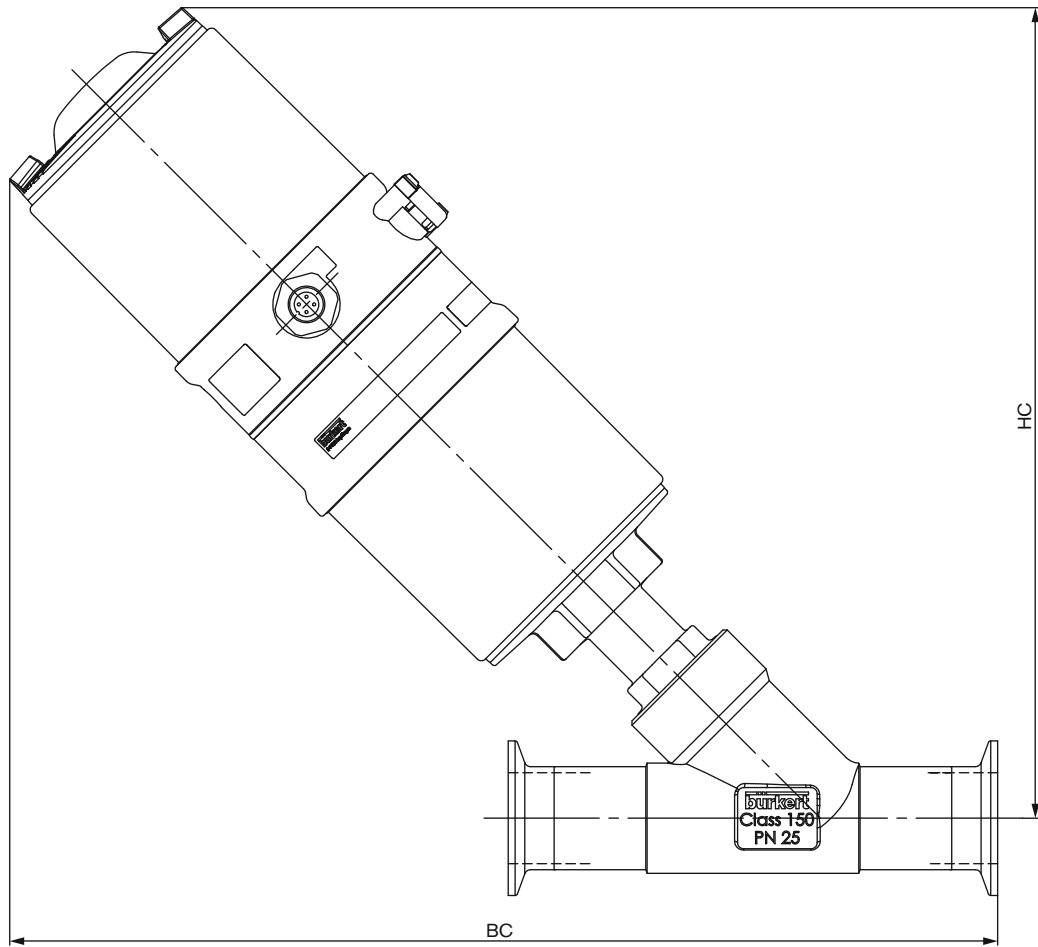

Clamp body acc. to ISO 2852, DIN 32676, BS 4825, ASME BPE

Orifice [mm]	Actuator size [mm]	HC	BC
15	70	256	309
20	70	264	324
25	70	266	327
32	70	275	336
	90	318	376
40	70	279	351
	90	321	392
	130	358	427
50	70	297	378
	90	337	416
	130	374	451

Further dimensions see p. 6

Dimensions for valve system On/Off ELEMENT Type 8801-YE [mm], *continued*

Dimensions valve system On/Off ELEMENT Type 8801-YE-M (with pneumatic control unit Type 8695)

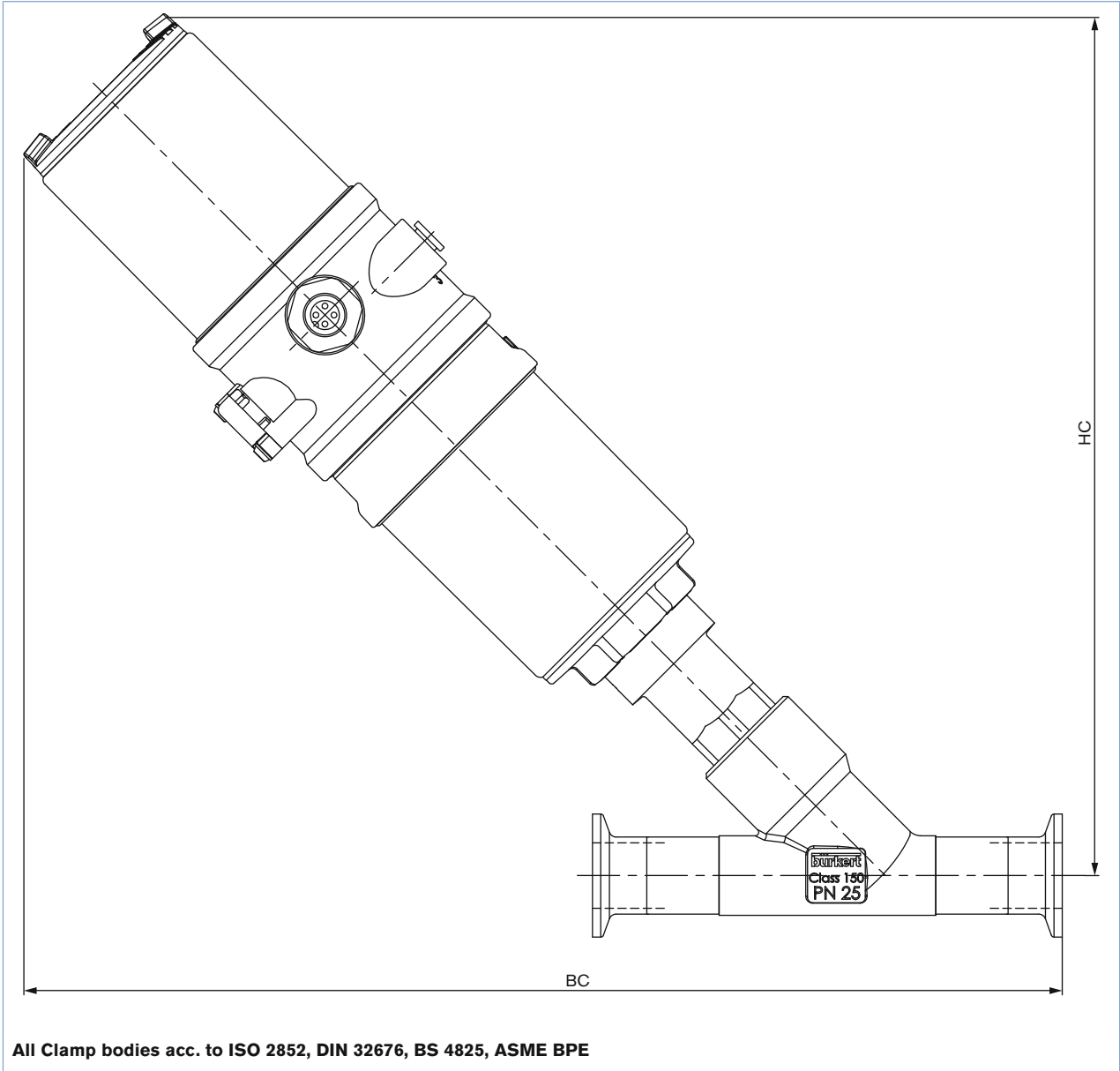

All Clamp bodies acc. to ISO 2852, DIN 32676, BS 4825, ASME BPE

Orifice [mm]	Actuator size [mm]	HC	BC
15	50	239	291
20	50	247	306
30	50	248	309

Further dimensions see p. 6

**2100 clamp
System On/Off
ELEMENT 8801-YE**



Note
You can fill out the fields directly in the PDF file before printing out the form.

Valve system On/Off ELEMENT Type 8801-YE – request for quotation

▶ Please fill out and send to your nearest Bürkert facility* with your inquiry or order

Company	Contact person
Customer no.	Department
Address	Tel./Fax
Postcode/town	E-Mail

= mandatory fields to fill out Quantity Required delivery date

Operating data

Pipe line DN PN

Pipe material

Process medium

Type of media Liquid Steam Gas

Valve features

Seal material PTFE NBR Other

Nominal pressure PN

Orifice DN

Type of connection Threaded Welded Clamp

Standard connection ISO DIN Other

Body material selection with welded connection acc. to EN ISO 1127/ISO 4200 and DIN 11850
 Stainless steel 316L

Control function NC ¹⁾ NO ¹⁾ Double-acting

Pilot pressure min. max.

Atex II 2GD Mechanical

Please specify item no. (if known):









¹⁾NC: normally closed by spring action; NO: normally open by spring action

Continued on next page →

Valve system On/Off ELEMENT Type 8801-YE – request for quotation, *continued*

Automation unit features

Click on the orange box "More info"... you will come to our website for the resp. product where you can download the data sheet.

Control Head / Feedback		Pneumatic Control Unit / Feedback	
<input type="checkbox"/> Type 8691  For actuator size 70/90/130 	<input type="checkbox"/> Type 8695  For actuator size 50 	<input type="checkbox"/> Type 8690  For actuator size 70/90/130 	<input type="checkbox"/> Type 8697  For actuator size 50 
<ul style="list-style-type: none"> Inductive position sensor with automatic Teach function Coloured high power LEDs With/without pilot valve for single or double-acting actuators Fieldbus communication Hygienic stainless steel design 		<ul style="list-style-type: none"> visual status indicator Micro- or proximity switches for end position feedback With/ without pilot valve for single or double-acting actuators Optional intrinsically safe version acc. to ATEX / IECEx 	
Pneumatic function <input type="checkbox"/> Single-acting <input type="checkbox"/> Double-acting <input type="checkbox"/> Without pilot valve	Electrical connection <input type="checkbox"/> Cable gland <input type="checkbox"/> M12 connector	Pneumatic function <input type="checkbox"/> Single-acting <input type="checkbox"/> Double-acting (only with 8690) <input type="checkbox"/> Without pilot valve	Number of Position feedback switches <input type="checkbox"/> 1x <input type="checkbox"/> 2x
Communication <input type="checkbox"/> AS-Interface <input type="checkbox"/> DeviceNet <input type="checkbox"/> without	Approvals <input type="checkbox"/> ATEX cat. 3GD, IECEx <input type="checkbox"/> without	Position feedback switches <input type="checkbox"/> Micro-switch 24V DC <input type="checkbox"/> Micro-switch 50 – 225 V DC/AC (only 8697) <input type="checkbox"/> Inductive switch 3-wire PNP <input type="checkbox"/> Inductive switch 2-wire NAMUR <input type="checkbox"/> Inductive switch 2-wire 24V DC <input type="checkbox"/> without	Electrical connection <input type="checkbox"/> Cable gland <input type="checkbox"/> M12 connector
		Approvals <input type="checkbox"/> ATEX cat. 3GD, IECEx <input type="checkbox"/> ATEX cat. 2DG, IECEx <input type="checkbox"/> without	

Certifications

- Attestation of compliance with the order EN-ISO 10204 2.1 (Item-No. 440 788)
- Test report EN-ISO 10204 2.2 (Item-No. 803 722)
- Certification of Conformity for Raw Material EN-ISO 10204 3.1 (Included in delivery)
- EN161 (European Gas Device guideline)
- FDA and USP compliance

Comment /sketch

In case of special application conditions, please consult for advice.

Subject to alteration.
© Christian Bürkert GmbH & Co. KG

1508/10_EU-en_00895155