



Type 2103 cast On/Off can be combined with...



Type 8691

Control Head



Type 8695

Control Head



Type 8690

Pneumatic
Control Unit



Type 8697

Pneumatic
Control Unit



Type 8619

MultiCELL
Transmitter/Controller



Type 8110

Level meter

2/2-way Diaphragm Valve with stainless steel design, welded or clamp connection, DN 4-50

- Hermetical separation of fluids from the operating mechanism by diaphragm
- Zero dead volume
- Various surface finishes
- Certified according to 
- Clean design for optimal use in hygienic environment

The externally piloted diaphragm valve consists of a pneumatically operated piston actuator, a diaphragm and a 2-way valve housing made of cast stainless steel. The high-quality actuator with a stainless steel cover is designed for usage in hygienic or aggressive environments.

The flow optimised and zero dead volume valve body makes high flow rates possible and a variety of applications to be realised.

The design enables the easy integration of automation modules whether they are electrical/optical position feedback, pneumatic control units, an integrated fieldbus interface or even an explosion proof feedback.

The fully integrated system has a compact and smooth design, integrated pneumatic lines, IP65/67/NEMA4X protection class and superior chemical resistance.

Technical data	
Orifice	DN 4 to 50
Body material	Cast stainless steel 316L / 1.4435
Actuator material Actuator / Cover	PPS / Stainless steel 1.4561 (316Ti)
Diaphragm materials	EPDM (AB), PTFE/EPDM (EA) EPDM (AD), advanced PTFE/EPDM (EU) and FKM (FF) on request
Media	Neutral gases and liquids, high purity, sterile, aggressive or abrasive fluids
Viscosity	up to viscous
Surface finishes internal mechanical polished internal electro polished (on request)	(average surface finish) Ra ≤ 0.8 µm (external cast surface) Ra ≤ 0.6 µm (external cast surface electro polished)
Medium temperatures EPDM (AB), PTFE/EPDM (EA) EPDM (AD), advanced PTFE/EPDM (EU) FKM (FF)	-10 to +130 °C (steam sterilisation +140 °C for 60 min) -5 to +143 °C (steam sterilisation +150 °C for 60 min) 0 to +130 °C (not recommended for steam)
Ambient temperature	+5 to +60 °C
Control medium	Neutral gases, air
Max. pilot pressure	max. 10 bar, 7 bar with actuator size 130 mm

Content



Valve specifications

Type 2103 cast On/Off

Technical data & ordering info.

p. 1-8



System spec. On/Off ELEMENT

Type 8801-DF

Ordering info. & technical data

p. 9-13

Request for quotation

Type 8801-DF

p. 13

Technical data, *continued*

Port connections	<ul style="list-style-type: none"> ▪ DIN EN ISO 1127 / ISO 4200 / DIN 11866 Series B ▪ DIN 11850 Series 2 / DIN 11866 Series A ▪ DIN 11850 Series 0 ▪ SMS 3008 (on request) ▪ DIN 32676 Series A (DIN Tube) ▪ BS4825/ASME BPE ▪ ISO 2852 / SMS 3017 (on request)
Weld end	
Clamp	
Pilot air ports	Push-in connector for external \varnothing 6 mm or 1/4" tube, thread G1/8 (on request)
Installation	as required, preferably with actuator in upright position

¹⁾ Advanced PTFE/EPDM is recommended for sterilization cycle

Technical data valves

Kv-value

Orifice		Kv value water (m ³ /h)	Actuator size \varnothing [mm]	Permitted pilot pressure [bar]		Max. operating pressure [bar] for seal material	
[mm]	[inch]			min.	max.	EPDM, FKM [bar]	PTFE/EPDM and advanced PTFE/EPDM [bar]
4	-	0.8	50	5	10	10	10
6	-	0.8	50	5	10	10	10
8	1/4"	1.0	50	5	10	10	10
10	3/8"	1.0	50	5	10	10	10
15	1/2"	5.5	70	5	10	10	10
20	3/4"	10.0	70	5	10	10	10
25	1"	14.0	70	5	10	6.5	6
			90	5.5	10	10	8
40	1 1/2"	30.0	130	5.0	7	10	10
50	2"	51.5	130	5.0	7	8	7

Flow rate: Kv value water [m³/h]: Measured at +20°C, 1 bar pressure at valve inlet and free outlet.

Pressure valves [bar]: Overpressure to the atmospheric pressure

Installation for self-draining operation

$\alpha = 15$ up to 35° (Marking must face upwards, 12 o'clock position)
plus 3° to 5° inclination to the pipe axis.
Drain marks permanently marked on both sides of the valve body
show the correct mounting position to optimise drain ability.

Approvals

Suitability for foodstuffs / sterile applications



- The composition of the EPDM (AB), EPDM (AD), PTFE/EPDM (EA) and advanced PTFE (EU) diaphragms corresponds to the Code of Federal Regulations, published by the FDA (Food and Drug Administration, USA).



- The composition of the EPDM (AB), EPDM (AD), PTFE/EPDM (EA) and advanced PTFE (EU) diaphragms is suitable for the application with food and beverage (acc. to EC-Regulation 1935/2004/EC)
- The composition of the EPDM (AB), EPDM (AD), PTFE/EPDM (EA) und advanced PTFE (EU) diaphragms are approved acc. USP Class VI
- Approval according to TA-air (Port size DN4-50)

Materials

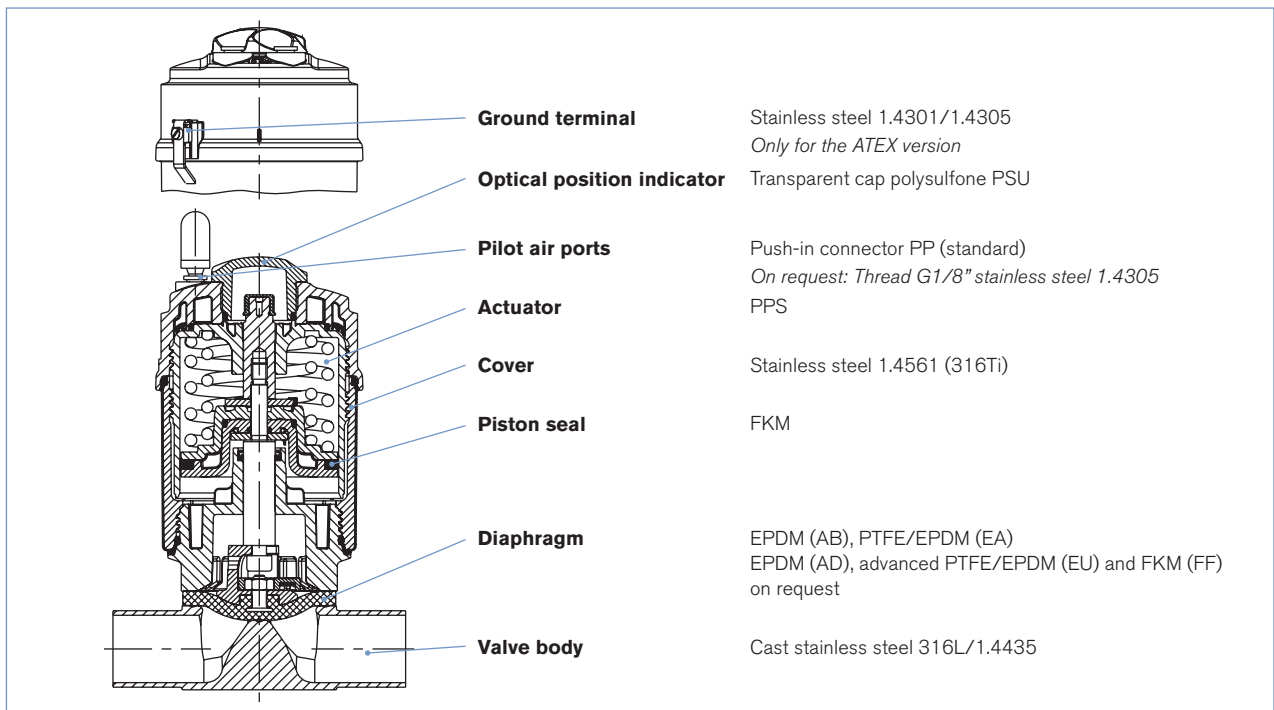

Ordering chart Type 2103 cast diaphragm valve

Welded connection, surface finish mechanical polished, Ra ≤ 0.8 µm, further on request

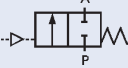
Control function	Orifice		External-Ø [mm]	Kv value water (m³/h)	Actuator size Ø [mm]	Pilot pressure [bar]	Max. operating pressure [bar]	Item no. mechanical polished, Ra ≤ 0.8 µm
	[mm]	[inch]						
A 2/2-way valve, normally closed (NC) 	Acc. to EN ISO 1127/ISO 4200/DIN 11866 Series B							
	Diaphragm material EPDM (AB)							
	8	1/4"	13.5	1.0	50	5-10	10	187 239
	15	1/2"	21.3	5.5	70	5-10	10	175 128
	20	3/4"	26.9	10.0	70	5-10	10	175 129
	25	1"	33.7	14.0	70	5-10	6.5	175 131
					90	5.5-10	10	180 345
	40	1 1/2"	48.3	30.0	130	5-7	10	188 360
	50	2"	60.3	51.5	130	5-7	8	188 367
	Diaphragm material PTFE/EPDM (EA)							
	8	1/4"	13.5	1.0	50	5-10	10	187 240
	15	1/2"	21.3	5.5	70	5-10	10	175 132
	20	3/4"	26.9	10.0	70	5-10	10	175 133
	25	1"	33.7	14.0	70	5-10	6	175 134
					90	5.5-10	8	180 346
	40	1 1/2"	48.3	30.0	130	5-7	10	219 312
	50	2"	60.3	51.5	130	5-7	7	219 313
	Acc. to DIN 11850 Series 2/ DIN 11866 Series A							
	Diaphragm material EPDM (AB)							
	10	3/8"	13	1.0	50	5-10	10	187 243
	15	1/2"	19	5.5	70	5-10	10	176 556
	20	3/4"	23	10.0	70	5-10	10	176 557
	25	1"	29	14.0	70	5-10	6.5	176 558
					90	5.5-10	10	180 349
	40	1 1/2"	41.0	30.0	130	5-7	10	188 372
	50	2"	53.0	51.5	130	5-7	8	188 373
	Diaphragm material PTFE/EPDM (EA)							
	10	3/8"	13	1.0	50	5-10	10	187 244
	15	1/2"	19	5.5	70	5-10	10	176 559
	20	3/4"	23	10.0	70	5-10	10	176 560
25	1"	29	14.0	70	5-10	6	176 561	
				90	5.5-10	8	180 350	
40	1 1/2"	41.0	30.0	130	5-7	10	188 374	
50	2"	53.0	51.5	130	5-7	7	188 375	
Acc. to DIN 11850 Series 0								
Diaphragm material EPDM (AB)								
4	-	6	0.8	50	5-10	10	187 255	
6	-	8	0.8	500	5-10	10	187 256	
Diaphragm material PTFE/EPDM (EA)								
4	-	6	0.8	50	5-10	10	187 257	
6	-	8	0.8	50	5-10	10	187 258	

i Further versions on request

Material

Diaphragms for steam sterilization EPDM (AD), advanced PTFE / EPDM (EU) and FKM (FF)

Port connection

Welded acc. SMS 3008

Control function

B (normally open) and I (double-acting)

Additional

Surface finishes ≤ 0.6 and further

Ordering chart Type 2103 cast diaphragm valve, continued

Clamp connection, surface finish mechanical polished, Ra ≤ 0.8 µm, further on request

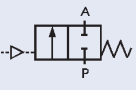
Control function	Orifice		External-Ø [mm]	Kv-value water [m³/h]	Actuator size Ø [mm]	Pilot pressure [bar]	Max. operating pressure [bar]	Item no. mechanical polished, Ra ≤ 0.6 µm
	[mm]	[inch]						
A 2/2-way valve, normally closed (NC) 	Acc. to DIN 32676 Series A							
	Diaphragm material EPDM (AB)							
	15	1/2"	34.0	5.5	70	5-10	10	188 479
	20	3/4"	34.0	10.0	70	5-10	10	188 480
	25	1"	50.5	14.0	70	5-10	6.5	188 481
					90	5.5-10	10	188 482
	40	1 1/2"	50.5	30.0	130	5-7	10	188 483
	50	2"	64.0	51.5	130	5-7	8	188 484
	Diaphragm material PTFE/EPDM (EA)							
	15	1/2"	34.0	5.5	70	5-10	10	188 485
	20	3/4"	34.0	10.0	70	5-10	10	188 486
	25	1"	50.5	14.0	70	5-10	6	188 487
					90	5.5-10	8	188 488
	40	1 1/2"	50.5	30.0	130	5-7	10	188 489
	50	2"	64.0	51.5	130	5-7	7	188 490
	Acc. to ASME BPE							
	Diaphragm material EPDM (AB)							
	8	1/4"	25.0	1.0	50	5-10	10	187 279
	10	3/8"	25.0	1.0	50	5-10	10	187 280
	15	1/2"	25.0	5.5	70	5-10	10	188 527
	25	1"	50.5	14.0	70	5-10	6.5	188 528
					90	5.5-10	10	188 529
	40	1 1/2"	50.5	30.0	130	5-7	10	188 530
	50	2"	64	51.5	130	5-7	8	188 531
	Diaphragm material PTFE/EPDM (EA)							
	8	1/4"	25.0	1.0	50	5-10	10	187 281
	10	3/8"	25.0	1.0	50	5-10	10	187 282
	15	1/2"	25.0	5.5	70	5-10	10	188 532
	25	1"	50.5	14.0	70	5-10	6	188 533
					90	5.5-10	8	188 534
40	1 1/2"	50.5	30.0	130	5-7	10	188 535	
50	2"	64	51.5	130	5-7	7	188 536	

 **Further versions on request**
 **Material**

Diaphragms for steam sterilization EPDM (AD), advanced PTFE/EPDM (EU) and FKM (FF)

 **Port connection**

Clamp acc. to ISO 2852/SMS 3017

 **Control function**

B (normally open) and I (double-acting)

 **Additional**

Surface finishes ≤ 0.6 and further

Dimensions Type 2103 cast diaphragm valve [mm]

Welded connection

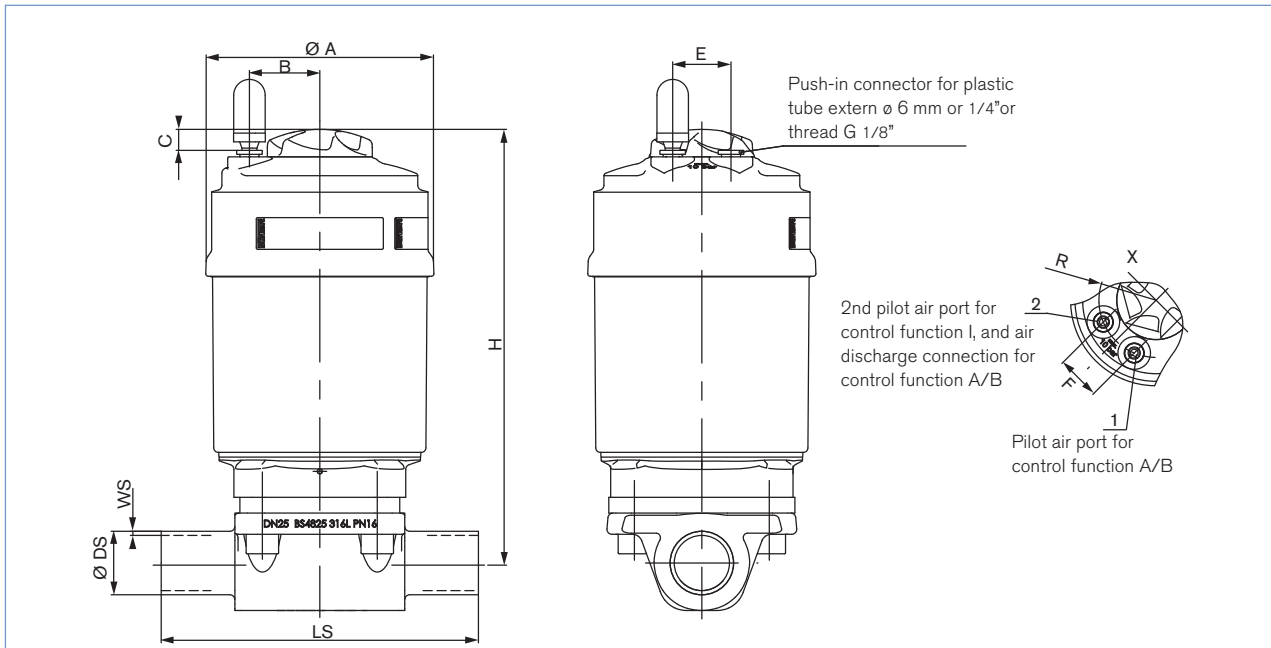

EN ISO 1127/ISO 4200/DIN 11866 Series B and DIN 11850 Series 2/ DIN 11866 Series A

All bodies									EN ISO 1127/ ISO 4200/ DIN 11866 S. B	DIN 11850 S. 2/ DIN 11866 S. A		
Orifice		Actuator size Ø	Ø A	B	C	E	H	LS	Ø DS	WS	Ø DS	WS
[mm]	[inch]	[mm]										
8	1/4"	50	64.5	17.15	6.1	19.8	129	90	13.5	1.6	-	-
10	3/8"	50	64.5	17.15	6.1	19.8	144	110	17.2	1.6	13.0	1.5
15	1/2"	70	91	30.5	8.5	23.3	161	110	21.3	1.6	19.0	1.5
20	3/4"	70	91	30.5	8.5	23.3	171	119	26.9	1.6	23.0	1.5
25	1"	70	91	30.5	8.5	23.3	174	129	33.7	2.0	29.0	1.5
		90	120	30.5	8.5	23.3	207	129	33.7	2.0	29.0	1.5
40	1 1/2"	130	159	30.5	8.5	23.3	288	161	48.3	2.0	41.0	1.5
50	2"	130	159	30.5	8.5	23.3	311	192	60.3	2.0	53.0	1.5

DIN 11850 Series 0

Orifice [mm]	Actuator size Ø [mm]	Ø A	B	C	E	H	LS	Ø DS	WS
4	50	64.5	17.15	6.1	19.8	129	90	6	1.0
6	50	64.5	17.15	6.1	19.8	129	90	8	1.0

On request: SMS 3008

Orifice		Actuator size Ø	Ø A	B	C	E	H	LS	Ø DS	WS
[mm]	[inch]	[mm]								
25	1"	70	91	30.5	8.5	23.3	174	127	25	1.2
		90	120	30.5	8.5	23.3	207	127	25	1.2
40	1 1/2"	130	159	30.5	8.5	23.3	288	161	38	1.2
50	2"	130	159	30.5	8.5	23.3	311	192	51	1.2

Dimensions Type 2103 cast diaphragm valve [mm], *continued*

Clamp connection

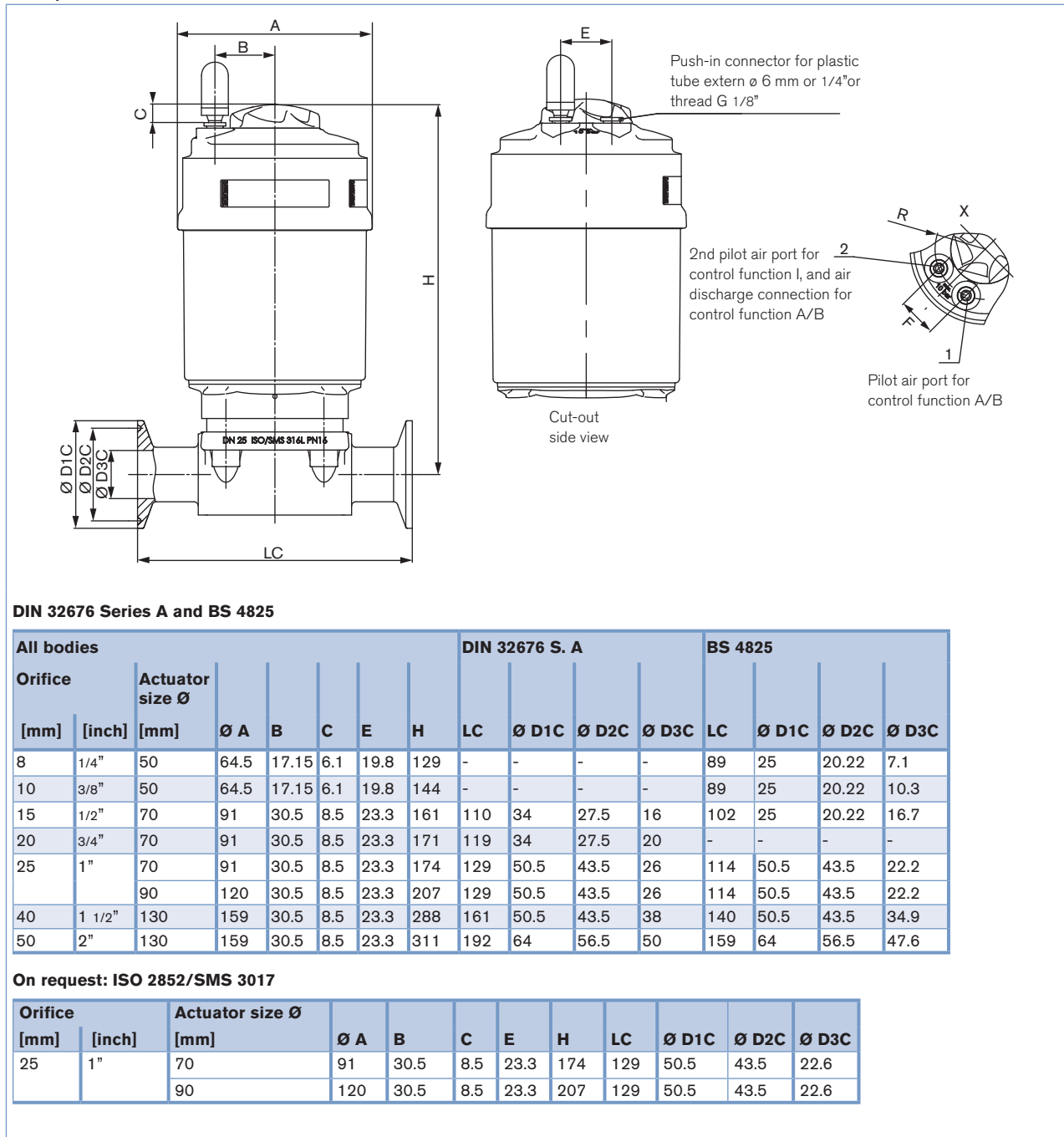

Ordering information for valve system On/Off ELEMENT Type 8801-DF

A **valve system On/Off ELEMENT Type 8801-DF** consists of a **diaphragm valve Type 2103** and a valve actuation system control head **Type 8691/8695** or a pneumatic control unit **Type 8690/8697** (see separate datasheets).

For the configuration of further valve systems please use the "Request for quotation" on p. 13-15. [go to page](#)
 You order two components and receive a complete assembled and certified valve.



A detailed description of the control heads and pneumatic control units is on the next page... →

Ordering information for valve system On/Off ELEMENT Type 8801-DF, *continued*

Control Head / Feedback



More info.



More info.

Type 8691

Actuator size 70/90/130

Type 8695

Actuator size 50

The Control Head Type 8691/ 8695 is optimised for integrated mounting on the 21XX process valve series. The registration of the valve end position is done through a contactless analog position sensor, which automatically recognises and saves the valve end position through the Teach function when starting up. The integrated pilot valve controls single or double-acting actuators. The status of the valve is shown through high power coloured LEDs.

Features

- High power coloured Status-LEDs
- Contactless inductive position sensor
- Pilot valve with manual override
- Teach function for automatic registration of valve positions
- Hygienic stainless steel design
- Easy to clean chemically resistant housing featuring IP65 / IP67, 4X Rating
- AS-Interface or DeviceNet Fieldbus communication

Benefits

- Easy and safe Start-up through Teach function
- Easy process monitoring and error detection through clearly visible high-power coloured LEDs
- High plant availability due to prolonged actuator life boosted by spring chamber ventilation
- Minimised space requirement in the plant piping for more flexibility in plant design

Pneumatic Control Unit / Feedback



More info.



More info.

Type 8690

Actuator size 70/90/130

Type 8697

Actuator size 50

The pneumatic control unit Type 8697/8690 is optimised for integrated mounting on the 21XX process valve series. Mechanical or inductive limit switches register the position of the valve. The integrated pilot valve controls single or double-acting (8690) actuators.

Features

- Visual position indicator
- Mechanical or inductive limit switches for end position registering
- Pilot valve with manual override
- Compact design
- Easy to clean chemically resistant housing featuring IP65 / IP67, 4X Rating
- Optional intrinsically safe version acc. to ATEX

Benefits

- Easy and safe Start-up through Teach function (Type 8697)
- High level of signal reliability thanks to self adjusting limit switches
- Minimised space requirement in the plant piping for more flexibility in plant design

Click on the orange box "More info"... you will come to our website for the resp. product where you can download the data sheet.

Dimensions for valve system On/Off ELEMENT Type 8801-DF [mm]

Dimensions valve system On/Off ELEMENT Type 8801-DF-K (with pneumatic control unit Type 8690)

Welded connection

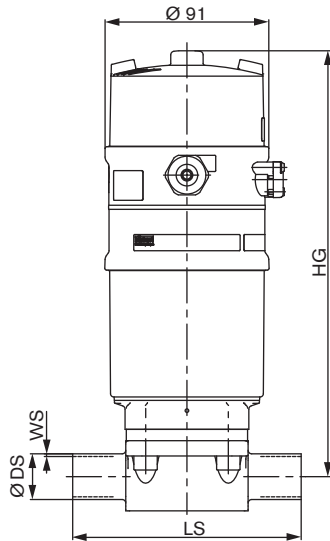

EN ISO 1127/ISO 4200/DIN 11866 S. B and DIN 11850 S. 2/DIN 11866 S. A (SMS 3008 on request)

Orifice		Actuator size Ø [mm]	HG	LS	EN ISO 1127/ ISO 4200/ DIN 11866 S. B		DIN 11850 S. 2/ DIN 11866 S. A		SMS 3008 (on request)	
[mm]	[inch]				Ø DS	WS	Ø DS	WS	Ø DS	WS
15	1/2"	70	224	110	21.3	1.6	19	1.5	-	-
20	3/4"	70	234	119	26.9	1.6	23	1.5	-	-
25	1"	70	237	129	33.7	2.0	29	1.5	25	1.2
		90	270	129	33.7	2.0	29	1.5	25	1.2
40	1 1/2"	130	351	161	48.3	2.0	41	1.5	38	1.2
50	2	130	374	192	60.3	2.0	53	1.5	51	1.2

Clamp connection

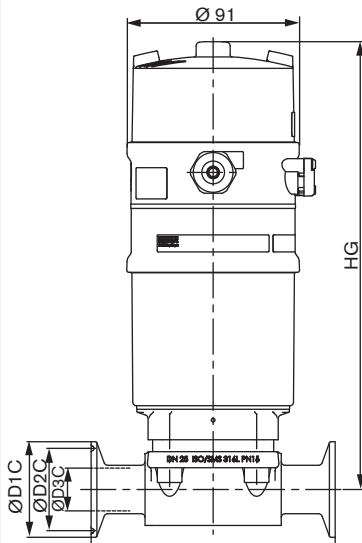

DIN 32676 Series A and BS 4825

Orifice		Actuator size Ø [mm]	HG	DIN 32676 S. A			BS 4825				
[mm]	[inch]			LC	Ø D1C	Ø D2C	Ø D3C	LC	Ø D1C	Ø D2C	Ø D3C
15	1/2"	70	224	110	34	27.5	16	102	25	20.22	16.7
20	3/4"	70	234	119	34	27.5	20	-	-	-	-
25	1"	70	237	129	50.5	43.5	26	114	50.5	43.5	22.2
		90	270	129	50.5	43.5	26	114	50.5	43.5	22.2
40	1 1/2"	130	351	161	50.5	43.5	38	140	50.5	43.5	34.9
50	2	130	374	192	64.0	56.5	50	159	64	56.5	47.6

On request: ISO 2852/SMS 3017

Orifice		Actuator size Ø [mm]	HG	LC	Ø D1C	Ø D2C	Ø D3C
[mm]	[inch]						
25	1"	70	237	129	50.5	43.5	22.6
		90	270	129	50.5	43.5	22.6
40	1 1/2"	130	351	161	50.5	43.5	35.6
50	2	130	374	192	50.5	56.5	48.6

Dimensions for valve system On/Off ELEMENT Type 8801-DF [mm], *continued*

Dimensions valve system On/Off ELEMENT Type 8801-DF-H (with control head Type 8691)

Welded connection

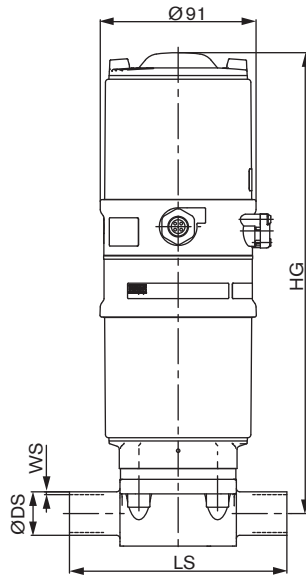

EN ISO 1127/ISO 4200/DIN 11866 S. B and DIN 11850 S. 2/DIN 11866 S. A (SMS 3008 on request)

Orifice		Actuator size Ø [mm]	HG	LS	EN ISO 1127/ ISO 4200/ DIN 11866 S. B		DIN 11850 S. 2/ DIN 11866 S. A		SMS 3008 (on request)	
[mm]	[inch]				Ø DS	WS	Ø DS	WS	Ø DS	WS
15	1/2"	70	257	110	21.3	1.6	19	1.5	-	-
20	3/4"	70	267	119	26.9	1.6	23	1.5	-	-
25	1"	70	1270	129	33.7	2.0	29	1.5	25	1.2
		90	303	129	33.7	2.0	29	1.5	25	1.2
40	1 1/2"	130	384	161	48.3	2.0	41	1.5	38	1.2
50	2	130	407	192	60.3	2.0	53	1.5	51	1.2

Clamp connection

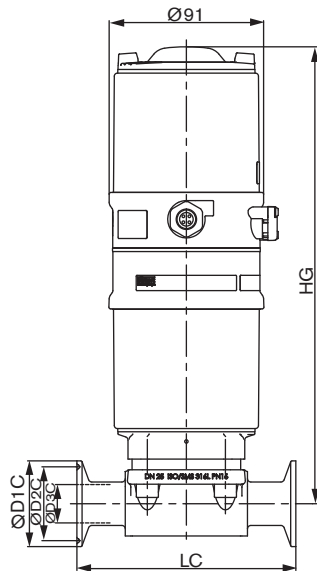

DIN 32676 Series A and BS 4825/ASME BPE

Orifice		Actuator size Ø [mm]	HG	DIN 32676 S. A			BS 4825/ASME BPE				
[mm]	[inch]			LC	Ø D1C	Ø D2C	Ø D3C	LC	Ø D1C	Ø D2C	Ø D3C
15	1/2"	70	257	110	34	27.5	16	102	25	20.22	16.7
20	3/4"	70	267	119	34	27.5	20	-	-	-	-
25	1"	70	1270	129	50.5	43.5	26	114	50.5	43.5	22.2
		90	303	129	50.5	43.5	26	114	50.5	43.5	22.2
40	1 1/2"	130	384	161	50.5	43.5	38	140	50.5	43.5	34.9
50	2	130	407	192	64.0	56.5	50	159	64	56.5	47.6

On request: ISO 2852/SMS 3017

Orifice		Actuator size Ø [mm]	HG	LC	Ø D1C	Ø D2C	Ø D3C
[mm]	[inch]						
25	1"	70	270	129	50.5	43.5	22.6
		90	303	129	50.5	43.5	22.6
40	1 1/2"	130	384	161	50.5	43.5	35.6
50	2	130	407	192	64.0	56.5	48.6

Dimensions for valve system On/Off ELEMENT Type 8801-DF [mm], *continued*

Dimensions valve system On/Off ELEMENT Type 8801-DF-M (with control head Type 8695)

Welded connection

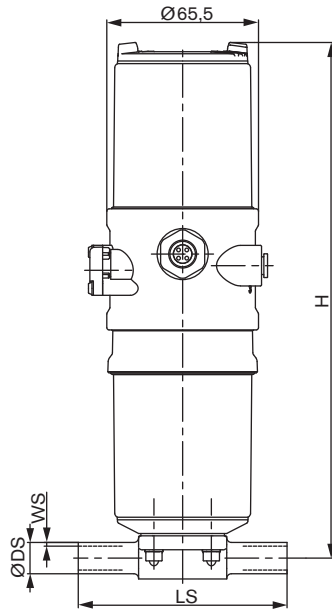

EN ISO 1127/ISO 4200/DIN 11866 Series B and DIN 11850 Series 2/DIN 11866 Series A

Orifice		Actuator size Ø [mm]	H	LS	EN ISO 1127/ ISO 4200/ DIN 11866 S. B		DIN 11850 S. 2/ DIN 11866 S. A	
[mm]	[inch]				Ø DS	WS	Ø DS	WS
08	1/4"	50	223	90	13.5	1.6	-	-
10	3/8"	50	223	90	17.2	1.6	13.0	1.5

DIN 11850 Series 0

Orifice		Actuator size Ø [mm]	H	LS	Ø DS	WS
[mm]	[inch]					
04	-	50	223	90	6	1.0
06	-	50	223	90	8	1.0

Clamp connection

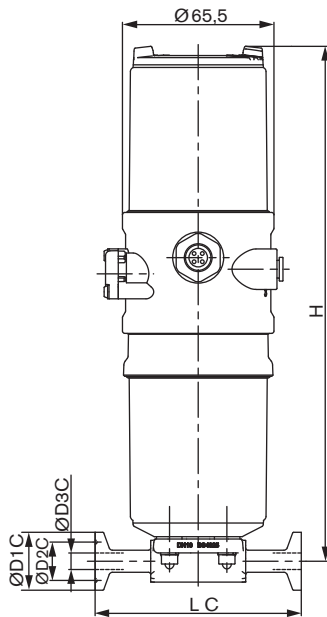

BS 4825

Orifice		Actuator size Ø [mm]	HG	LC	BS 4825		
[mm]	[inch]				Ø D1C	Ø D2C	Ø D3C
8	1/4"	50	223	89	25	20.22	7.1
10	3/8"	50	223	89	25	20.22	10.3

Dimensions for valve system On/Off ELEMENT Type 8801 [mm]

Dimensions valve system On/Off ELEMENT Type 8801 with electrical position indicator Type 8697

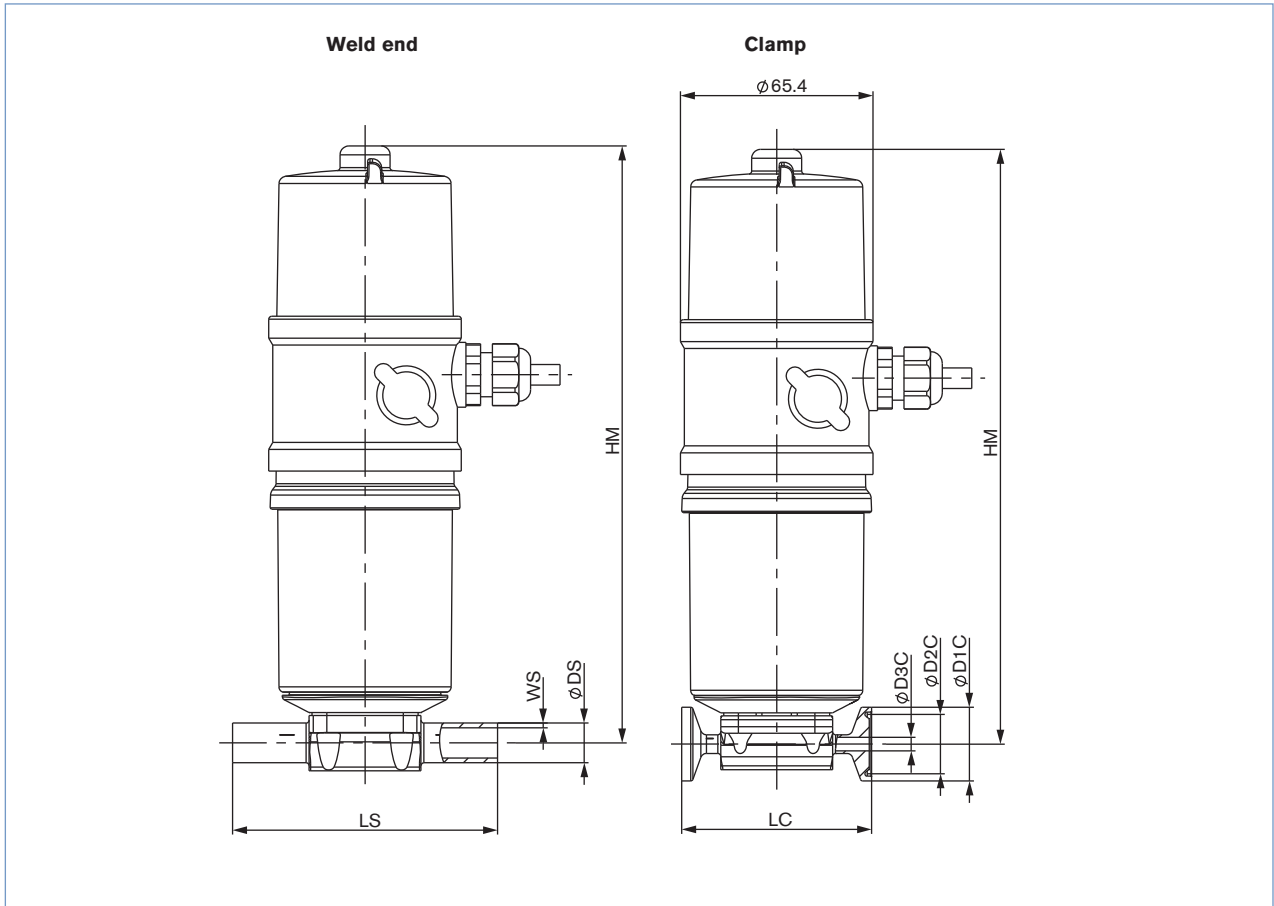

Port connection [mm]	Actuator size [mm]	Connection [mm]												
		Weld end EN ISO 1127 / ISO 4200 / DIN 11866 / Series B				DIN 11850 Series 2 / DIN 1186 Series A				Clamp				
		HM	LS	ØDS	WS	HM	LS	ØDS	WS	HM	LC	D1C	D2C	D3C
8	50	190.9	90	13.5	1.6	-	-	-	-	190.9	89	25	20.22	7.1
10	50	-	-	-	-	190.9	90	17.2	1.6	190.9	89	25	20.22	10.3

Valve features, specification key - Request for quotation

Example

2103 A 15 AB VG SA42 NO06

Specification key

(Please make a choice)

CONTROL FUNCTION

A	normally closed by spring action
B	normally open by spring action
I	double acting

ORIFICE [mm] (diaphragm)

04
06
08
10
15
20
25
32
40
50

SEAL MATERIAL

AB	EPDM in food quality
AD	EPDM
EA	PTFE/EPDM
FF	FKM
EU	advanced PTFE/EPDM in two pieces

BODY MATERIAL

VG	Cast stainless steel 316L/1,4435
----	----------------------------------

VARIABLE CODES

NO06	Int. Mechanical polished Ra=0.8µm
NO18	Int. Mechanical polished Ra=1.6µm
NO16	Int. Electro polished Ra=0.6µm

Standard



DN [mm]	Port connection weld end							
	EN ISO 1127/ ISO 4200 DIN 11866 S. B	SMS 3008	DIN 11850 S. 0	DIN 11850 S. 1	DIN 11850 S. 2 DIN 11866 S. A	DIN 11850 S. 3	BS4825	ASME BPE DIN 11866 S. C
4			SC40 - 6.0x1.0					
6	SA78 - 10.2x1.6		SC41 - 8.0x1.0					SA89 - 3.17x0.56
8	SA40 - 13.5x1.6		SC42 - 10.0x1.0				SODB - 6.35x1.2	SA90 - 6.35x0.89
10	SA41 - 17.2x1.6			SF40 - 12.0x1.0	SD40 - 13.0x1.5	SE40 - 14.0x2.0	SODC - 9.53x1.2	SA91 - 9.53x0.89
15	SA42 - 21.3x1.6	SA58 - 12.0x1.0	SC43 - 18.0x1.5	SF41 - 18.0x1.0	SD42 - 19.0x1.5	SE42 - 20.0x2.0	SODD - 12.7x1.2	SA92 - 12.7x1.65
20	SA43 - 26.9x1.6	SA59 - 18.0x1.0	SC44 - 22.0x1.5	SF42 - 22.0x1.0	SD43 - 23.0x1.5	SE43 - 24.0x2.0	SODE - 19.05x1.2	SA93 - 19.05x1.65
25	SA44 - 33.7x2.0	SA60 - 25.0x1.2	SC45 - 28.0x1.5	SF43 - 28.0x1.0	SD44 - 29.0x1.5	SE44 - 30.0x2.0		SODF - 25.4x1.65
32	SA45 - 42.4x2.0	SA61 - 33.7x1.2	SC46 - 34.0x1.5	SF44 - 34.0x1.0	SD45 - 35.0x1.5	SE45 - 36.0x2.0		
40	SA46 - 48.3x2.0	SA62 - 38.0x1.2	SC47 - 40.0x1.5	SF45 - 40.0x1.0	SD46 - 41.0x1.5	SE46 - 42.0x2.0		SODH - 38.1x1.65
50	SA47 - 60.3x2.0	SA63 - 51.0x1.2	SC48 - 52.0x1.5	SF46 - 52.0x1.0	SD47 - 53.0x1.5	SE47 - 54.0x2.0		SODI - 50.8x1.65

DN [mm]	Port connection Clamp				
	Clamp 34,0 like DIN 32676 S. B (ISO-tube (ISO4200))	DIN 32676 S. A (DIN-tube (DIN11850))	DIN 32676 S. B (ISO-tube (ISO4200))	ASME BPE	BS 4825 (Clamp BS 4825-3, tube BS 4825-1)
8	TC51 - 13.5x1.6 Cl: 34.0	TD40 - 10.0x1.0 Cl: 25.0	TC40 - 13.5x1.6 Cl: 25.0	TG50 - 6.35x0.89 Cl: 25.0	
10	TC41 - 17.2x1.6 Cl: 34.0	TD41 - 13.0x1.5 Cl: 34.0	TC53 - 17.2x1.6 Cl: 25.0	TG01 - 9.53x0.89 Cl: 25.0	
15	TC42 - 21.3x1.6 Cl: 34.0	TD42 - 19.0x1.5 Cl: 34.0	TC52 - 21.3x1.6 Cl: 50.5	TG02 - 12.7x1.65 Cl: 25.0	TH42 - 12.7x1.2 Cl: 25.0
20		TD43 - 23.0x1.5 Cl: 34.0	TC43 - 26.9x1.6 Cl: 50.5	TG03 - 19.05x1.65 Cl: 25.0	TH43 - 19.05x1.2 Cl: 25.0
25		TD44 - 29.0x1.5 Cl: 50.5	TC44 - 33.7x2.0 Cl: 50.5	TG04 - 25.4x1.65 Cl: 50.5	
40		TD46 - 41.0x1.5 Cl: 50.5	TC46 - 48.3x2.0 Cl: 64.0	TG05 - 38.1x1.65 Cl: 50.5	
50		TD47 - 53.0x1.5 Cl: 64.0	TC47 - 60.3x2.0 Cl: 77.5	TG06 - 50.8x1.65 Cl: 64.0	

Note
You can fill out the fields directly in the PDF file before printing out the form.

Valve system On/Off ELEMENT Type 8801-DF – request for quotation

▶ Please fill out and send to your nearest Bürkert facility with your inquiry or order*

Company	Contact person
Customer no.	Department
Address	Tel./Fax
Postcode/town	E-Mail

= mandatory fields to fill out Quantity Required delivery date

Operating data

Pipe line DN PN
 Pipe material
 Process medium
 Type of media Liquid Steam Gas

Valve features

Specification key









2103

(automatically transferred from p. 13)

Surface finish (if not standard) internal µm external µm
 Pilot pressure min. max.
 Atex II 2GD Mechanical

Automation unit features

Click on the orange box "More info"... you will come to our website for the resp. product where you can download the data sheet.

Control Head / Feedback		Pneumatic Control Unit / Feedback	
<input type="checkbox"/> Type 8691  For actuator size 70/90/130 	<input type="checkbox"/> Type 8695  For actuator size 50 	<input type="checkbox"/> Type 8690  For actuator size 70/90/130 	<input type="checkbox"/> Type 8697  For actuator size 50 
<ul style="list-style-type: none"> Inductive position sensor with automatic Teach function Coloured high power LEDs With/without pilot valve for single or double-acting actuators Fieldbus communication Hygienic stainless steel design 		<ul style="list-style-type: none"> visual status indicator Micro- or proximity switches for end position feedback With/ without pilot valve for single or double-acting actuators Optional intrinsically safe version acc. to ATEX / IECEx 	
Pneumatic function <input type="checkbox"/> Single-acting <input type="checkbox"/> Double-acting <input type="checkbox"/> Without pilot valve	Electrical connection <input type="checkbox"/> Cable gland <input type="checkbox"/> M12 connector	Pneumatic function <input type="checkbox"/> Single-acting <input type="checkbox"/> Double-acting (only with 8690) <input type="checkbox"/> Without pilot valve	Number of Position feedback switches <input type="checkbox"/> 1x <input type="checkbox"/> 2x
Communication <input type="checkbox"/> AS-Interface <input type="checkbox"/> DeviceNet <input type="checkbox"/> without	Approvals <input type="checkbox"/> ATEX cat. 3GD, IECEx <input type="checkbox"/> without	Position feedback switches <input type="checkbox"/> Micro switch 24V DC <input type="checkbox"/> Micro switch 50 – 225 V DC/AC (only 8697) <input type="checkbox"/> Inductive switch 3-wire PNP <input type="checkbox"/> Inductive switch 2-wire NAMUR <input type="checkbox"/> Inductive switch 2-wire 24V DC <input type="checkbox"/> without	Electrical connection <input type="checkbox"/> Cable gland <input type="checkbox"/> M12 connector
			Approvals <input type="checkbox"/> ATEX cat. 3GD, IECEx <input type="checkbox"/> ATEX cat. 2DG, IECEx <input type="checkbox"/> without

Continued on next page →

Valve system On/Off Classic Type 8801-DF – request for quotation, *continued*

Certifications

- Attestation of compliance with the order EN-ISO 10204 2.1 (Item-No. 440 788)
- Test report EN-ISO 10204 2.2 (Item-No. 803 722)
- Certification of Conformity for Raw Material EN-ISO 10204 3.1 (Included in delivery)
- FDA and USP compliance

Comment /sketch
