



Tank bottom valve, manually operated, stainless steel block material

- Fully integrated in Bürkert's Process Control Systems
- Monoblock – no welds
- Quality certifications 

Type 3235 can be combined with...



Type 8034
Flow meter



Type 2033
Tank bottom valve



Type 2103
Diaphragm valve

The Bürkert Tank Bottom Valve system is designed for control of ultra pure, sterile, aggressive or abrasive fluids. Enables especially optimal filling and emptying vessels with less dead leg.

The valve body consists of a block with no weld seam, machined out of high quality stainless steel. The tank bottom valve has two welding bevels to ease the welding and valve positioning operations.

The high quality diaphragms separate hermetically critical fluids from the actuator. The manual actuator in PPS or stainless steel can be sterilized.

Technical data			
Orifice	DN 15-100		
Body materials	Stainless steel 1.4435BN2 / ASME BPE Fe < 0,5% / C ≤ 0,03%		
Diaphragm materials	EPDM, PTFE/EPDM, advanced PTFE		
Actuator materials	PPS (PA on request)		
Pilot air ports	Stainless steel 1.4305		
Surface finish	Ra [µm] internal	Ra [µlnch] internal	Ra [Grit #] internal
satin finished	0.5	20	240
electro polished	0.4	16	280
mirror finished ¹⁾	0.25	10	330
Media temperature	-10 °C to +130 °C (briefly up to +150 °C)		
Ambient temperature	+5 °C to +140 °C		
Actuator size < 100 mm	+5 °C to +90 °C (briefly up to +140 °C)		
Actuator size >_100 mm	(-10 °C to +60 °C with PA actuator)		
Port connections			
Weld end acc. to	<ul style="list-style-type: none"> ▪ EN ISO 1127 / ISO 4200 ▪ DIN 11850 RG2 ▪ SMS 3008 ▪ ASME BPE ▪ BS 4825 		
Clamp acc. to	<ul style="list-style-type: none"> ▪ ISO 2852 ▪ ASME BPE ▪ DIN 32676 		

¹⁾Internal Ra < 0.1 µm/4 µlnch/500 Grit: on request

Technical data, continued

Orifice DN diaphragm [mm]	Kv-value water [m ³ /h]	Max. operating pressure (medium) for seal material EPDM and PTFE/EPDM [bar]
8	1.0	10
15	6.0	10
20	11.0	10
25	16.0	10
40	29.0	10
50	50.0	10 ¹⁾
80	160.0	10
100	235.0	5

¹⁾Max. operating pressure 7 bar for bonnet and manual actuator in PPS.

Approvals/certifications

- Certification of Conformity for Raw Material EN-ISO 10204 3.1
- Attestation of compliance with the order EN-ISO 10204 2.1
- Test report EN-ISO 10204 2.2
- 3A Certification on request
- Certification of Conformity for Pickling and Electropolishing Processes
- Certification of Conformity for the Surface Quality DIN4762-DIN4768-ISO/4287/1
- Attestation of compliance with FDA CFR No. 21.177.1550 for PTFE/EPDM and advanced PTFE/EPDM and 21.177.2600 for EPDM
- Test Certification and Conformity Certification for the Final Assembly of Diaphragm Valves
- ISO 9001 Certification

Note: Retrospective manufacturing certification for process diaphragm valves can not be made, therefore please notify when ordering.

Materials

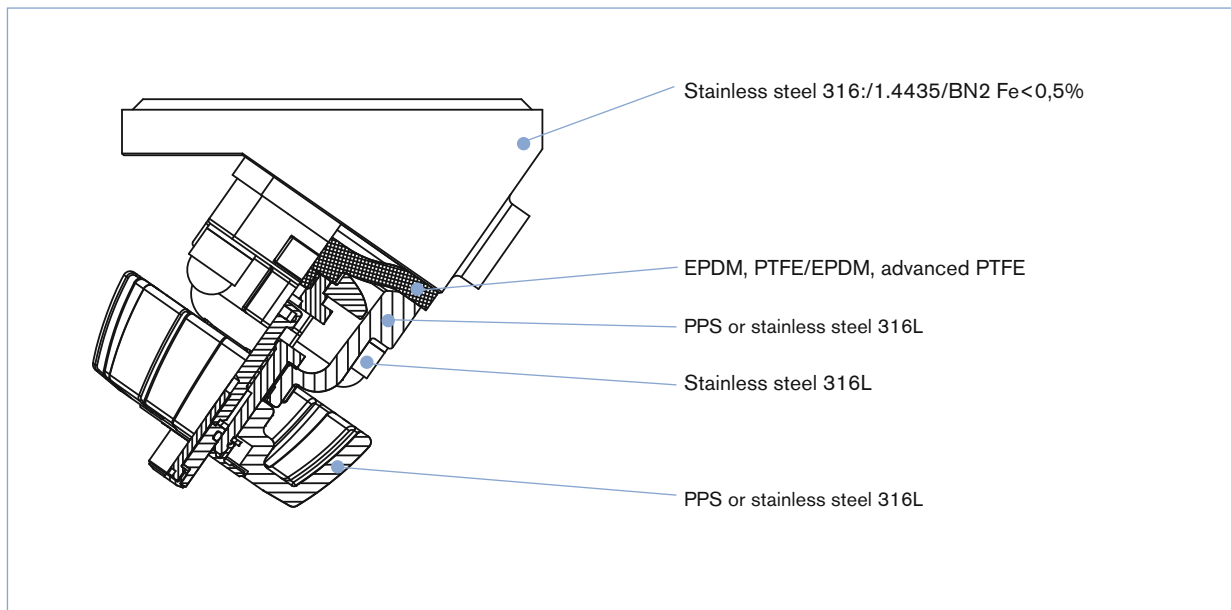

Example of available diaphragm materials

Developed to handle the unique challenges of hygienic and sterile applications, Bürkert offers diaphragms with precise material formula and physical tolerances. Bürkert diaphragms are available in a wide range of materials which have been proven in food & beverage, biotechnology, pharmaceutical and cosmetic industry applications. Diaphragms are tested during development and production to ensure reliability in critical processing environments.

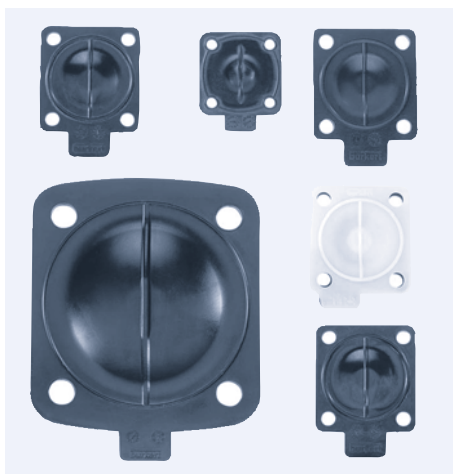

- EPDM (Ethylene Propylene Rubber)
- PTFE/EPDM
- advanced PTFE/EPDM
- FKM
- PTFE/FKM
- NBR

Dimensions [mm]

Body with weld end

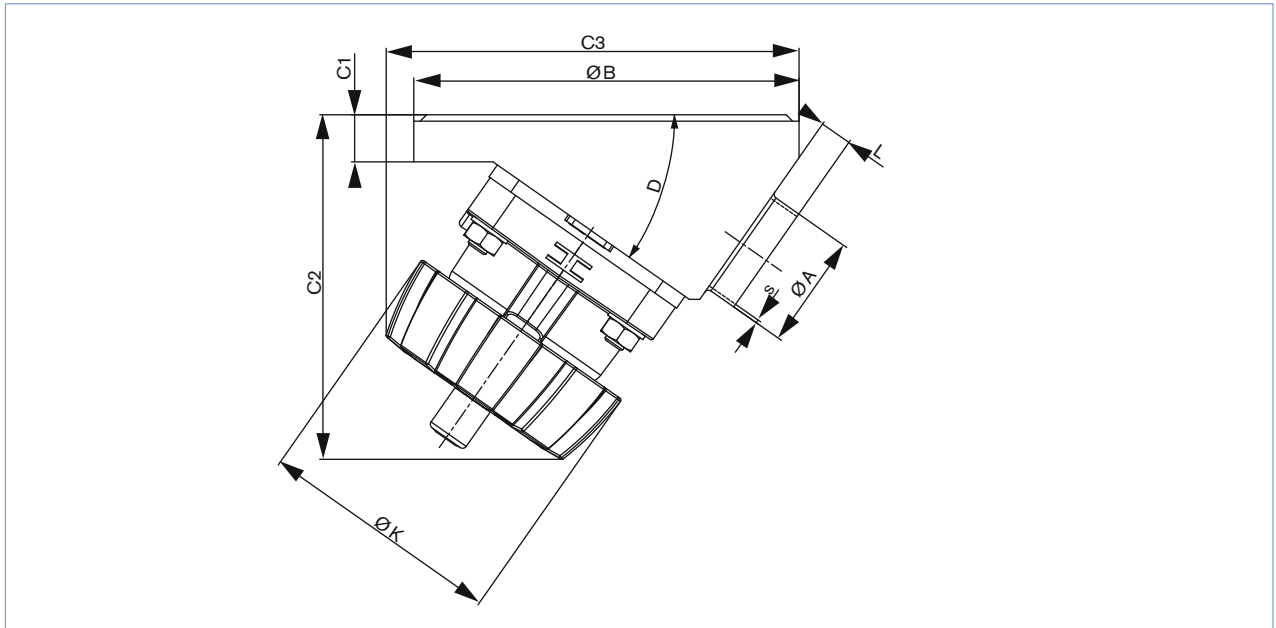

EN ISO 1127 / ISO 4200

Orifice seat [mm]	Port connection [mm]	øA	s	øB	C1	C2	C3	D	øK	L
08	08	13.5	1.6	50	8	65	65	35°	34	5
15	15	21.3	1.6	65	12	103	103	35°	85	3
				85		103	8			
20	20	26.9	1.6	85	12	109	118	35°	85	5.6
25	25	33.7	2	120	16	117	129	35°	85	8
40	32	42.4	2	150	18	147	180	35°	114	20
	40	48.3	2							15
50	50	60.3	2	180	22	162	194	35°	114	12
80	65	76.1	2	225	20	293	345	40°	223	16
	80	88.9	2.3							10

ASME BPE

Orifice seat [mm]	Port connection [mm]	øA	s	øB	C1	C2	C3	D	øK	L
08	08	6.35	0.89	50	8	65	65	35°	34	9
15	15	12.7	1.65	85	12	103	109	35°	85	10
20	20	19.05	1.65	85	12	109	118	35°	85	8
25	25	25.4	1.65	120	16	117	129	35°	85	8
40	40	38.1	1.65	150	18	147	180	35°	114	15
50	40	38.1	1.65	180	22	162	194	35°	114	25
	50	50.8	1.65							15
	65	63.5	1.65							11
80	65	63.5	1.65	225	20	388	422	40°	-	25
	80	76.2	1.65							225

DIN 11850 RG2

Orifice seat [mm]	Port connection [mm]	øA	s	øB	C1	C2	C3	D	øK	L
08	10	13	1.5	50	8	65	65	35°	34	6
15	15	19	1.5	85	12	103	109	35°	85	8
20	20	23	1.5	85	12	109	118	35°	85	7
25	25	29	1.5	120	16	117	129	35°	85	8
40	40	41	1.5	150	18	147	180	35°	114	20
50	50	53	1.5	180	22	162	194	35°	114	15
80	80	85	2.0	225	20	293	345	40°	223	16

Dimensions [mm], continued

Body with Clamp

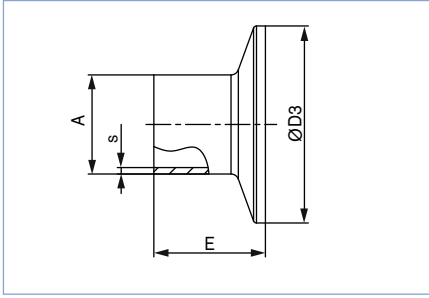

ASME BPE

Orifice		A	s	D3	E
[mm]	[inch]				
08	1/4"	6.35	0.89	25.0	28.6
10	3/8"	9.53	0.89	25.0	28.6
15	1/2"	12.7	1.65	25.0	28.6
20	3/4"	19.05	1.65	25.0	28.6
25	1"	25.4	1.65	50.5	28.6
40	1 1/2"	38.1	1.65	50.5	28.6
50	2"	50.8	1.65	64.0	28.6
65	2 1/2"	63.5	1.65	77.5	28.6
80	3"	76.2	1.65	91.0	28.6
100	4"	101.6	2.11	119.0	28.6

DIN 32676

Orifice [mm]	A	s	D3	E
10	1.5	34.0	18	
15	19	1.5	34.0	18
20	23	1.5	34.0	18
25	29	1.5	50.5	21.5
32	35	1.5	50.5	21.5
40	41	1.5	50.5	21.5
50	53	1.5	64.0	21.5
65	70	2.0	91.0	28

ISO 2852 for pipe ISO 4200

Orifice [mm]	A	s	D3	E
8	13.5	1.6	25.0	28.6
8	13.5	1.6	34.0	28.6
10	17.2	1.6	34.0	28.6
15	21.3	1.6	34.0	28.6
15	21.3	1.6	50.5	28.6
20	26.9	1.6	50.5	28.6
25	33.7	2	50.5	28.6
32	42.4	2	50.5	28.6
40	48.3	2	64.0	28.6
50	60.3	2	77.5	28.6
65	76.1	2	91.0	28.6
100	114.3	2.3	130.0	28.6

SMS

Orifice [mm]	A	s	D3	E
25	25	1.2	50.5	21.5
40	38	1.2	50.5	28.6
50	51	1.2	64.0	28.6

Note

You can fill out the fields directly in the PDF file before printing out the form.

Diaphragm valves – request for quotation

Please fill out and send to your nearest Bürkert facility* with your inquiry or order

Company	Contact person
Customer no.	Department
Address	Tel./Fax
Postcode/town	E-Mail

= mandatory fields to fill out

Quantity

Required delivery date

Operating data

<input type="checkbox"/> Process medium	<input type="text"/>	
<input type="checkbox"/> Type of media	<input type="checkbox"/> Liquid	<input type="checkbox"/> Steam
		<input type="checkbox"/> Gas
<input type="checkbox"/> Flow rate (Q, Q _N , W) ¹⁾	<input type="text"/> nominal	<input type="text"/> unit
<input type="checkbox"/> Temperature at valve inlet	<input type="text"/>	<input type="text"/>
<input type="checkbox"/> Absolute pressure at valve inlet	<input type="text"/>	<input type="text"/>
<input type="checkbox"/> Absolute pressure at valve outlet	<input type="text"/>	<input type="text"/>
<input type="checkbox"/> Steam pressure P _v	<input type="text"/>	<input type="text"/>

¹⁾ standard unit:
Liquid Q = m³/h;
Steam W = kg/h;
Gas Q_N = Nm³/h

Valve features

Specification key

automatically transferred from next page

3235

+

+

Certifications

- Attestation of compliance with the order EN-ISO 10204 2.1
- Test report EN-ISO 10204 2.2
- Certification of Conformity for Raw Material EN-ISO 10204 3.1
- Certification of Conformity for the Surface Quality DIN4762-DIN4768-ISO/4287/1
- Certification of Conformity for Pickling and Electropolishing Processes
- FDA and USP compliance
- 3A certificate

Comment / sketch

*To find your nearest Bürkert facility, click on the orange box →

www.burkert.com

Valve features

Example

15 AB B VI F085 SA42 D050 NO09 + NO17 + AF71

Specification key

Please make a choice

ORIFICE [mm] (diaphragm)

08
15
20
25
40
50
80
100

SEAL MATERIAL

AB	EPDM in food quality
EA	PTFE
FF	FKM, advanced PTFE

PRODUCTION OF BODY

B	Monoblock
---	-----------

BODY MATERIAL

VH	1.4435/AISI 316L
VI	1.4435BN2/ASME BPE

Standard

FLANGE

F050	DN08 (Ø 50 mm)
F085	DN15 (Ø 85 mm)
F085	DN20 (Ø 85 mm)
F120	DN25 (Ø 120 mm)
F150	DN40 (Ø 150 mm)
F180	DN50 (Ø 180 mm)
F225	DN80 (Ø 225 mm)
F300	DN100 (Ø 300 mm)



VARIABLE CODES

Surface finish external	
NO03	Ext. Mirror finished Ra=0.25 µm
NO15	Ext. Electro polished Ra=0.8µm
NO19	Ext. Mech. polished Ra=1.6µm
NO22	Ext. Glassbeaded Ra= 3.2 µm
	Standard
Surface finish internal	
NO07	Int. Mirror finished Ra=0.25 µm
NO14	Int. Satin finished Ra=0.5µm
NO17	Int. Electro finished Ra=0.4µm
NO20	Int. Electro polished Ra=0.25µm
	Standard
Specific angle	
AF71	45° outlet angle

ACTUATOR VERSION

D050	Top PPS, handwheel PPS
D058	Top stainless steel, Handwheel PPS for tank bottom
D085	Grey cast iron, white epoxy painted

PORT CONNECTION

Weld end

Orifice [mm]	EN ISO 1127/ISO 4200	SMS 3008	DIN 11850				BS 4825	ASME BPE	JIS Sanitary	JIS Utility
			Series 0	Series1	Series 2	Series 3				
08	SA40=13.5x1.6		SC42=10x1.0				SODB=6.35x1.2	SA90=6.35x0.89	SA70=13.8x1.65	
15	SA42=21.3x1.6		SC43=18x1.5	SF41=18x1.0	SD42=19x1.5	SE42=20x2.0	SODD=12.7x1.2	SA92=12.7x1.65	SA72=21.7x2.1	
20	SA43=26.9x1.6		SC44=22x1.5	SF42=22x1.0	SD43=23x1.5	SE43=24x2.0	SODE=19.05x1.2	SA93=19.05x1.65	SA76=27.2x2.1	SA80=27.2x2.1
25	SA44=33.7x2.0	SA60=25.0x1.2	SC45=28x1.5	SF43=28x1.0	SD44=29x1.5	SE44=30x2.0	SODF=25.4x1.65	SODF=25.4x1.65	SA73=25.4x1.2	SA81=34x2.0
32	SA45=42.4x2.0		SC46=34x1.5	SF44=34x1.0	SD45=35x1.5	SE45=36x2.0				SA83=42.7x2.0
40	SA46=48.3x2.0	SA62=38.0x1.2	SC47=40x1.5	SF45=40x1.0	SD46=41x1.5	SE46=42x2.0	SODH=38.1x1.65	SODH=38.1x1.65	SA74=38.1x1.2	SA84=60.5x2.0
50	SA47=60.3x2.0	SA63=51.0x1.2	SC48=52x1.5	SF46=52x1.0	SD47=53x1.5	SE47=54x2.0	SODI=50.8x1.65	SODI=50.8x1.65	SA75=50.8x1.5	
65	SA48=76.1x2.0	SA64=63.5x1.6			SD48=70x2.0		SA64=63.5x1.65	SA64=63.5x1.65		
80	SA49=88.9x2.3	SA65=76.1x1.6			SD49=85x2.0		SA65=76.2x1.65	SA65=76.2x1.65		
100	SA39=114.3x2.3	SA66=101.6x2.0			SD50=104x2.0		SA66=101.6x2.11	SA66=101.6x2.11		

Clamp

Orifice DN [mm]	ISO 2852 SMS 3017	ASME BPE	DIN 32676
8	TC51=Clamp 34 - for tube ISO 4200	TG50=Clamp 25 - Tube 6.35x0.89	
10	TC41=Clamp 34 - for tube ISO 4200	TG01=Clamp 25 - Tube 9.53x0.89	TD41=Clamp 34 - Tube 13x1.5
15	TC42=Clamp 34 - for tube ISO 4200	TG02=Clamp 25 - Tube 12.7x1.65	TD42=Clamp 34 - Tube 19x1.5
20	TC43=Clamp 50.5 - for tube ISO 4200	TG03=Clamp 25 - Tube 19.05x1.65	TD43=Clamp 34 - Tube 23x1.5
25	TC44=Clamp 50.5 - for tube ISO 4200	TG04=Clamp 50.5 - Tube 25.4x1.65	TD44=Clamp 50.5 - Tube 29x1.5
40	TC46=Clamp 64 - for tube ISO 4200	TG05=Clamp 50.5 - Tube 38.1x1.65	TD46=Clamp 50.5 - Tube 41x1.5
50	TC47=Clamp 77.5 - for tube ISO 4200	TG06=Clamp 64 - Tube 50.8x1.65	TD47=Clamp 64 - Tube 53x1.5

In case of special application conditions, please consult for advice.

Subject to alteration.
© Christian Bürkert GmbH & Co. KG

1509/7_EU-en_00891855