



Electromotive process valve - 2 way angle-seat shut-off valve

- Fail-safe position by energy storage
- Rapid flow shut off
- Weather and impact resistant design
- Designed according to hygienic demands
- Many diagnostic functions

Type 3320 can be combined with ...



SAFEPOS
energy-pack



Type 3361
Continuous Control
Valve

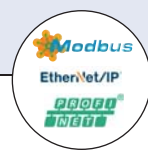

Fieldbus



powered by
EDIP

The innovative Bürkert On/Off process valve Type 3320 is the solution when it comes to shut-off tasks under demanding operating conditions. The electromotive actuator with ball screw moves the swivel plate at a particularly high rate of 6 mm/s to its desired end position. Thereby it reacts almost instantaneously to process signals. If necessary, the safety position can be approached by an optional energy storage in case of power failure. The actuator and shut-off valve are adapted perfectly to each other with closed design and robust surface. This ensures the hygienic requirements of a fast and residue-free cleaning. Harsh environments are no problem for the Type 3320 because of the protection class IP65 / IP67 and its high impact and vibration resistance. Unrivalled cycle life and sealing integrity is guaranteed by the proven self adjusting spindle packing with exchangeable V-seals. The fieldbus suitable for Type 3320 provides many helpful functions for process monitoring, valve diagnostics and predictive maintenance and thus offers the decisive advantage of a modern process automation.

Technical data	
Port size	DN 15 to DN 50
Nominal pressure (max.)	PN25 (valve body)
Port connections	
Thread	G, RC, NPT (EN ISO 228-1, ISO 7/1 / DIN EN 10226-2, ASME B 1.20.1)
Weld ends	EN ISO 1127 / ISO 4200, DIN 11850 R2, ASME BPE, BS 4825-1, SMS 3008
Clamp	DIN 32676 A, DIN 32676 B, ASME BPE, BS 4825
Medium	neutral gases, water, alcohol, oils, fuel, hydraulic mediums, salt solution, alkali solutions, organic solvents, steam
Viscosity	max. 600 mm ² /s
Medium temperature	-10 to +185 °C (seat sealing PEEK/steel) -10 to +130 °C (seat sealing PTFE/steel)
Ambient temperature	-25 °C to +65 °C * (without SAFEPOS energy storage) -25 °C to +55 °C * (with SAFEPOS energy storage) * the allowable value decreases with increasing media temperature
Safety position at power failure	with SAFEPOS energy-pack: opened, closed or free programmable without SAFEPOS energy-pack: blocked in last position
Power supply	24 V DC +/- 10% (max. residual ripple 10%)
Closure time	< 2,3 to 4,3 s (depending on stroke)
Travel speed	6 mm/s
Duty cycle	100%
Protection class	IP65 / IP67
Binary control	0–5 V (log. 0) 10–30 V (log. 1)
Digital control (fieldbus)	EtherNet/IP, Modbus/TCP, Profinet
Approval and Conformity	EGV 1935/2004 (standard) FDA (optional)

Structure and function

The electromotive linear actuator consists of a brushless direct current motor, gears and a threaded spindle. The valve spindle, which is connected to the threaded spindle, transfers the force to the swivel plate. The electronic control system is actuated either via a standard signal (digital) or via a field bus (digital). Optionally there is the energy pack (SAFEPOS energy-pack) for the device. If the supply voltage fails, the energy pack supplies the actuator with the required energy to move the valves into the required position which can be adjusted via a menu.

The valve position can be manually changed in 2 ways. Either over an electrical manual control or over mechanical manual control, if no supply voltage applied. The device can be set and operated either via 2 capacitive buttons and 4 DIP switches. There is also the option of setting the device via the bus Service interface and by using the PC software "Bürkert-Communicator".

The intelligent process valve Type 3320 offers the operator options for process monitoring, valve diagnostics and predictive maintenance. Internal measurements for the operating state are evaluated and, if issued as a warning or error message. This signal, for example, undue environmental and process conditions, functional deviations of components or the state of the energy accumulator. Internal measurements for operating state are evaluated and, possible a warning or error message is issued. This signal indicates, for example, bad environmental and process conditions, functional deviations of components or the state of the energy accumulator.

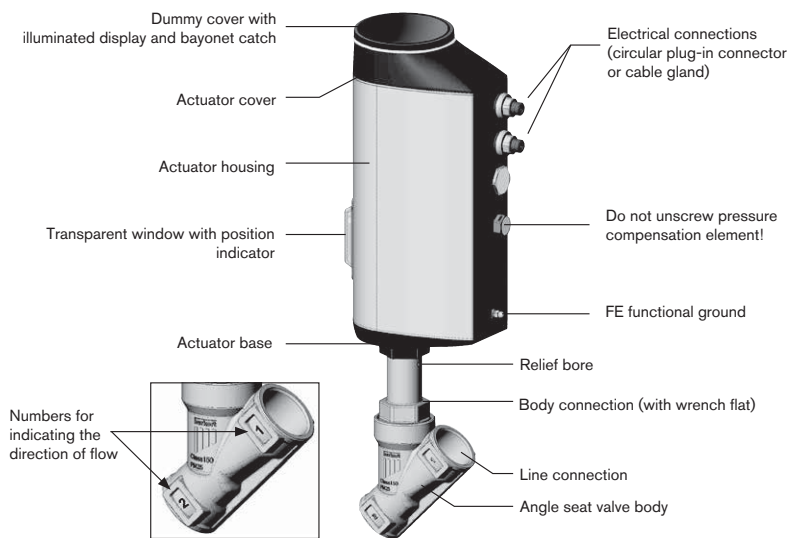

Structure, electromotive angle seat shut-off valve, Type 3320

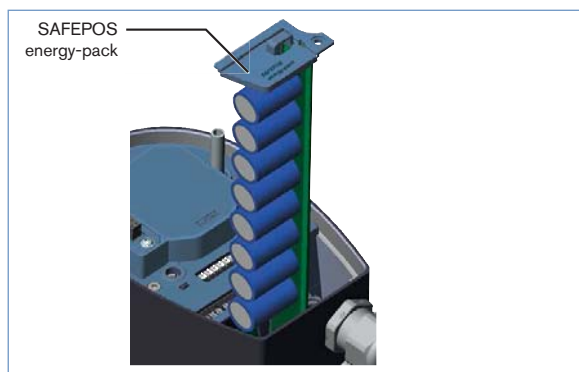

Safety position with energy storage (Option)

The safety starting positions in case of power interruption is realized with the optional energy storage SAFEPOS energy-pack. The desired position (NO/NC) is adjusted from the menu. The energy storage has a lifespan of up to 10 years, depending on the operating conditions. The power of the energy storage is monitored and a warning is displayed to indicate its life is coming to an end. The memory is designed as a plug-in module making it easy to exchange. Without energy storage, the valve remains in the last position.

Controls and indicators

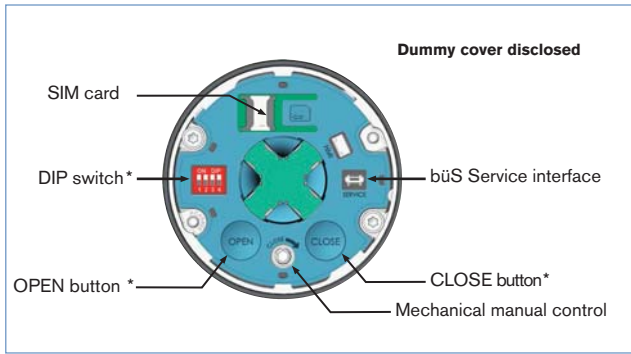

Control elements

The basic functions are operated by 4 DIP switches and 2 pushbuttons. These are located under the dummy cover which can be removed manually by turning. Through the büS service access, the device can also be configured in detail with the Bürkert communicator software. For this, the optional USB-büS interface kit is required.

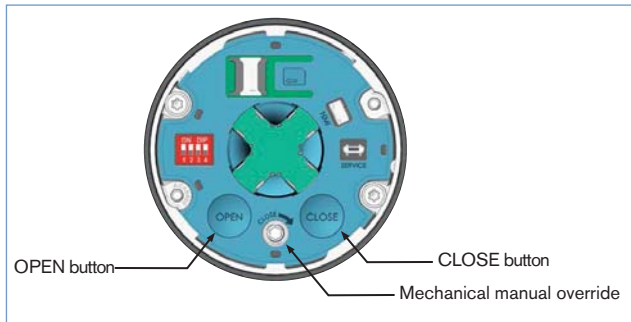

Manual and electrical operation

The manual override for mechanical operation of the valve is located under the dummy cover. Electrical manual override for the procedure is carried out by two buttons below the dummy cover.

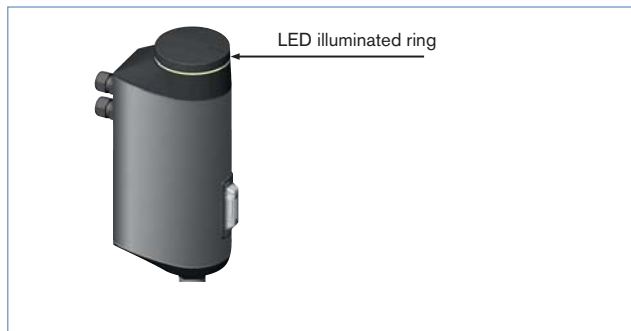

360°- LED Illuminated ring

To display the device status, the valve end position and the operating condition, a visible 360° LED illuminated ring is mounted around the dummy cover. The LED ring lights up, flashes or flashes in one or different colors. Depending on customer requirements 4 different LED modes can be selected (Namur mode, valve mode without warnings, valve mode with warnings, LED off)

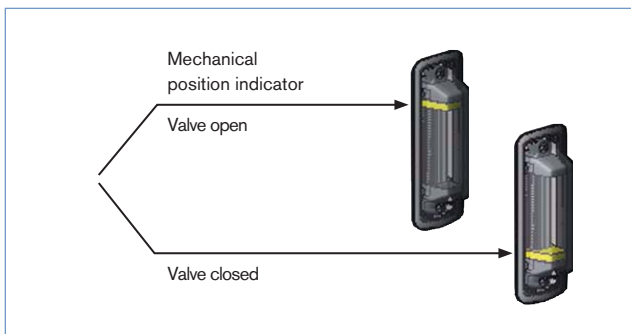

Mechanical position indicator

The mechanical position indicator also indicates when the supply voltage of the current valve position fails

Controls and indicators, continued

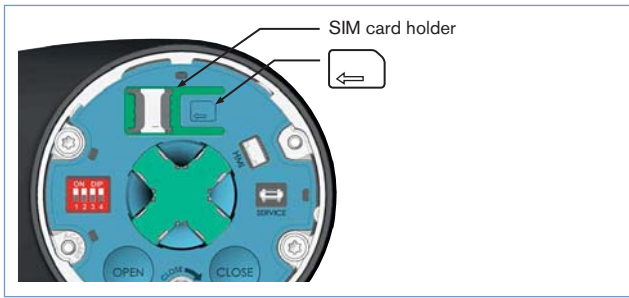
**SIM card as data storage (option)**

With the SIM card optional device-specific values and user settings can be saved and quickly transferred to another device.

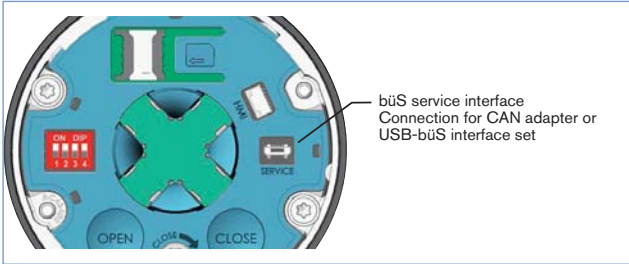
**bÜS service interface**

The bÜS service interface connects the device to the communicator software on a PC, laptop or smartphone. From there, a configuration of the device or failure diagnosis can be performed.

Design and materials view

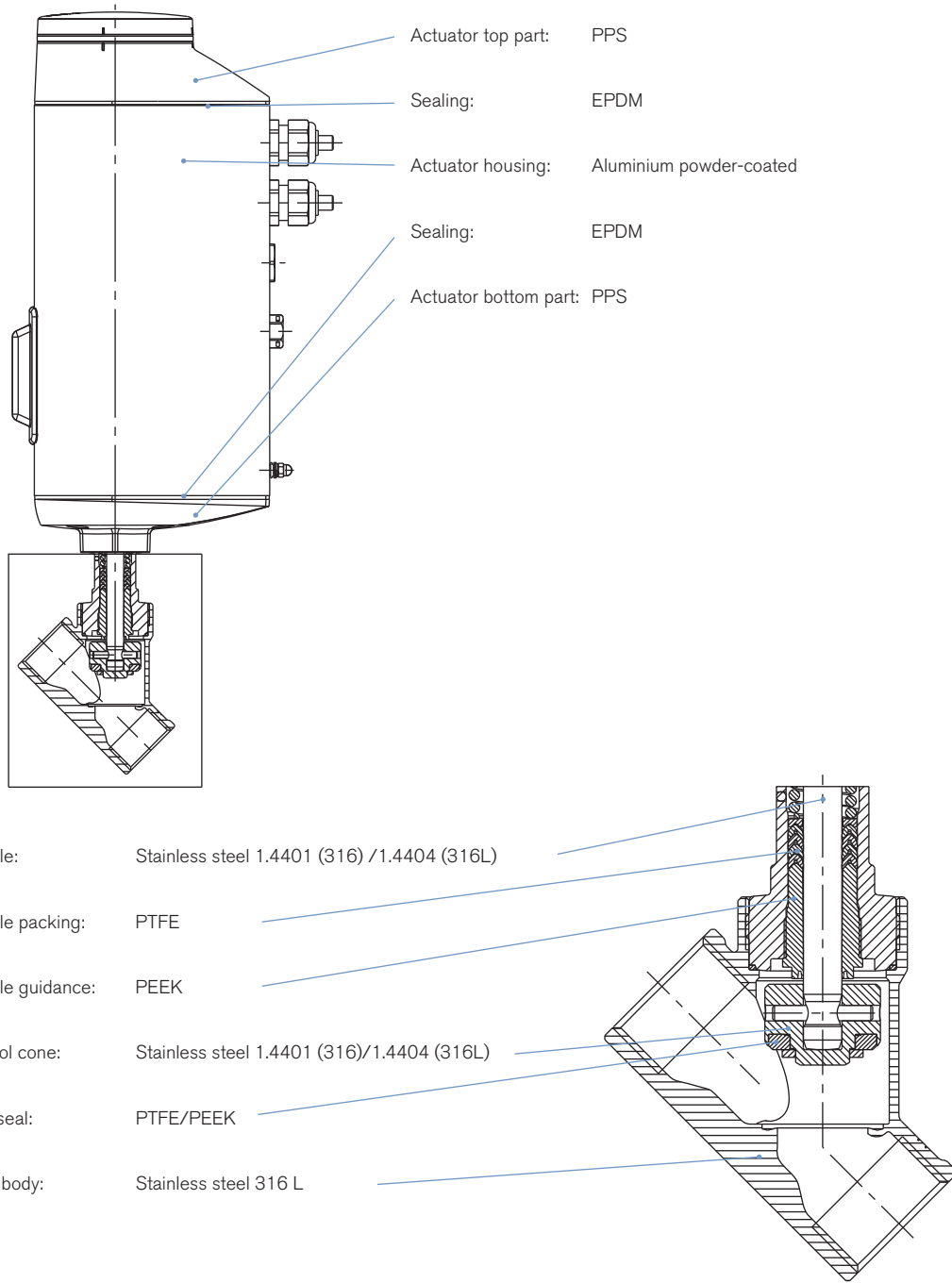

Note: The angle-seat shut-off valve **Type 3320** could be delivered with miscellaneous port connection (thread, weld ends and clamp), there are not represented in the picture, but are made with same material as the valve body.

Technical data

Temperature chart

The maximum allowable ambient temperature and media temperature influence each other. The maximum allowable temperature curves of different device variants can be seen in the temperature chart.

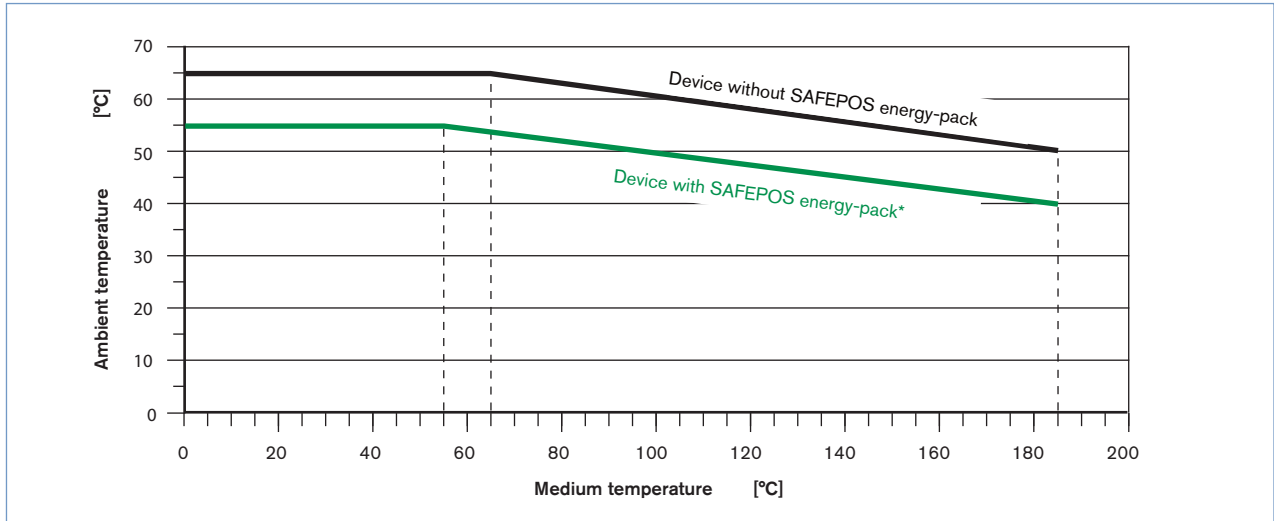

Selection chart for seat sealing

Seat sealing with PTFE is used, if fluid temperature is < 130 °C. If the maximum fluid temperature exceeds 130 °C temporarily or permanently, then PEEK fits best.

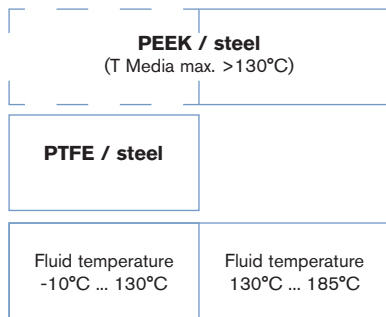

Port connection (tube)		Operating pressure / seat seal		Kv-value water [m³/h]
[mm]	[inch]	PTFE / Stainless steel [bar]	PEEK / Stainless steel [bar]	
15	1/2	16	16	5.0
20	3/4	16	16	11.0
25	1	16	16	18.0
32	1 1/4	16	10	28.0
40	1 1/2	10	8	42.0
50	2	6	5	62.0

Electrical control

Electrical data	
Protection class	3 acc. to DIN EN 61140
Electrical connections	Cable gland, 2 x M20 or 2 circular plug-in connector M12, 5-pin and 8-pin
Operating voltage	24 V DC \pm 10 % max. residual ripple 10 %
Operating current [A]*	max. 3 A including actuator at max. load and charging current of the optional SAFEPOS energy-pack (charging current approx. 1 A)
Lifelong energy storage SAFEPOS energy-pack	up to 10 years (depending on operating conditions)
Electronic without actuator [W]*	min. 2 W, max. 4 W
Control	
Output digital:	current limit 100 mA
Input digital:	0...5 V = log „0“, 10...30 V = log „1“ inverted input reversed accordingly
Communication interface:	Connection to PC via USB bÜS interface set
Communication Software:	Bürkert communicator

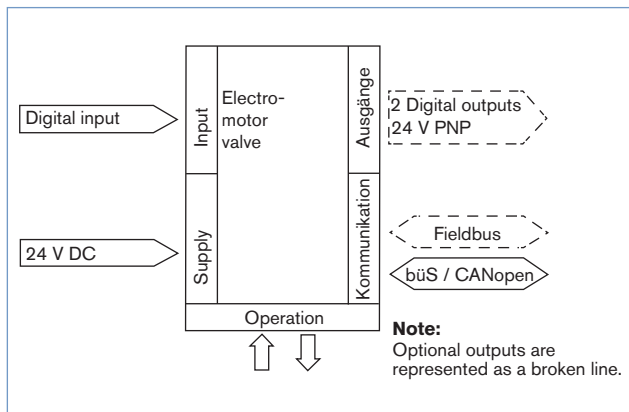
**Electrical control and interface**

The position of the actuator is regulated according to the Position setpoint. The position setpoint value is specified either by an external standard signal (digital) or via a field bus (digital).

Digital Control

For digital control 2 variants are available for the inputs and outputs and the connection interface

Input and output:

* 1 digital input, 2 digital output

Interface:

* cable gland with connection terminal

* M12 circular connectors (optional)

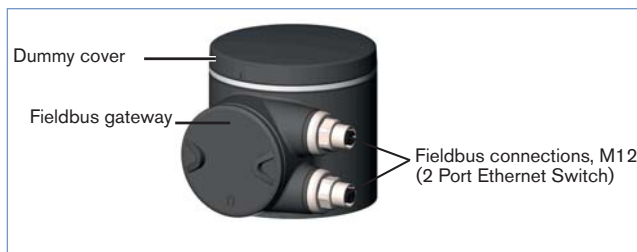
**Fieldbus: EtherNet/IP, PROFINET, Modbus TCP (option)**

The Fieldbus Gateway for EtherNet / IP, PROFINET and Modbus TCP is integrated into a special module. It has 2 fieldbus connections with 4-pin M12 circular connectors. Under the gateway housing cover are the interfaces for the fieldbus connection and status LEDs. If there is a need to be include it in a network then the configuration of the Ethernet can be performed via the web server.

Dimensions [mm] - valve type 3320 and valve system

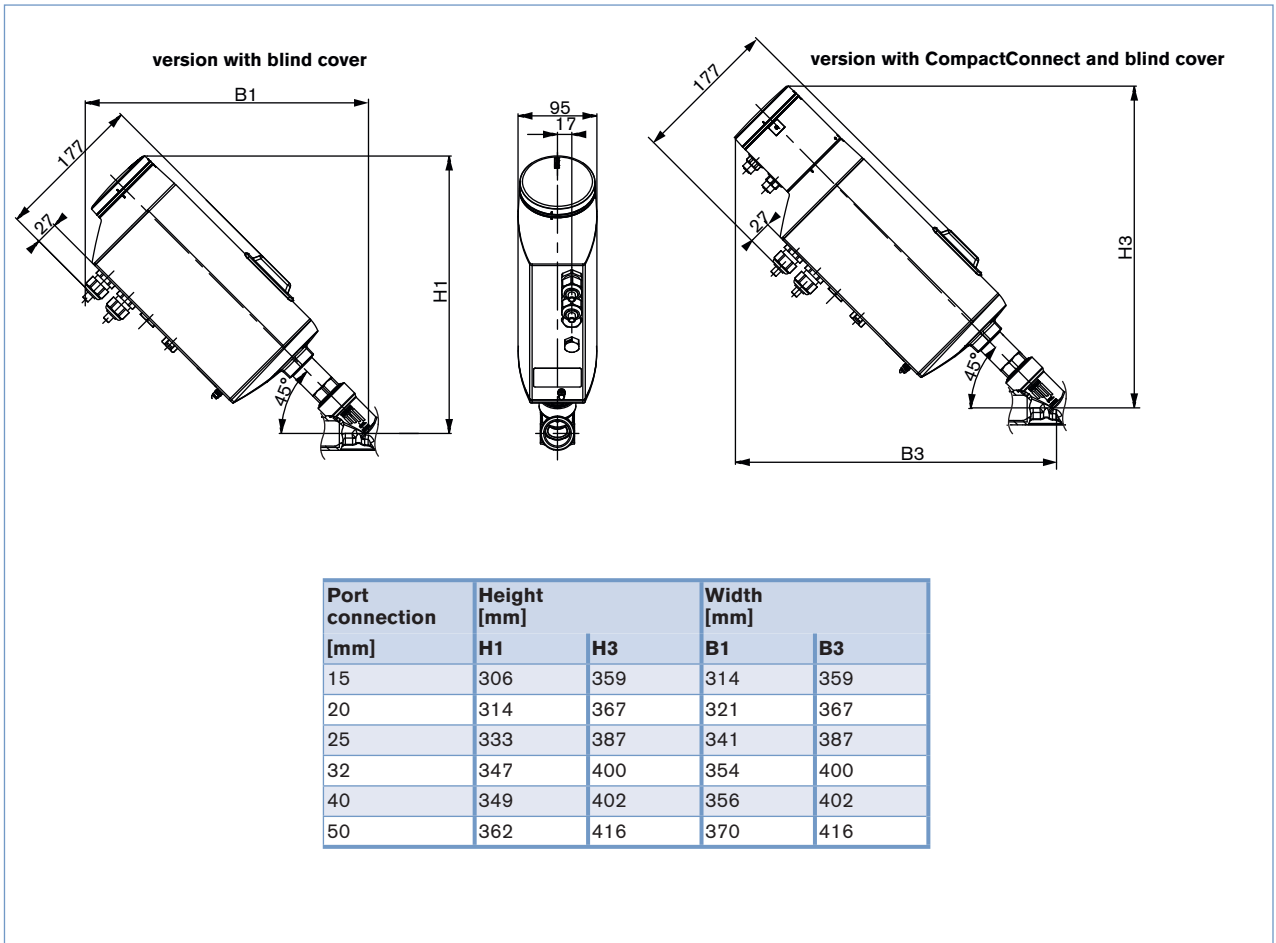

Dimensions [mm] - body valve type 3320

Threaded connection

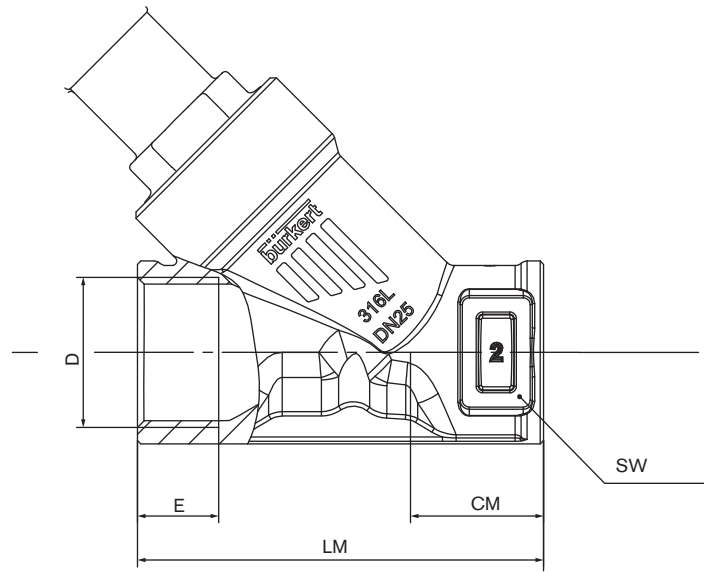

G, RC, NPT (EN ISO 228-1, ISO 7/1 /DIN EN 10226-2, ASME B 1.20.1)

Port size [mm]	CM [mm]	LM [mm]	SW [mm]	G		NPT		RC	
				D [mm]	E [mm]	D [mm]	E [mm]	D [mm]	E [mm]
15	24	65	27	G 1/2	14	NPT 1/2	13.7	RC 1/2	13.2
20	27	75	34	G 3/4	16	NPT 3/4	14.0	RC 3/4	14.5
25	29.5	90	41	G 1	18	NPT 1	16.8	RC 1	16.8
32	36	110	50	G 1 1/4	16	NPT 1 1/4	17.3	RC 1 1/4	19.1
40	35	120	55	G 1 1/2	18	NPT 1 1/2	17.3	RC 1 1/2	19.1
50	45	150	70	G 2	24	NPT 2	17.6	RC 2	23.4

Dimensions [mm] - body valve type 3320

Weld ends port connection

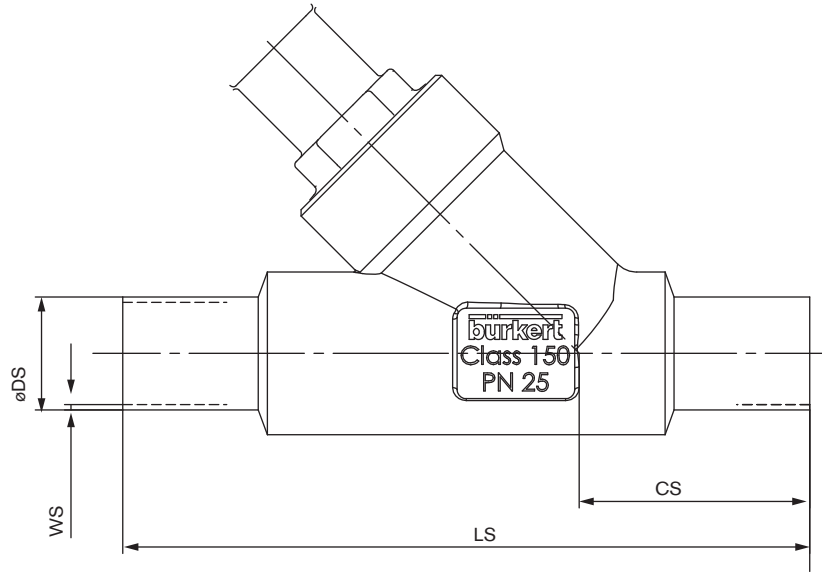

Port size [mm]	EN ISO 1127 Series 1 ISO 4200 DIN 11866 Series B				DIN 11850 R2 DIN 11866 Series A DIN EN 10357 Series A				ASME BPE DIN 11866 Series C			
	CS [mm]	LS [mm]	ØDS [mm]	WS [mm]	CS [mm]	LS [mm]	ØDS [mm]	WS [mm]	CS [mm]	LS [mm]	ØDS [mm]	WS [mm]
15	34	100	21.3	1.6	34	100	19	1.5	34	100	12.7	1.65
20	39	115	26.9	2.0	39	115	23	1.5	39	115	19.05	1.65
25	43	130	33.7	2.0	43	130	29	1.5	43	130	25.4	1.65
32	40	145	42.4	2.0	40	145	35	1.5	-	-	-	-
40	49	160	48.3	2.0	49	160	41	1.5	49	160	38.1	1.65
50	50	175	60.3	2.6	50	175	53	1.5	50	175	50.8	1.65

Dimensions [mm] - body valve type 3320

Clamp connection

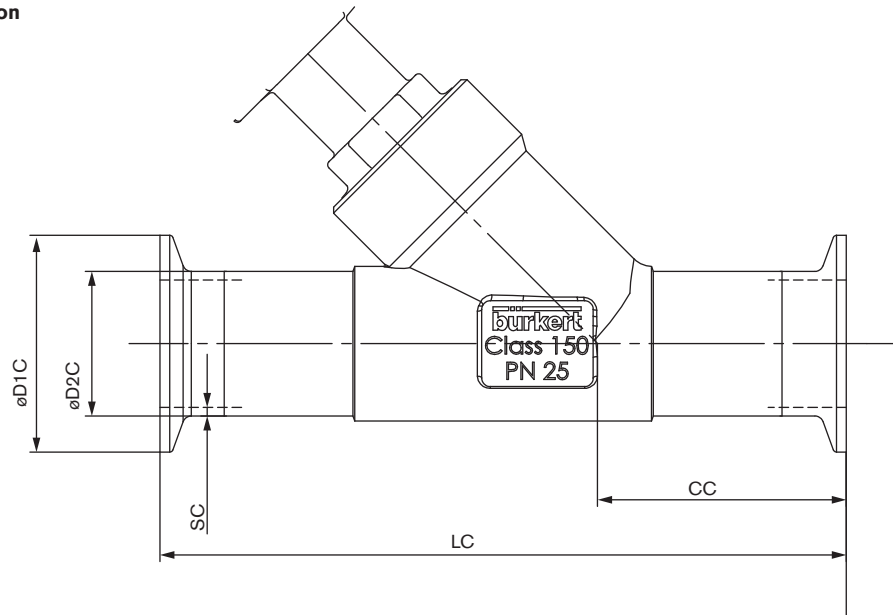

Port size [mm]	Clamp: DIN 32676 Series B Tube: EN ISO 1127 Series 1 ISO 4200 DIN 11866 Series B					Clamp: ASME BPE DIN 32676 Series C Tube: ASME BPE DIN 11866 Series C					Clamp: BS 4825-3 Tube: BS 4825-1					Clamp: DIN 32676 Series A Tube: DIN 11850 Series 2 DIN 11866 Series A DIN EN 10357 Series A				
	LC	CC	ØDC1	ØDC2	SC	LC	CC	ØDC1	ØDC2	SC	LC	CC	ØDC1	ØDC2	SC	LC	CC	ØDC1	ØDC2	SC
15	156	49.0	50.5	21.3	1.6	130	49.0	25.0	12.7	1.65	130	49.0	25.0	12.7	1.20	130	49.5	19	34.0	1.5
20	150	56.5	50.5	26.9	1.6	150	56.5	25.0	19.05	1.65	150	56.5	25.0	19.05	1.20	150	57.0	23	34.0	1.5
25	160	58.0	50.5	33.7	2.0	160	58.0	50.5	25.4	1.65	160	58.0	50.5	25.4	1.65	160	58.5	29	50.5	1.5
32	200	57.5	50.5	42.4	2.0	-	-	-	-	-	-	-	-	-	-	180	58.0	35	50.5	1.5
40	200	69.0	64.0	48.3	2.0	200	69.0	50.5	38.1	1.65	200	69.0	50.5	38.1	1.65	200	69.5	41	50.5	1.5
50	230	77.5	77.5	60.3	2.6	230	77.5	64.0	50.8	1.65	230	77.5	64.0	50.8	1.65	230	78.0	53	64.0	1.5

Valve system – request for quotation

Note

You can fill out the fields directly in the PDF file before printing out the form.

▶ Please fill out and send to your nearest Bürkert office* with your inquiry or order

Company:	Contact person:
Customer no.:	Department:
Address:	Tel./Fax.:
Postcode/town:	E-Mail:

= mandatory fields to fill out

Quantity:

Required delivery date:

Operating data

Pipe line	DN <input type="text"/>	PN <input type="text"/>
Pipe Material	<input type="text"/>	
<input checked="" type="checkbox"/> Process medium	<input type="text"/>	
<input checked="" type="checkbox"/> Type of medium	<input type="checkbox"/> Liquid	<input type="checkbox"/> Steam <input type="checkbox"/> Gas

Valves features

Cone seal material	<input type="checkbox"/> PTFE/Stainless steel	<input type="checkbox"/> PEEK / Stainless steel
Nominal pressure	PN <input type="text"/>	
Seat size (orifice)	DN <input type="text"/>	
Type of connection	<input type="checkbox"/> Threaded	<input type="checkbox"/> Welded <input type="checkbox"/> Clamp
Specify connection	<input type="text"/>	
Control function	<input type="checkbox"/> with energy storage (delivey status NO)	<input type="checkbox"/> without energy storage (blocked in last position)
	<input type="checkbox"/> with energy storage (delivey status NC)	

Valve system – request for quotation, *continued*

Control unit features

Communication

- Binary
- Digital (Fieldbus)
- 1 binary IN
- Ethernet / IP
- 2 binary OUT
- Profinet
- Modbus TCP

Electrical connection

- Cable gland (without Fieldbus)
- Multipol

SIM card

- with
- without

Item no. (if known):

Bemerkungen

DTS 1000295547 EN Version: A Status: RL (released | freigegeben | valide) printed: 16.11.2016