

3/2 and 5/2 way valves
Flow rates: 130 l/min; M5 and Legris \varnothing 4 mm

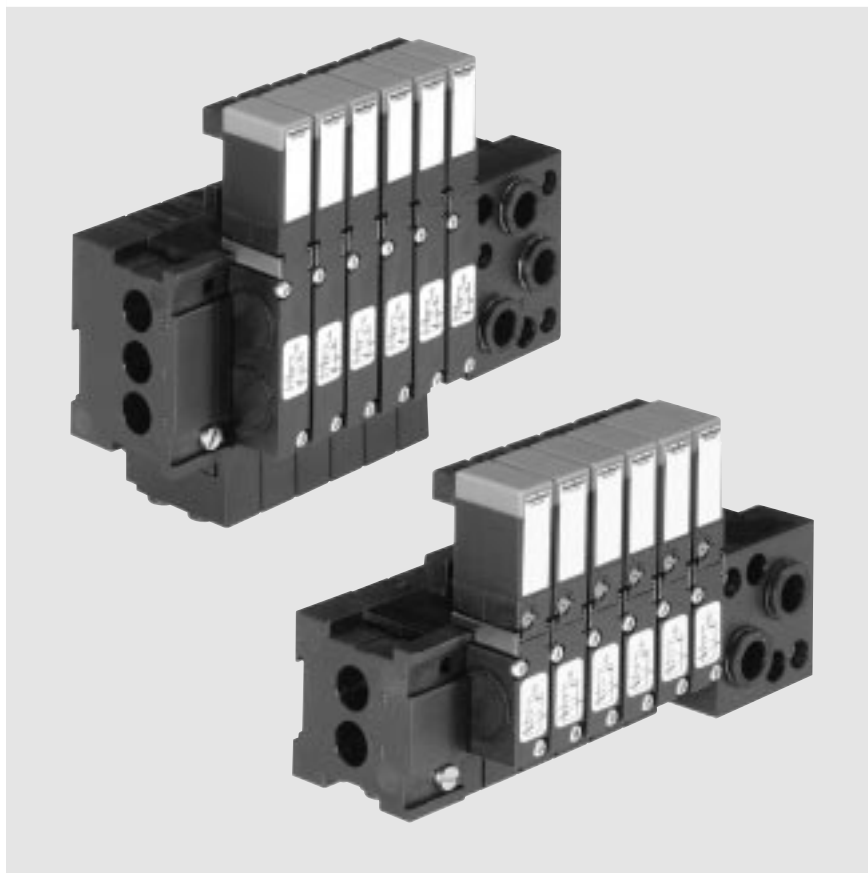

Advantages / Benefits

- ▶ EEx-ia-II C T6 approval
- ▶ Optimal system solutions due to the high level of modularity
- ▶ Long service life even with non-lube conditions
- ▶ Pre-tested and supplied "easy to connect"
- ▶ No individual valve wiring
- ▶ Separate electrical circuits for the electronics and the valves.
- ▶ Field bus compatible
- ▶ Low installation costs
- ▶ Corrosion resistant

Design/Function

Types 6510/6511 Ex are with high switch reliability diaphragm valves in 3/2 and 5/2 way versions.

The valve consists of a diaphragm reinforcement as main valve and a 10 mm rocker solenoid valve with DC-coil as pilot.

The valve module system is suitable for a wide variety of complex control applications, with the logical, modular construction in respect of its electrical and fluid interfaces.

Types 6510 and 6511 are expandable and preferably suitable for valve blocks with plug connection at the back, or in front by easily turning the pilot valve 180° .

The electrical connections can be made either via common connections, Multipole or field bus interfaces.

The operation principle allows to switch high pressures in spite of small electrical performances.

The valve range allows many different application possibilities with regard to controller, dimensions, flow and performance. The valves can easily be interchanged.

The housing and connecting modules are made of high quality thermoplastic, and are easy to connect or disconnect with the integrated latching technique.

The block assembly takes place with use of the pneumatic modules MP01 (for type 6510) and MP02 (for type 6511) through integrated lock technology and screwing.

Applications

For integration as control valve on process valve
In hazardous area

- Food and beverage
- Pharmaceutical processing equipment
- Cosmetic processing equipment
- Textile dyeing / drying machines
- Sterilizers
- Water treatment / processing equipment
- Pulp and paper processing equipment

burkert
Easy Fluid Control Systems

avroara-arm.ru
+7 (495) 956-62-18

Technical data type 6510/6511 Ex

Circuit function

C 3/2 way valve type 6510,
in de-energized position
port 2 exhausted

Symbol

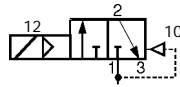

Circuit function

H 5/2 way valve type 6511,
in de-energized position
pressure port 1 connected to
port 2, port 4 exhausted

Symbol

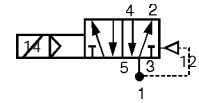

Specifications

Circuit function	Orifice [mm]	Flow rate ¹⁾ QnN-value air [l/min]	Pressure range ²⁾ [bar]	All port connections at the back of the valve	Service ports 2 and 4 at the pneumatic module	Supply ports 1/3/5 at the connection module
C (3/2)	2,5	130	2,5 - 7	sub-base	M5 or plug-in coupling ø 4 mm	G 1/8 or plug-in coupling ø 8 mm
H (5/2)	2,5	130	2,5 - 7	sub-base		

¹⁾ Measured at 6 bar input pressure and 1 bar pressure drop at the valve and at +20°C.

²⁾ All pressure data as overpressure to ambient atmospheric pressure.

Valve specifications

Valve body	Polyamide (PA)
Sealing material	FPM and NBR
Media	Lubricated or unlubricated compressed air, neutral gases
Media temperature	-10 up to +50 °C
Ambient temperature	-10 up to +60 °C
Response times ³⁾	
Open (On)	23 ms
Close (Off)	27 ms
• Port connections at the valve	Sub base
• Supply ports 1/3/5 at the connection module	Threaded port G 1/8 or plug-in coupling ø 8 mm
• Service ports 2/4 at the pneumatic module	Threaded port M5 or plug-in coupling ø 4 mm

³⁾ Measured at connection 2; time from electrical switching to pressure increase to 90% (opening) or pressure drop to 10% (closing) of operational pressure (6 bar).

Solenoid specifications

Operating voltage	24 V/DC
Voltage tolerance	±10 %
Electrical power consumption	0.5 W
Duty cycle	100 % continuously rated
Electr. connection	Rectangular plug, 2 pole on top or downwards
Rating	IP 40 (with rectangular plug connection)
Ex-approval	EEx ia IIC T6

Electrical specifications

Power supply only from certified intrinsically safe circuits with following max. valves:	
Explosion group	IIC
Max. safety voltage	U = 28 V
Max. safety current	I = 115 mA
Consumption of energy for block mounting	P = 0.7 W (ambient temperature +40 °C)
Consumption of energy for single mounting	P = 0.7 W (ambient temperature +55 °C) P = 0.8 W (ambient temperature +50 °C)

Installation

- Preferably on multistation module assembly
- Block assembly on MP01 or MP02
with DIN/EN-rail 50045

Mounting position any, preferably solenoid
system upright

Dimensions [mm]

Type 6510 (3/2-way valve) with sub-base connection

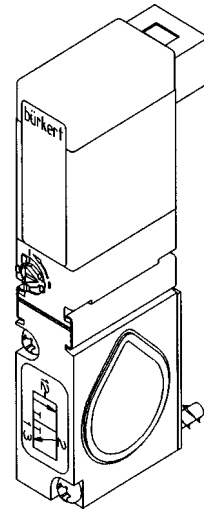
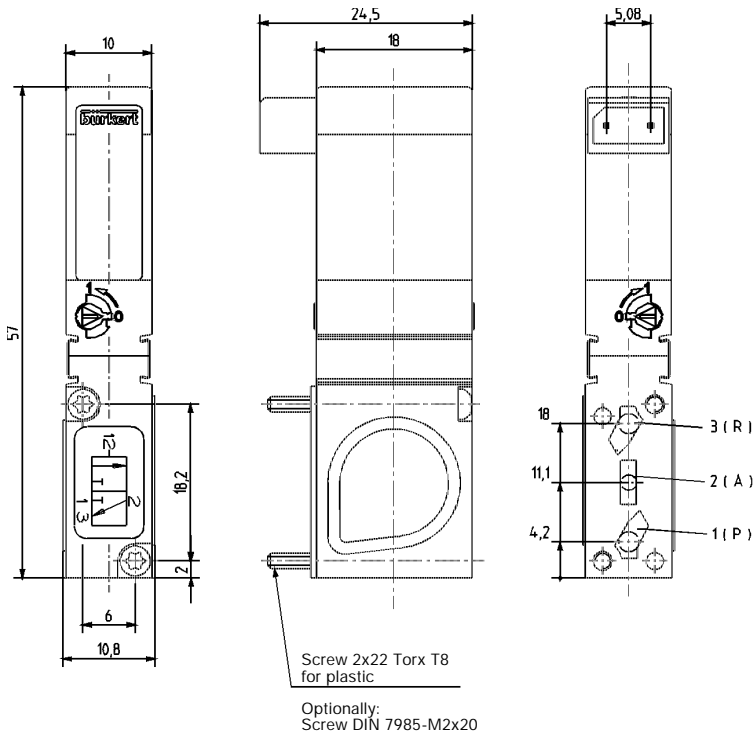

Version 1

Rectangular plug at the back; compatible with the multipole block assembly for multipole and field bus wiring.

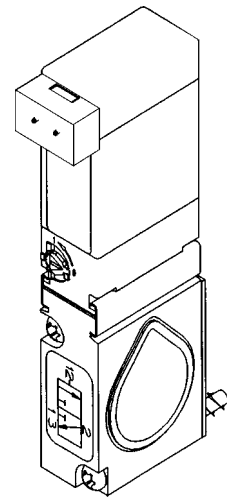

Version 2

Rectangular plug in front; for simple wiring with cable plugs.

On Request

Type 6511 (5/2-way valve) with sub-base connection

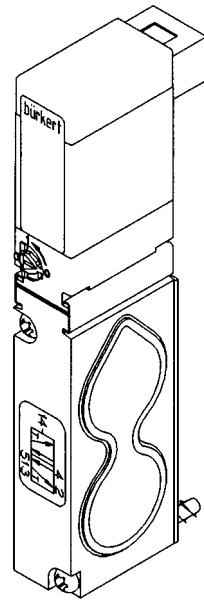
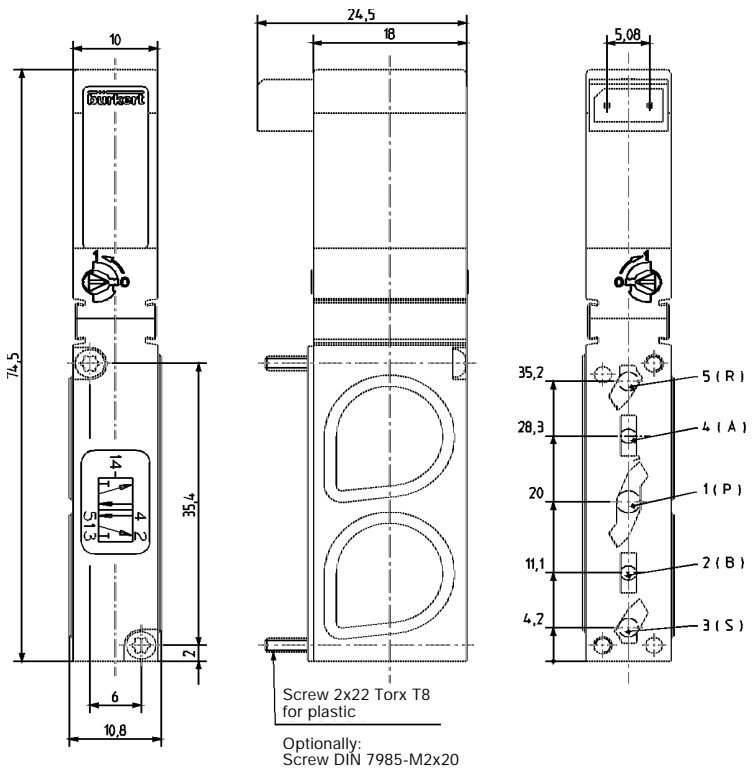

Version 1

Rectangular plug at the back; compatible with the multipole block assembly for multipole and field bus wiring.

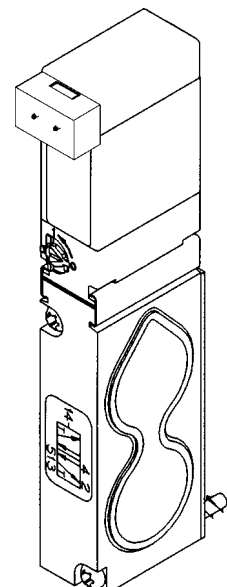

Version 2

Rectangular plug in front; for simple wiring with cable plugs.

On request

Multi-Way Valves for Pneumatics

servo-assisted, extendable, 10 mm wide

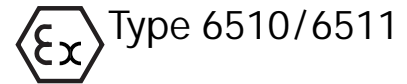

Ordering chart type 6510/6511 (other versions on request)

Scope of delivery: All valves with NBR and FPM seal material; sub-base version with mounting screws and sub-base seal; with rectangular plug on top; **without electrical plug** (see accessories)

Type 6510 and 6511

Circuit function/type	Orifice [mm]	Flow rate QNn value air [l/min]	Pressure range [bar]	Voltage/frequency [V/Hz]	Electrical power consumption [W]	Item No. with manual override	Item No. without manual override
C/Type 6510	2.5	130	2,5 - 7	24/DC	0.5	139 411 R	139 412 J
H/Type 6511	2,5	130	2,5 - 7	24/DC	0.5	139 413 K	139 414 L

Ordering chart pneumatic modules MP01 (for type 6510) and MP02 (for type 6511)

Module type MP01, 3/2-way (type 6510)	Item No.	Modules type MP01, 3/2-way (type 6510)	Item No.
Connector module left, G 1/8"	132 408 Y		
Connector module left, NPT 1/8"	133 464 Q	Basic module 2 valves basis, M5	132 413 C
Connector module left, plug-in coupling ø 8 mm	132 411 A	Basic module 2 valves basis, plug-in coupling ø 4 mm	132 414 D
Terminating module without supply port, left	132 405 M	Basic module 3 valves basis, M5	132 415 E
Connector module right, G 1/8"	132 409 Z	Basic module 3 valves basis, plug-in coupling ø 4 mm	132 416 F
Connector module right, NPT 1/8"	133 465 R	Basic module 12 valves basis, M5	132 417 G
Connector module right, plug-in coupling ø 8 mm	132 412 B	Basic module 12 valves basis, plug-in coupling ø 4 mm	132 418 R

Module type MP02, 5/2-way (type 6511)	Item No.	Module type MP02, 5/2-way (type 6511)	Item No.
Connector module left, G 1/8"	135 005 J		
Connector module left, NPT 1/8"	134 742 X	Basic module 2 valves basis, M5	135 010 J
Connector module left, plug-in coupling ø 8 mm	135 006 K	Basic module 2 valves basis, plug-in coupling ø 4 mm	135 011 F
Terminating module without supply port, left	135 007 L	Basic module 3 valves basis, M5	135 012 G
Connector module right, G 1/8"	135 008 V	Basic module 3 valves basis, plug-in coupling ø 4 mm	134 744 Z
Connector module right, NPT 1/8"	134 743 Y	Basic module 12 valves basis, M5	135 013 H
Connector module right, plug-in coupling ø 8 mm	135 009 W	Basic module 12 valves basis, plug-in coupling ø 4 mm	135 014 A

Ordering chart accessories

Version	Characteristics	Item No.
Blanking plug	for plug-in coupling ø 4 mm	781 664 A
Blanking screw	G 1/8"	631 019 Y
Silencer	G 1/8"	780 779 Y
Covering plate, complete	for left-free valve spaces on MP01	642 148 R
Covering plate, complete	for left-free valve spaces on MP02	642 156 H
Rectangular plug connector, straight, with 3 m cable	for electrical single connection of valves	133 486 F
Rectangular plug connector, with flying leads, 300mm length	for individual single wiring	644 068 N

Block and wall mounting valves type 6510 (3/2 way) with pneumatic modules type MP01

Block design with connector module on the right and left (2 supply ports); block assembly with rectangular plug at the back (Version 1) and in front (Version 2) possible:
rectangular plug connector necessary (see accessories)!

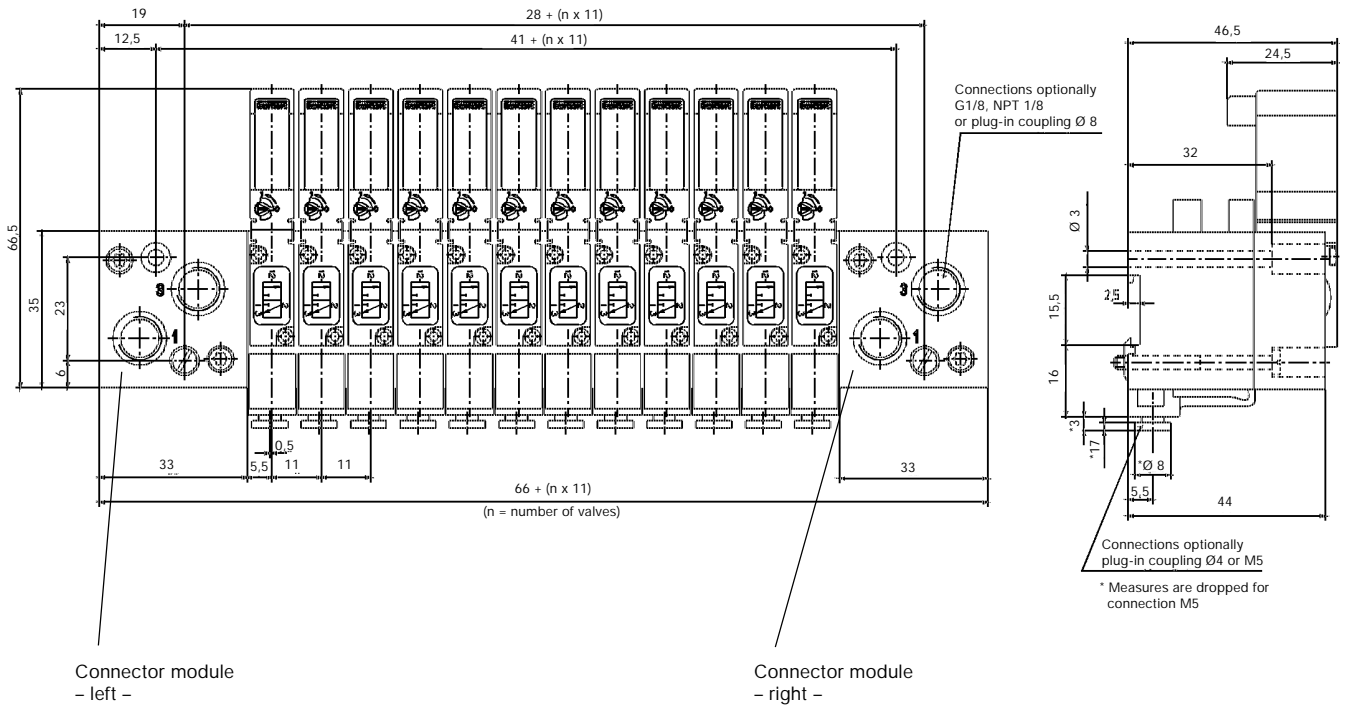

Block design with connector module on the right (1 supply port) and terminating module on the left; Block assembly with rectangular plug at the back (Version 1) and in front (Version 2) possible:
rectangular plug connector necessary (see accessories)!

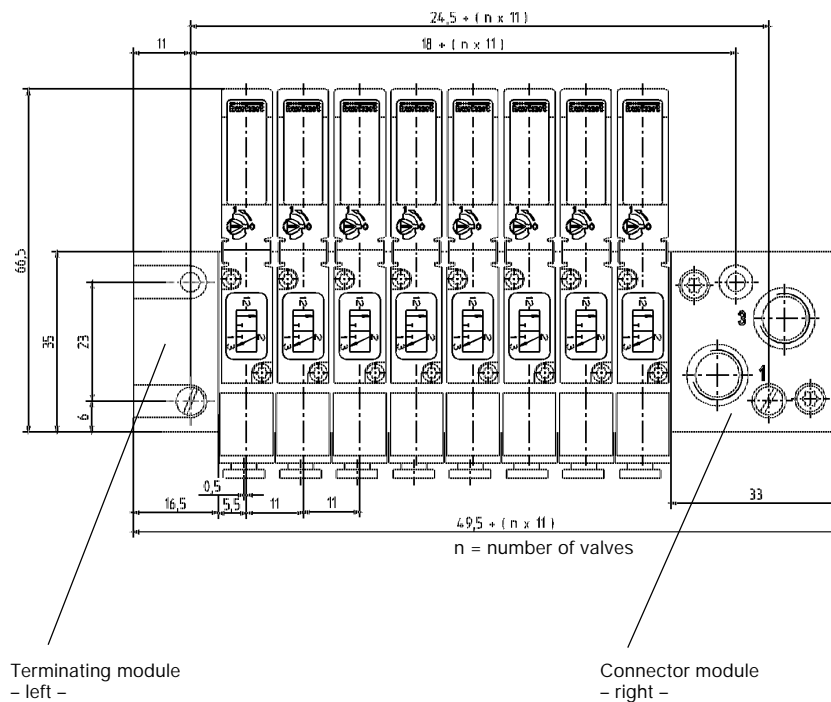

Specifications on design on a modular valve block, please see data sheet Customized Pneumatic Systems Solutions.

Multi-Way Valves for Pneumatics

servo-assisted, extendable, 10 mm wide

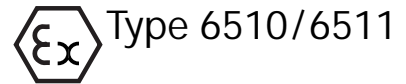

Block and wall mounting valves type 6511 (5/2 way) with pneumatic modules type MP02

Block design with connector modules on the right and left (2 supply ports); block assembly with rectangular plug at the back (Version 1) and in front (Version 2) possible:
rectangular plug connector necessary (see accessories)!

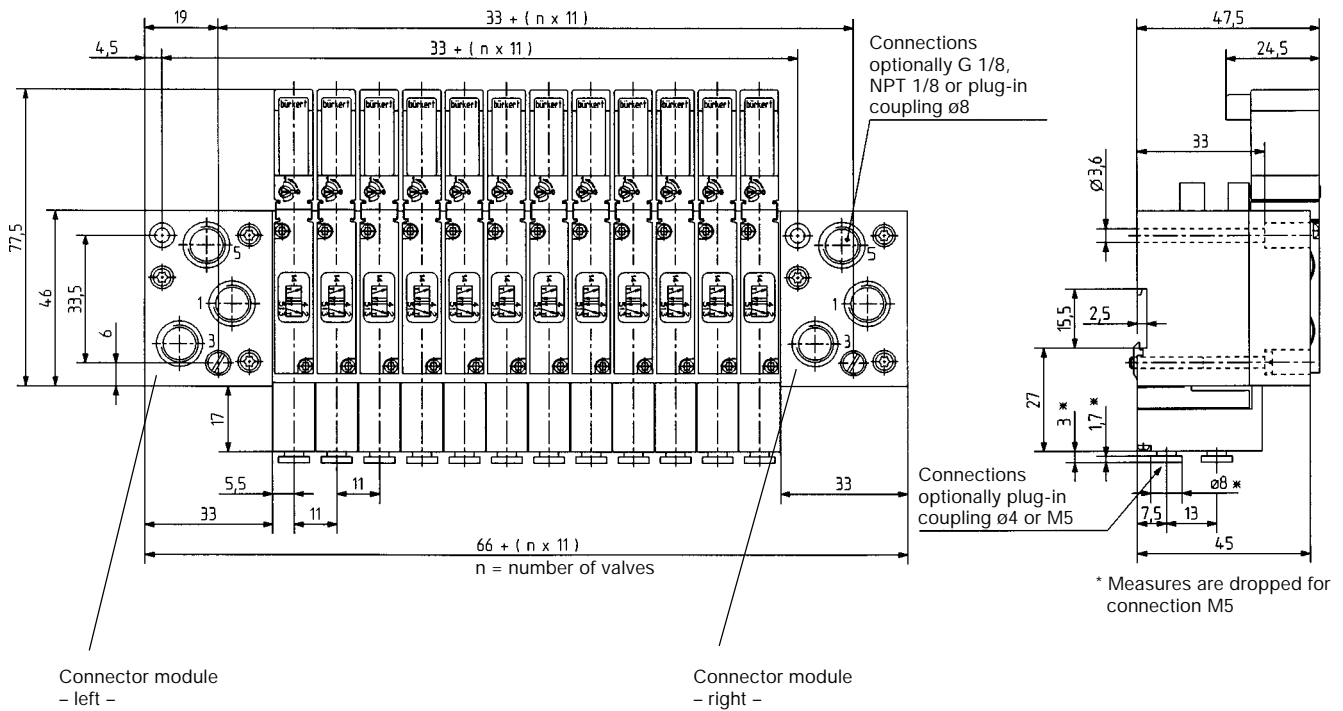

Block design with connector module on the right (1 supply port) and terminating module on the left; block assembly with rectangular plug at the back (Version 1) and in front (Version 2) possible:
rectangular plug connector necessary (see accessories)!

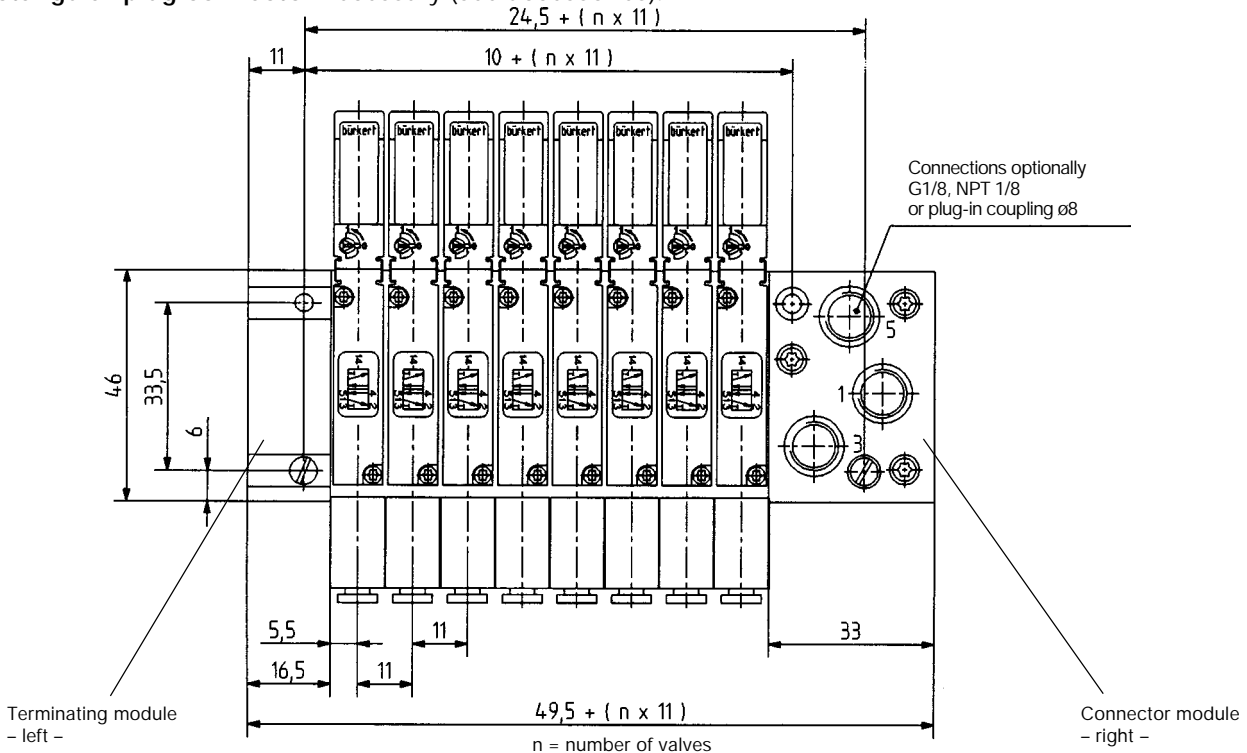

Specifications on design of a modular valve block, please see data sheet Customized Pneumatic Systems Solutions.