

Mass Flow Controller (MFC)/ Mass Flow Meter (MFM) for Gases



Type 8741 Standard

Type 8741 büS /
CANopen

Type 8741 can be combined with...

**Type 8619**

Multichannel controller

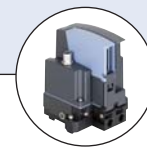
**Type 0330**2/2- or 3/2-way
Solenoid valve**Type 6013**2/2- way Solenoid
valve**Type 6606**2/2- or 3/2-
Rocker-Solenoid Valve**Type ME2X**System Control Unit (only
with 8741 büS / CANopen)

- Nominal flow ranges from 0.010 I_N/min to 80 I_N/min
- High accuracy and repeatability
- Very fast response times
- Easy device exchange through configuration memory
- Available in two versions: 8741 Standard and 8741 büS / CANopen

The mass flow controller (MFC) / meter (MFM) type 8741 for gases is available in two versions:

MFC / MFM type 8741 Standard: with Industrial Ethernet or analog interface, suitable for a wide range of applications.

MFC / MFM type 8741 büS / CANopen: suitable for the integration in existing CANopen networks, as well as in combination with the system control unit (SCU) of type ME2X for büS networks. The second option was especially developed for applications with multiple control loops. The büS network technology is based on CAN physics. Up to 32 MFC / MFM can be connected to one SCU. One functionality of the SCU is the translation of the internal, CANopen based communication to industry standards for both Industrial Ethernet and fieldbuses. The mass flow controller / meter can always be switched between büS and CANopen communication.

Type 8741 can be configured as MFM or MFC. Optional, up to four different gases can be calibrated. The thermal MEMS sensor is located directly in the gas stream and therefore reaches very fast response times. A direct-acting proportional valve as regulating unit guarantees high sensitivity. The integrated PI controller ensures outstanding control characteristics of the MFC / MFM. Type 8741 is especially designed for use in cabinets.

Technical data	
Nominal flow range (Q_{nom})	10 ml _N /min to 80 I _N /min (N ₂)
Turn-down ratio	50:1, optional 100:1
Operating medium	Neutral, non-contaminated gases, others on request
Calibration medium	Operating gas or air
Max. operating pressure	10 bar (145 psi), with MFCs the max. pressure depends on the orifice of the valve
Medium temperature	-10 °C to +70 °C (-10 °C to +60 °C with oxygen)
Ambient temperature	-10 to +50 °C (higher temperatures on request)
Measuring accuracy	±0.8% o.R. ±0.3% F.S. (after 1 min. warm up time)
Repeatability	±0.1% F.S.
Settling (MFC) / response (MFM) time (t_{95%})	< 300 ms
Materials	
Body	Aluminium or stainless steel
Housing	PC (Polycarbonate)
Seals	FKM or EPDM (dep. on gas)

Technical data	
Port connection	NPT 1/4, G 1/4, screw-in fitting or subbase, others on request
Control valve (prop. valve)	Normally closed
Valve orifice range	0.05 to 4 mm
k _{v63} value range	0.00006 to 0.32 m ³ /h
Power Supply	24V DC
Voltage tolerance	± 10%
Residual ripple	± 2%
Power consumption¹⁾	1 -3 W (as MFM), Max. 3 to 12 W (as MFC, depending on type of solenoid control valve)
Configuration memory (included in delivery)	Industrial µSIM card for ease für replacement
Protection class	IP20
Dimensions	See drawings on p. 5-8
Total weight	ca. 500 g (aluminium body)
Installation	Horizontal or vertical
Device status	RGB-LED based on NAMUR NE107

¹⁾Data refers to the typical power consumption (at 23 °C ambient temperature, nominal flow rate and 30 min control mode).

The specifications according to UL 61010-1 can differ (see instruction manual).

Technical data, continued

Elektrischer Anschluss	8741 Standard	8741 büS / CANopen
Industrial Ethernet	PROFINET, Ethernet/IP, EtherCAT via 2 x RJ45 (Switch) ¹⁾	-
Feldbus	-	büS (CAN-based Bus) / CANopen via terminal block, 4-pin
Analog	4-20 mA, 0-20 mA, 0-10 V or 0-5 V via D-Sub9 ²⁾ or terminal block 6-pin	-
Input impedance	>20 k Ω (voltage), < 300 Ω (current)	
Max. current (Voltage output)	10 mA	
Max. load (Current output)	600 Ω	

¹⁾ Supply voltage via separate terminal block

²⁾ The analog version with D-Sub9 features an additional digital input and a relay output

Nom. flow ranges of typical gases

Nom. flow ranges of typ. Gases ³⁾		
Gas	Min. Q_{Nom} [l_N/min]	Max. Q_{Nom} [l_N/min]
Argon	0.01	80
Helium	0.01	500
Carbon dioxide	0.02	40
Air	0.01	80
Methane	0.01	80
Oxygen	0.01	80
Nitrogen	0.01	80
Hydrogen	0.01	500
Propane	0.03	22

³⁾ All values refer to 1.013 bara and 0°C (Index N)

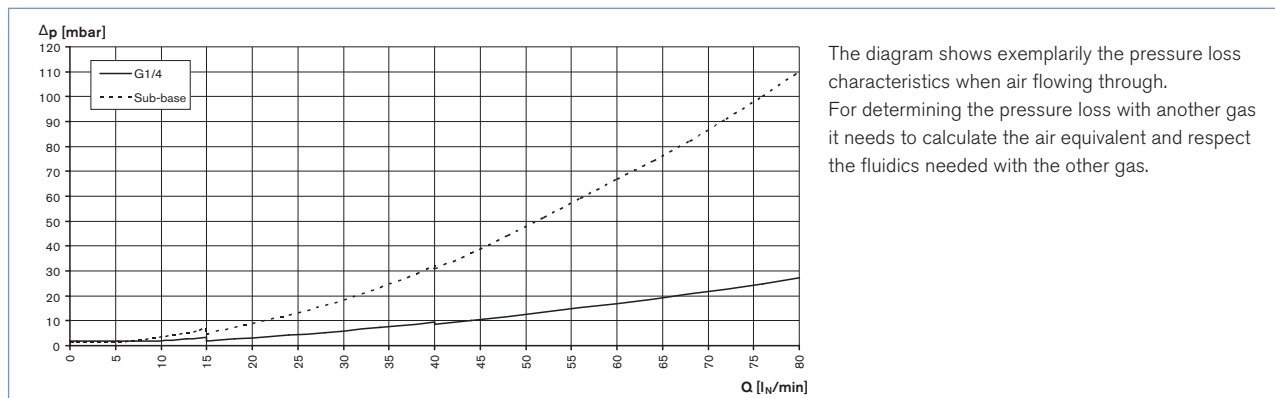
Pressure Loss Diagram of a MFM (ref. to air, with 250 μ m inlet filter)

The diagram shows exemplarily the pressure loss characteristics when air flowing through. For determining the pressure loss with another gas it needs to calculate the air equivalent and respect the fluidics needed with the other gas.

Notes Regarding the Configuration

For the proper choice of the actuator orifice within the MFC, not only the required maximum flow rate Q_{nom} , but also the pressure values *directly* before and after the MFC (p_1, p_2) at this flow rate Q_{nom} should be known. In general, these pressures are not the same as the overall inlet and outlet pressures of the whole plant, because usually there are additional flow resistors (tubing, additional shut-off valves, nozzles etc.) present both before and after the controller.

Please use the request for quotation form on p. 9 to indicate the pressures *directly* before and after the MFC. If these should be unknown or not accessible to a measurement, estimates are to be made by taking into account the approximate pressure drops over the flow resistors before and after the MFC, respectively, at a flow rate of Q_{nom} . In addition, please quote the maximum inlet pressure $p_{1,max}$ to be encountered. This data is needed to make sure the actuator is able to provide a close-tight function within all the specified modes of operation.

► **The request form on page 9 contains the relevant fluid specification. Using the experience of Bürkert engineers already in the design phase provide us with a copy of the request containing the necessary data together with your inquiry or order.**

Measuring Principle

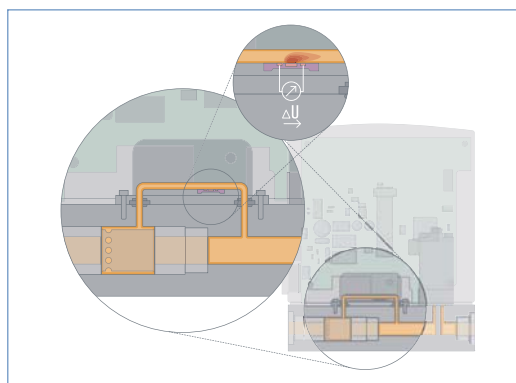

The actual flow rate is detected by a sensor. This operates according to a thermal principle which has the advantage of providing the mass flow which is independent on pressure and temperature.

A small part of the total gas stream is diverted into a small, specifically designed bypassing channel which ensures laminar flow conditions.

The sensor element is a chip immersed into the wall of this flow channel. The chip, produced in MEMS technology, contains a heating resistor and two temperature sensors (thermopiles) which are arranged symmetrically upstream and downstream of the heater. The differential voltage of the thermopiles is a measure of the mass flow rate passing the flow sensor. The calibration procedure effectuates a unique assignment of the sensor signal to the total flow rate through the device.

Pin Assignment

8741 büS / CANopen

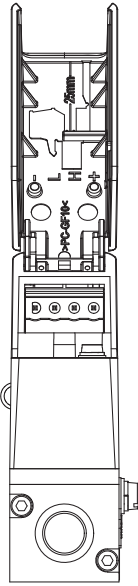

Terminal block 4-pin	Pin	Assignment
	1	GND
	2	CANL
	3	CANH
	4	+ 24 V DC
Screw M3	Assignment	
	Functional earth	

8741 Industrial Ethernet

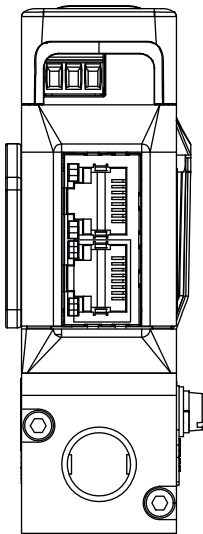

Terminal block 3-pin	Pin	Assignment
	1	FE (Functional earth)
	2	DGND
	3	+ 24 V DC
RJ45 Socket	Pin	Assignment
	1	TX +
	2	TX -
	3	RX +
	4	not connected
	5	not connected
	6	RX -
	7	not connected
	8	not connected
Body	shield	

Pin Assignment, continued

8741 Analog

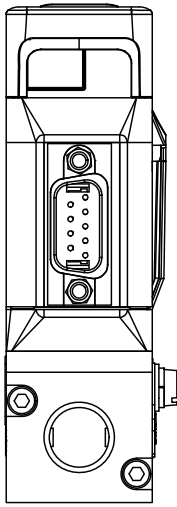

D-Sub 9-pin, plug	Pin	Assignment
	1	Digital input
	2	GND
	3	+ 24 V DC
	4	Relay - Opener
	5	Relay - Reference contact
	6	Set value input +
	7	Set value input GND
	8	Actual value output
	9	Actual value output GND
Body	shield	

8741 Analog

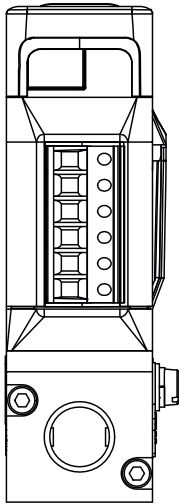

Terminal block 6-pin	Pin	Assignment
	1	+ 24 V DC
	2	GND
	3	Set value input +
	4	Set value input GND
	5	Actual value output +
	6	Actual value output GND

Dimensions [mm] 8741 büS / CANopen

Standard version: 8741 büS / CANopen

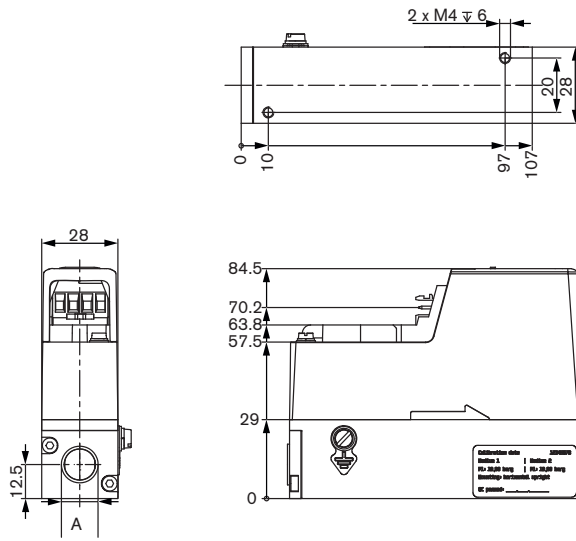

A: G1/4 or NPT1/4, depth 12 mm

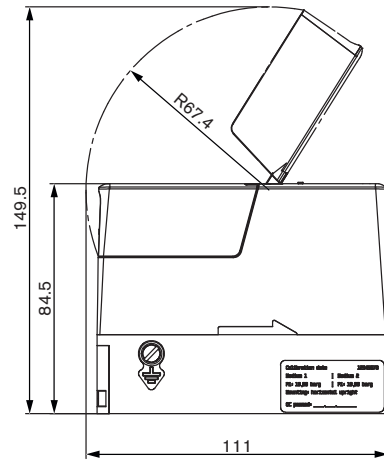
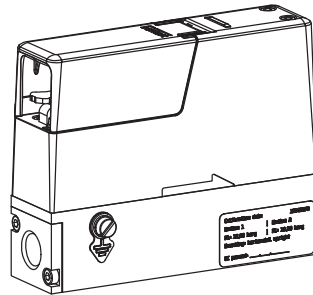

Sub base version: 8741 büS / CANopen

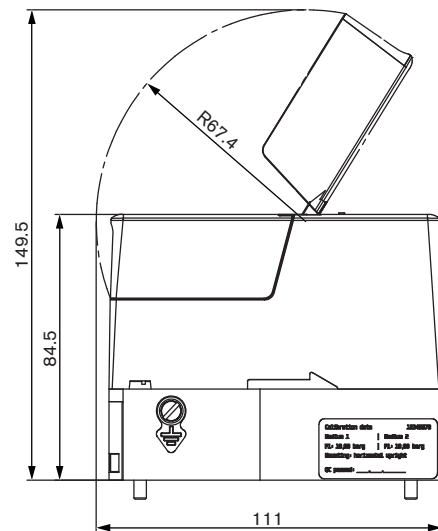
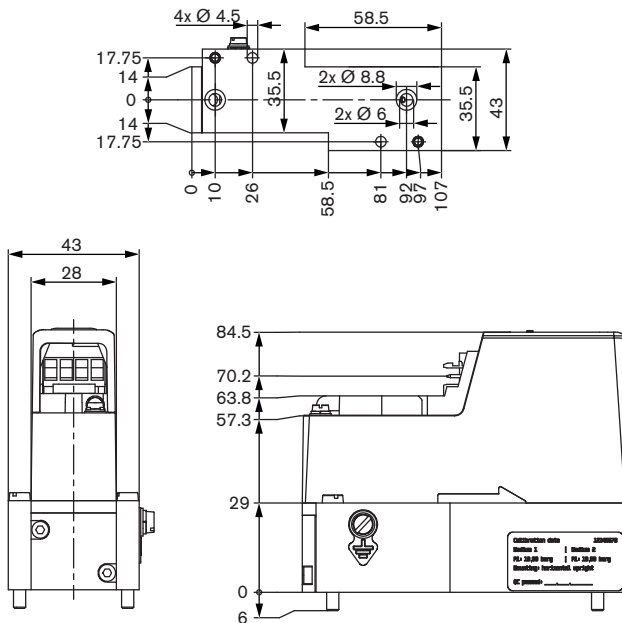

Dimensions [mm] 8741 büS / CANopen, continued

Version with external valve: 8741 büS / CANopen

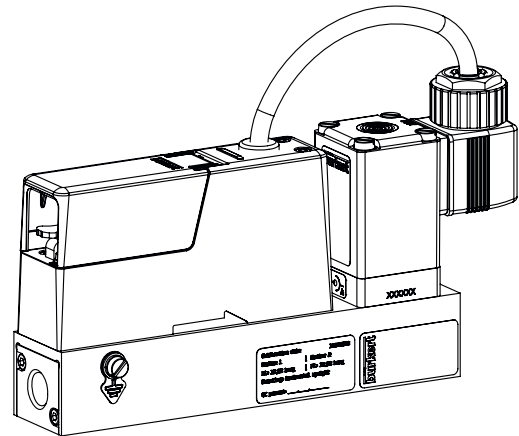
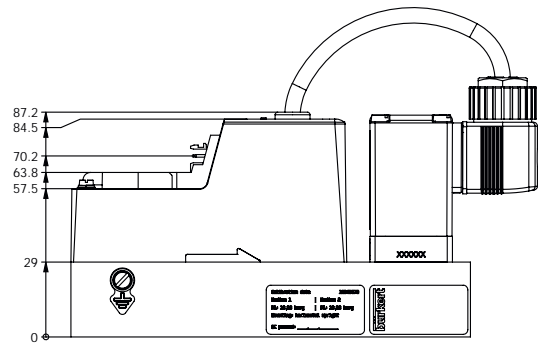
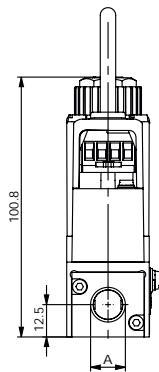
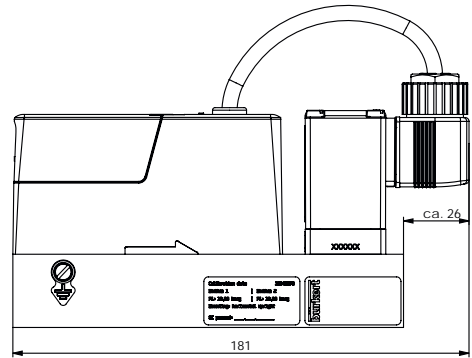
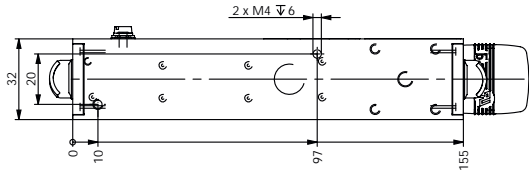

Dimensions [mm] 8741 Standard

Standard version: 8741 standard

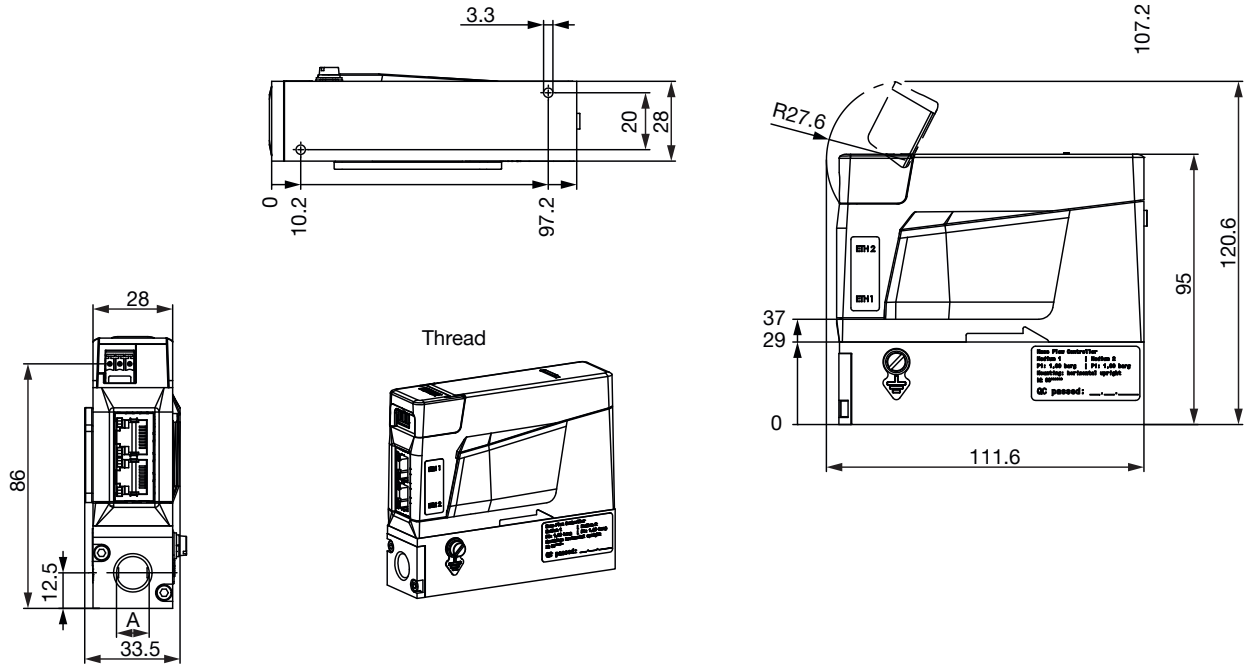

Sub-base version: 8741 standard

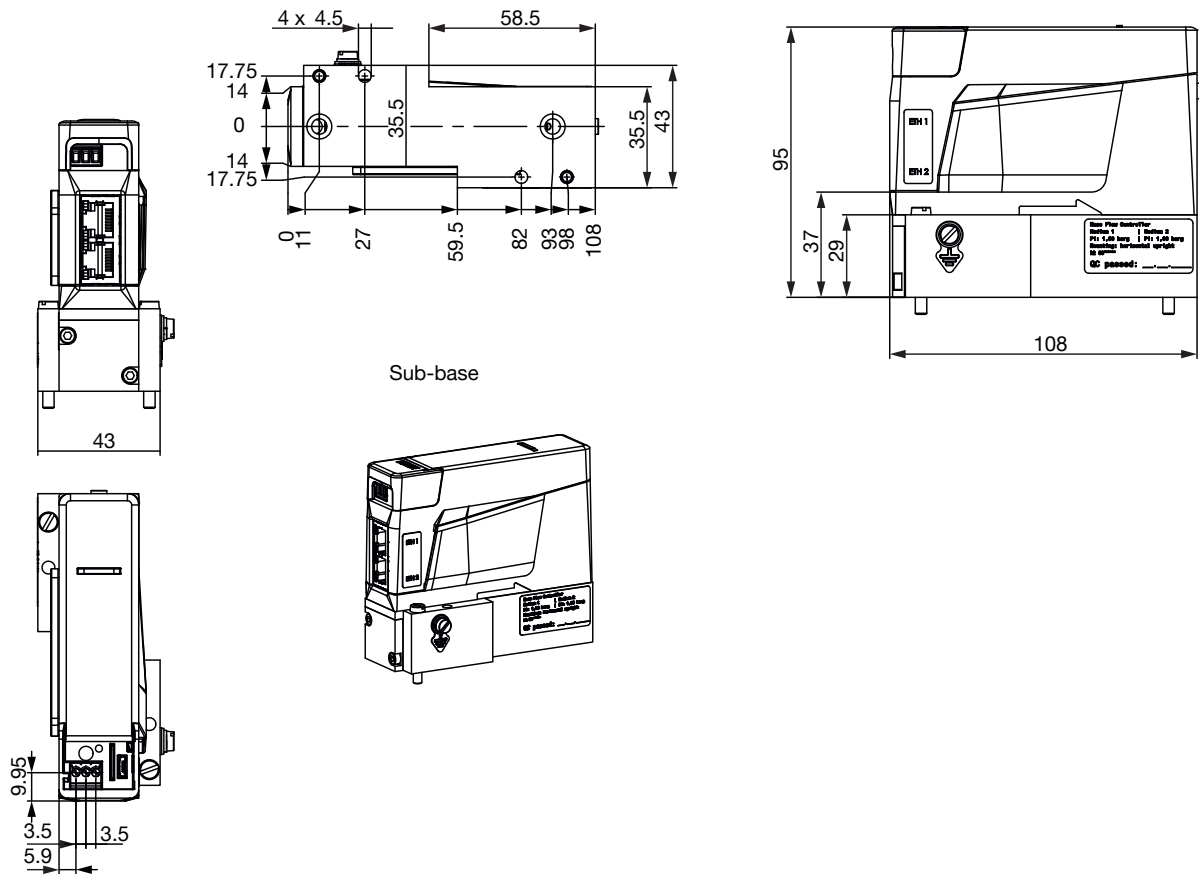

Dimensions [mm] 8741 Standard, continued

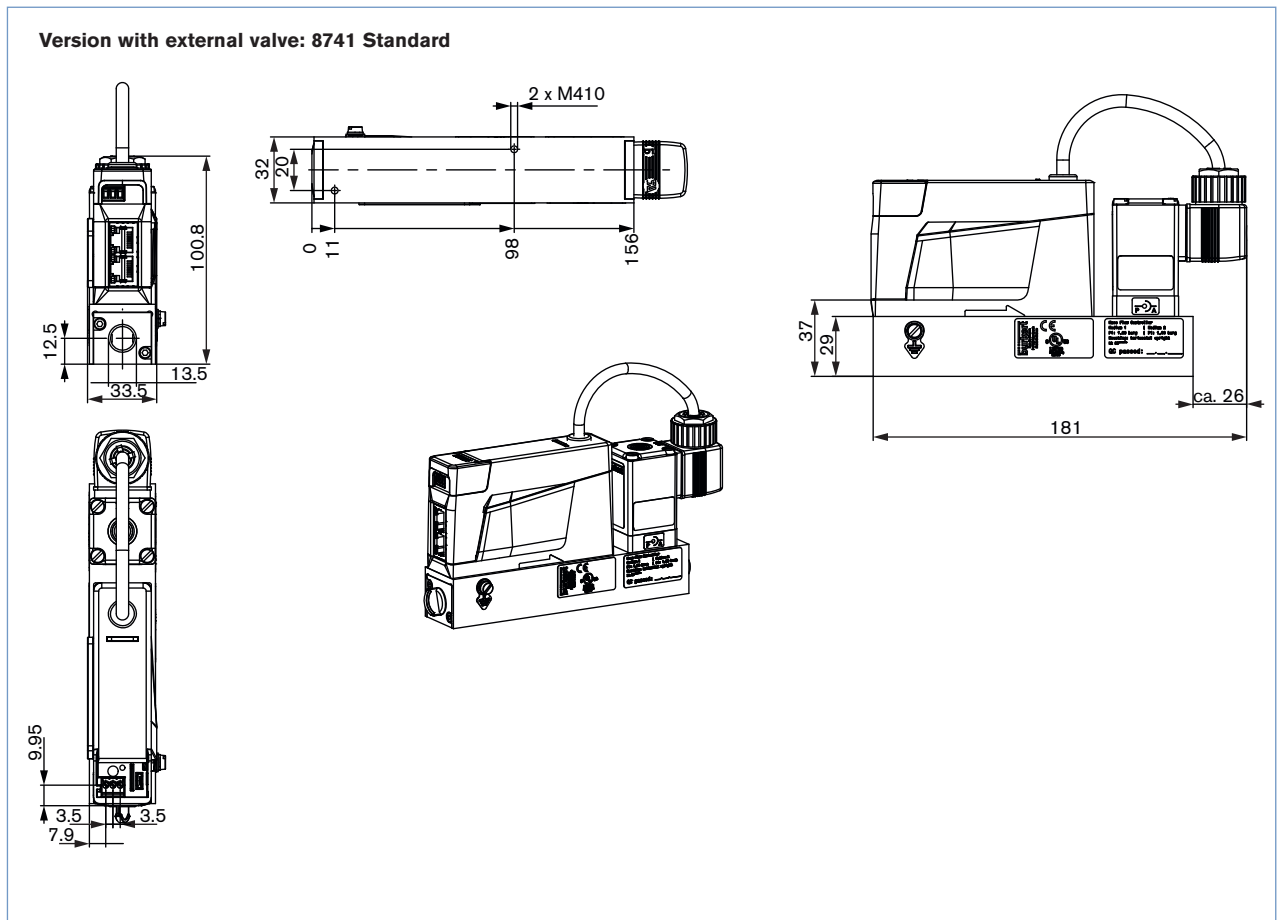

Ordering chart for accessories

Article	Item No.
Terminal block 4-pin (for 8741 büS / CANopen; included in delivery)	565 876
Terminal block 4-pin with integrated 120 Ohm resistance for büS-ending (for 8741 büS / CANopen)	566 066
Terminal block 6-pin (for 8741 Standard; included in delivery off the corresponding analogue version)	on request
büS-Stick Set 1 (inkl. cable (M12 and Micro-USB) Stick with integrated terminating resistor, power supply and software)	772 426
büS-Stick Set 2 (inkl. cable (M12 and Micro-USB) Stick with integrated terminating resistor)	772 551
µSIM-Karte (included in delivery of MFC)	on request
LabVIEW device driver	on request
Device description files for CANopen (EDS), PROFINET (GSDML), Ethernet/IP (EDS), EtherCAT (ESI)	Download from www.burkert.com
Software Bürkert Communicator	Download from www.burkert.com

To connect the MFC / MFM with the „Bürkert Communicator“ software tool, you need a büS-stick.

The büS-Stick sets contain the necessary accessories.

For type 8741 büS / CANopen, the connection is made directly via the 4-pin terminal block (büS-Stick Set 1 contains the necessary accessories).

For type 8741 Standard the connection is made via the micro-USB socket on the device (büS-Stick Set 2 contains the necessary accessories).

Software Bürkert Communicator

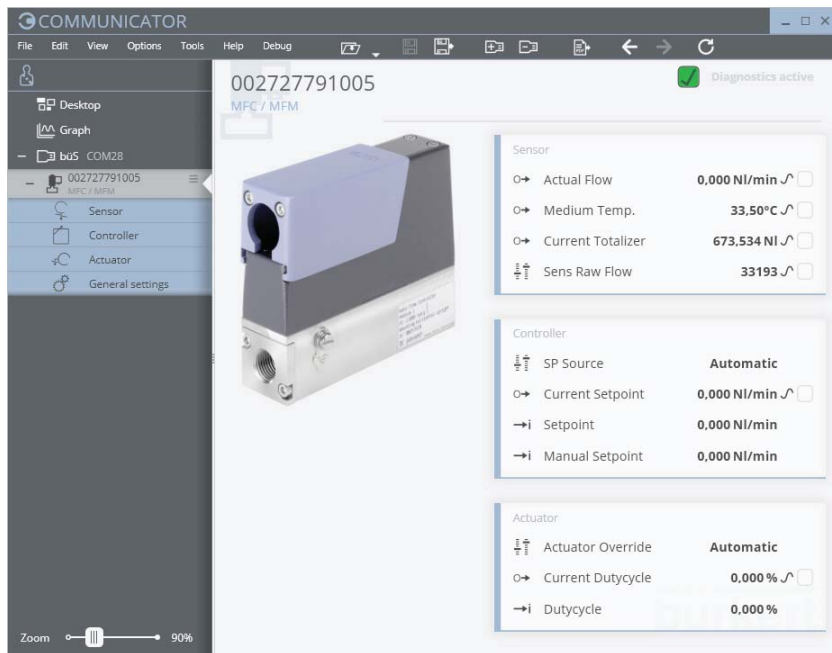

To install the software, click on the download button.

[Download](#)

Part of Bürkert's new EDIP program (Efficient Device Integration Platform) is the Bürkert Communicator. This software can be run under MS-Windows and it is available on Bürkert's website for free. The Bürkert Communicator allows convenient system configuration and parameterisation of all connected field devices. An accessory part, the büS stick – please see ordering chart for accessories – serves as the interface between computer and process instruments. It transfers "USB data" to "CAN data". The Communicator allows:

- Diagnosis - Parameterization - Registration and storage of process data. The Communicator allows:
- Diagnosis
- Parameterization
- Registration and storage of process data
- Data logging
- To watch graph of process
- To update firmware of the büS device connected
- To program system controls by User-f(x) – e.g. gas blending
- guided re-calibration
- ...

Note

You can fill out the fields directly in the PDF file before printing out the form.

MFC/MFM-applications - Request for quotation

▶ Please complete and send to your nearest Bürkert sales centre

Company	Contact person
Customer No	Department
Address	Tel./Fax
Postcode/Town	E-mail

MFC-Application MFM-Application Quantity Required delivery date

Mediumsangaben

Type of gas (or gas proportion in mixtures)

Density kg/m³⁸⁾

Gas temperature [°C or °F] °C °F

Moisture content g/m³

Abrasive components/solid particles no yes, as follows:

Fluidic data

Flow range Q_{nom} Min. l_N/min⁸⁾ l_S/min (slpm)⁹⁾
 Max. m_N³/h⁸⁾ kg/h
 cm_N³/min⁸⁾ cm_S³/min (sccm)⁹⁾
 l_N/h⁸⁾ l_S/h⁹⁾

Inlet pressure at Q_{nom} ¹⁰⁾ $p_1 =$ bar(g) ■

Outlet pressure at Q_{nom} $p_2 =$ bar(g) ■

Max. inlet pressure P_{1max} bar(g) ■

MFC/MFM port connection

without screw-in fitting

1/4" G-thread (DIN ISO 228/1)

1/4" NPT-thread (ANSI B1.2)

with screw-in fitting (acc. to specification for pipeline)

mm Pipeline (external Ø)

inch Pipeline (external Ø)

Flange version

Installation

horizontal

vertical, flow upward vertical, flow down

Ambient temperature °C

Material data

Body base Aluminium Stainless steel

Seal FKM EPDM

Electrical data

Signale für Sollwerteingang/Istwertausgang

8741 büS / CANopen: CANopen or büS

8741 Standard: PROFINET Ethernet/IP EtherCAT

4-20 mA 0-20 mA 0-10 V 0-5 V terminal block-version (Default: D-Sub9)

■ Please quote all pressure values as overpressures with respect to atmospheric pressure bar(ü)

⁸⁾ at: 1,013 bar(a) and 0 °C

⁹⁾ at: 1.013 bar (a) and 20 °C

¹⁰⁾ matches with calibration pressure