



System Control Unit (SCU)

- Fieldbus coupler for Industrial Ethernet and Fieldbus standards
- Up to 128 input and 128 output variables can be assigned
- Easy integration in the process control system ensured through system specific device description files
- Optional: Expandable with I/O modules
- Optional: Graphical programming for automation of sub-systems

powered by
EDIP

Type ME2X can be combined with ...

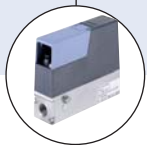

Type 874x



Type 8905

The System Control Unit (SCU) of Type ME2X is the central control unit for Bürkert devices (valves, sensors, mass flow controller or displays), which are based on EDIP ("Efficient Device Integration Platform"). The basic version of Type ME2X consists of power-in and power-out modules of Type ME29 and a fieldbus coupler of Type ME23. This fieldbus coupler transmits the internal CANopen based communication of the Bürkert field devices to industrial standards for Industrial Ethernet and fieldbus.

Additionally I/O modules from Type ME24 for analog and digital signals can be used to expand the system. Through these standard signals other field devices without a fieldbus interface can be integrated. (For e.g. analog sensors, valves etc.)

With the help of the graphical programming sub-systems can be automated specifically to the customer's needs. (For e.g. controlled mixing of gases, error monitoring through switching commands, timer switches etc.)

Technical data	
Materials of housing	PC (Polycarbonate)
Gateway functionality (Integrated switch for Industrial Ethernet)	PROFINET Ethernet/IP Modbus/TCP Profibus-DP
Input-/ Output signal	via module ME24 2AI / 2DI 2AO / 2DO 4DO
Configuration storage	Micro SD Card (for storing device parameters and configuration, datalogging and easy replacement of a module)
Operating voltage	18 to 35V DC
Light diodes Power consumption Housing (external)	2W RGB-LED based on NAMUR NE107
Ambient temperature	0 to 50°C
Protection class ME21 (Display), ME23 (Gateway) ME24 (I/O Modul), ME29 (entry-exit module), BEF1 (Backplane)	IP20 IP65
Installation	Horizontal or vertical on top hat rail EN 50022

ME24 I/O Modules (optional) Electrical properties of inputs and outputs

Supply voltage: 20...30 V over the Backplane BEF1

UL devices: Power supply unit limited to Class 2

Power consumption: < 3 W

If the outputs are supplied via bÜS, the total current is internally limited to 2 A; max. 48 W

Feature	2AO / 2DO / f(x) Modul		4DO / f(x) Modul	2AI / 2DI Modul	
	Analog output; AO	Digital output; DO	Digital output (PWM); DO	Analog input; AI	Digital input; DI
Electrical signal	Current output	Transistor output	Transistor output: Open-Drain-output	Current input or voltage input	Voltage input
Operating mode	4...20 mA	On-Off Threshold value PWM PFM	On-Off Threshold value PWM PFM	4...20 mA 0...20 mA 0...10 V 0...5 V 0...2 V	0...35V DC
Current consumption	-	0.7A per channel / 1A per module* *Load supplied via the SCU	0.7A per channel / 1.8A per module* *Load supplied via the SCU	-	-
Input impedance	-	-	-	110 Ω at cur- rent input 120 kΩ at vol- tage input	ca. 3...5 kΩ at voltage of 5...35 V
Switching threshold	-	-	-	-	VON = 5...35 V VOFF < 2 V DC
Loop impedance (max.) at current output 22mA	1350 Ω at 35 V DC 850 Ω at 24 V DC 300 Ω at 12 V DC	-	-	-	-
Galvanic isolation (between the channels and the power supply of the module electronics)	Yes	Yes	-	Yes	Yes
Diagnosis	Inverse-polarity protection	Yes	-	Yes	Yes
	Overload detection	-	Yes	-	-
	Detection of open loop	Yes	-	-	Yes at voltage input
Resolution	6μA	-	-	12 bit	-
Sampling time	-	-	-	100ms	-
Measurement frequency	-	Max. 2500 Hz	-	-	0.5...2500 Hz
Clock frequency	-	-	20 kHz	-	-

EDIP – Efficient Device Integration Platform

EDIP is the new Bürkert device platform which will in the future standardise the operation, communication and interfaces of many process devices (e.g. Sensors, Mass Flow Controller). Thanks to EDIP the devices can be intelligently networked and operated with with the consistent Software, the Bürkert Communicator. The backbone and connecting link of EDIP is the digital interface which complies with the CANopen standard and is always downwards compatible to it. EDIP offers following advantages to the user:

- Interoperability - guaranteed by the uniform interface
- Comfortable operating and display concept
- Fast start-up and easy commissioning
- Modularity – allows adjustment of the devices to individual customer requirements
- Easy transfer and backup of device settings

System Connect with Type ME2X

Example of a possible SCU-configuration. Further modules can be added to expand the system.

No.	Module	Type
1	Backplane left	BEF1
2	Backplane (for Type ME23, ME24, ME25)	BEF1
3	Backplane right	BEF1
4	büS input module (M12) ¹⁾	ME29
5	Gateway module	ME23
6	I/O module (2AI/2DI)	ME24
7	I/O module (2AO/2DO)	ME24
8	I/O module (4DO)	ME24
9	büS output module (M12) ¹⁾	ME29

¹⁾ also available with terminal blocks

Pin assignment

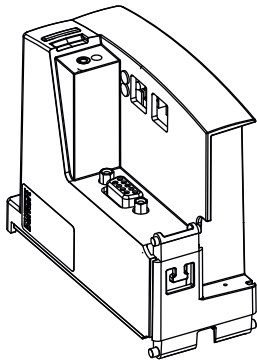
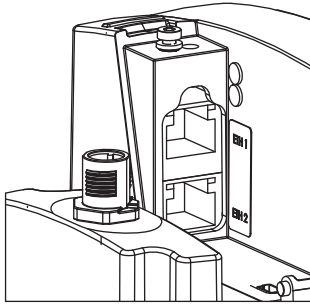
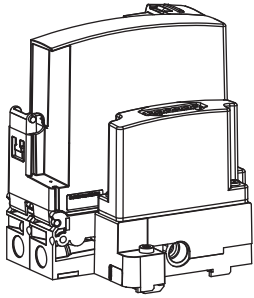
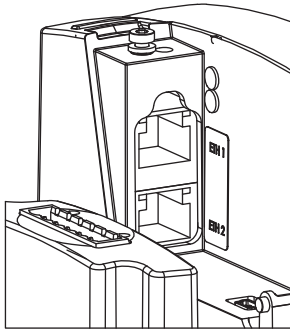

Terminal block 6-pin male (Power input)	Pin	Assignment
	1	DGND
	2	CAN_L
	3	SHIELD
	4	CAN_H
	5	V+ (only input)
	6	FE (opt.)
Terminal block 6-pin female (Power output)	Pin	Assignment
	1	DGND
	2	CAN_L
	3	SHIELD
	4	CAN_H
	5	V+ (only output)
	6	FE (opt.)
M12, 5-pin, male (Power input)	Pin	Assignment
	1	SHIELD
	2	V+ (only input)
	3	DGND
	4	CAN_H
	5	CAN_L
M12, 5-pin, female (Power output)	Pin	Assignment
	1	SHIELD
	2	V+ (only output)
	3	DGND
	4	CAN_H
	5	CAN_L
D-SUB 9-pin, female	Pin	Assignment
	1	SHIELD
	2	N.C.
	3	RxD/TxD - P (B-Line)
	4	CNTR-P
	5	GND
	6	+5 V (only for termination resistor)
	7	N.C.
	8	RxD/TxD - N (A-Line)
	9	N.C.

Hinweis:

1) Both, the bÜS input and output modules (ME29) include an integrated 120 Ohm resistor for bus termination. On demand, the resistors can be switched on or off via a DIP switch.

2) CANopen requires two termination resistors: one at the beginning and one at the end of the network. An indicator of the correct bus termination is the resistance between CAN_H and CAN_L when the power supply is disconnected; this should be about 60 Ohm.

Pin assignment and wiring

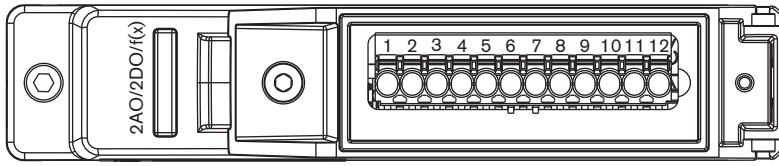

2AO/DO/f(x)		
Pin	Pin assignment	External circuit
1	+	20 - 30 V / 2 A max. OUTPUT no galvanic isolation
2	-	20 - 30 V / 2 A max. OUTPUT no galvanic isolation
3	AO1+	+ (4 - 20 mA) output galvanically isolated
4	AO1-	- (4 - 20 mA) output galvanically isolated
5	FE	Shielding
6	AO2+	+ (4 - 20 mA) output galvanically isolated
7	AO2-	- (4 - 20 mA) output galvanically isolated
8	DO1+	+ NPN galvanically isolated
9	DO1-	- NPN galvanically isolated
10	FE	Shielding
11	DO2+	+ NPN galvanically isolated
12	DO2-	- NPN galvanically isolated

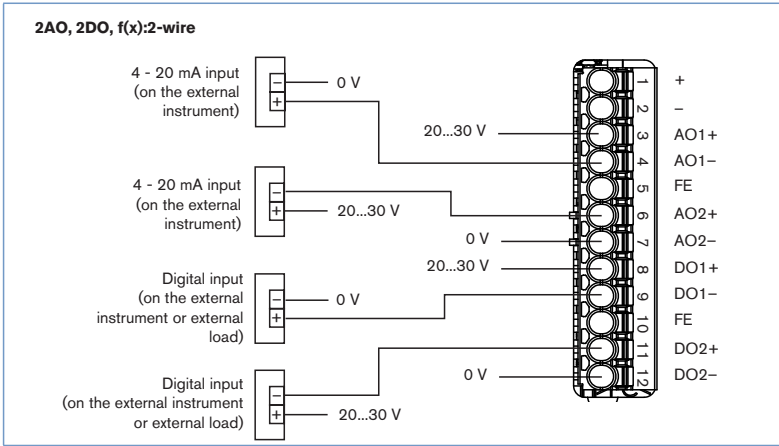

External circuit 2AO, 2DO, f(x), 2-wire

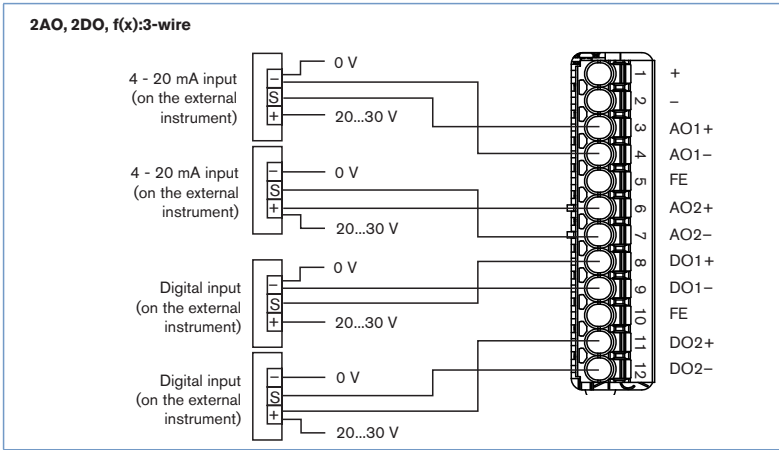

External circuit 2AO, 2DO, f(x), 3-wire

Pin Assignment and wiring, continued

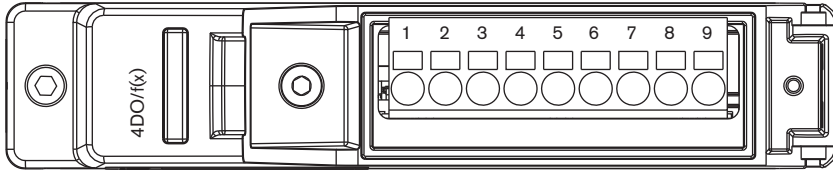

4DO/f(x)		
Pin	Pin assignment	External circuit
1	+	20 - 30 V / 2 A max. total current no galvanic isolation
2	DO1-	Open Drain
3	+	20 - 30 V / 2 A max. total current no galvanic isolation
4	DO2-	Open Drain
5	+	20 - 30 V / 2 A max. total current no galvanic isolation
6	DO3-	Open Drain
7	+	20 - 30 V / 2 A max. total current no galvanic isolation
8	DO4-	Open Drain
9	FE	Shielding

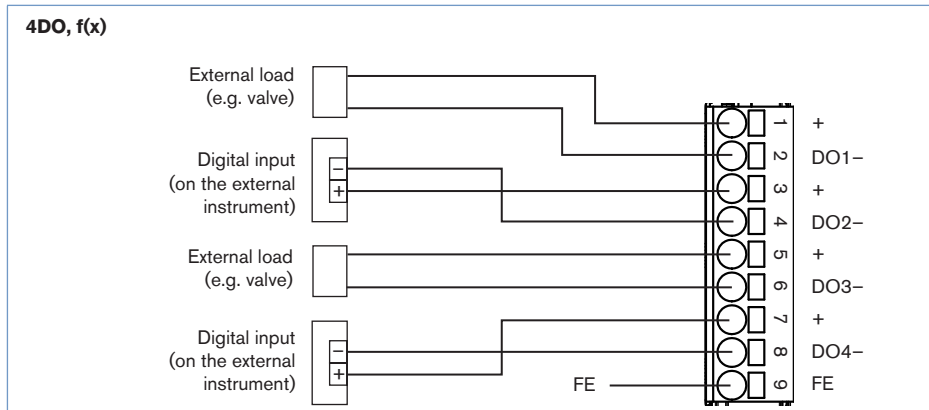

External circuit 4DO PWM 20 kHz

Pin Assignment and wiring, continued

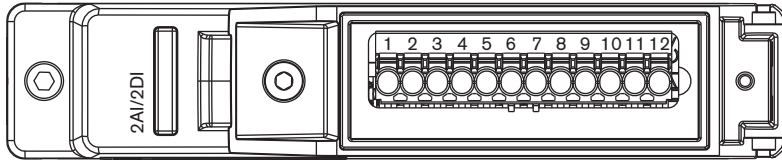

2AI/2DI		
Pin	Pin assignment	External circuit
1	+	20 - 30 V / 2 A max. OUTPUT no galvanic isolation
2	-	20 - 30 V / 2 A max. OUTPUT no galvanic isolation
3	AI1+	+ (0/4 - 20 mA, 0 - 2/5/10 V) Input galvanically isolated
4	AI1-	- (0/4 - 20 mA, 0 - 2/5/10 V) Input galvanically isolated"
5	FE	Shielding
6	AI2+	+ (0/4 - 20 mA, 0 - 2/5/10 V) Input galvanically isolated
7	AI2-	(0/4 - 20 mA, 0 - 2/5/10 V) Input galvanically isolated
8	DI1+	+ (ON: 5 - 35 V, OFF: >2 V) Input galvanically isolated
9	DI1-	- (ON: 5 - 35 V, OFF: >2 V) Input galvanically isolated
10	FE	Shielding
11	DI2+	+ (ON: 5 - 35 V, OFF: >2 V) Input galvanically isolated
12	DI2-	- (ON: 5 - 35 V; OFF: >2 V) Input galvanically isolated

2AI,2DI: 2-wire

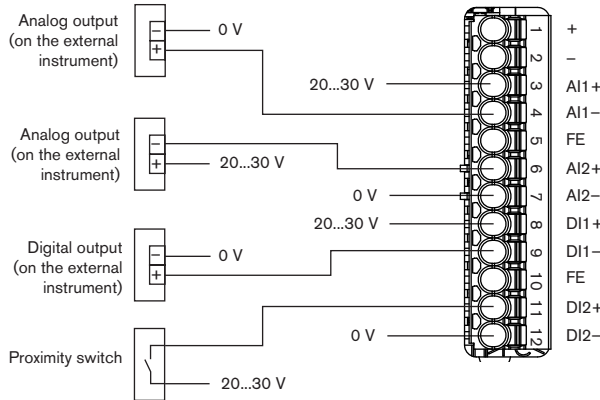

External configuration 2AI, 2DI, 2-wire

2AI,2DI: 3-wire

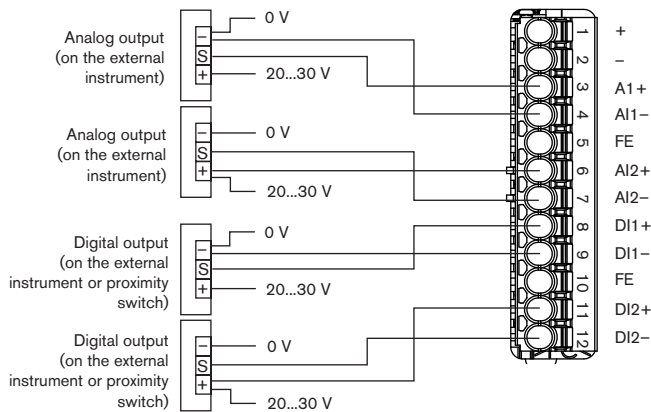

External configuration 2AI, 2DI, 3-wire

Software Bürkert Communicator

The Bürkert Communicator is the most important software component of the 'Efficient Device Integration Platform' (EDIP). Various features of this universal tool simplify the configuration and parameterization of devices equipped with a digital CANopen based interface. With this tool the user has a complete overview of cyclic process values as well as acyclic diagnosis data. In the near future, an integral part of the Communicator will be a graphical programming environment which will help in creating decentralized sub-system control functions. The connection to the PC is established with a USB-CAN adapter.

The communicator allows:

- Configuration, parameterisation and diagnosis of EDIP devices / networks
- Easy and comfortable mapping of cyclic values
- Graphical display of process values
- Firmware update for the connected EDIP devices
- Backup and restoring of device configurations
- Recalibration routine controlled

To install the software, click on the download button.

[Download](#)

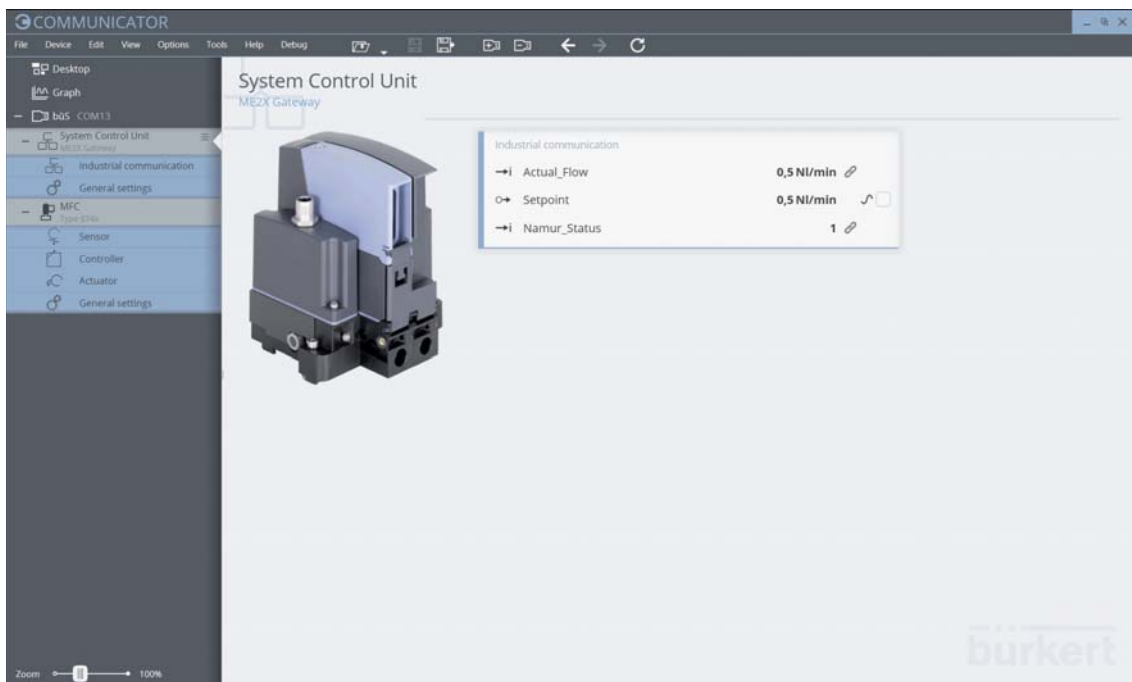

Networking

Example of a network with SCU and MFCs

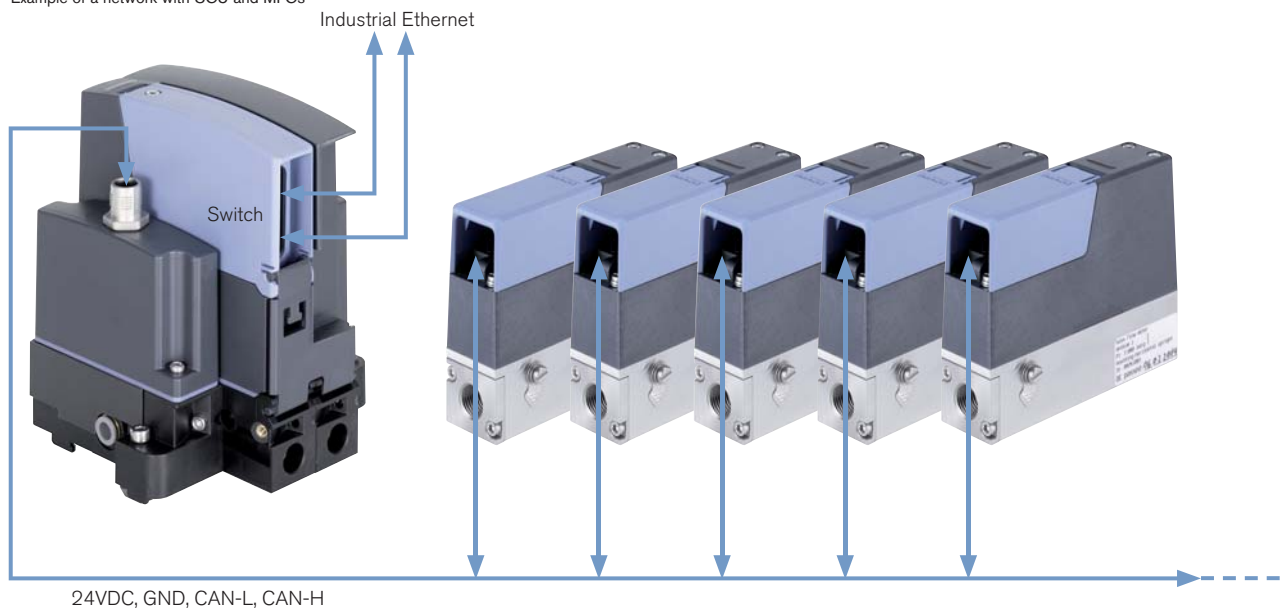

Dimensions [mm]

Possible version with M12 for büS connection*

*versions with terminal block are also available

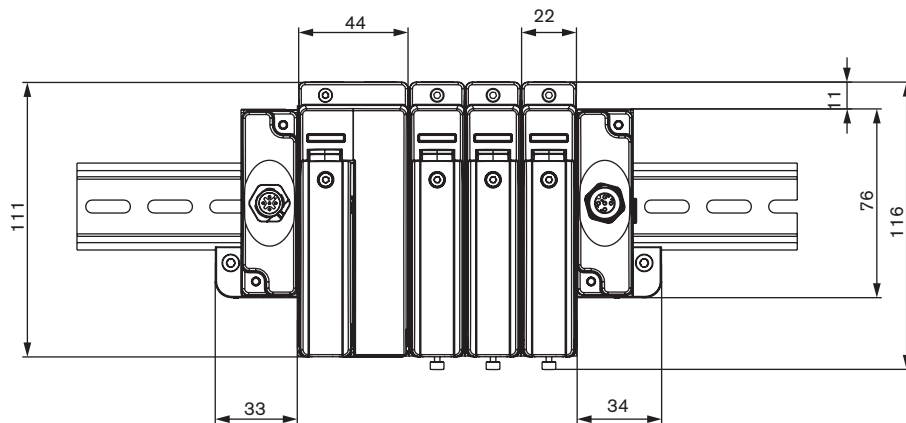
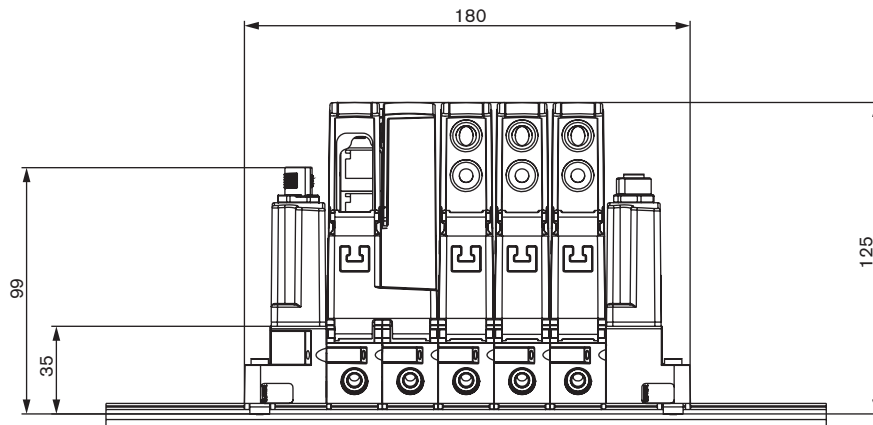
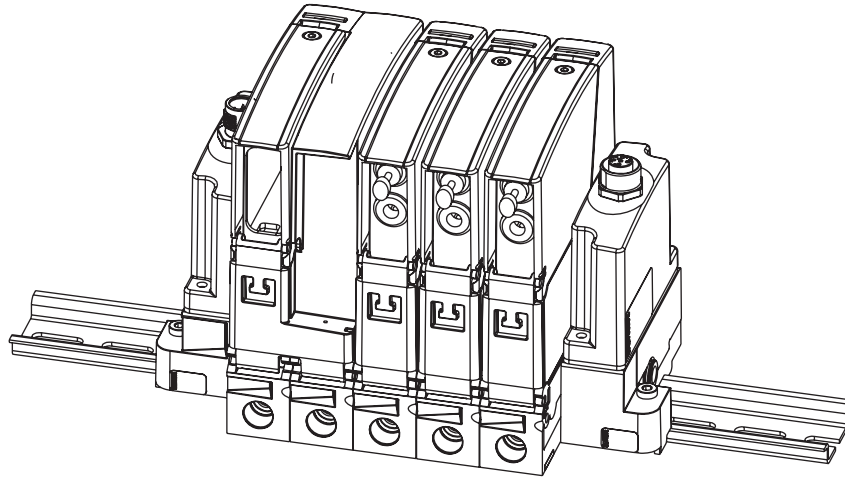

Ordering chart for accessories

Article	Item No.
büS cable extension M12 0.1m	772 492
büS cable extension M12 0.2m	772 402
büS cable extension M12 0.5m	772 403
büS cable extension M12 1m	772 404
büS cable extension M12 3m	772 405
Connector M12, female, straight ¹⁾	772 416
Connector M12, male, straight ¹⁾	772 417
Connector M12, female, angled ¹⁾	772 418
Connector M12, male, angled ¹⁾	772 419
Y distributor	772 420
Y distributor for connecting two separately powered segments of a büS network	772 421
Termination resistor 120 Ohm M12 male	772 424
Termination resistor 120 Ohm M12 female	772 425
Power supply Type 1573 for rail mounting, 100-240 V AC/ 24V DC, 1.25A, NEC Class 2 (UL 1310)	772 438
Power supply Type 1573 for rail mounting, 100-240 V AC/ 24V DC, 1A, NEC Class 2 (UL 1310)	772 361
Power supply Type 1573 for rail mounting, 100-240 V AC/ 24V DC, 2A, NEC Class 2 (UL 1310)	772 362
Power supply Type 1573 for rail mounting, 100-240 V AC/ 24V DC, 4A	772 363
Micro SD Card	on request
büS-Stick Set 1 (incl. cable (M12)), stick with integrated termination resistor, power supply and software	772 426
büS-Stick Set 2 (incl. cable (M12)), stick with integrated termination resistor	772 551
Terminal block 6-pin male (connector to büS input module)	on request
Terminal block 6-pin female (connector to büS output module)	on request
License for graphical programming (only when > 10 blocks are required)	567 713
Software Bürkert Communicator	http://www.burkert.com/en/type/8920

¹⁾ Due to lack of space, the M12 single connectors may not be suitable for their simultaneous use on the same side of the Y-distributor. Please use the available ready-made assembled cable in this case.