



INSERTION fitting for flow or analytical measurement

- Universal fitting for INSERTION measuring device in pure, aggressive or polluted liquids
- Large range of process connections: DN06 to DN400 in PVC, PP, PVDF, PE, stainless steel, brass
- Electronics available also with extended functions
 - Indication, Monitoring, Transmitting
 - On/Off control, Batch control

Type S020 can be combined with...



Type 8020

Paddle wheel flowmeter



Type 8026

Paddle wheel flowmeter



Type 8025

Paddle wheel flowmeter



Type 8045/8041

Electromagnetic flowmeter G2ⁿ connection



Type 8045/8041

Electromagnetic flowmeter clamp connection

The fitting can be used to connect any INSERTION device for a measurement in the pipe. i.e. sensors, indicators and controllers for flow, pH, oxidation reduction potential (O.R.P) and conductivity measurement. The fitting is available for flowmeter having a G2ⁿ or a clamp connection.

General data

Pipe diameter

G2 ⁿ flowmeter connection	DN06 to DN400 ¹⁾
Clamp flowmeter connection	DN32 to DN100

Fitting process connections

Metal	Internal or external thread, weld ends, clamp or flange
Plastic	True union, spigot or external thread

Materials

G2 ⁿ flowmeter connection	FKM or EPDM
Seal	
Body & adapter	
Clamp flowmeter connection	Brass (CuZn39Pb2) & stainless steel (316L -1.4404), all in stainless steel (316L -1.4404) or all in PVC, PP, PVDF, PE Stainless steel 316L

Surface finish

Clamp flowmeter connection	Ra < 0.8 μm
----------------------------	-------------

Medium data

Medium temperature

0...+50°C (32...122°F) for fitting in PVC
0...+80°C (32...176°F) for fitting in PP
-15...+100°C (5...212°F) for fitting in PVDF
-15...+160°C (5...320°F) for fitting in stainless steel or brass

Temperature limits may depend on the inserted device. Refer to the relevant data sheet or instruction manual and the pressure/temperature diagram of the fluid on next page. If the temperature ranges given for the adapter and the inserted device are different, use the most restrictive range

Medium pressure (max.)

Metal	PN16 (232.16 PSI)
Plastic	PN10 (145.1 PSI)

Pressure limits may depend on the inserted device. Refer to the relevant data sheet or instruction manual and the pressure/temperature diagram of the fluid on next page. If the pressure ranges given for the adapter and the inserted device are different, use the most restrictive range

Environment

Ambient temperature

Temperature limits may depend on the inserted device. Refer to the relevant data sheet or instruction manual for more details

¹⁾ Combination between fitting and measuring device is sometimes restricted to some DN (see diagram: combining the S020 with a measuring device on next page).

Approvals

Approval/Certificate on request

Inspection certificate 3.1 (acc. to EN-ISO 10204); Test report 2.2 (acc. to EN-ISO 10204); Certification of Conformity for the surface Quality (DIN4762-DIN4768-ISO/4287/1); 3 points Flow calibration certificate; FDA (with EPDM seal) - stainless steel fitting only

Pressure/temperature diagram

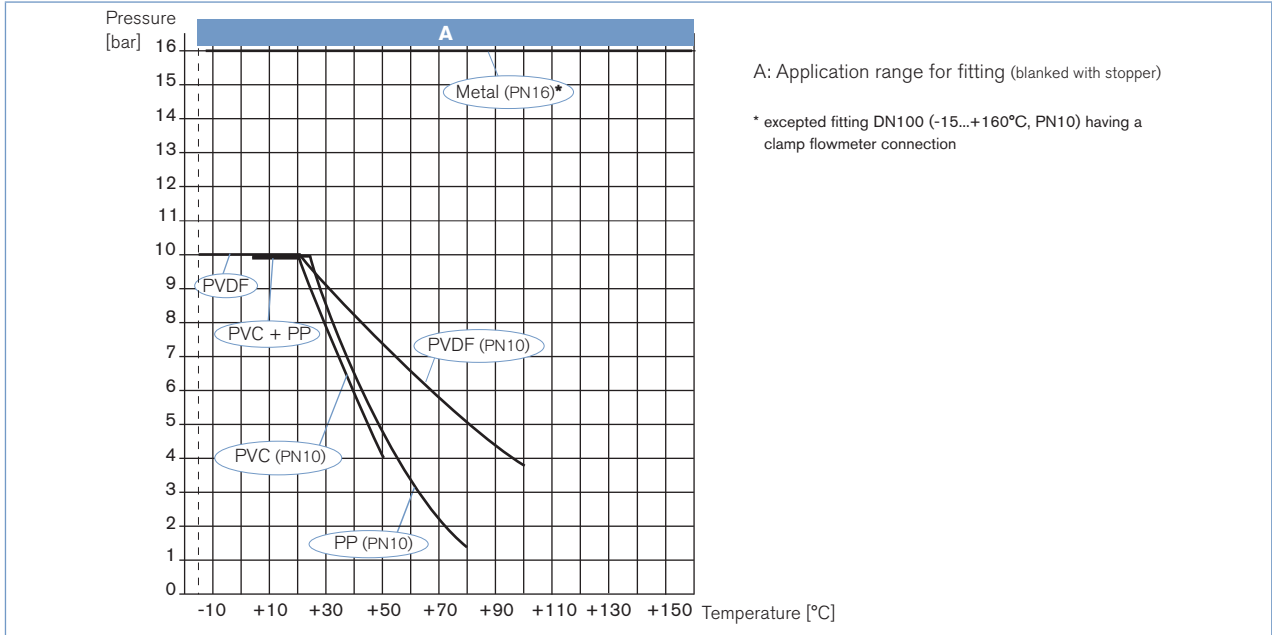

Combining the S020 with a measuring device for flow rate, pH or O.R.P., conductivity measurement

	DN06	DN32	DN50	DN65	DN100	DN200	DN350	DN400
T-fitting with G2" flowmeter connection	[Available]							
T-fitting or welding socket with Clamp flowmeter connection	[Available]							
Welding socket	[Available]							
Fusion spigot	[Available]							
Screw-on	For flow measurement							
Saddle	For flow measurement							
Flow rate measurement	DN06	DN15	DN20*	DN32	DN50	DN100	DN200	DN400
8020 - 8025 - 8026 - 8041 - 8045 with G2" connection	only 8041/8045		Short sensor version		Short or long version**		Long sensor version	
8041 - 8045 with clamp connection	[Available]							
pH or O.R.P. measurement 8200/8203	***							
Conductivity measurement 8220 - 8223 - 8228	***							

* Except fittings with external threads acc. to SMS 1145, weld ends acc. to SMS 3008, BS 4825-1/ASME BPE/DIN 11866 series C or DIN 11850 series 2/DIN 11866 series A/ DIN EN 10357 series A, Clamp acc. to SMS 3017, BS 4825-3/ASME BPE, DIN 32676 series A for 8020, 8025, 8026

** See Note on each fitting dimensions diagram

*** Only use plastic fitting in analytical version with true union acc. to DIN 8063 (PVC), to DIN 16962 (PP) or to ISO 10931 (PVDF)

For further details about the various combination possibilities (measuring device and fitting), please consult the measuring device related data sheet.

Installation

Flow measurement:

Minimum straight upstream and downstream distances must be observed. According to the pipe's design, necessary distances can be bigger or use a flow conditioner to obtain the best result. The most important layouts that could lead to turbulence in the flow are shown below, together with the associated prescribed minimum inlet and outlet distances determined according to the standard EN ISO 5167-1

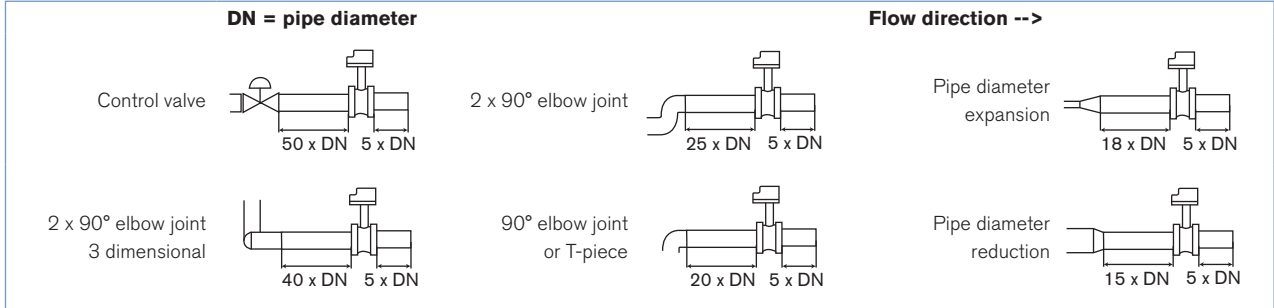

The device can be installed into either horizontal or vertical pipes.

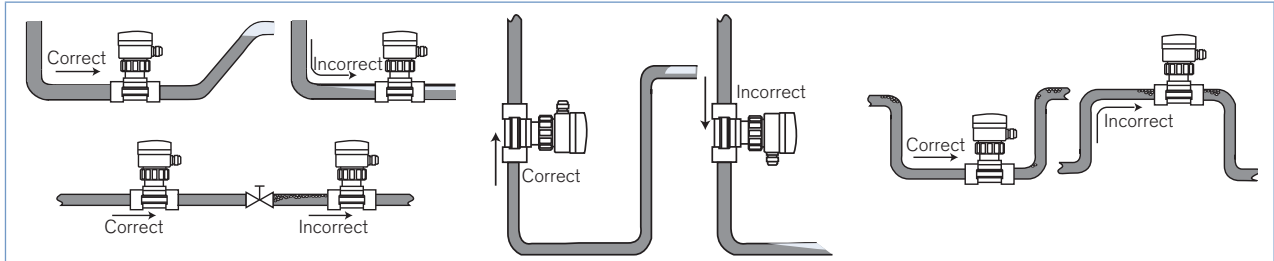

Analytical measurement:

For pH and O.R.P. measurements, we recommended a "U"- form bypass installation to ensure that the electrode is maintained in a wet condition and enable the customer to calibrate the unit without stopping the whole process or to use the special designed measuring chamber. The specially designed measuring chamber enables to install all pH-, O.R.P.-, conductivity- meters in all pipe systems, either directly in the main stream or in a by-pass line. Additionally it enables to keep the electrode always wet and isolates it easily from the main stream for calibration purposes.

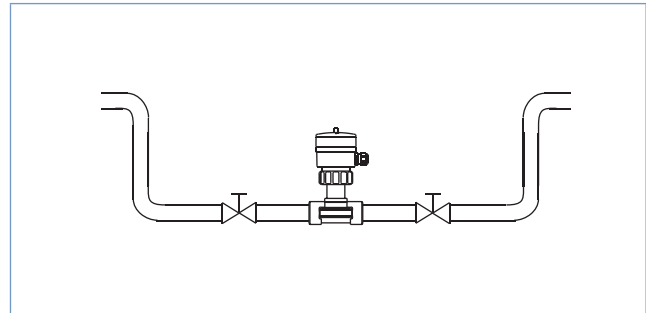

Pressure and temperature ratings must be in accordance to the selected fitting material. The suitable pipe size is selected using the diagram Flow/ Velocity/DN.

Diagram Flow/Velocity/DN

Example:

- Flow: 10 m³/h
- Ideal flow velocity: 2... 3 m/s

For these specifications, the diagram indicates a pipe size of DN40 [or DN50 for (*) mentioned fittings]

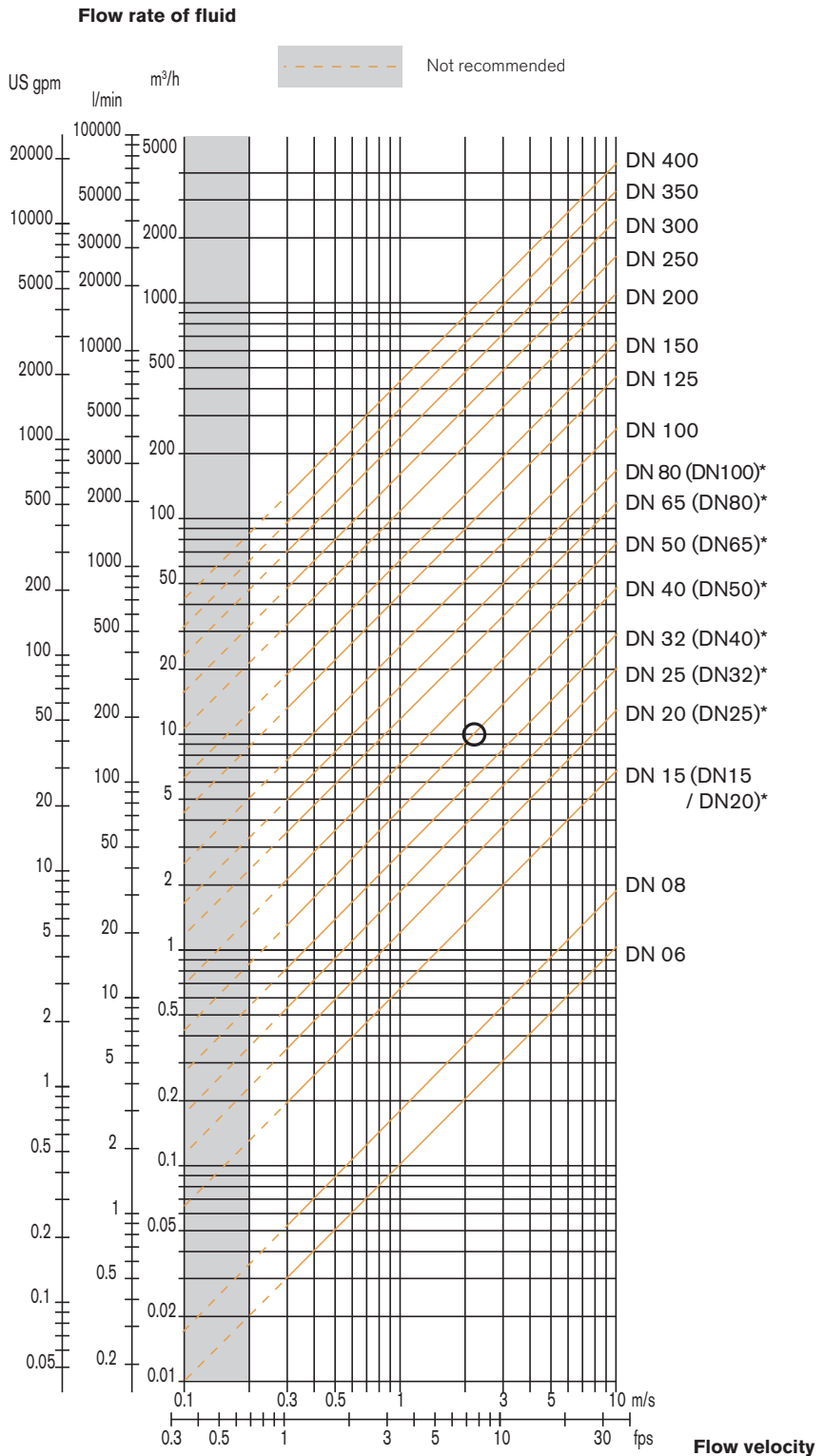

* for following fittings with:
 - external threads acc. to SMS 1145
 - weld ends acc. to SMS 3008, BS4825-1/ASME BPE/DIN 11866 series C or DIN 11850 series 2/DIN 11866 series A/DIN EN 10357 series A
 - Clamp acc. to SMS 3017, BS 4825-3/ASME BPE or DIN 32676 series A

INSERTION fitting dimensions

Fitting for flowmeter with G2" connection

Internal thread process connection

G, NPT or Rc
in stainless steel (316L - 1.4404) or
brass (CuZn39Pb2)

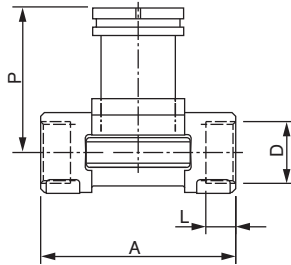

NOTE:
short sensor version

DN	P	A	D	L
[mm]	[mm]	[mm]	[inch]	[mm]
15	80.3	84.0	G 1/2 NPT 1/2 Rc 1/2	16.0 17.0 15.0
20	77.8	94.0	G 3/4 NPT 3/4 Rc 3/4	17.0 18.3 16.3
25	78.0	104.0	G 1 NPT 1 Rc 1	23.5 18.0 18.0
32	81.6	119.0	G 1 1/4 NPT 1 1/4 Rc 1 1/4	23.5 21.0 21.0
40	85.4	129.0	G 1 1/2 NPT 1 1/2 Rc 1 1/2	23.5 20.0 19.0
50	91.5	148.5	G 2 NPT 2 Rc 2	27.5 24.0 24.0

External thread process connection

G,
in stainless steel (316L - 1.4404),
brass (CuZn39Pb2),
PVC (only DN6 and DN8)

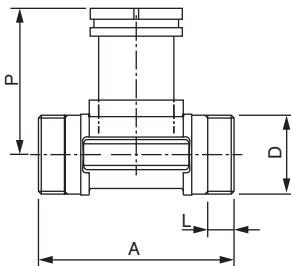

NOTE:
short sensor version

DN	P	A	D		L
[mm]	[mm]	[mm]	[inch]	[mm]	[mm]
06	75.3	90.0	G 1/2	-	14.0
08	75.3	90.0	G 1/2	-	14.0
15	80.3	84.0	G 3/4	-	11.5
20	77.8	94.0	G 1	-	13.5
25	78.0	104.0	G 1 1/4	-	14.0
32	81.6	119.0	G 1 1/2	-	18.0
40	85.4	129.0	-	M 55 x 2	19.0
50	91.5	148.5	-	M 64 x 2	20.0

External thread process connection

SMS 1145,
in stainless steel (316L - 1.4404)

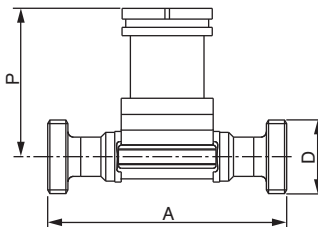

NOTE:
short sensor version

DN	P	A	D
[mm]	[mm]	[mm]	
25	77.8	130	Rd 40 x 1/6"
40	81.6	164	Rd 60 x 1/6"
50	85.4	173	Rd 70 x 1/6"

INSERTION fitting dimensions, continued

Fitting for flowmeter with G2" connection

Weld end process connection

EN ISO 1127/ISO 4200/DIN 11866 series B,
SMS 3008 or
BS 4825-1/ASME BPE/DIN 11866 series C
in stainless steel (316L - 1.4404)

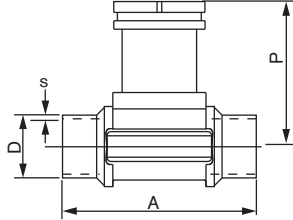

NOTE:
short sensor version

DN	P	A	Standard	D	s
[mm]	[mm]	[mm]		[mm]	[mm]
15	80.3	84.0	EN ISO 1127/ISO 4200/DIN 11866 series B	21.30	1.60
	-	-	SMS 3008	-	-
	-	-	ASME BPE/DIN 11866 series C	-	-
20	77.8	94.0	EN ISO 1127/ISO 4200/DIN 11866 series B	26.9	1.60
	-	-	SMS 3008	-	-
	83.3	84.0	ASME BPE/DIN 11866 series C	19.05	1.65
25	78.0	104.0	EN ISO 1127/ISO 4200/DIN 11866 series B	33.70	2.00
	77.8	94.0	SMS 3008	25.00	1.20
	77.8	94.0	BS 4825-1/ASME BPE/DIN 11866 series C	25.40	1.65
32	81.6	119.0	EN ISO 1127/ISO 4200/DIN 11866 series B	42.40	2.00
	-	-	SMS 3008	-	-
	78.0	104.0	BS 4825-1/ASME BPE/DIN 11866 series C	32.00	1.65
40	85.4	129.0	EN ISO 1127/ISO 4200/DIN 11866 series B	48.30	2.00
	81.6	119.0	SMS 3008	38.00	1.20
	81.6	119.0	BS 4825-1/ASME BPE/DIN 11866 series C	38.10	1.65
50	91.5	148.5	EN ISO 1127/ISO 4200/DIN 11866 series B	60.30	2.60
	85.4	128.0	SMS 3008	51.00	1.20
	85.4	128.0	BS 4825-1/ASME BPE/DIN 11866 series C	50.80	1.65
65	-	-	EN ISO 1127/ISO 4200/DIN 11866 series B	-	-
	91.5	147.0	SMS 3008	63.50	1.60
	91.5	147.0	BS 4825-1/ASME BPE/DIN 11866 series C	63.50	1.65

Clamp process connection

DIN 32676 series B,
SMS 3017* or BS 4825-3/ASME BPE*
in stainless steel (316L - 1.4404)

* Available with internal surface finish Ra = 0.8 µm

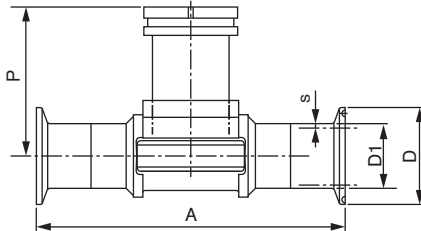

NOTE:
short sensor version

DN	P	A	Standard	D1	s	D
[mm]	[mm]	[mm]		[mm]	[mm]	[mm]
15	80.3	130	DIN 32676 series B ¹⁾	21.30	1.6	34.0
	-	-	SMS 3017	-	-	-
	-	-	ASME BPE	-	-	-
20	77.8	150	DIN 32676 series B	26.90	1.6	50.5
	-	-	SMS 3017	-	-	-
	80.3	119	ASME BPE	19.05	1.65	25.0
25	78.0	160	DIN 32676 series B	33.70	2.0	50.5
	77.8	129	SMS 3017	25.0	1.2	50.5
	77.8	129	BS 4825-3/ASME BPE	25.40	1.65	50.5
32	81.6	180	DIN 32676 series B	42.40	2.0	50.5
	-	-	SMS 3017	-	-	50.5
	-	-	BS 4825-3/ASME BPE	-	-	-
40	85.4	200	DIN 32676 series B	48.30	2.0	64.0
	81.6	161	SMS 3017	38.00	1.2	50.5
	81.6	161	BS 4825-3/ASME BPE	38.10	1.65	50.5
50	91.5	230	DIN 32676 series B	60.30	2.0	77.5
	85.4	192	SMS 3017	51.00	1.2	64.0
	85.4	192	BS 4825-3/ASME BPE	50.8	1.65	64.0
65	-	-	DIN 32676 series B	-	-	-
	91.5	216	SMS 3017	63.50	1.65	77.5
	91.5	216	BS 4825-3/ASME BPE	63.50	1.65	77.5

¹⁾ similar to DIN 32767 series B but with clamp 34.0

INSERTION fitting dimensions, continued

Fitting for flowmeter with G2" connection

Flange process connection
 EN1092-1 (ISO PN16), ANSI B16-5-1988
 in stainless steel (316L - 1.4404)

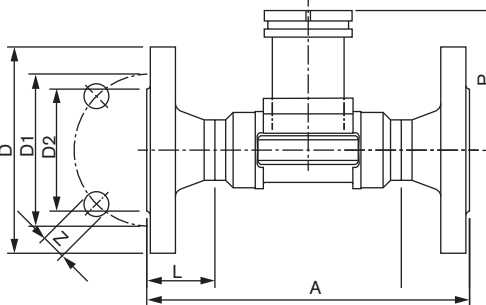

DN	P	A	Standard	L	Z	D2	D1	D
[mm]	[mm]	[mm]		[mm]	[mm]	[mm]	[mm]	[mm]
15	80.3	130	EN	23.5	4 x 14.0	45.0	65.0	95.0
		130	ANSI		4 x 15.8			
20	77.8	150	EN	28.5	4 x 14.0	58.0	75.0	105.0
		150	ANSI		4 x 15.8			
25	78.0	160	EN	28.5	4 x 14.0	68.0	85.0	115.0
		160	ANSI		4 x 15.8			
32	81.6	180	EN	31.0	4 x 18.0	78.0	100.0	140.0
		180	ANSI		4 x 15.8			
40	85.4	200	EN	36.0	4 x 18.0	88.0	110.0	150.0
		200	ANSI		4 x 15.8			
50	91.5	230	EN	41.0	4 x 18.0	102.0	125.0	165.0
		230	ANSI		4 x 19.0			

NOTE:
 short sensor version

True union process connection
 DIN 8063, ASTM D 1785/76 or JIS K in PVC,
 DIN 16962 in PP or
 ISO 10931 in PVDF

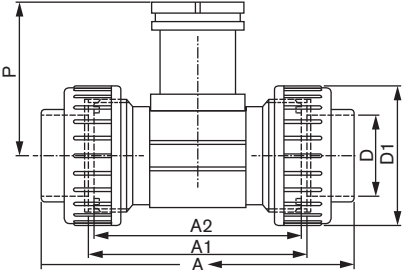

DN	P	A	Standard	A1	A2	D	D1
[mm]	[mm]	[mm]		[mm]	[mm]	[mm]	[mm]
15	80.4	128.0	DIN/ISO	96	90	20.00	43
		130.0	ASTM	96	90	21.30	43
		129.0	JIS	96	90	18.40	43
15*	81.4	148.0	DIN/ISO	116	110	20.00	74
20	77.8	144.0	DIN/ISO	106	100	25.00	53
		145.6	ASTM	106	100	26.70	53
		145.0	JIS	106	100	26.45	53
20*	81.4	154.0	DIN/ISO	116	110	25.00	74
25	78.0	160.0	DIN/ISO	116	110	32.00	60
		161.4	ASTM	116	110	33.40	60
		161.0	JIS	116	110	32.55	60
25*	81.4	160.0	DIN/ISO	116	110	32.00	74
32	81.4	168.0	DIN/ISO	116	110	40.00	74
		170.0	ASTM			42.20	
		169.0	JIS			38.60	
40	85.2	188.0	DIN/ISO	127	120	50.00	83
		190.2	ASTM			48.30	
		190.0	JIS			48.70	
50	91.5	212.0	DIN/ISO	136	130	63.00	103
		213.6	ASTM			60.30	
		213.0	JIS			60.80	

NOTE:
 short sensor version

* Analytical version

INSERTION fitting dimensions, continued

Fitting for flowmeter with G2" connection

Spigot process connection

DIN 8063 in PVC
 DIN 16962 in PP or
 ISO 10931 in PVDF

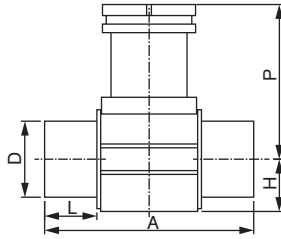

NOTE:
 short sensor version

DN [mm]	P [mm]	A [mm]	Standard	L [mm]	D [mm]	H [mm]
15	80.4	90	DIN 8063	16.5	20	17.5
		85	DIN 16962	14.0		
		85	ISO 10931	14.0		
20	77.8	100	DIN 8063	20.0	25	17.5
		92	DIN 16962	16.0		
		92	ISO 10931	16.0		
25	78.0	110	DIN 8063	23.0	32	21.5
		95	DIN 16962	18.0		
		95	ISO 10931	18.0		
32	81.4	110	DIN 8063	27.5	40	27.5
		100	DIN 16962	20.0		
		100	ISO 10931	20.0		
40	85.2	120	DIN 8063	30.0	50	31.5
		106	DIN 16962	23.0		
		106	ISO 10931	23.0		
50	91.5	130	DIN 8063	37.0	63	39.5
		110	DIN 16962	27.0		
		110	ISO 10931	27.0		

Welding socket with radius

in stainless steel (316L - 1.4404)

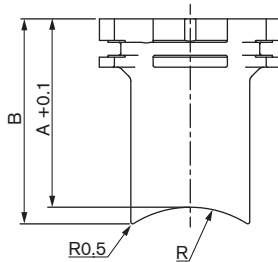

NOTE:
 sensor version:
 - short for DN50 - DN200
 - long for DN250 - DN350

DN [mm]	A [mm]	B [mm]	R [mm]
50	56.6	61.6	30.2
65	54.5	58.6	36.7
80	53.1	56.4	44.5
100	50.7	53.2	57.2
125	48.2	50.3	70.7
150	45.7	47.4	84.2
200	41.0	42.3	109.6
250	73.6	74.7	136.6
300	67.8	68.7	162.0
350	63.9	64.7	177.8

Saddle

in PP & PVC

Body material: PP & PVC adapter
 Seal material: EPDM

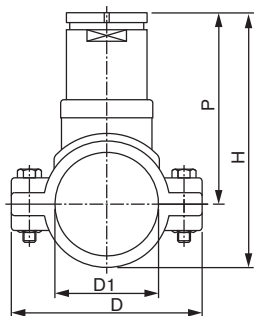

NOTE:
 long sensor version

DN [mm]	P [mm]	H [mm]	D [mm]	D1 [mm]
50	116.0	155	116	63
65	115.0	160	129	75
80	119.0	171	144	90
100	124.0	187	166	110
110	120.0	191	181	125
125	127.0	205	196	140
150	137.0	225	216	160
180	161.0	271	266	200
200	173.0	291	290	225

INSERTION fitting dimensions, continued

Fitting for flowmeter with G2" connection

Fusion spigot
in PE, PP or PVDF

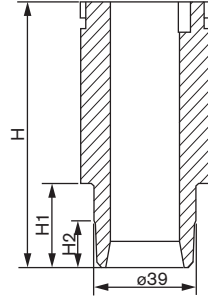

NOTE:
sensor version:
- short for DN65 - DN100
- long for DN125 - DN400

DN [mm]	H [mm]	Materials	H1 [mm]	H2 [mm]
65	72.5	PE	13.0	-
		PP	13.0	-
		PVDF	10.4	-
80	72.5	PE	15.6	-
		PP	15.6	-
		PVDF	12.5	-
100	72.5	PE	19.0	5.0
		PP	19.0	5.0
		PVDF	15.2	6.0
125	102.0	PE	24.2	8.0
		PP	-	-
		PVDF	-	-
150	102.0	PE	27.7	10.0
		PP	27.7	10.0
		PVDF	-	-
200	102.0	PE	38.9	16.0
		PP	38.9	16.0
		PVDF	-	-
250	102.0	PE	48.4	21.0
		PP	48.4	21.0
		PVDF	-	-
300	102.0	PE	54.5	24.0
		PP	54.5	24.0
		PVDF	-	-
350	102.0	PE	61.3	28.0
		PP	61.3	28.0
		PVDF	-	-
400	102.0	PE	69.1	31.5
		PP	-	-
		PVDF	-	-

Screw-on
DN100 to 400
in PVC, PP, PE

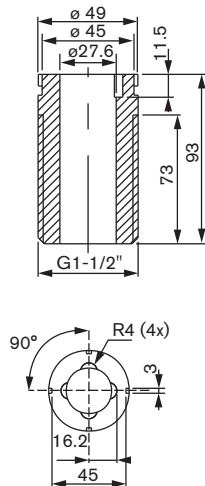

NOTE:
long sensor version

Measuring chamber (only for Analytical measuring device)

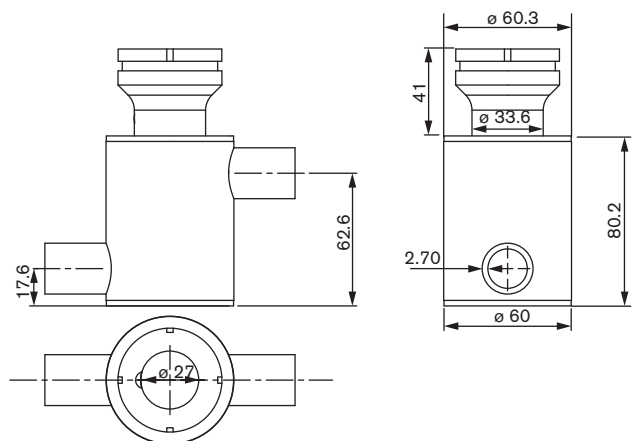

NOTE:
Materials: stainless steel 316L - 1.4404
Pipe connection: G 1/2"

INSERTION fitting dimensions, continued

Fitting for flowmeter with clamp connection

Weld end process connection

SMS 3008, BS 4825-1/ASME BPE/DIN 11866 series C or DIN 11850 series 2/DIN 11866 series A/DIN EN 10357 series A in stainless steel 316L

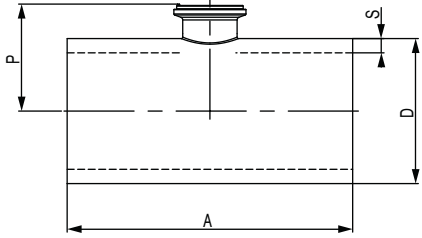

DN	P	A	Standard	D	s
[mm]	[mm]	[mm]		[mm]	[mm]
40	42.5	140	SMS 3008	38	1.2
	43.7	120.6	ASME BPE/DIN 11866 series C	38.1	1.65
	44.3	120	DIN 11850 s. 2/DIN 11866 s. A/DIN EN 10357 s. A	41	1.5
50	49.3	164	SMS 3008	51	1.2
	50.6	146	BS 4825-1/ASME BPE/DIN 11866 series C	50.8	1.65
	50.8	160	DIN 11850 s. 2/DIN 11866 s. A/DIN EN 10357 s. A	53	2
65	54.4	210	SMS 3008	63.5	1.6
	55.4	158.8	BS 4825-1/ASME BPE/DIN 11866 series C	63.5	1.65
	59.6	210	DIN 11850 s. 2/DIN 11866 s. A/DIN EN 10357 s. A	70	2
80	60.7	220	SMS 3008	76.1	1.6
	62	171.5	BS 4825-1/ASME BPE/DIN 11866 series C	76.2	1.65
	67.3	260	DIN 11850 s. 2/DIN 11866 s. A/DIN EN 10357 s. A	85	2
100	73.8	209.6	BS 4825-1/ASME BPE/DIN 11866 series C	101.6	2.11
	77.1	310	DIN 11850 s. 2/DIN 11866 s. A/DIN EN 10357 s. A	104	2

Welding socket

in stainless steel 316L

①

SMS 3008 or
DIN 11850 series 2/DIN 11866 series A/DIN EN 10357 series A

②

BS 4825-1/ASME BPE/DIN 11866 series C

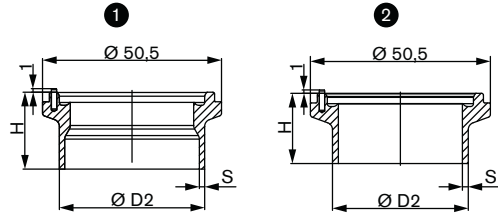

DN	Standard	H	S	D2
[mm]		[mm]	[mm]	[mm]
40	SMS 3008	21.7	1.2	38
	ASME BPE/DIN 11866 series C	23.7	1.65	38.1
	DIN 11850 s. 2/DIN 11866 s. A/DIN EN 10357 s. A	21.7	1.5	41
50	SMS 3008	21.7	1.2	38
	BS 4825-1/ASME BPE/DIN 11866 series C	23.7	1.65	38.1
	DIN 11850 s. 2/DIN 11866 s. A/DIN EN 10357 s. A	21.7	1.5	41
65	SMS 3008	19.7	1.2	38
	BS 4825-1/ASME BPE/DIN 11866 series C	19.7	1.65	38.1
	DIN 11850 s. 2/DIN 11866 s. A/DIN EN 10357 s. A	21.7	1.5	41
80	SMS 3008	19.7	1.2	38
	BS 4825-1/ASME BPE/DIN 11866 series C	19.7	1.65	38.1
	DIN 11850 s. 2/DIN 11866 s. A/DIN EN 10357 s. A	21.7	1.5	41
100	BS 4825-1/ASME BPE/DIN 11866 series C	19.7	1.65	38.1
	DIN 11850 s. 2/DIN 11866 s. A/DIN EN 10357 s. A	19.7	1.5	41

Ordering chart for fitting S020

Fitting for flowmeter with G2" connection
DN6 to DN65

Port connection	Seal	Standard	Item no. DN06 - 1/2"	Item no. DN08 - 1/2"	Item no. DN15	Item no. DN20	Item no. DN25	Item no. DN32	Item no. DN40	Item no. DN50	Item no. DN65
Brass body & stainless steel adapter - T-fitting - Medium temperature max. 160°C, PN16											
Internal thread	FKM	G	-	-	428 712	428 713	428 714	428 715	428 716	428 717	-
		NPT	-	-	428 718	428 719	428 720	428 721	428 722	428 723	-
		Rc (ISO7)	-	-	428 724	428 725	428 726	428 727	428 728	428 729	-
External thread	FKM	G	-	-	428 730	428 731	428 732	428 733	428 734	428 735	-
Stainless steel body & stainless steel adapter - T-fitting - Medium temperature max. 160°C, PN16											
Internal thread	FKM	G	-	-	428 736	428 737	428 738	428 739	428 740	428 741	-
		NPT	-	-	428 742	428 743	428 744	428 745	428 746	428 747	-
		Rc (ISO7)	-	-	428 748	428 749	428 750	428 751	428 752	428 753	-
External thread	FKM	G	552 434	552 432	428 754	428 755	428 756	428 757	428 758	428 759	-
	EPDM	SMS 1145	-	-	-	-	443 317	-	443 318	443 319	-
Weld end	FKM	EN ISO 1127/ISO 4200/ DIN 11866 series B	-	-	428 760 ³⁾	428 761	428 762	428 763	428 764	428 765	-
	EPDM	SMS 3008	-	-	-	-	443 309	-	443 310	443 311	443 944 ²⁾
	EPDM	BS 4825-1/ASME BPE/ DIN 11866 series C	-	-	-	443 734 ¹⁾	443 735	443 736	443 942	443 943	443 944
Clamp	FKM	DIN 32676 series B	-	-	428 766	428 767	428 768	428 769	428 770	428 771	-
	EPDM	SMS 3017	-	-	-	-	443 313	-	443 314	443 315	443 969 ²⁾
		SMS 3017*	-	-	-	-	443 957	-	443 958	443 959	443 974 ²⁾
		BS 4825-3/ASME BPE	-	-	-	443 965 ¹⁾	443 966	-	443 967	443 968	443 969
	EPDM	BS 4825-3/ASME BPE*	-	-	-	443 970	443 971	-	443 972	443 973	443 974
Flange	FKM	EN 1092-1	-	-	428 772	428 773	428 774	428 775	428 776	428 777	-
		ANSI B16-5-1988	-	-	428 778	428 779	428 780	428 781	428 782	428 783	-
PVC & PVC adapter - T-fitting - Medium temperature max. 50°C, PN10											
True union	FKM	DIN 8063	-	-	428 670	428 671	428 672	428 673	428 674	428 675	-
		ASTM D 1785/76	-	-	428 682	428 683	428 684	428 685	428 686	428 687	-
		JIS K	-	-	429 078	429 079	429 080	429 081	429 082	429 083	-
Spigot	FKM	DIN 8063	-	-	428 676	428 677	428 678	428 679	428 680	428 681	-
External thread	FKM	G	552 561	550 062	-	-	-	-	-	-	-
Analytical true union	FKM	DIN 8063	-	-	430 837	430 838	430 839	428 673	428 674	428 675	-
PP & PP adapter - T-fitting - Medium temperature max. 80°C, PN10											
True union	FKM	DIN 16962	-	-	428 688	428 689	428 690	428 691	428 692	428 693	-
Spigot	FKM	DIN 16962	-	-	428 694	428 695	428 696	428 697	428 698	428 699	-
Analytical true union	FKM	DIN 16962	-	-	430 840	430 841	430 842	428 691	428 692	428 693	-
PVDF & PVDF adapter - T-fitting - Medium temperature max. 100°C, PN10											
True union	FKM	ISO 10931	-	-	428 700	428 701	428 702	428 703	428 704	428 705	-
Spigot	FKM	ISO 10931	-	-	428 706	428 707	428 708	428 709	428 710	428 711	-
Analytical true union	FKM	ISO 10931	-	-	430 843	430 844	430 845	428 703	428 704	428 705	-

* internal surface finish Ra = 0.8 µm

¹⁾ DN20 only available in ASME BPE

²⁾ Please refer to ASME BPE

³⁾ Refer to Clamp with D dimensions of 34 mm (see dimension table on page 6)

Ordering chart for fitting S020

**Fitting for flowmeter with G2" connection
DN50 to DN400**

Port connection	Item no. DN50	Item no. DN65	Item no. DN80	Item no. DN100	Item no. DN125	Item no. DN150	Item no. DN200	Item no. DN250	Item no. DN300	Item no. DN350	Item no. DN400
Stainless steel - welding socket with radius - Medium temperature max. 160°C, PN16											
Welding socket	418 111	418 112	418 113	418 114	418 115	418 116	418 117	418 756	420 070	416 637	-
PVC - Screw-on fitting - Medium temperature max. 50°C, PN10											
Screw-on	-	-	-	418 170	418 170	418 170	418 170	-	-	-	-
PVDF - Fusion spigot - Medium temperature max. 100°C, PN10											
Fusion spigot	-	418 658	418 659	418 660	-	-	-	-	-	-	-
Analytical fusion spigot	-	418 660	418 660	418 660	-	-	-	-	-	-	-
PE - Fusion spigot or screw-on fitting - Medium temperature max. 70°C, PN10											
Fusion spigot	-	418 642	418 643	418 644	418 590	418 645	418 646	418 647	418 648	418 649	418 598
Screw-on	-	-	-	436 489	436 489	436 489	436 489	436 489	436 489	436 489	436 489
Analytical fusion spigot	-	418 644	418 644	418 644	-	-	-	-	-	-	-
PP - Fusion spigot or screw-on fitting - Medium temperature max. 80°C, PN10											
Fusion spigot	-	418 650	418 651	418 652	-	418 653	418 654	418 655	418 656	418 657	-
Screw-on	-	-	-	436 488	436 488	436 488	436 488	436 488	436 488	436 488	436 488
Analytical fusion spigot	-	418 652	418 652	418 652	-	-	-	-	-	-	-
Port connection	Seal	Item no. DN50	Item no. DN65	Item no. DN80	Item no. DN100	Item no. DN110	Item no. DN125	Item no. DN150	Item no. DN180	Item no. DN200	
PP & PVC adapter - Saddle - Medium temperature max. 60°C, PN10 (for PVC or PP pipe)											
Saddle	EPDM	425 138	425 139	425 140	425 141	425 142	425 143	425 144	433 873	425 416	

* internal surface finish Ra = 0.8 µm

¹⁾ DN20 only available in ASME BPE

**Fitting for flowmeter with clamp connection (Type 8041/8045 clamp version)
DN32 to DN100**

Port connection	Standard	Item no. DN32 PN16	Item no. DN40 PN16	Item no. DN50 PN16	Item no. DN65 PN16	Item no. DN80 PN16	Item no. DN100 PN10
Stainless steel T-fitting - Medium temperature max. 160°C							
Weld end	SMS 3008	-	564 915	564 916	564 917	564 918	**
	BS 4825-1/ASME BPE/DIN 11866 series C	-	564 920	564 921	564 922	564 923	564 924
	DIN 11850 series 2/DIN 11866 series A/ DIN EN 10357 series A	-	564 925	564 926	564 927	564 928	564 929
Stainless steel socket - Medium temperature max. 160°C							
Welding socket	SMS 3008	-	564 696	564 696	564 697	564 697	**
	BS 4825-1/ASME BPE/DIN 11866 series C	-	564 698	564 698	564 699	564 699	564 699
	DIN 11850 series 2/DIN 11866 series A/ DIN EN 10357 series A	-	565 069	565 069	565 069	565 069	565 390

** please refer to BS 4825-1/ASME BPE/DIN 11866 series C or to DIN 11850 series 2/DIN 11866 series A/DIN EN 10357 series A

i Further versions on request

Process connection
EN ISO 1127/ISO 4200/DIN 11866 series B (DN32 to DN80)

Ordering chart for accessories/spare parts (other versions on request)

Fitting for flowmeter with G2" connection

Description	Item no.
Stopper with ring, union nut and O-ring	
Stainless steel	438 755
PVC	438 754
PP	627 614
Adapter with 4 screws (DN06 to DN65)	
Stainless steel	555 484
PVC	561 175
PP	561 176
PVDF	561 177
O-Ring set (DN06 to DN65)	
FKM - for metal fitting (5 units)	428 971
EPDM - for metal fitting (5 units)	428 972
FKM - for plastic fitting (1 flat gasket + 1 O-ring)	561 043
EPDM - for plastic fitting (1 flat gasket + 1 O-ring)	561 044
Measuring chamber	
Stainless steel ¹⁾ 316L- 1.4404	553 611

¹⁾ other material on request

Fitting for flowmeter with clamp connection

Description	Item no.
1 EPDM fitting/flowmeter seal	730 837
1 FEP fitting/flowmeter seal	730 839
Clamp collar	731 164
Stopper for fitting	565 200

Approvals/Certificates for both versions

Description	Item no.
Inspection certificate 3.1 (acc. to EN-ISO 10204)	803 723
Test report 2.2 (acc. to EN-ISO 10204)	803 722
3 points Flow calibration certificate (S020 combined with the flow device inserted, only for DN ≤ 200)	550 676
Certification of Conformity for the surface Quality (DIN4762-DIN4768-ISO/4287/1)	804 175
FDA approval	803 724

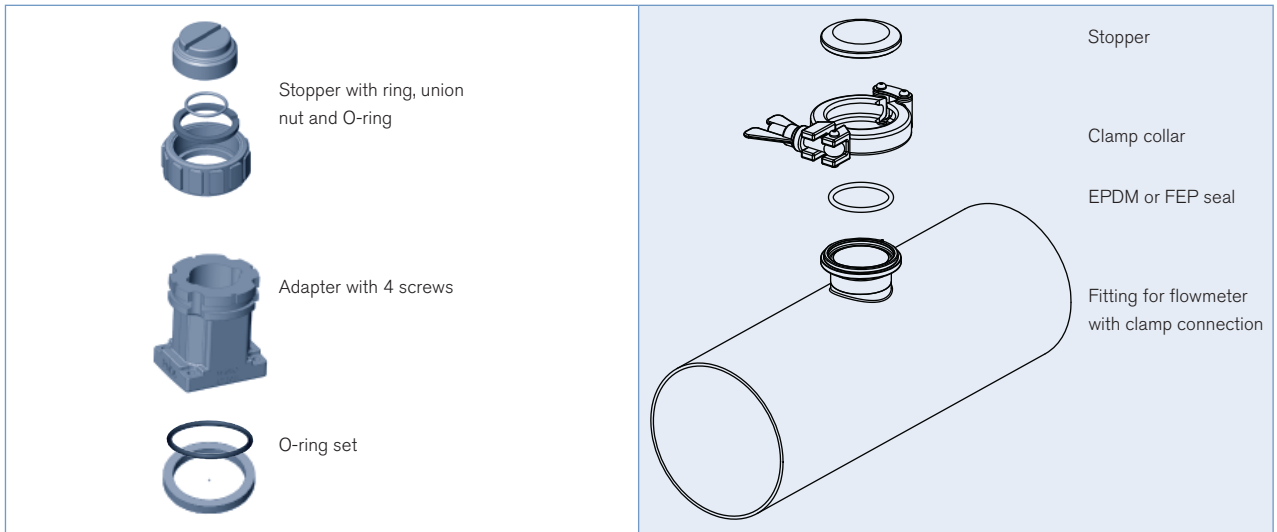

Interconnection possibilities with the S020

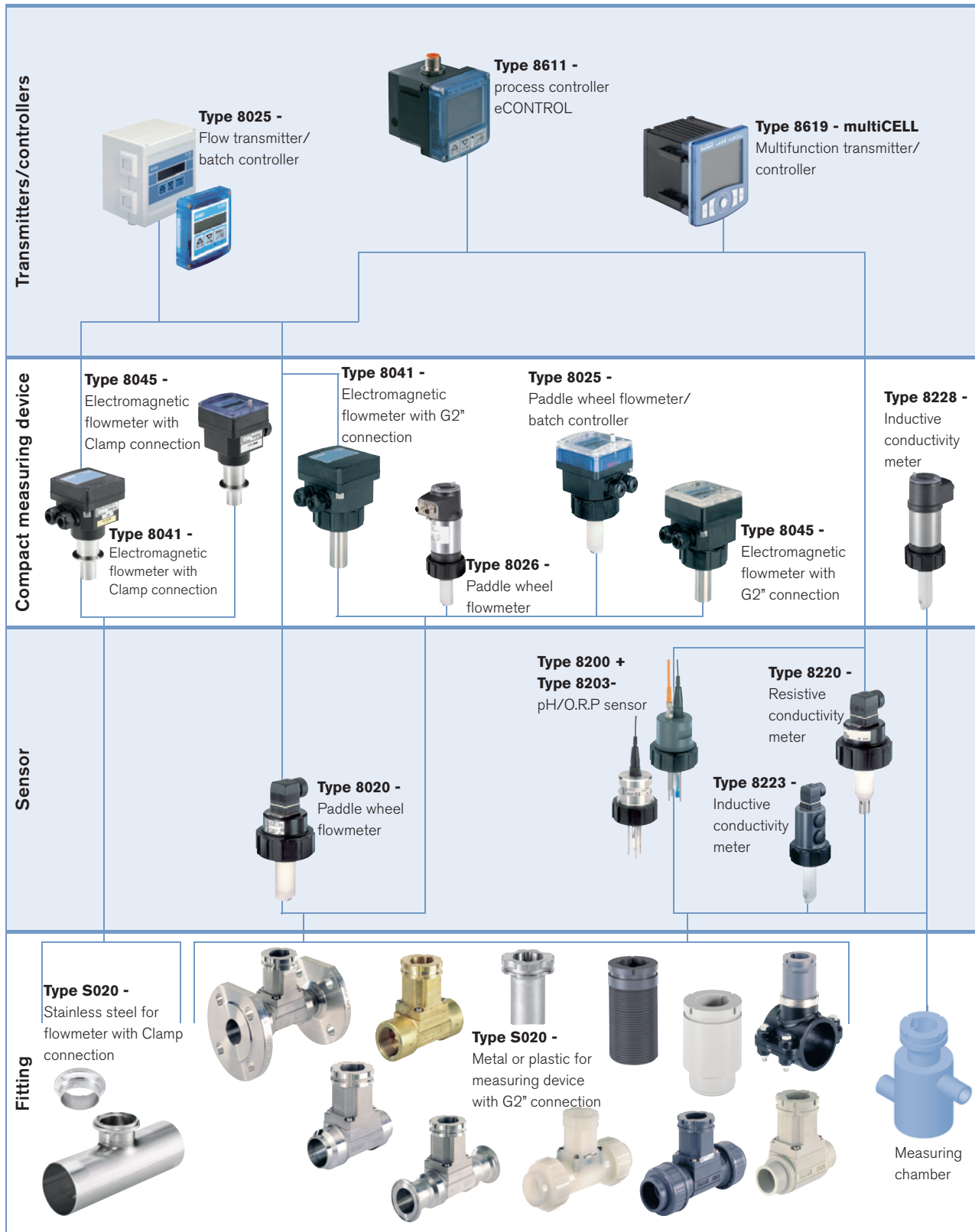

DTS 1000011768 EN Version: AB Status: RL (released | freigegeben | valide) printed: 21.04.2015

In case of special application conditions,
please consult for advice.

Subject to alteration.
© Christian Bürkert GmbH & Co. KG

1504/16_EU-en_00891872