





Zero Deadleg T Valve, pneumatically operated, stainless steel block material

- Fully integrated in Burkert's Process Control Systems
- Zero dead volume
- Monoblock – no welds
- Quality certifications  / 

Type 2032 can be combined with...



Type 6012

Solenoid
banjo valve



Stroke limitation

Min./max. stroke
limitation



Type 1062

Electrical position
feedback



Type 8631

TopControl On/Off



Type 8630

Positioner Top-
Control continuous

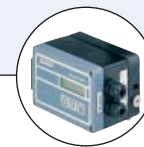

Type 1067

SideControl
Positioner

The Burkert Zero Deadleg T Valve system is designed for control of ultra pure, sterile, aggressive or abrasive fluids. Enables especially optimal sampling, draining or diverting of critical process fluids. The valve body is machined from a single piece of block material (monoblock – no weld seam).

The high quality diaphragms separate hermetically critical fluids from the actuator. The pneumatic actuator can be controlled by pneumatic pilot valves (single pilot valves, valve islands and control heads). Control function A, normally closed by spring return.

Technical data			
Orifice	DN 8-80		
Body materials	<ul style="list-style-type: none"> ▪ Stainless steel 1.4435 / 316 L ▪ Stainless steel 1.4435BN2 / ASME BPE Fe < 0.5% / C ≤ 0.03%		
Diaphragm materials	EPDM, PTFE/EPDM, TFM/EPDM		
Actuator materials	PPS, PA		
Pilot air ports	Stainless steel 1.4305		
Surface finish	Ra [µm] internal	Ra [µlnch] internal	Ra [Grit #] internal
satin finished	0.5	20	240
electro polished	0.4	16	280
mirror finished	0.25	10	330
Media temperature	-10° to +130°C (briefly up to +150°C)		
Ambient temperature	Actuator size < 100 mm +5° to +140°C Actuator size 100-125 mm +5° to +90°C (briefly up to +140°C) Actuator size ≥ 175 mm -10° to +50°C		
Control media	Neutral gases; air		
Pilot pressure max.	max. 7 bar, see table on p. 2		
Port connections	<ul style="list-style-type: none"> ▪ EN ISO 1127 / ISO 4200 ▪ DIN 11850 Series 0 to 3 ▪ SMS 3008 ▪ ASME BPE ▪ BS 4825 		
Weld end acc. to	<ul style="list-style-type: none"> ▪ EN ISO 1127 / ISO 4200 ▪ DIN 11850 Series 0 to 3 ▪ SMS 3008 ▪ ASME BPE ▪ BS 4825 		
Clamp acc. to	<ul style="list-style-type: none"> ▪ ISO 2852 ▪ ASME BPE ▪ DIN 32676 		
Installation for selfdraining operation	Actuator inclined 3 to 5° downwards		

Technical data, continued

Orifice DN diaphragm [mm]	Actuator size Ø [mm]	Kv-value water [m³/h]	Pilot pressure [bar]	Max. operating pressure (medium) for seal material	
				EPDM [bar]	PTFE/EPDM [bar]
8	40	1.0	5.0-7	10	10
15	50	4.0	5.0-7	8.5	5
	63	4.5	5.0-7	10	10
20	63	7.0	5.5-7	10	5
	80	7.5	5.0-7	10	10
25	63	12.0	5.0-7	3	–
	80	12.0	5.5-7	10	7.5
40	100	30.0	5.5-7	6.5	6
	125	30.5	5.5-7	10	10
50	100	51.5	5.5-7	4.5	2.5
	125	51.5	5.5-7	8	7
80	225	160.0	5.0-6	10	10

Approvals/certifications

- Certification of Conformity for Raw Material EN-ISO 10204 3.1
- Attestation of compliance with the order EN-ISO 10204 2.1
- Test report EN-ISO 10204 2.2
- 3A Certification
- Certification of Conformity for Pickling and Electropolishing Processes
- Certification of Conformity for the Surface Quality DIN4762-DIN4768-ISO/4287/1
- Attestation of compliance with FDA CFR No. 21.177.1550 for PTFE/EPDM and TFM/EPDM and 21.177.2600 for EPDM
- USP CLASS VI certification for EPDM and PTFE diaphragm
- Test Certification and Conformity Certification for the Final Assembly of Diaphragm Valves
- ISO 9001 Certification

Note: Retrospective manufacturing certification for process diaphragm valves can not be made, therefore please notify when ordering.

Materials

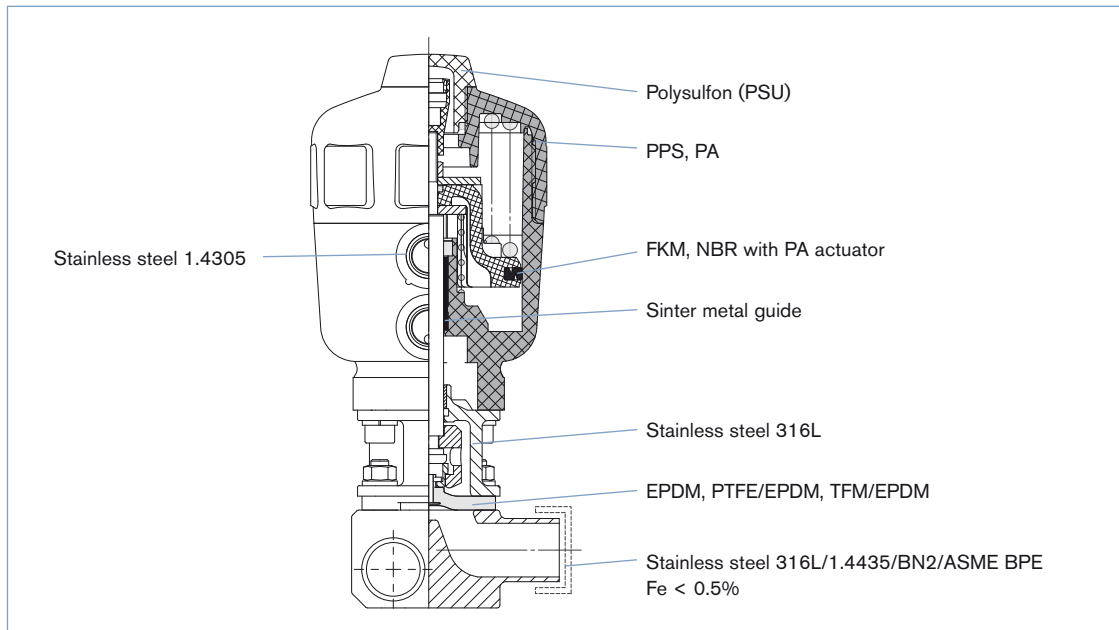

Example of available diaphragm materials

Developed to handle the unique challenges of hygienic and sterile applications, Bürkert offers diaphragms with precise material formula and physical tolerances. Bürkert diaphragms are available in a wide range of materials which have been proven in food & beverage, biotechnology, pharmaceutical and cosmetic industry applications. Diaphragms are tested during development and production to ensure reliability in critical processing environments.

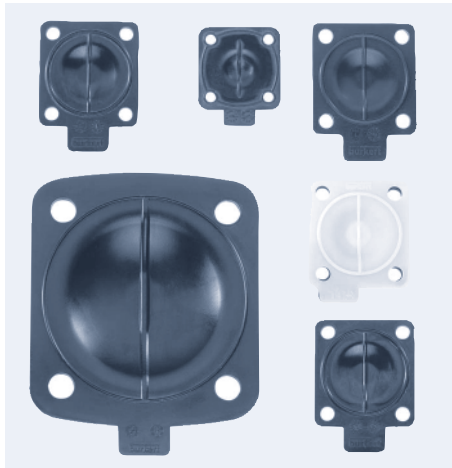

- EPDM (Ethylene Propylene Rubber)
- PTFE/EPDM
- TFM/EPDM
- FKM
- PTFE/FKM
- NBR

Dimensions [mm]

Welded body acc. to EN ISO 1127/ISO 4200

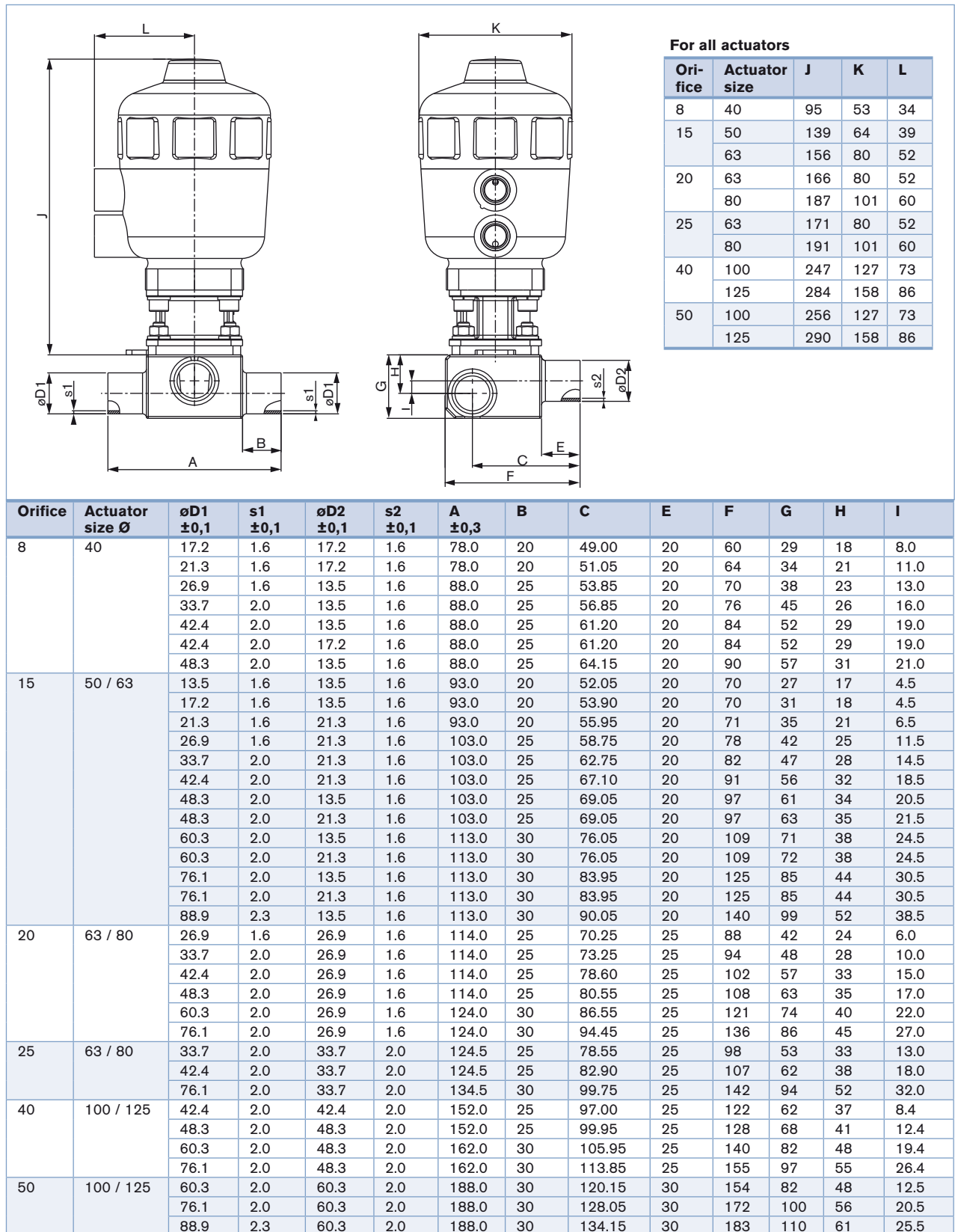

DTS 1000011282 EN Version: G Status: RL (released | freigegeben | validé) printed: 23.09.2008

Dimensions [mm], continued

Welded body acc. to ASME BPE

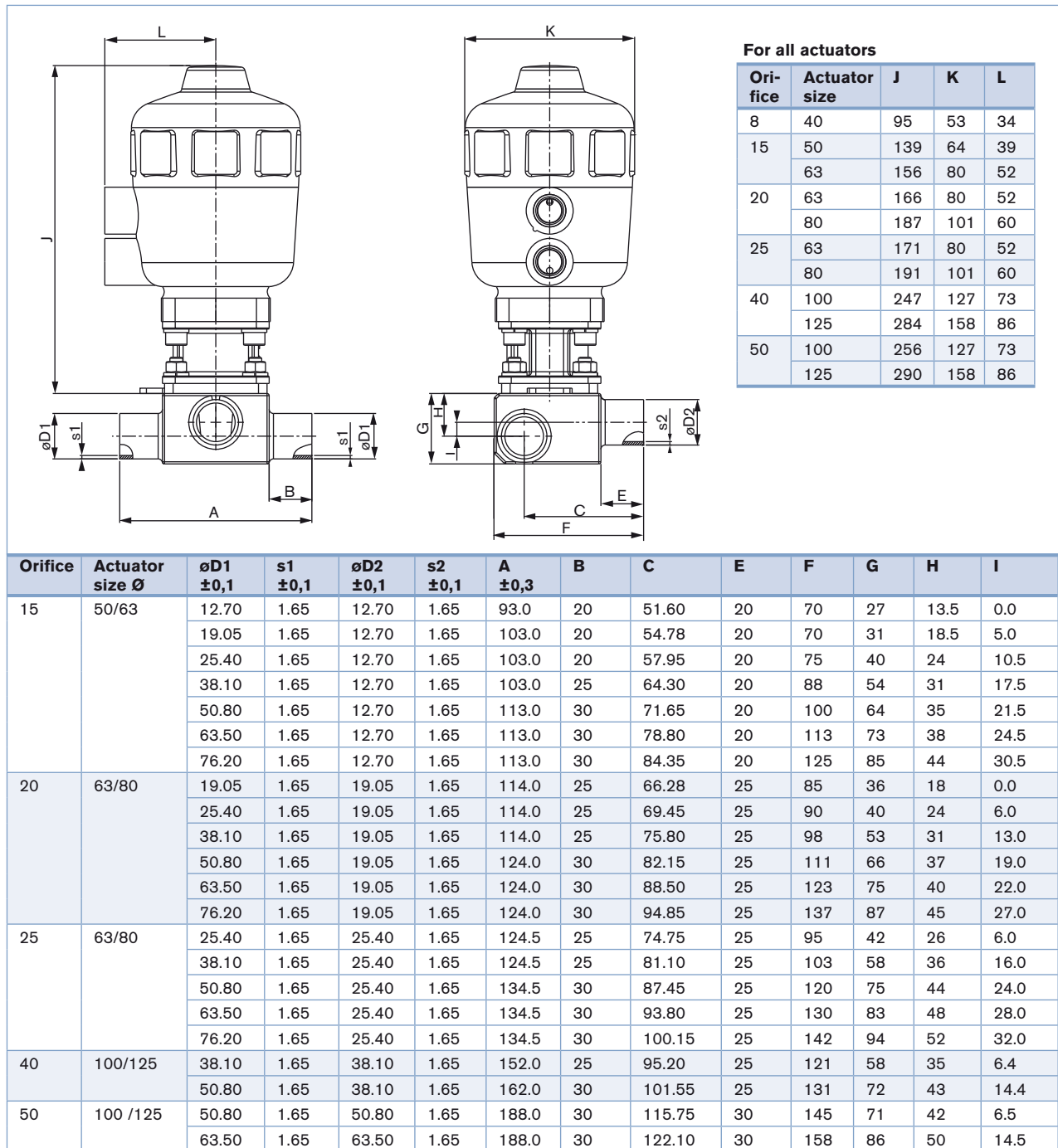

Dimensions [mm], continued

Welded body acc. to DIN 11850 Series 0 and 2

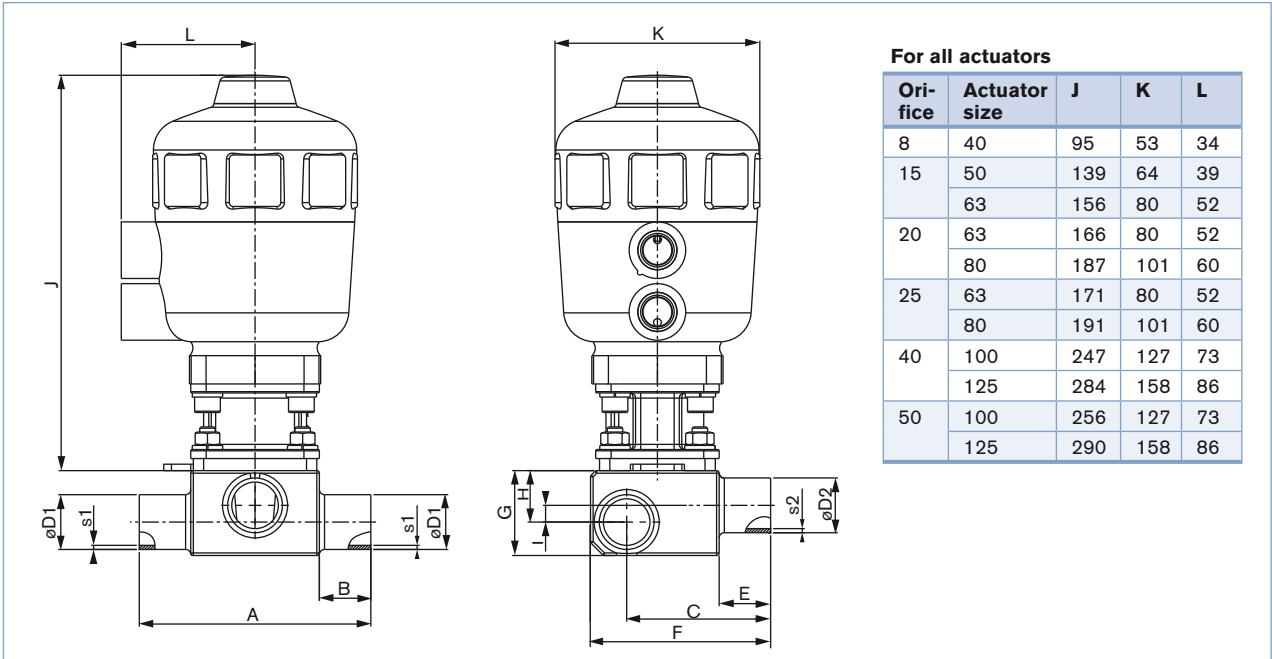

For all actuators

Orifice	Actuator size	J	K	L
8	40	95	53	34
15	50	139	64	39
	63	156	80	52
20	63	166	80	52
	80	187	101	60
25	63	171	80	52
	80	191	101	60
40	100	247	127	73
	125	284	158	86
50	100	256	127	73
	125	290	158	86

Orifice	Actuator size Ø	øD1 ±0,1	s1 ±0,1	øD2 ±0,1	s2 ±0,1	A ±0,3	B	C	E	F	G	H	I
Series 0													
08	40	6.0	1.0	6.0	1.0	78.0	20	43.0	20	60	17	6.5	0.0
		40.0	1.5	6.0	1.0	88.0	25	60.5	20	83	51	29	19.0
		40.0	1.5	10.0	1.0	88.0	25	60.5	20	83	51	29	19.0
		52.0	1.5	6.0	1.0	98.0	30	66.5	20	95	60	32	22.0
25	63/80	28.0	1.5	28.0	1.5	124.5	25	76.2	25	95	46	29	9.0
		52.0	1.5	28.0	1.5	134.5	30	88.2	25	117	71	42	22.0
40	100/125	28.0	1.5	34.0	1.5	152.0	25	90.3	25	122	58	32	3.4
		52.0	1.5	34.0	1.5	162.0	30	102.3	25	132	75	45	16.4
50	100/125	52.0	1.5	52.0	1.5	188.0	30	116.5	30	147	73	43	7.5
Series 2													
15	50/63	19.0	1.5	19.0	1.5	93.0	20	54.9	20	70	33	20	6.5
		23.0	1.5	19.0	1.5	103.0	20	56.9	20	72	37	22.5	8.5
		35.0	1.5	19.0	1.5	103.0	25	62.9	20	84	50	29	14.5
		41.0	1.5	19.0	1.5	103.0	25	65.9	20	91	56	32	18.5
20	63/80	23.0	1.5	23.0	1.5	114.0	25	68.4	25	88	42	21	3.0
		35.0	1.5	23.0	1.5	114.0	25	74.4	25	95	50	29	11.0
		41.0	1.5	23.0	1.5	114.0	25	77.4	25	101	56	32	14.0
25	63/80	29.0	1.5	29.0	1.5	124.5	25	76.7	25	98	48	30	10.0
40	100/125	41.0	1.5	41.0	1.5	152.0	25	96.8	25	121	62	37	8.4
50	100/125	53.0	1.5	53.0	1.5	188.0	30	117.0	30	147	74	44	8.5

Dimensions [mm], continued

Welded body acc. to SMS 3008

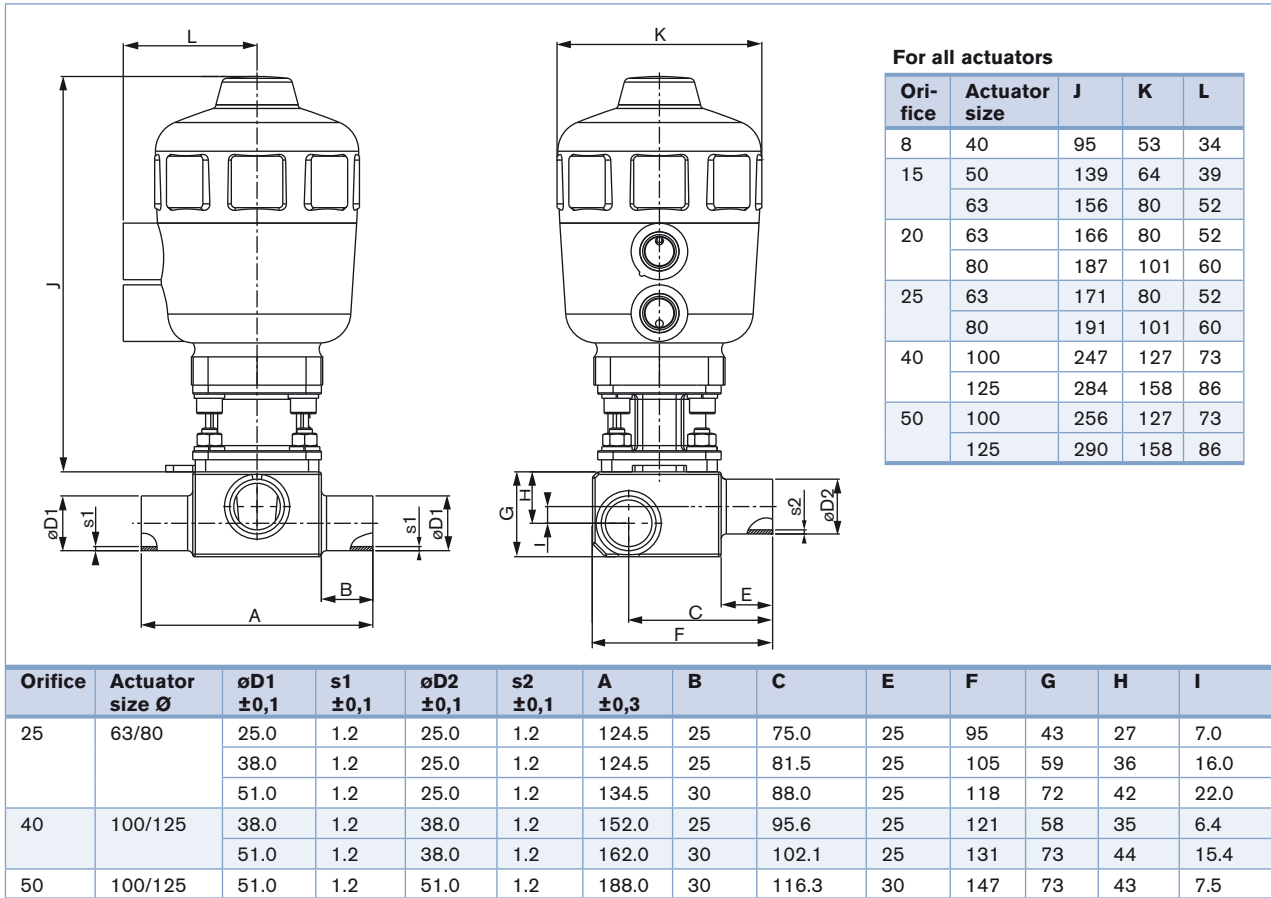

Dimensions [mm], continued

Clamp body

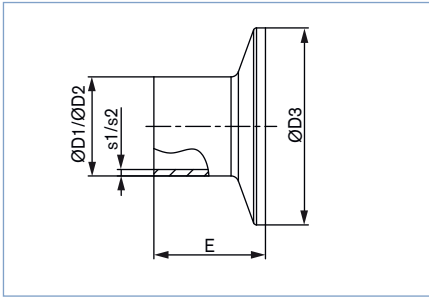

ASME BPE

DN	D1/D2	s1/s2	D3	E
08 - 1/4"	6.35	0.89	25.0	28.6
10 - 3/8"	9.53	0.89	25.0	28.6
15 - 1/2"	12.7	1.65	25.0	28.6
20 - 3/4"	19.05	1.65	25.0	28.6
25 - 1"	25.4	1.65	50.5	28.6
40 - 1 1/2"	38.1	1.65	50.5	28.6
50 - 2"	50.8	1.65	64.0	28.6
65 - 2 1/2"	63.5	1.65	77.5	28.6
80 - 3"	76.2	1.65	91.0	28.6
100 - 4"	101.6	2.11	119.0	28.6

DIN 32676

DN	D1/D2	s1/s2	D3	E
10	13	1.5	34.0	18
15	19	1.5	34.0	18
20	23	1.5	34.0	18
25	29	1.5	50.5	21.5
32	35	1.5	50.5	21.5
40	41	1.5	50.5	21.5
50	53	1.5	64.0	21.5
65	70	2.0	91.0	28

ISO2852 for pipe ISO 4200

DN	D1/D2	s1/s2	D3	E
8	13.5	1.6	25.0	28.6
8	13.5	1.6	34.0	28.6
10	17.2	1.6	34.0	28.6
15	21.3	1.6	34.0	28.6
15	21.3	1.6	50.5	28.6
20	26.9	1.6	50.5	28.6
25	33.7	2	50.5	28.6
32	42.4	2	50.5	28.6
40	48.3	2	64.0	28.6
50	60.3	2	77.5	28.6
65	76.1	2	91.0	28.6
100	114.3	2.3	130.0	28.6

SMS

DN	D1/D2	s1/s2	D3	E
25	25	1.2	50.5	21.5
40	38	1.2	50.5	28.6
50	51	1.2	64.0	28.6

Valve features

Example

A 15 AB B VH SA42 SA42 D E NO22 + NO14

Specification key

Please make a choice

CONTROL FUNCTION

A	normally closed by spring action
B	normally open by spring action
I	double acting

ORIFICE [mm] (diaphragm)

8
15
20
25
40
50
80

DIAPHRAGM MATERIAL

AB	EPDM in food quality
EA	PTFE
FF	FKM
EU	TFM

PRODUCTION OF BODY

B	Monoblock
---	-----------

BODY MATERIAL

VH	1.4435/AISI 316L
VI	1.4435BN2/ASME BPE

VARIABLE CODES

Surface finish, external

NO03	Ext. Mirror finished Ra=0.25 µm	
NO15	Ext. Electro polished Ra=0.8µm	
NO19	Ext. Mech. polished Ra=1.6µm	
NO22	Ext. Glassbeaded Ra= 3.2 µm	standard

Surface finish, internal

NO07	Int. Mirror finished Ra=0.25 µm	
NO14	Int. Satin finished Ra=0.5µm	standard
NO17	Int. Electro finished Ra=0.4µm	
NO20	Int. Electro polished Ra=0.25µm	

ACTUATOR SIZE ¹⁾

C	ø 40 mm
D	ø 50 mm
E	ø 63 mm
F	ø 80 mm
G	ø 100 mm
H	ø 125 mm
K	ø 175 mm
L	ø 225 mm

¹⁾ for technical spec. see table, page 2

ACTUATOR MATERIAL

C	PA (for actuator sizes ø175/225 mm)
D	PPS

øD1 main tube connection

øD2 outlet tube connection

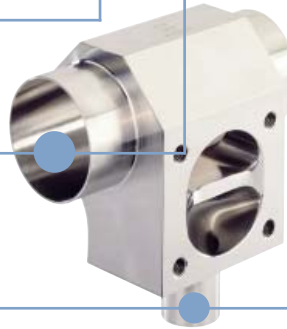

Port connection weld end

Orifice DN [mm]	EN ISO 1127/ ISO 4200	SMS 3008	DIN 11850 Series 0	Series 1	Series 2	Series 3	BS 4825	ASME BPE	JIS Sanitary	JIS Utility
4			SC40=6x1.0							
6			SC41=8x1.0							
8	SA40=13.5x1.6		SC42=10x1.0				SODB=6.35x1.2	SA90=6.35x0.89	SA70=13.8x1.65	
10	SA41=17.2x1.6			SF40=12x1.0	SD40=13x1.5	SE40=14x20.0	SODC=9.53x1.2	SA91=9.53x0.89	SA71=17.3x1.65	
15	SA42=21.3x1.6		SC43=18x1.5	SF41=18x1.0	SD42=19x1.5	SE42=20x2.0	SODD=12.7x1.2	SA92=12.7x1.65	SA72=21.7x2.1	
20	SA43=26.9x1.6		SC44=22x1.5	SF42=22x1.0	SD43=23x1.5	SE43=24x2.0	SODE=19.05x1.2	SA93=19.05x1.65	SA76=27.2x2.1	SA80=27.2x2.1
25	SA44=33.7x2.0	SA60=25.0x1.2	SC45=28x1.5	SF43=28x1.0	SD44=29x1.5	SE44=30x2.0		SODF=25.4x1.65	SA73=25.4x1.2	SA81=34x2.0
32	SA45=42.4x2.0		SC46=34x1.5	SF44=34x1.0	SD45=35x1.5	SE45=36x2.0				SA83=42.7x2.0
40	SA46=48.3x2.0	SA62=38.0x1.2	SC47=40x1.5	SF45=40x1.0	SD46=41x1.5	SE46=42x2.0	SODH=38.1x1.65	SA74=38.1x1.2	SA83=48.6x2.0	
50	SA47=60.3x2.0	SA63=51.0x1.2	SC48=52x1.5	SF46=52x1.0	SD47=53x1.5	SE47=54x2.0	SODI=50.8x1.65	SA75=50.8x1.5	SA84=60.5x2.0	
65	SA48=76.1x2.0	SA64=63.5x1.6			SD48=70x2.0		SODJ=63.5x1.65			
80	SA49=88.9x2.3	SA65=76.1x1.6			SD49=85x2.0		SODK=76.2x1.65			
100	SA39=114.3x2.3	SA66=101.6x2.0			SD50=104x2.0		SODL=101.6x2.11			

Port connection Clamp

Orifice DN [mm]	ISO 2852 SMS 3017	ASME BPE	DIN 32676
8	TC51=Clamp 34 - for tube ISO 4200	TG50=Clamp 25 - Tube 6.35x0.89	
10	TC41=Clamp 34 - for tube ISO 4200	TG01=Clamp 25 - Tube 9.53x0.89	TD41=Clamp 34 - Tube 13x1.5
15	TC42=Clamp 34 - for tube ISO 4200	TG02=Clamp 25 - Tube 12.7x1.65	TD42=Clamp 34 - Tube 19x1.5
20	TC43=Clamp 50.5 - for tube ISO 4200	TG03=Clamp 25 - Tube 19.05x1.65	TD43=Clamp 34 - Tube 23x1.5
25	TC44=Clamp 50.5 - for tube ISO 4200	TG04=Clamp 50.5 - Tube 25.4x1.65	TD44=Clamp 50.5 - Tube 29x1.5
40	TC46=Clamp 64 - for tube ISO 4200	TG05=Clamp 50.5 - Tube 38.1x1.65	TD46=Clamp 50.5 - Tube 41x1.5
50	TC47=Clamp 77.5 - for tube ISO 4200	TG06=Clamp 64 - Tube 50.8x1.65	TD47=Clamp 64 - Tube 53x1.5

In case of special application conditions, please consult for advice.

Subject to alteration.
© Christian Bürkert GmbH & Co. KG

0809/5_EU-en_00891852