

Defensor PH28/PH28A

Adiabatic Humidifiers



OPERATING INSTRUCTIONS

Contents

1	Introduction	4	6	Maintenance	28
1.1	To the very beginning	4	6.1	Maintenance intervals	28
1.2	Notes on the operating instructions	4	6.2	Maintenance work	29
2	For your safety	6	6.2.1	Disassembling the unit	29
3	Product Overview	8	6.2.2	Cleaning work	30
3.1	Unit versions	8	6.3	Notes on cleaning agent	32
3.2	Unit construction	8	6.4	Reassembly of the unit	33
3.3	Operating panel	9	6.5	Resetting the filter changing message	34
3.4	Identification of the unit	10	6.6	Repair work	34
3.5	Functional description/Operating modes	10	7	Fault elimination	36
3.6	Options	11	7.1	Event messages	36
3.7	Accessories	12	7.2	Warning messages	36
3.8	Standard delivery	12	7.3	Error messages	37
4	Commissioning	13	7.4	What, if...?	38
4.1	Unpacking the unit and checking the scope of delivery	13	7.5	Notes on fault elimination	39
4.2	Transporting/storing the unit	13	8	Taking out of service/Disposal	40
4.3	Choose location	14	8.1	Taking out of service	40
4.4	Connecting the water supply (PH28A only)	15	8.2	Disposal/Recycling	40
4.5	Putting the unit into operation	16	9	Unit specifications	41
5	Operation	17	10	Appendix	42
5.1	Filling the water tank (PH28 only)	17	10.1	Wiring diagram	42
5.2	Switching the unit on and off	18	10.2	Spare parts list PH28	43
5.3	Menu overview	19	10.3	Spare parts list PH28A	45
5.4	Unit settings (normal operating mode)	20			
5.4.1	Setting the desired humidity value	20			
5.4.2	Setting the fan step	21			
5.4.3	Selecting the operating mode	22			
5.4.4	Switching the buzzer on and off	22			
5.4.5	Calling timer level	23			
5.5	Program operation	24			
5.5.1	Calling the timer level	24			
5.5.2	Activating/Deactivating the program mode	25			
5.4.3	Setting the current time	25			
5.5.4	Setting the starting points and the operating programs	26			
5.6	Locking/unlocking the keyboard	27			

1 Introduction

1.1 To the very beginning

We thank you for having purchased an **air purifier/air humidifier Defensor PH28 or PH28A**.

The air purifier/air humidifier Defensor PH28/PH28A incorporates the latest technical advances and meets all recognized safety standards. Nevertheless, improper use of the Defensor PH28/PH28A may result in danger to the user or third parties and/or impairment of material assets.

To ensure a safe, proper, and economical operation of the air purifier/air humidifier Defensor PH28/PH28A, please observe and comply with all information and safety instructions contained in the present operating instructions as well as the instructions given in the manuals for the components used in the humidification system.

If you have questions, which are not or insufficiently answered in this documentation, please contact your Defensor supplier. They will be glad to assist you.

1.2 Notes on the operating instructions

Limitation

The subject of this operating instructions are the air purifiers/air humidifiers Defensor PH28 and PH28A. The various accessories are only described insofar as this is necessary for proper operation of the equipment. Further information on accessories can be obtained in the respective instructions.

This operating instructions are restricted to the **installation, commissioning, operation, servicing and trouble shooting** of the air purifier/air humidifier Defensor PH28/PH28A and is meant for **well trained personnel being sufficiently qualified for their respective work**.

The operating instructions are supplemented by various separate items of documentation (e.g. manuals for accessories). Where necessary, appropriate cross-references are made to these publications in the operating instructions.

Symbols used in this manual

CAUTION!

The catchword "CAUTION" designates notes in this operating instructions that, if neglected, may cause **damage and/or malfunction of the unit or other material assets**.

WARNING!

The catchword "WARNING" used in conjunction with the general caution symbol designates safety and danger notes in this operating instructions that, if neglected, may cause to **injury to persons**.

DANGER!

The catchword "DANGER" used in conjunction with the general caution symbol designates safety and danger notes in this operating instructions that, if neglected, may lead to **severe injury or even death of persons**.

Safekeeping

Please safeguard this operating instructions in a safe place, where it can be immediately accessed. If the equipment changes hands, the documentation should be passed on to the new operator.

If the documentation gets mislaid, please contact your Defensor supplier.

Language versions

This operating instructions are available in various languages. Please contact your Defensor supplier for information.

Copyright protection

The present operating instructions are protected under the Copyright Act. Passing-on and reproduction of the manual (or part thereof) as well as exploitation and communication of the contents are prohibited without written permission by the manufacturer. Violation of copyright terms is subject to legal prosecution and arises liability for indemnification.

The manufacturer reserves the right to fully exploit commercial patent rights.

2 For your safety

General

Every person working with the Defensor PH28/PH28A must have read and understood the Operating instructions before carrying out any work.

Knowing and understanding the contents of the Operating instructions is a basic requirement for protecting the personnel against any kind of danger, to prevent faulty operation, and to operate the unit safely and correctly.

All ideograms, signs and markings applied to the unit must be observed and kept in readable state.

Qualification of personnel

All actions described in the present Operating instructions (installation, operation, maintenance, etc.) must be carried out only by **well trained and sufficiently qualified personnel authorised by the owner**.

For safety and warranty reasons any action beyond the scope of this manuals must be carried out only by qualified personnel authorised by your Defensor supplier.

It is assumed that all persons working with the Defensor PH28/PH28A are familiar and comply with the appropriate regulations on work safety and the prevention of accidents.

This unit may not be used by persons (including children) with reduced physical, sensory or mental abilities or persons with lacking experience and/or knowledge, unless they are supervised by a person responsible for their safety or they received instructions on how to operate the unit.

Children must be supervised to make sure that they do not play with unit.

Intended use

The air purifier/air humidifier Defensor PH28/PH28A is intended exclusively for **air purification and air humidification within the specified operating conditions** (see chapter 9 "Product specifications"). Any other type of application without the express written consent of the manufacturer is considered as not conforming with the intended purpose and may lead to the Defensor PH28/PH28A becoming dangerous.

Operation of the equipment in the intended manner requires **that all the information in these instructions are observed (in particular the safety instructions)**.

Danger that may arise from the unit

DANGER! Danger of electric hazard!

The Defensor PH28/PH28A is mains powered. One may get in touch with live parts when the unit is open. Touching live parts may cause severe injury or danger to life.

Prevention: Before carrying out any work set the Defensor PH28/PH28A out of operation (switch off the unit, disconnect it from the mains, close water supply) and secure the unit against inadvertent power-up.

WARNING!

Poorly maintained humidifiers can endanger your health. If the Defensor PH28/PH28A is insufficiently maintained harmful germs can build up in the water and the filters and can affect the ambient air.

Prevention: The Defensor PH28/PH28A has to be cleaned in regular intervals according to chapter 6 "Maintenance". The cleaning work has to be carried out correctly and the evaporator mat as well as the filters have to be replaced after the specified lifetime.

Handling the mains cable

Handle the mains cable with care: keep it away from sharp edges and do not jam or strain it.

Never remove the mains plug by pulling the mains cable. Make sure your hands are absolutely dry when pulling the plug out of the socket.

Lay out the mains cable so that it does not become a stumbling trap.

Connect mains cable only to a mains socket with protection earth. Any extension cable used must be equipped with a protection earth too.

Behaviour in case of danger

If it is suspected that **safe operation is no longer possible**, then the Defensor PH28/PH28A should immediately **be disconnected from the mains (disconnect mains connector) and secured against accidental power-up**. This can be the case under the following circumstances:

- if the Defensor PH28/PH28A is damaged
- if the Defensor PH28/PH28A is no longer operating correctly
- if connections and/or piping are not sealed
- if the mains cable is damaged

All persons working with the Defensor PH28/PH28A must report any alterations to the unit that may affect safety to the owner without delay.

Prohibited modifications to the unit

No modifications must be undertaken on the Defensor PH28/PH28A without the express written consent of the manufacturer.

For the replacement of defective components use exclusively **original accessories and spare parts** available from your Defensor supplier.

3 Product Overview

3.1 Unit versions

The Defensor PH28/PH28A air purifier/air humidifier is available in two basic versions:

- **PH28:** version with integrated water tank
- **PH28A:** version with inlet valve for the connection to the drinking water system

Both versions are equipped as standard with a coarse dust filter and a flock-coated evaporator mat to operate the unit as a humidifier (winter time operation).

3.2 Unit construction

PH28

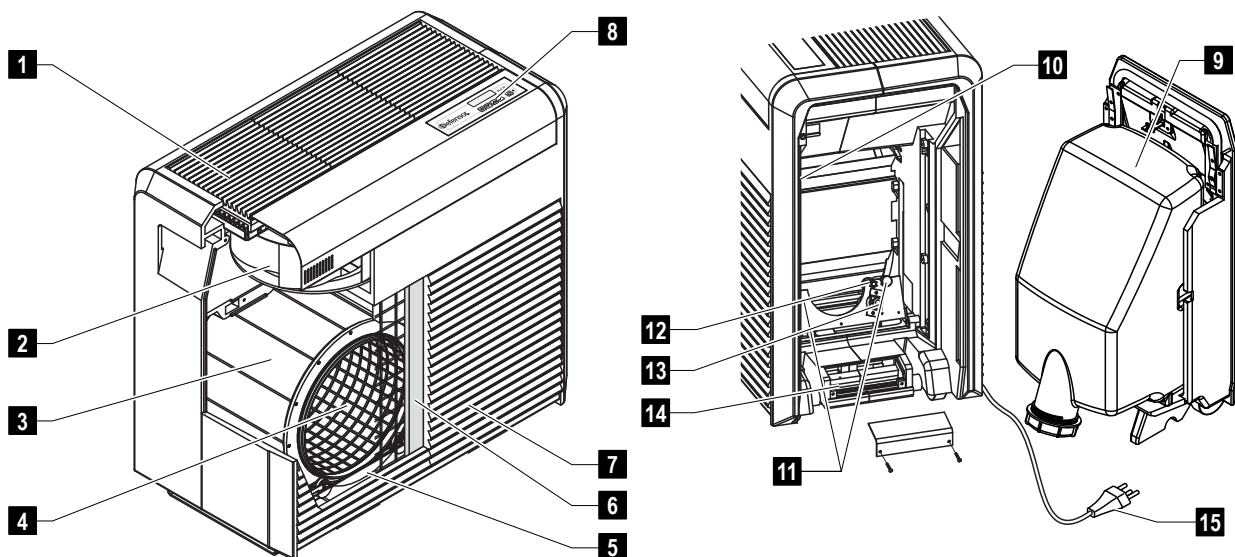

- 1 Air outlet grill
- 2 Radial fan
- 3 Rotary humidification drum
- 4 Evaporator mat
- 5 Base tub
- 6 Coarse dust filter (Option: Quattro filter)
- 7 Air intake grill
- 8 Operating panel with display

- 9 Water tank carriage
- 10 Type plate
- 11 Silver ionisation electrodes
- 12 Safety float
- 13 Level switch
- 14 Fuse
- 15 3 pole mains cable

PH28A

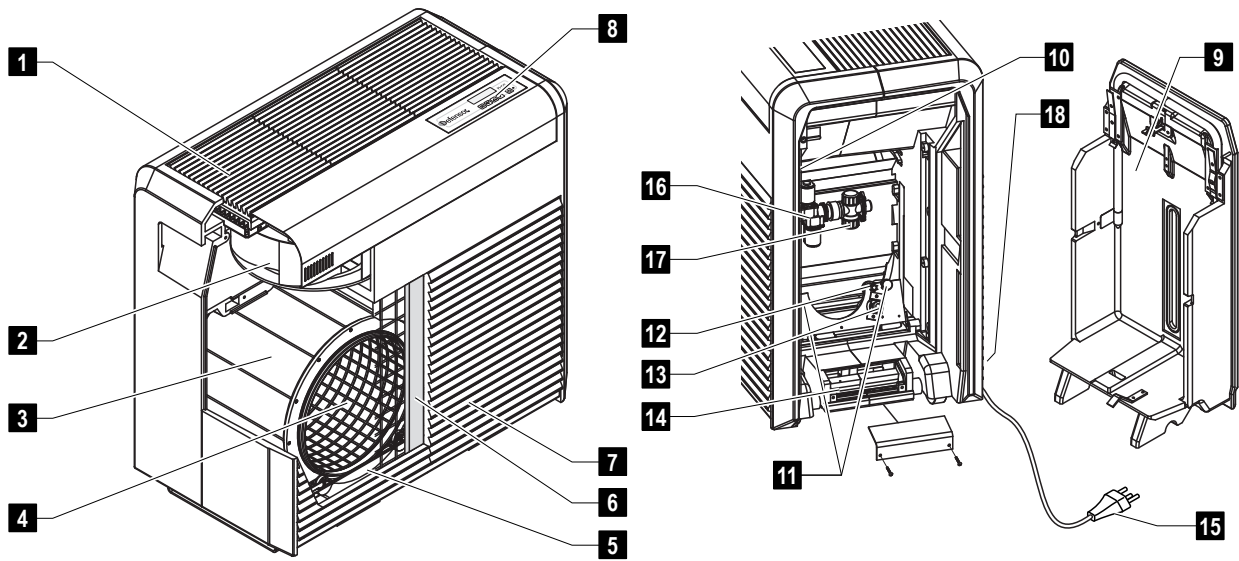

- | | | | |
|---|---|----|------------------------------|
| 1 | Air outlet grill | 10 | Type plate |
| 2 | Radial fan | 11 | Silver ionisation electrodes |
| 3 | Rotary humidification drum | 12 | Safety float |
| 4 | Evaporator mat | 13 | Level switch |
| 5 | Base tub | 14 | Fuse |
| 6 | Coarse dust filter (Option: Quattro filter) | 15 | 3 pole mains cable |
| 7 | Air intake grill | 16 | Inlet valve |
| 8 | Operating panel with display | 17 | Water filter |
| 9 | Side cover | 18 | Water supply connector |

3.3 Operating panel

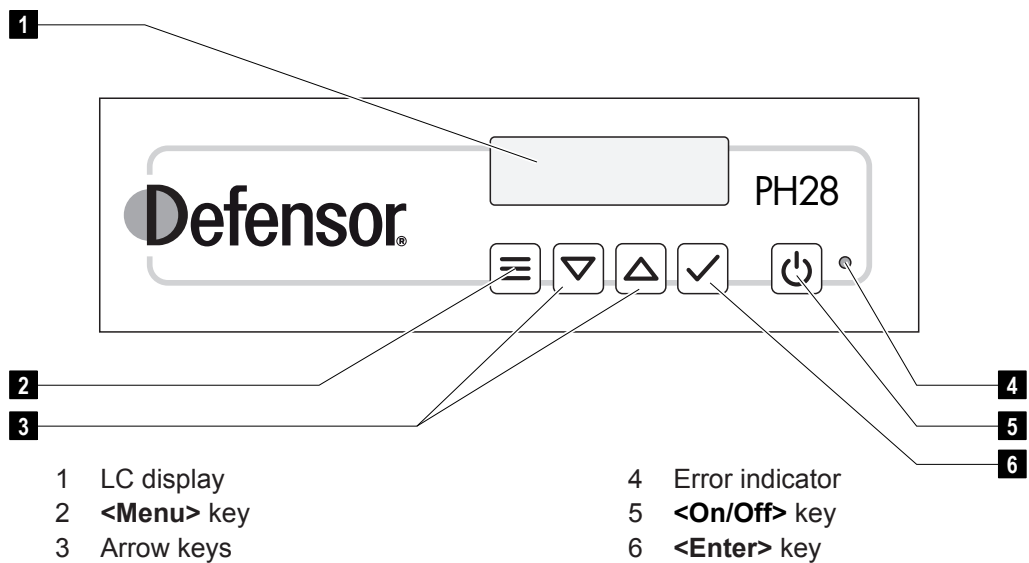

3.4 Identification of the unit

The identification of the unit is found on the type plate (for the location of the type plate see unit overview):

	Type designation	Serial number	Month/Year
Unit voltage	Walter Meier (Climate International) Ltd. 8808 Pfäffikon		
	Type: PH28A	Serial: XXXXXXX	07.11
Admissible water supply pressure (PH28A only)	Voltage: 220...240VAC / 50...60 Hz	Power: max. 128 W	
Field with certification symbols	Water pressure: 0.5...6 bar	Color code: NCS S 0300-N	
Power consumption			
Colour code	Made in Switzerland		

3.5 Functional description/Operating modes

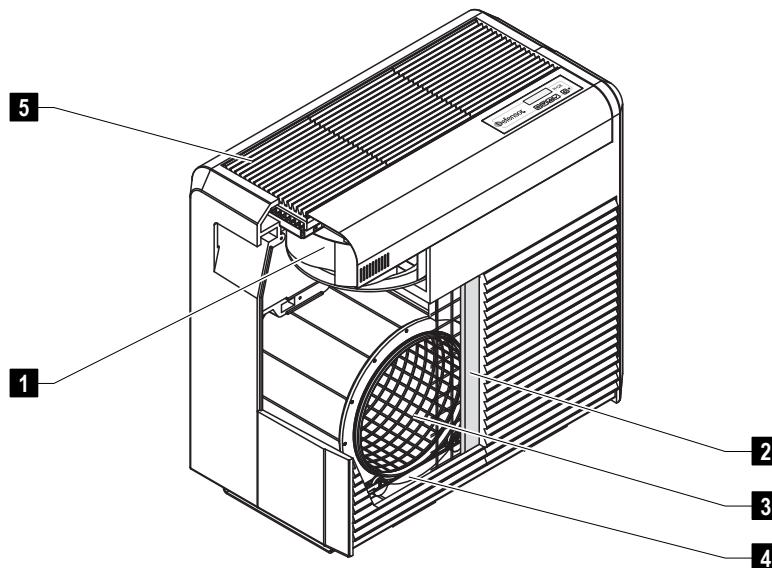

Functional description

The fan (1) takes in the air from both sides via the coarse dust filter (2) or the Quattro filter, respectively. After passing the humidification drum, the purified air is led to the air outlet grill (5) and distributed in the room.

The unit continuously measures the air humidity in the room with the integrated humidity sensor and compares it with the set reference humidity value. If the actual value (e.g. 40 %rh) is below the reference value (e.g. 45 %rh) the humidification drum (3) starts turning. The vaporizer mat is dipped into the base tub (4) and takes up water. The air passing through the humidification drum absorbs the humidity.

The coarse dust filter retains dust particles up to 100 µm. If the Defensor PH28/PH28A is equipped with a Quattro filter it can retain dust particles up to 0.1 µm. In addition the activated charcoal layer in the Quattro filter removes unpleasant odour.

The water level in the base tub is monitored by the level regulating valve in the water tank (Defensor PH28) or by the level controlled inlet valve (Defensor PH28A).

Two silver ionisation electrodes prevent the formation of slime and microorganisms in the base tub and on the humidification drum. The ionizer electrodes are active as soon as the Defensor PH28/PH28A is switched on.

Operating modes

The Defensor PH28/PH28A can be operated in the following operating modes:

– **Operation as air humidifier**

In the humidifier mode the ventilator and the humidification drum are running only, if the actual humidity value is below the set reference value.

Note: if the actual humidity value remains below the reference value for a prolonged period of time, the fan must be switched to the next highest level.

– **Operation as air purifier (without humidification)**

In this operating mode the fan is running continuously. The humidification drum remains switched off.

– **Operation as air purifier/humidifier (Combined mode)**

In this operating mode the fan is running continuously. The humidification drum is only switched on if the actual humidity value is below the set reference value.

3.6 Options

	Defensor PH28	Defensor PH28A
<p>Radio humidity sensor The radio humidity sensor can be used instead of the integrated humidity sensor. The maximum range of the radio humidity sensor in an open room is 25 m Note: the radio humidity sensor as well as the receiver board must be installed and configured only by a service technician of your Defensor representative.</p>	•	•

3.7 Accessories

	Defensor PH28	Defensor PH28A
Filter set “Winter” (optimized for air humidification) Filter set for the operation of the unit during winter season. The set consist of: – Flock-coated evaporator mat – Coarse dust filter	•	•
Filter set “Summer” (optimized for air purification) Filter set for the operation of the unit during summer season. The set consist of: – Activated carbon evaporator mat – Quattro filter	•	•
Filter valve “Z261” Filter valve to use as a shut-off valve in the water supply line (PH28A only)		•

3.8 Standard delivery

The air purifier/air humidifier Defensor PH28/PH28A is delivered in a cardboard box (W: 900 mm x H: 820 mm D: 490 mm, transport weight: 49 kg), ready for use. The **standard delivery** includes:

- **Air purifier/Air humidifier Defensor PH28 or PH28A**, equipped with the “Winter” filter set (coarse dust filter and flock-coated evaporator mat) and the options as ordered.
- **Filling hose** approx. 1,2 m (PH28 only)
- **Operating instructions** (this document)

The ordered accessories with operating instructions according chapter 3.7 are packed separately.

4 Commissioning

4.1 Unpacking the unit and checking the scope of delivery

Unpacking the unit

Open the packing and remove the unit and the accessories. Check the delivery for completeness (standard delivery, see chapter 3.8). Please contact your Defensor supplier in case something is lacking, they will be glad to send you the missing part without delay.

Please check the equipment for damage. Please report any damage to your Defensor supplier and to the carriers, as required.

Packaging

The original packaging of the Defensor PH28/PH28A was designed for optimum safety during transportation. Please preserve the original packing material in case you once have to return the unit for some reason.

In case you wish to dispose of the packaging, observe the local regulations on waste disposal. Never dispose of the packaging to the environment.

4.2 Transporting/storing the unit

Transport

The Defensor PH28/PH28A is equipped with built-in rollers for effortless displacement. If you have to lift the unit for displacement or relocation ask another person for assistance (weight of the empty unit: 43 kg).

CAUTION!

To prevent the water from running out make sure the water tank and the base tub are empty before moving the unit.

Storing

Store the unit in a protected area meeting the following requirements:

- room temperature: 1 ... 40 °C
- room humidity: 10 ... 75 %rh

4.3 Choose location

Please observe the following notes for the correct positioning of the Defensor PH28/PH28A:

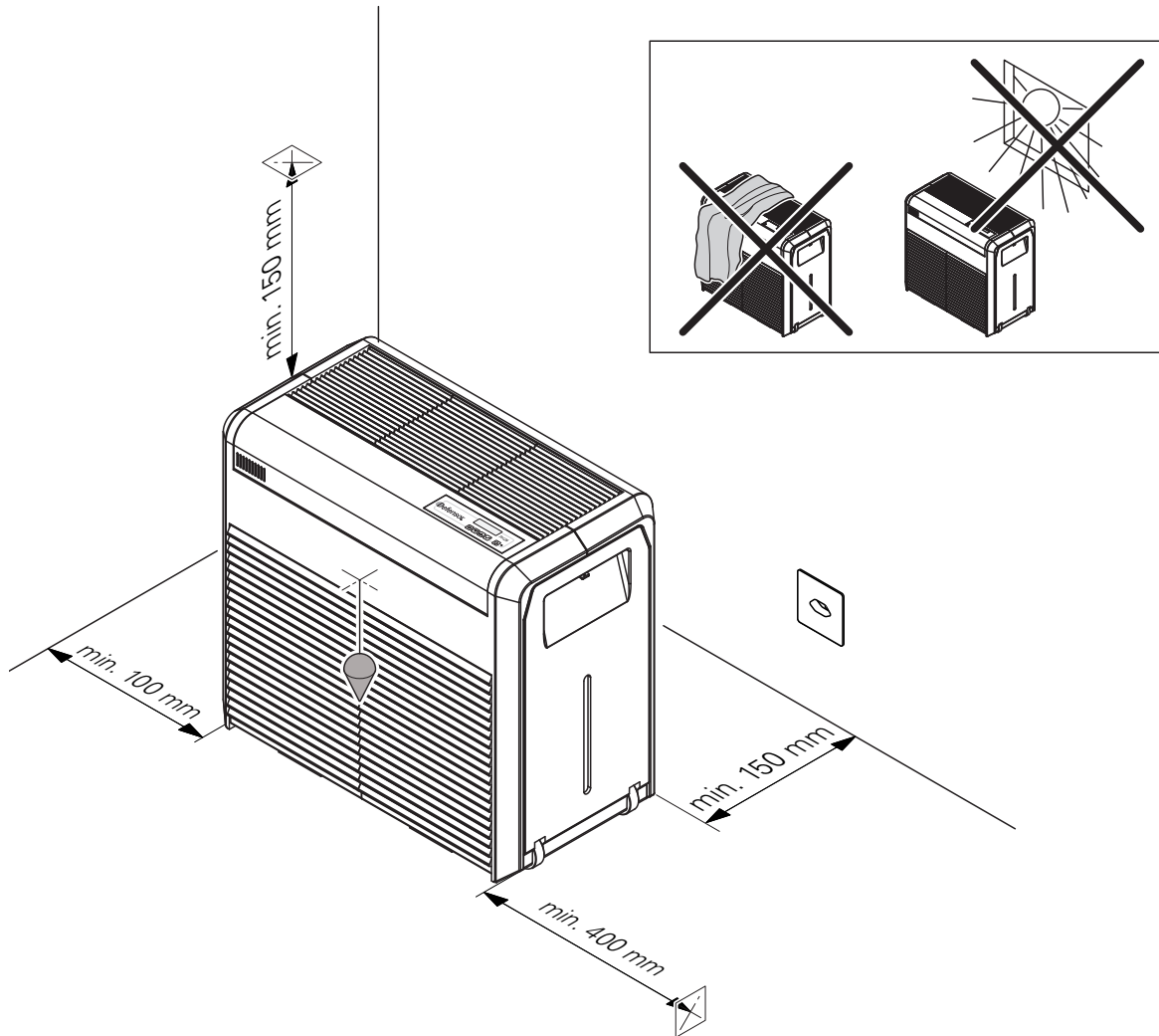

- Place the unit on a solid horizontal surface, if possible free-standing and freely accessible (observe minimal distances).
- A mains socket should be located close to the unit.
- To ensure the entire volume of air is fully recirculated, do not place the unit in recessed compartments, closed corridors, behind curtains, etc.
- Do not place any objects on the unit (performance reduction).
- Continuous direct sunlight is harmful for the unit and can affect the correct function of the integrated humidity sensor. Therefore do not expose the unit to continuous direct sunlight.
- The unit must not be installed in hazardous locations and in rooms where water splashes may occur.

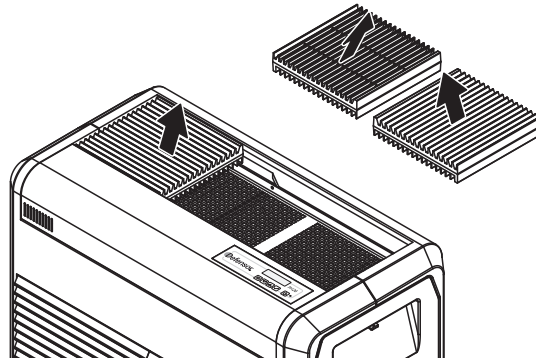

- Install the air outlet grills in a way that the moist air can leave the unit **unhindered** and make sure the air flow is not directed towards obstacles (pillars, furniture, etc.) or cold outer walls (risk of condensation).

4.4 Connecting the water supply (PH28A only)

The water supply has to be connected to the unit by a qualified specialist according to the illustration below. The installation data has to be maintained. The installation of a shut-off valve next to the PH28A is mandatory. Lay the connection hose carefully so that nobody will trip over it.

! WARNING!

For the water installation the unit must be disconnected from the mains (pull the plug out of the socket) and secured against inadvertent reconnection.

Important! The **local regulations** regarding the connection of units to drinking water systems must be observed.

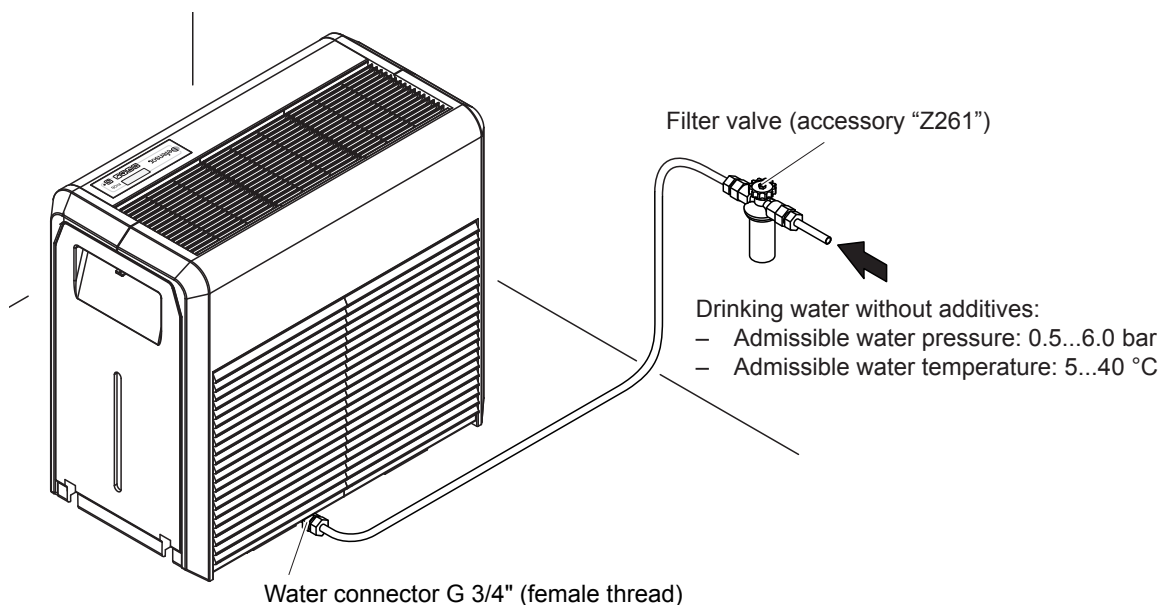

4.5 Putting the unit into operation

Proceed as follows to put the Defensor PH28/PH28A into operation:

- PH28: fill the water tank (see chapter 5.1)
PH28A: open the shut-off valve in the water supply line.
- Connect unit to the mains.

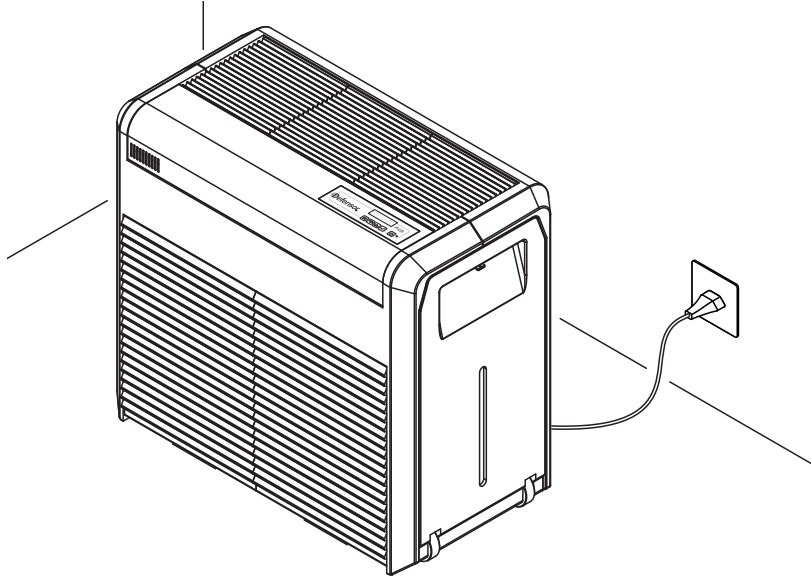

CAUTION!

Make sure the required supply voltage (see type plate) matches the local mains voltage, otherwise do not connect the Defensor PH28/PH28A to the mains!

CAUTION!

The Defensor PH28/PH28A must be **connected only to grounded mains**. Never connect the unit to an outlet without protective earthing.

The Defensor PH28/PH28A is now ready for operation. The next chapter provides detailed information on the operation of the unit.

5 Operation

5.1 Filling the water tank (PH28 only)

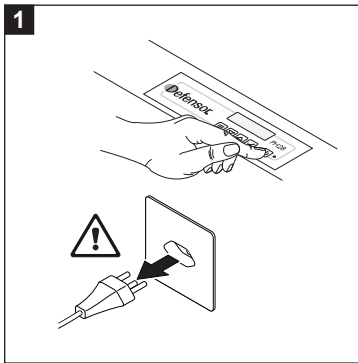

Switch off the Defensor PH28 and disconnect the unit from the mains (pull the mains plug out of the socket).

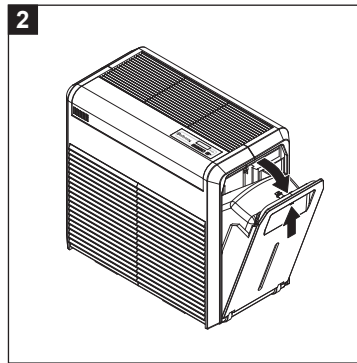

Press the snap and fold out the water tank carriage.

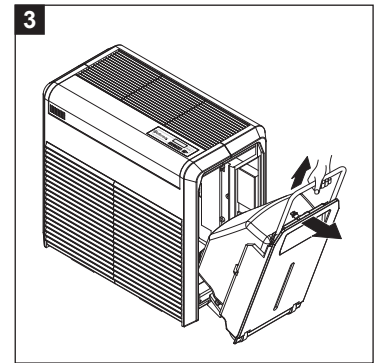

Pull out the handle and slide the water tank carriage out of the unit.
CAUTION! In order to avoid water damage, immediately remove any spilled water on the floor and on the components of the unit.

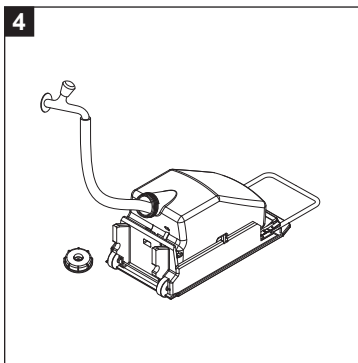

Lay down the water tank carriage, remove the tank cap and fill the tank with tap water using the supplied filling hose. **Do not use additives.** Relocate the tank cap.
Important! Screw on tank cap until it comes to a stop!

CAUTION! In order to avoid water damage, completely remove any spilled water on the water tank carriage.

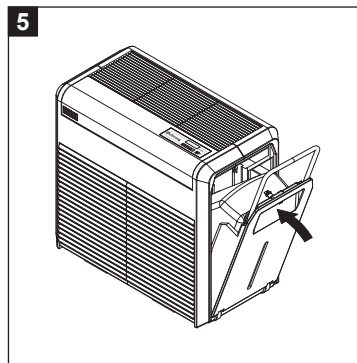

Slide the water tank carriage into the unit, then tip it up to the stop.

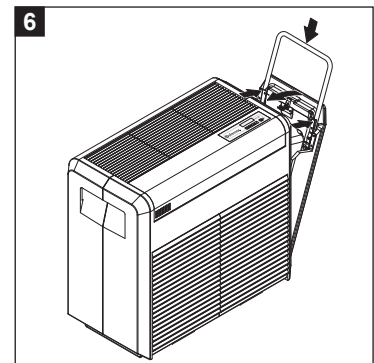

Press the lock mechanism of the handle on both sides of the carriage and the handle slides down. Tip up the water tank carriage until the lock engages. The water now flows into the base tub.
Important! After reinstalling the water tank carriage wait by the unit until the filling sound stops.

5.2 Switching the unit on and off

Switching the unit on

- Press the <On/Off> key.

The unit loads the settings that were active when the device was shut down last. Upon completion the **operating display** appears. The look of the operating display depends whether the Defensor PH28/PH28A is operated in “Normal operating mode” or in “Program mode”.

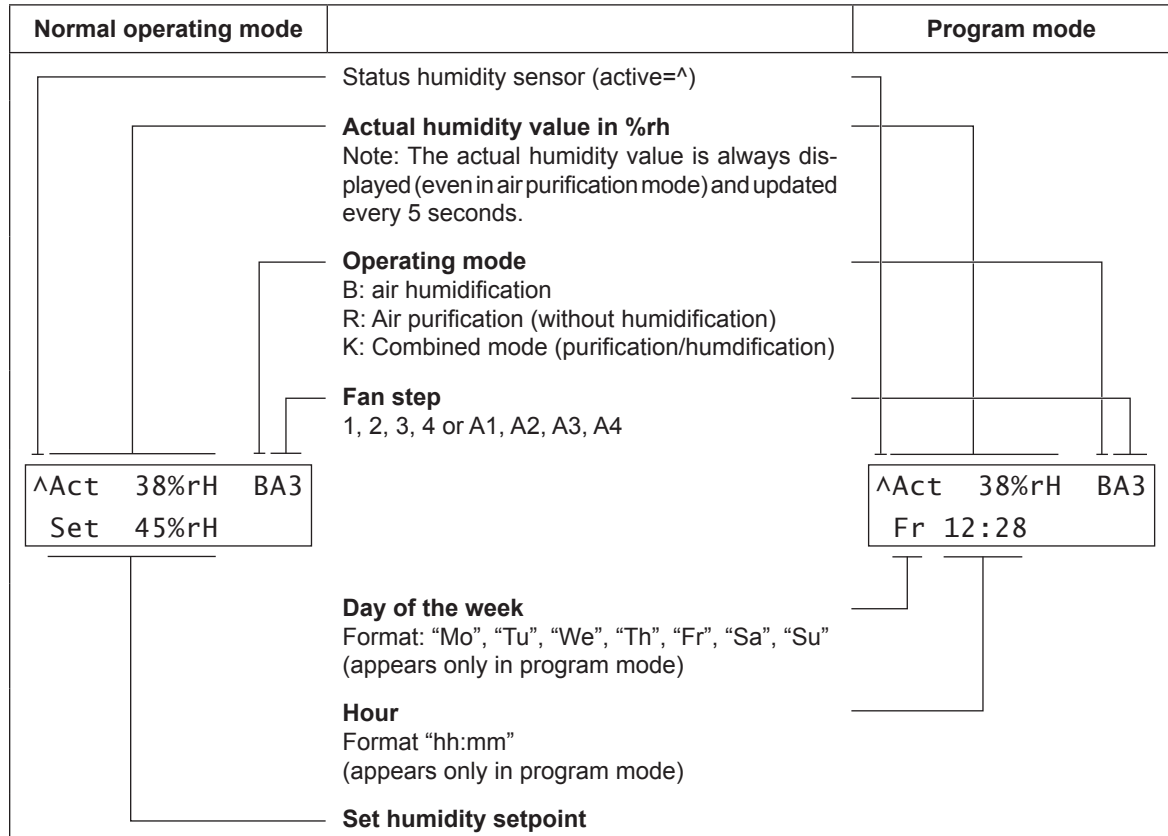

The fan starts in all operating modes with a delay of approx. 1 minute. Until the fan starts the operating mode and the fan step are blinking.

If, after switching on the unit a warning or error message is displayed, please observe the notes in chapter 7.

Switching the unit off

- Press the <On/Off> key.

The currently active settings will be stored upon shutdown.

5.3 Menu overview

The following diagram shows the menu overview of the Defensor PH28/PH28A. After switching on, the unit is in the user level.

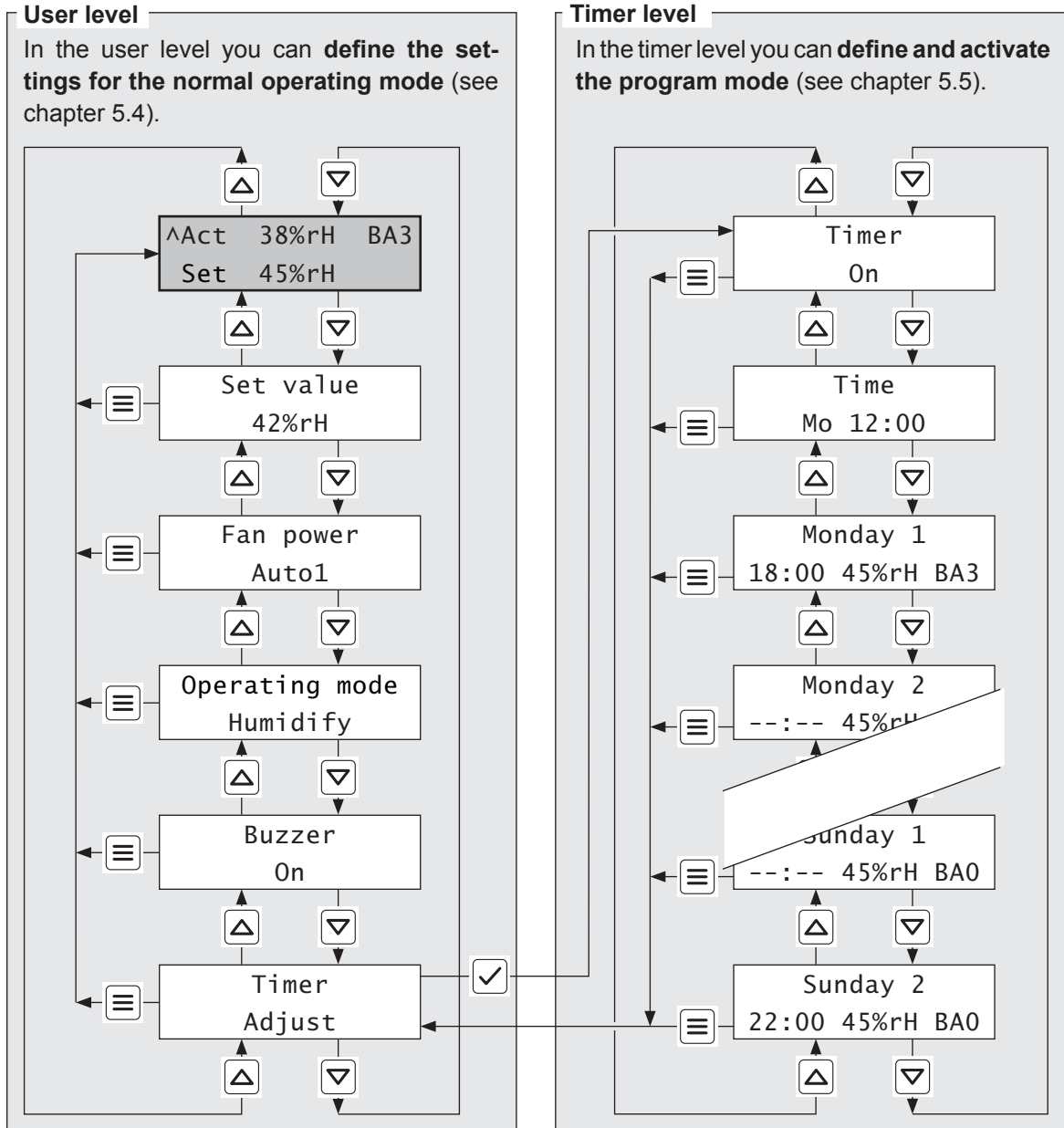

5.4 Unit settings (normal operating mode)

5.4.1 Setting the desired humidity value

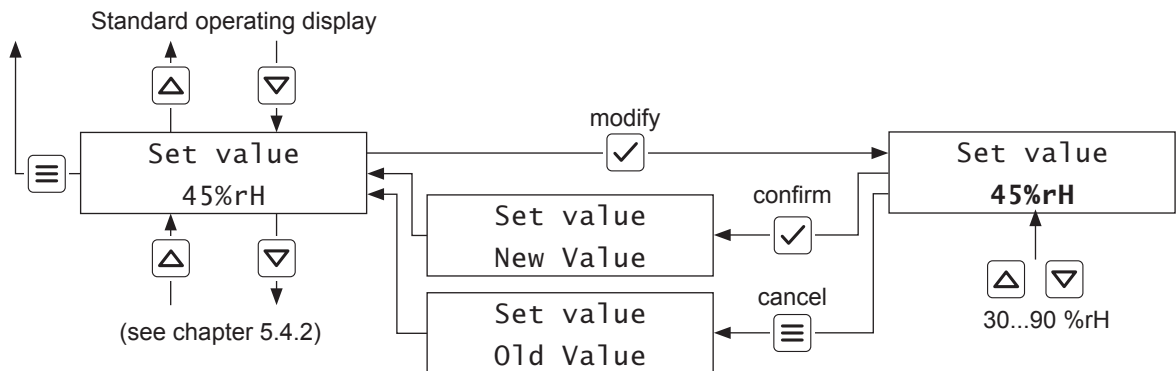

Note: The reference humidity value can be modified only if program mode is deactivated (see chapter 5.5).

Setting range: 30...90 %rH

Factory setting: 45 %rH

Notes on setting: The optimum reference value depends on various factors. For apartments we recommend a value of 40 – 45 %rH.

Note: After initial commissioning or replacement of the vaporizer mat the humidification performance of the Defensor PH28/PH28A will be slightly reduced because the evaporator mat takes a few days to become fully saturated with water. Maximum performance is available after one week, approximately.

Furthermore, the humidification performance depends on the ambient temperature.

5.4.2 Setting the fan step

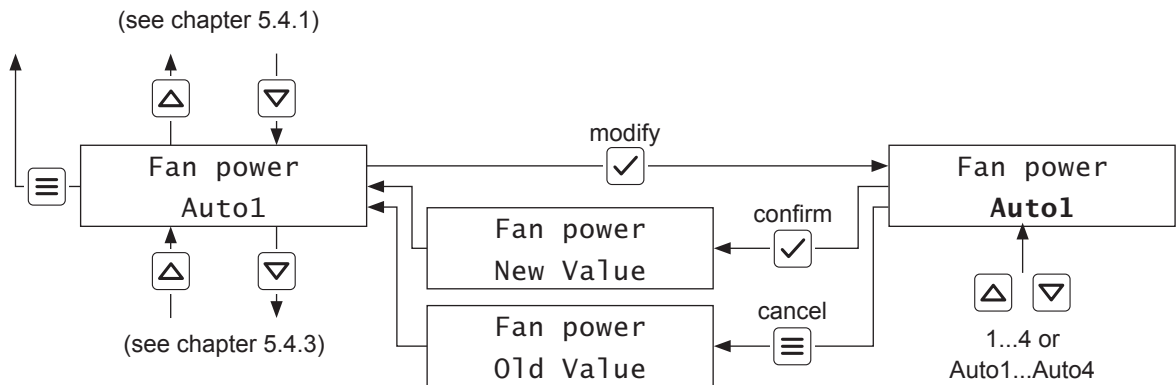

Note: The fan step can be modified only if program mode is deactivated (see chapter 5.5).

Available settings: 1, 2, 3, 4 or Auto1, Auto2, Auto3, Auto4

Operating mode	Fan step	Behaviour
"B" (Humidification)	Auto 1	runs fixed with fan step 1
	Auto 2	automatic switching between fan steps 1..2
	Auto 3	automatic switching between fan steps 1..3
	Auto 4	automatic switching between fan steps 1..4
"R" (Purification) "K" (Combined mode)	1	runs fixed with fan step 1
	2	runs fixed with fan step 2
	3	runs fixed with fan step 3
	4	runs fixed with fan step 4

Factory setting: 1

Notes on setting: The fan step to be selected depends on the operating mode and the size of the room. The table below is meant to assist you in finding the optimum fan step.

Fan step	max. room volume in m ³ for purification (without humidification)				max. room volume in m ³ for humidification
	Air changes per hour				
	1	2	3	4	
1	320	160	110	80	430
2	420	210	140	105	600
3	600	300	200	150	730
4	750	380	250	190	900

The following recirculation cycles per hour are recommended for air purification:

- Normal load: 1 – 2
- heavily polluted air (e.g. pollen, smoke, etc.): 3 – 4

5.4.3 Selecting the operating mode

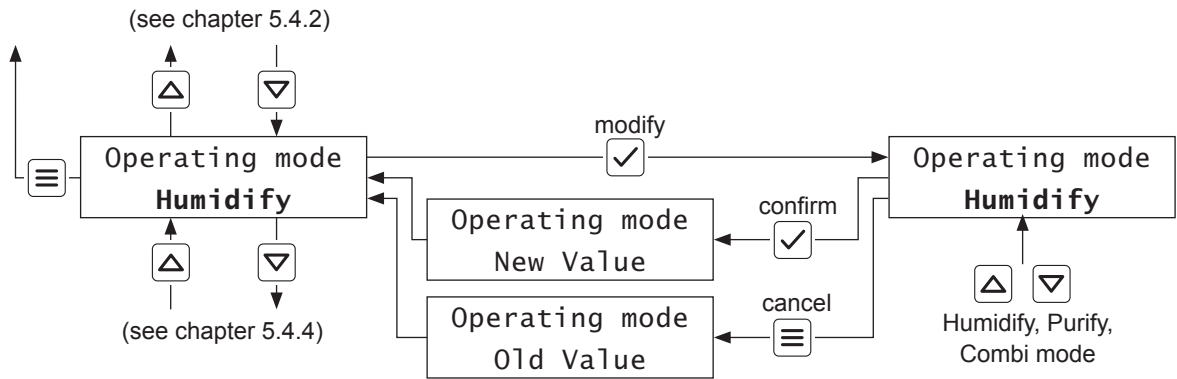

Note: The operating mode can be modified only if program mode is deactivated (see chapter 5.5).

Available settings: Humidify (air humidification), Purify (air purification without humidification) and Combi mode (air purification with humidification)

Factory setting: Humidify

Notes on setting: The selection of the operating mode depends on whether the Defensor PH28/ PH28A shall be operated as humidifier, as purifier without humidification or as purifier with humidification. If the unit shall be operated as purifier without humidification the base tub and the water tank should be emptied.

5.4.4 Switching the buzzer on and off

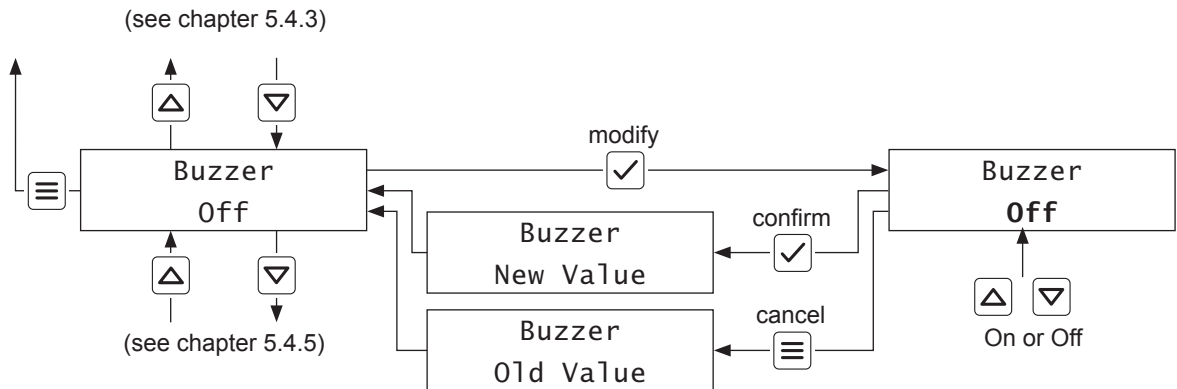

Available settings: On (buzzer on) or Off (buzzer off)

Factory setting: Off

Notes on setting: If the buzzer is on an acoustic signal is triggered in case of a malfunction or an irregularity during operation.

5.4.5 Calling timer level

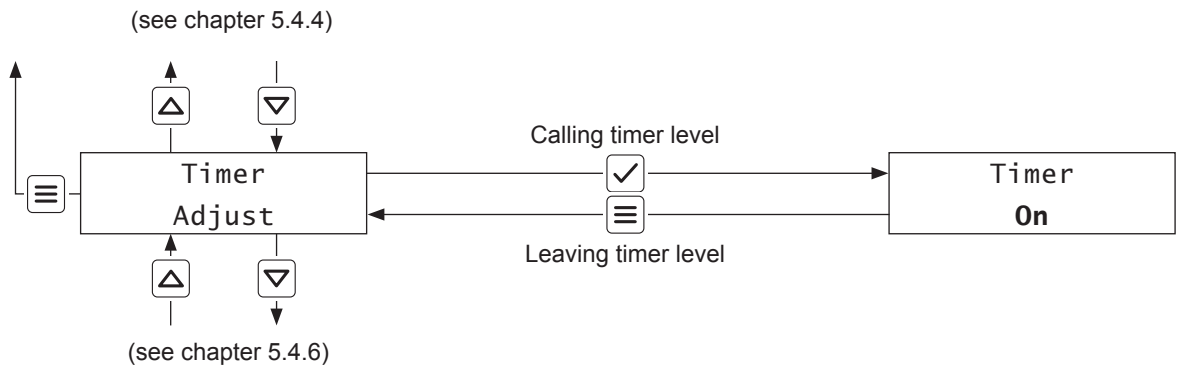

For detailed information regarding the settings in the timer level see chapter 5.5 “program operation”.

5.5 Program operation

The operation of the Defensor PH28/PH28A can be controlled via customisable operating programs. These programs allow to operate the unit at a preset time with the requested operating mode and fan step. This greatly facilitates the adaption of the Defensor PH28/PH28A to your particular requirements (e.g. adjusted to the business hours and/or working time).

Every program consists of a **starting point** (day of the week and hour), a **reference humidity value**, the **operating mode** and the desired **fan step**. **Up to 2 starting points with individual programs may be set up per day**.

In program mode the current program remains active until the following program starts (on the same or on any other day).

Example diagram:

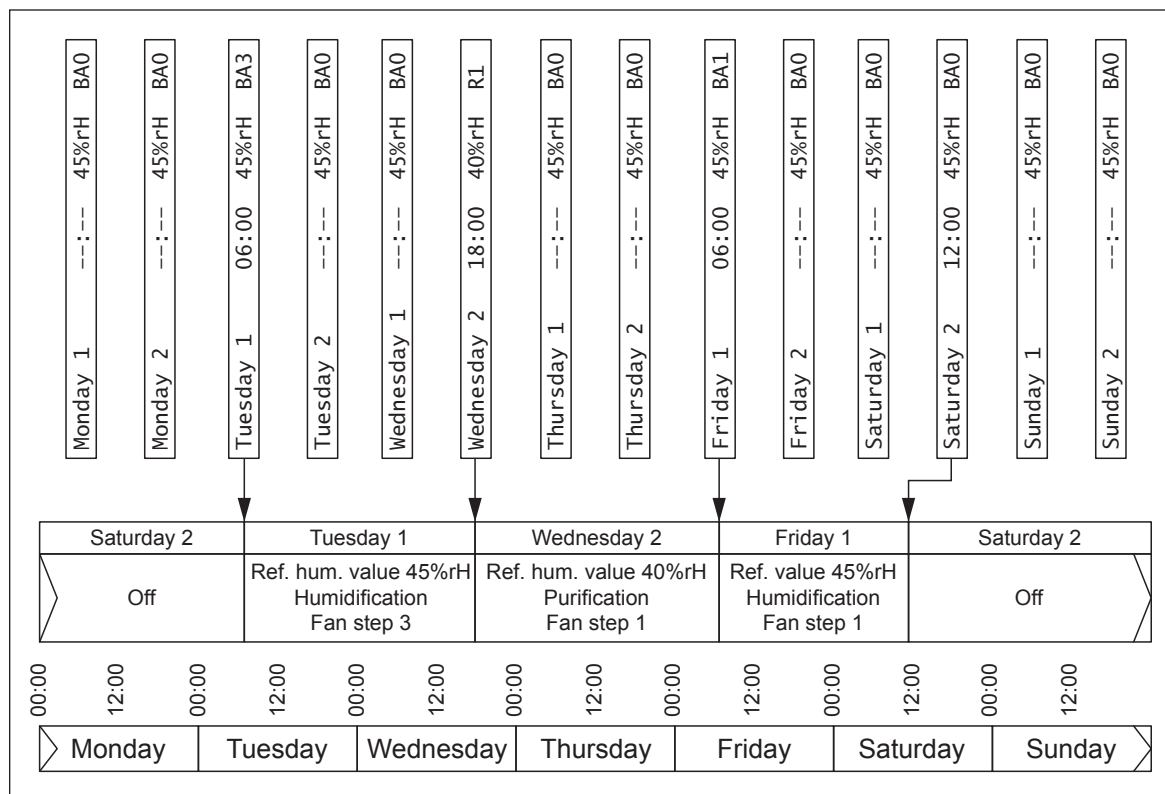

The program settings and the activation of the program mode takes place in the “Timer level”.

5.5.1 Calling the timer level

Within the user level call the timer level (see chapter 5.4.5). In the timer level:

- you can activate and deactivate the program mode (see chapter 5.5.2)
- you can set the day of the week and the hour (see chapter 5.5.3)
- you can define the individual operating programs with their starting points (see chapter 5.5.4)

Note: If no key is pressed in the timer level for a certain time, the unit automatically returns to standard operation.

5.5.2 Activating/Deactivating the program mode

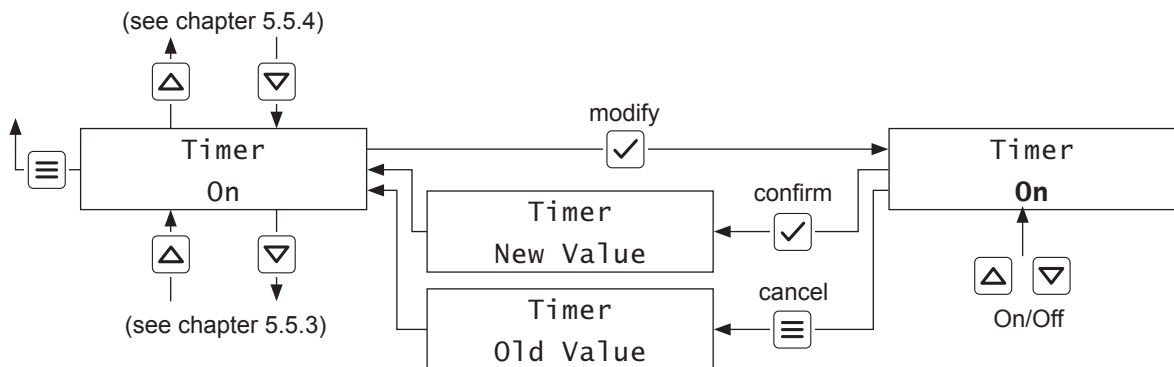

Available settings: On (program mode activated) or Off (program mode deactivated)

Factory setting: Off

Notes on setting: If program mode is activated the Defensor PH28/PH28A operates time-controlled with the operating programs (see chapter 4.3.4). If no programs or starting points are defined the unit operates with the settings of the normal operating mode.

5.4.3 Setting the current time

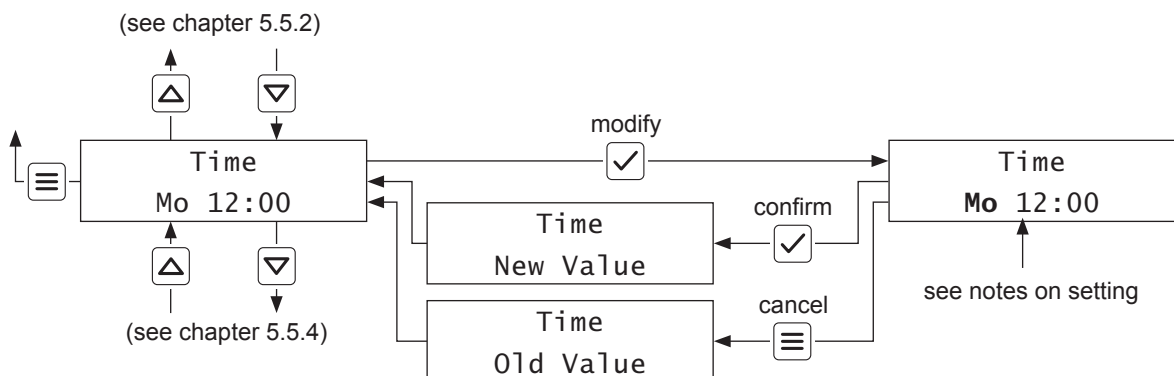

Available settings: Day of the week (Mo, Tu, We, Th, Fr, Sa, Su)
Hour (Format: hh)
Minute (Format: mm)

Factory setting: ---

Notes on setting: The current day of the week and the current time serve as basis for the program mode. If these settings are not set correctly the program timing is wrong.

After calling the modification mode set the current day of the week, the current hour and the current minute. Confirm each setting with the **<Enter>** key.

Note: If the Defensor PH28/PH28A has lost the time settings due to power failure, the time indication (--:--) in the operating display flashes.

5.5.4 Setting the starting points and the operating programs

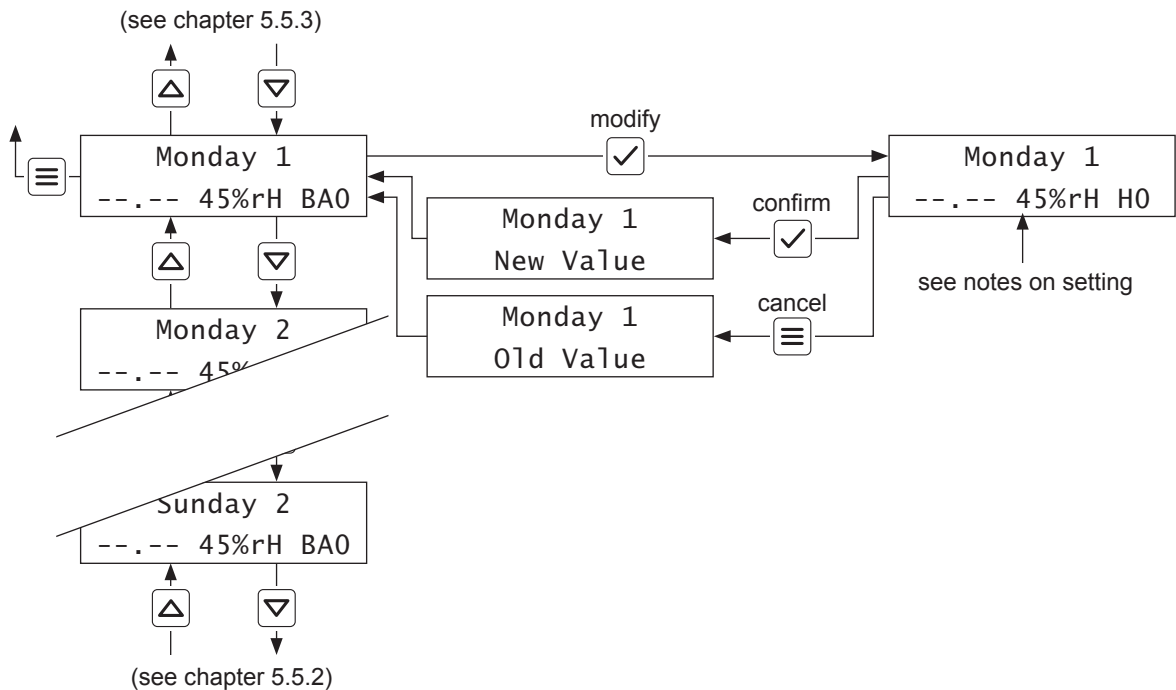

First select the desired day of the week or the starting point, respectively (Monday 1, Monday 2 Sunday 1, Sunday 2), then define the operation settings which should become active at the starting point.

Available settings: Hours (Format: hh)
 Minutes (Format: mm)
 Reference humidity value in %rH
 Operating mode ("B": for humidification, "R": for purification (without humidification) and "K": for combined mode (purification and humidification))
 Fan step (0, 1, 2, 3, 4)

Factory setting: "-- : -- 45%rH BA0"

Notes on setting: After calling the modification mode set the hour, the minute, the reference humidity value, the operating mode and the fan step for the selected starting point. Confirm each setting with the **<Enter>** key.

To deactivate a starting point (display: -- : --) press both arrow keys simultaneously when the hour field flashes. Confirm with the **<Enter>** key. Repeat this procedure with the minute field.

The switch off the unit at a certain time select fan step "0".

5.6 Locking/unlocking the keyboard

The keyboard of the Defensor PH28/PH28A can be locked to prevent unauthorized access to the stored settings.

Key Lock
Set 50%rH

- To lock the keyboard, press **<ESC>** key until (approx. 4 seconds) the adjacent message appears in the display. The keyboard is locked now. Each time you press any key the adjacent message appears again.

Act 30%rH BA3
Set 50%rH

- To unlock the keyboard, press **<ESC>** key until (approx. 4 seconds) the message "Key lock" disappears and the operating display is shown.

6 Maintenance

6.1 Maintenance intervals

The Defensor PH28/PH28A can only provide full humidification and purification performance if the unit is regularly cleaned and the wearing parts are replaced. The maintenance intervals mostly depend on the load of the ambient air, the water quality and the operating time.

Please consider the intervals for cleaning and replacing the individual components in the table below as approximate values. If the room air is heavily contaminated the filters must be cleaned/replaced more often. If the water is very hard the parts in contact with water must be cleaned more often.

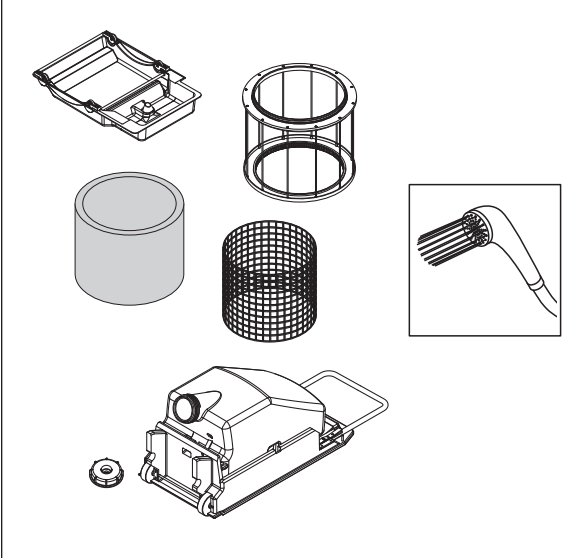
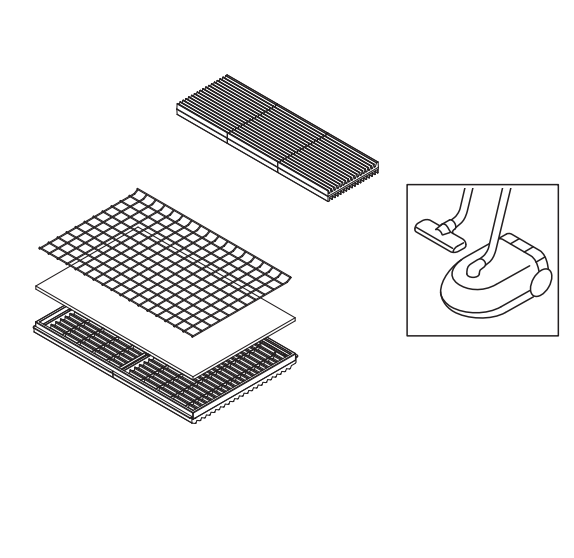
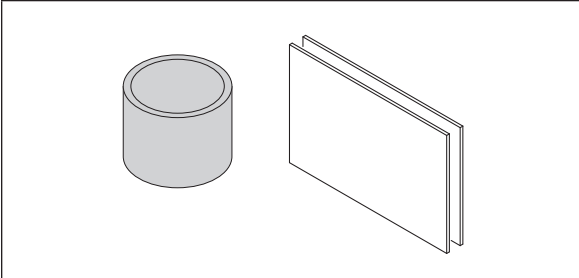
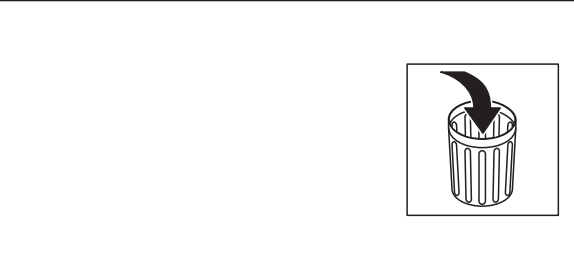
every 2 weeks	
	
<p>As soon as the message Warning 6 Filter change appears or at least every 6 month</p>	
	

Note: If the silver ionisation electrodes are worn, slime will accumulate in the base tub and on the rotary humidification drum. In this case replace the silver ionisation electrodes.

6.2 Maintenance work

6.2.1 Disassembling the unit

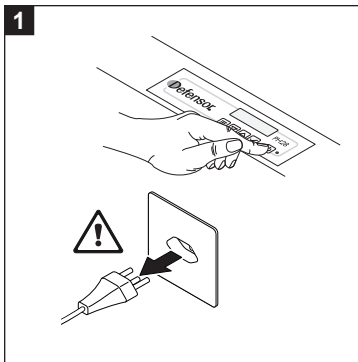

Switch off the Defensor PH28 and disconnect the unit from the mains (pull the mains plug out of the socket). Defensor PH28A only: close the shut-off valve in the water supply line.

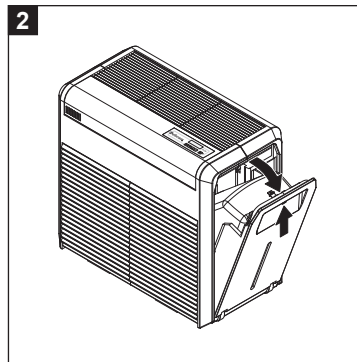

Press the snap and fold out the water tank cart.

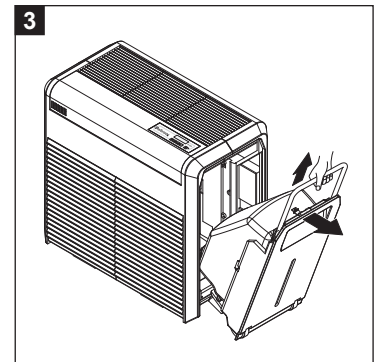

Pull out the handle and slide the cart out of the unit.

CAUTION! In order to avoid water damage, immediately remove any spilled water on the floor and on the components of the unit.

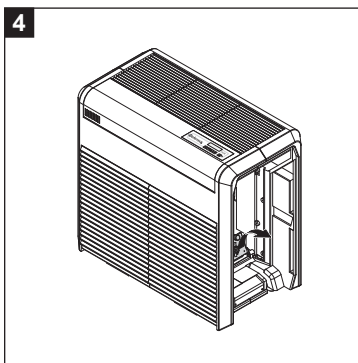

Tip the swivel plate upwards.

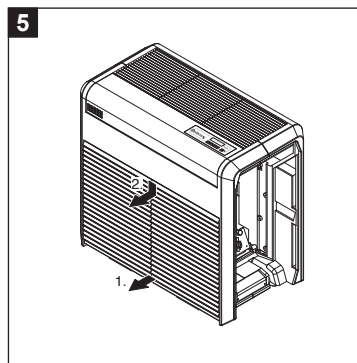

Remove the air intake grills located on both sides of the unit

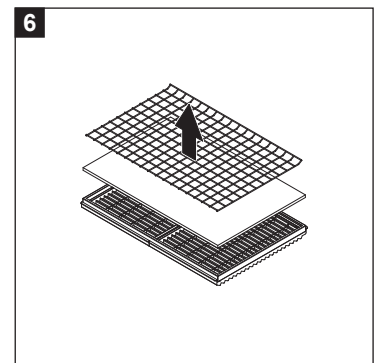

Remove the retainer frame, then take out the filter mat.

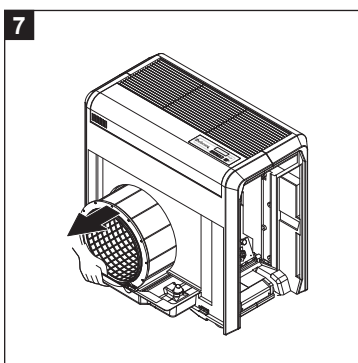

Carefully take out the humidification drum together with the base tub.
CAUTION! In order to avoid water damage, immediately remove any spilled water on the floor and on the components of the unit.

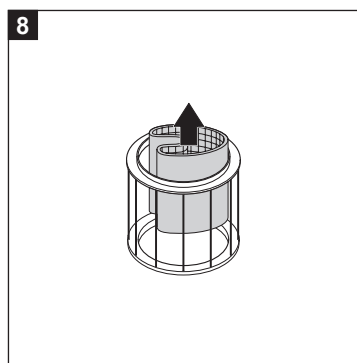

Remove the retaining mesh and the vaporizer mat from the humidification drum (observe the illustration).

6.2.2 Cleaning work

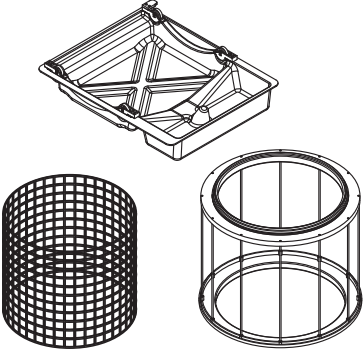
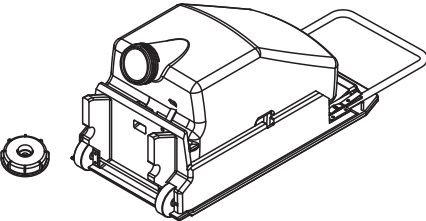
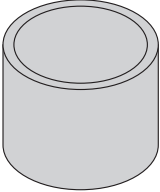
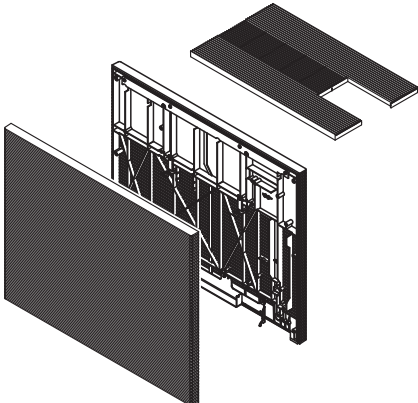
Unit component	What to clean and how to clean
<p data-bbox="292 324 644 387">Base tub, Retaining net, Rotary humidification drum</p> 	<ul data-bbox="751 324 1431 504" style="list-style-type: none"> • Wash parts with a lukewarm soap solution and rinse well with tap water. • Occasionally remove scale coating with a household decalcify agent (observe safety notes in chapter 6.3). Finally rinse the parts well with tap water.
<p data-bbox="292 788 432 815">Water tank</p> 	<ul data-bbox="751 788 1431 929" style="list-style-type: none"> • Flush water tank with a lukewarm soap solution and rinse well with tap water. • Wash screw cap with a lukewarm soap solution and rinse well with tap water. <p data-bbox="783 936 1431 1037">Occasionally remove scale coating with a household decalcify agent (observe safety notes in chapter 6.3). Finally rinse the screw cap well with tap water.</p>
<p data-bbox="292 1115 491 1142">Evaporator mat</p> 	<ul data-bbox="751 1115 1431 1178" style="list-style-type: none"> • Rinse the evaporator mat thoroughly with lukewarm water without any additives. <p data-bbox="783 1184 1431 1317">Note: As soon as the filter replacing message appears in the display (see error messages in chapter 7) replace the evaporator mat together with the coarse dust filters (Quattro filters).</p>
<p data-bbox="292 1406 663 1433">Air intake and air outlet grills</p> 	<ul data-bbox="751 1406 1431 1469" style="list-style-type: none"> • Clean the air intake and air outlet grills on both sides with a vacuum cleaner.

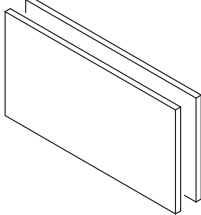
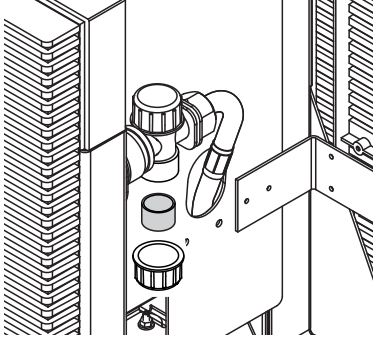
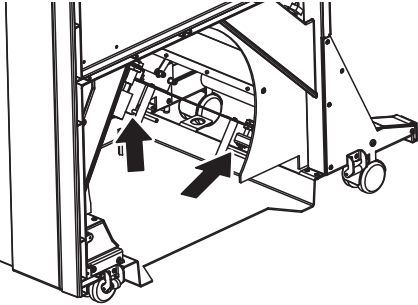
Unit component	What to clean and how to clean
<p data-bbox="292 248 718 282">Coarse dust filters (Quattro filters)</p> 	<ul data-bbox="751 248 1433 454" style="list-style-type: none"> • Clean the coarse dust filters (Quattro filters) on the inner side with a vacuum cleaner (lowest power step). Note: As soon as the filter replacing message appears in the display (see error messages in chapter 7) replace coarse dust filters (Quattro filters) together with the evaporator mat evaporator mat. <p data-bbox="751 472 1433 533">CAUTION! Make sure the filters do not get wet. Wet filters must be dry before reinstalling.</p>
<p data-bbox="292 555 459 618">Water filter (PH28A only)</p> 	<ul data-bbox="751 555 1433 651" style="list-style-type: none"> • Unmount and check water filter. If necessary clean water filter with a brush, then rinse filter well with tap water. Remount water filter.
<p data-bbox="292 1019 643 1115">Level switch Safety switch Silver ionisation electrodes</p> 	<ul data-bbox="751 1019 1433 1079" style="list-style-type: none"> • Carefully wipe the level switch , the safety switch and the silver ionisation electrodes with a damp cloth.

6.3 Notes on cleaning agent

Only use cleaning agents stated in the table above. The use of disinfectants is only permitted if they do not leave any toxic residues. In any case the parts must be thoroughly rinsed with water after cleaning.

DANGER!

Household decalcify agent attacks the mucous membranes and the skin. Protect the hands, eyes and respiratory tracts therefore from contact with the agent and its vapour (wear gloves, goggles and work in a well ventilated room or outside).

CAUTION!

Do not use any solvents, aromatised or halogenised hydrocarbons or other aggressive substances, they may damage the unit components.

The information and instructions regarding cleaning agents are to be unconditionally observed and implemented. In particular: Information relating to the protection of personnel, environmental conservation and restrictions regarding usage.

6.4 Reassembly of the unit

CAUTION!

Before reassembling the Defensor PH28 check all components for possible damage. Do not reuse damaged parts but replace them before reassembling the unit

Reassemble the unit as follows:

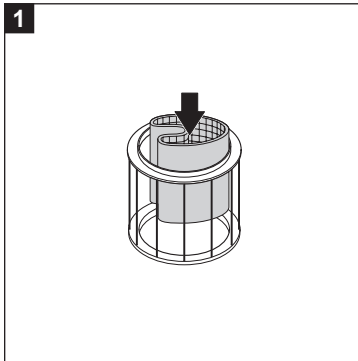

Install the vaporizer mat and the retaining mesh in the humidification drum.

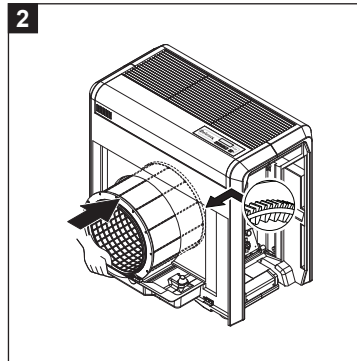

Slide the humidification drum (with the internal geared wheel facing backwards) together with the base tub into the unit.

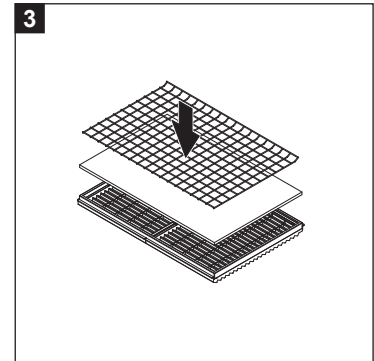

Place the **coarse dust filter with the blue side facing upwards** (facing to the centre when mounted) or the **Quattro filter with the fluffy side facing the bottom** (facing outwards when mounted) in the air intake grills, then mount the retainer frame.

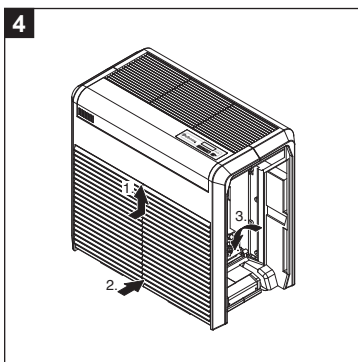

Mount the air intake grill, then tip the swivel plate down.

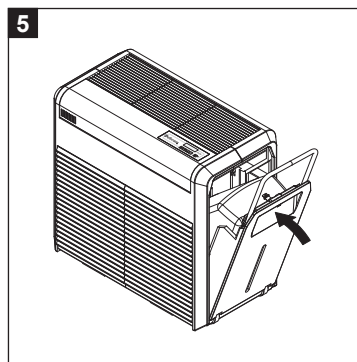

Slide the water tank cart into the unit.

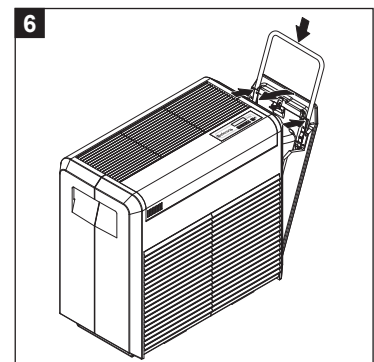

Press the lock mechanism of the handle on both sides of the cart (the handle slides down), then tip up the cart until the lock engages.
Important! After reinstalling the water tank wait by the unit until the filling sound stops.

6.5 Resetting the filter changing message

After the replacement of the filters and the evaporator mat the filter changing message can be reset as follows:

Warning 6 Filter change

Filter change	ESC	OK
---------------	-----	----

1. Switch on the unit (the filter changing message appears).
2. Press the **<ESC>** and **<Enter>** keys simultaneously until the opposite message appears.
3. Press the **<Enter>** key to reset the filter changing message and the interval counter. The standard operating display appears.
Note: By pressing the **<ESC>** key the reset procedure can be cancelled without action. The filter changing message is then displayed again.

6.6 Repair work

Note: Except for the change of the fuse and the replacement of damaged parts revealed upon maintenance, the **customer must not carry out any repair work.**

Replacement of the unit fuse

1. Shut down the Defensor PH28 and disconnect the unit from the mains (pull the mains plug out of the socket).
2. Remove the water tank carriage (see chapter 5.1).
3. Loosen the screws of the terminal cover, then remove the cover.

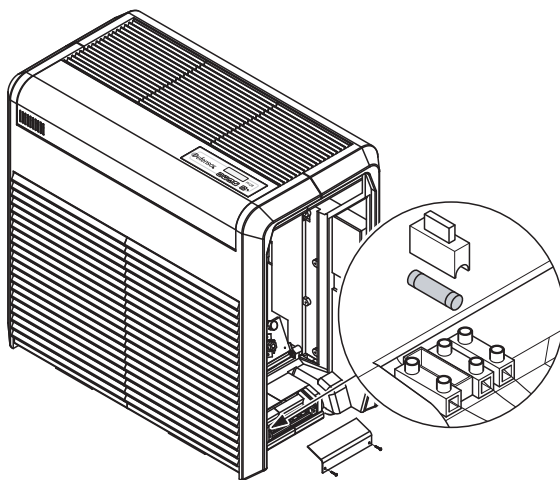

4. Pull out the fuse holder.
5. Replace the fuse.
Make sure the data of the new fuse are in accordance with the following specifications:
 - Units for 200...240V/50...60Hz mains:
fuse type 1.25A, slow-blow
 - Units for 110...120V/50...60Hz mains:
fuse type 2.5A, slow-blow

The operating voltage is specified on the type plate located inside the unit.

⚠ DANGER!

Never use fuses that do not match the above specifications and do not bypass blown fuses as this could rise danger to persons or material assets

6. Reinstall the fuse holder, then press the holder down until it properly engages.
7. Mount the terminal cover and tighten both mounting screws.
8. Insert and lock the water tank carriage (see chapter 5.1).
9. Reconnect the unit to the mains.

Replacing the ionizer electrodes

1. Shut down the Defensor PH28 and disconnect the unit from the mains (pull the mains plug out of the socket).
2. Remove the water tank carriage (see chapter 5.1) and tip the swivel plate up.
3. Replace the ionizer electrodes according to the opposite figure.

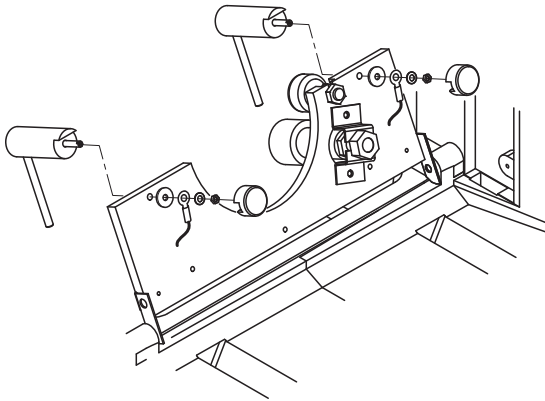

4. Tip the swivel plate down.
5. Insert and lock the water tank carriage (see chapter 5.1).
6. Reconnect the unit to the mains.

7 Fault elimination

7.1 Event messages

Display	Description
Radio sensor K1 Install.? ESC/E	<p>Cause: If a new battery is inserted into the radio humidity sensor (option) and the radio channel of the radio humidity sensor does not correspond to the active channel of the Defensor PH28/PH28A a beep sounds briefly (if the buzzer is activated) and a new radio channel (e.g. K1) will be proposed.</p> <p>Action: Press the <Enter> key if you want to confirm the suggested channel. The Defensor PH28/PH28A switches to the new channel and returns to the standard operating display. Press the <ESC> key if you want to reject the suggested channel. The Defensor PH28/PH28A returns to the standard operating display and uses the old signal source.</p>
Radio sensor K1 Test	<p>Cause: If a new battery is inserted into the radio humidity sensor (option) and the radio channel of the radio humidity sensor does correspond to the active channel of the Defensor PH28/PH28A a beep sounds briefly (if the buzzer is activated) and the unit confirms the correct channel.</p> <p>Action: To reset the message and to return to the standard operating display press the <Enter> or the <ESC> key.</p>

7.2 Warning messages

Display	red LED	Buzzer	Error relay	Resetting
Warning 6 Filter change Warning message is alternating with the standard operating display.	lights	—	activated	see chapter 6.5.
<p>Cause: Maximum lifetime of the filter set expired.</p> <p>Action/Remedy: Replace filter set (see chapter 6 "Maintenance"), then reset warning message.</p>				
Warning 7 No water Warning message is displayed until the water level in the base tub is ok. again.	lights	—	activated	Automatic resetting as soon as the water level in the base tub is at normal level again.
<p>Note: This message is displayed only on the Defensor PH28</p> <p>Cause: The water level in the base tub is too low, level switch has triggered.</p> <p>Action/Remedy: Check/refill water tank.</p>				
Warning 8 Battery radio Warning message is alternating with the standard operating display.	lights	beeps briefly every 30 minutes	activated	Automatic resetting after replacement of the battery.
<p>Cause: Battery in radio humidity sensor (option) is empty.</p> <p>Action/Remedy: Replace battery of the radio humidity sensor (see separate instructions of radio humidity sensor).</p>				

7.3 Error messages

Display	red LED	Buzzer	Error relay	Resetting
<div style="border: 1px solid black; padding: 5px; text-align: center;"> Error 1 Cover open </div> <p>Error message is displayed until the water tank carriage (PH28) or the side cover (PH28A) is inserted correctly and locked.</p>	flashes	—	activated	Automatic resetting as soon as the water tank carriage (PH28) or the side cover (PH28A) is inserted correctly and locked.
<p>Cause: Water tank carriage (PH28) or side cover (PH28A) not inserted and locked. Action/Remedy: Correctly insert water tank carriage (PH28) or side cover (PH28A) and lock it.</p>				
<div style="border: 1px solid black; padding: 5px; text-align: center;"> Error 2 Max Niveau </div> <p>Error message is displayed until reset.</p>	flashes	buzzes loudly (can not be switched off)	activated	Switch unit off, then on again.
<p>Cause: Maximum water level in the base tub exceeded. Safety switch has triggered. PH28: water tank not tight (tank cap not tight and/or level regulating valve in the tank cap blocked or defective). PH28A: inlet valve defective. Action/Remedy: PH28: Remove the tank immediately. Check/clean filler neck, tank cap and level regulating valve in tank cap (replace tank cap if necessary), then close tank cap correctly. PH28A: check/replace inlet valve.</p>				
<div style="border: 1px solid black; padding: 5px; text-align: center;"> Error 3 Filltime </div> <p>Error message is displayed until reset.</p>	flashes	buzzes	activated	Switch unit off, then on again.
<p>Note: This message is displayed only on the Defensor PH28A Cause: Shut-off valve in the water supply line closed. Internal water filter (near to the inlet valve) blocked. Inlet valve defective. Action/Remedy: open shut-off valve in the water supply line. Clean water filter (see chapter 6.3). Check/replace inlet valve.</p>				
<div style="border: 1px solid black; padding: 5px; text-align: center;"> Error 4 No signal </div> <p>Error message is alternating with the standard operating display.</p>	flashes	beeps briefly every 6 minutes	activated	Automatic resetting as soon as the unit receives a signal from the radio humidity sensor.
<p>Cause: The Defensor PH28/PH28A does not receive any signal from the radio humidity sensor (option). Battery of the radio humidity sensor soon empty or radio humidity sensor defective. Radio humidity sensor installed outside the signal range of 25 m. Note: As long as the unit does not receive any signal from the radio humidity sensor it switches to the internal humidity sensor. Action/Remedy: Replace the battery of the radio humidity sensor. Check/replace radio humidity sensor. Install radio humidity sensor inside the signal range.</p>				

7.4 What, if...?

The following table lists symptoms of malfunction that may occur in daily operation of the Defensor PH28/PH28A, together with possible causes and suggested remedies.

Symptom	Cause	Remedy
Unit does not work, LC display remains dark	Unit is not connected to the mains.	Connect unit to the mains.
	Unit fuse blown.	Have a service technician of your Defensor supplier check the unit.
Unit does not humidify.	Humidifier drum does not turn. Humidifier drum not correctly installed.	Correctly install humidifier drum. Gear wheel of the humidifier drum must engage in the driving gear wheel.
	Ambient air humidity is higher than selected reference value.	No remedy required, change reference humidity value if necessary.
	Level switch is defective. Therefore no error message is displayed even though the water level in the base tub is too low.	Have a service technician of your Defensor supplier replace the level switch
Room air does not reach the set reference humidity value.	Evaporator mat not installed.	Install evaporator mat.
	Room temperature too high.	Reduce room temperature to 20-22°C.
	Unit very dirty.	Perform maintenance (see chapter 6)
	Doors or windows are open.	Close doors and windows.
	Prolonged ventilation of the room. Therefore continuous replacement of the humidified room air by dry outdoor air.	Ventilate room only a short time!
	Room too large.	Contact your Defensor supplier.
Actual humidity much higher than the reference value.	The actual humidity is higher than the set reference air humidity.	Let unit running as air purifier.
Fan does not run	Humidification mode "Humidification" selected. Ambient humidity is higher than selected reference value.	None. Unit is working properly.
	Unit is in program mode. The currently active program sets the fan step to "0".	None. Unit is working properly.
	Fan defective.	Contact your Defensor supplier.
Base tub and rotary humidification drum have heavy slime accumulation.	Silver coating on the water ionisation electrodes is worn.	Have a service technician of your Defensor supplier replace the water ionisation electrodes.

7.5 Notes on fault elimination

 **DANGER!**

For the elimination of faults **set the Defensor PH28/PH28A out of operation, separate the unit from the mains and secure it against inadvertent power-up.**

The elimination of faults must be carried out only by qualified and well trained professionals. Malfunctions relating to the electrical installation must only be repaired by authorized personnel or by your Defensor representative's service technician.

Repair work and the replacement of faulty components must be carried out only by your Defensor representative's service technician!

8 Taking out of service/Disposal

8.1 Taking out of service

If the Defensor PH28/PH28A must be replaced or if the unit is not needed any more, proceed as follows:

1. Switch off the unit, separate it from the mains and secure it against inadvertent power-up. Close shut-off valve in the water supply line (PH28A only).
2. Have the unit (and all other system components, if necessary) unmounted by a qualified service technician.

8.2 Disposal/Recycling

At the end of the life-span the unit and its components must be returned to the manufacturer or brought to an authorised collection point for correct disposal and/or recycling according to the local regulations.

In case of doubt please contact your local administration or your Defensor supplier.

9 Unit specifications

Dimensions (B x H x T)	800 x 750 x 440 mm			
Weight (empty)	43 kg			
Operating weight	73 kg			
Water tank capacity	30 l			
Mains voltage	220...240VAC/50...60Hz oder 90...110VAC/50...60Hz			
Power consumption	max. 128 W			
Capacity levels ¹⁾	1	2	3	4
Air circulation rate	320 m ³ /h	420 m ³ /h	600 m ³ /h	750 m ³ /h
Humidification capacity (at 25 °C and 20 %rh)	1.7 l/h	2.1 l/h	2.4 l/h	2.7 l/h
Humidification capacity (at 23 °C and 45 %rh)	0.9 l/h	1.2 l/h	1.4 l/h	1.6 l/h
For rooms up to a max. of	430 m ³	600 m ³	730 m ³	900 m ³
Sound pressure level	40 dBA	48 dBA	54 dBA	58 dBA
Sound power level (according EN ISO 3741)	54 dBA	62 dBA	68 dBA	72 dBA
Admissible ambient temperature	5...40 °C			
Admissible ambient humidity	0...85 %rh non condensing			
Unit version PH28A				
– Water supply connector	G 3/4" (female connector)			
– Admissible water pressure	0.5...6.0 bar			
– Admissible water temperature	5...40 °C			
Certificates	VDE, GS, CE, GOST			

¹⁾ The performance data are based on a unit with basic equipment for humidifier operation

10 Appendix

10.1 Wiring diagram

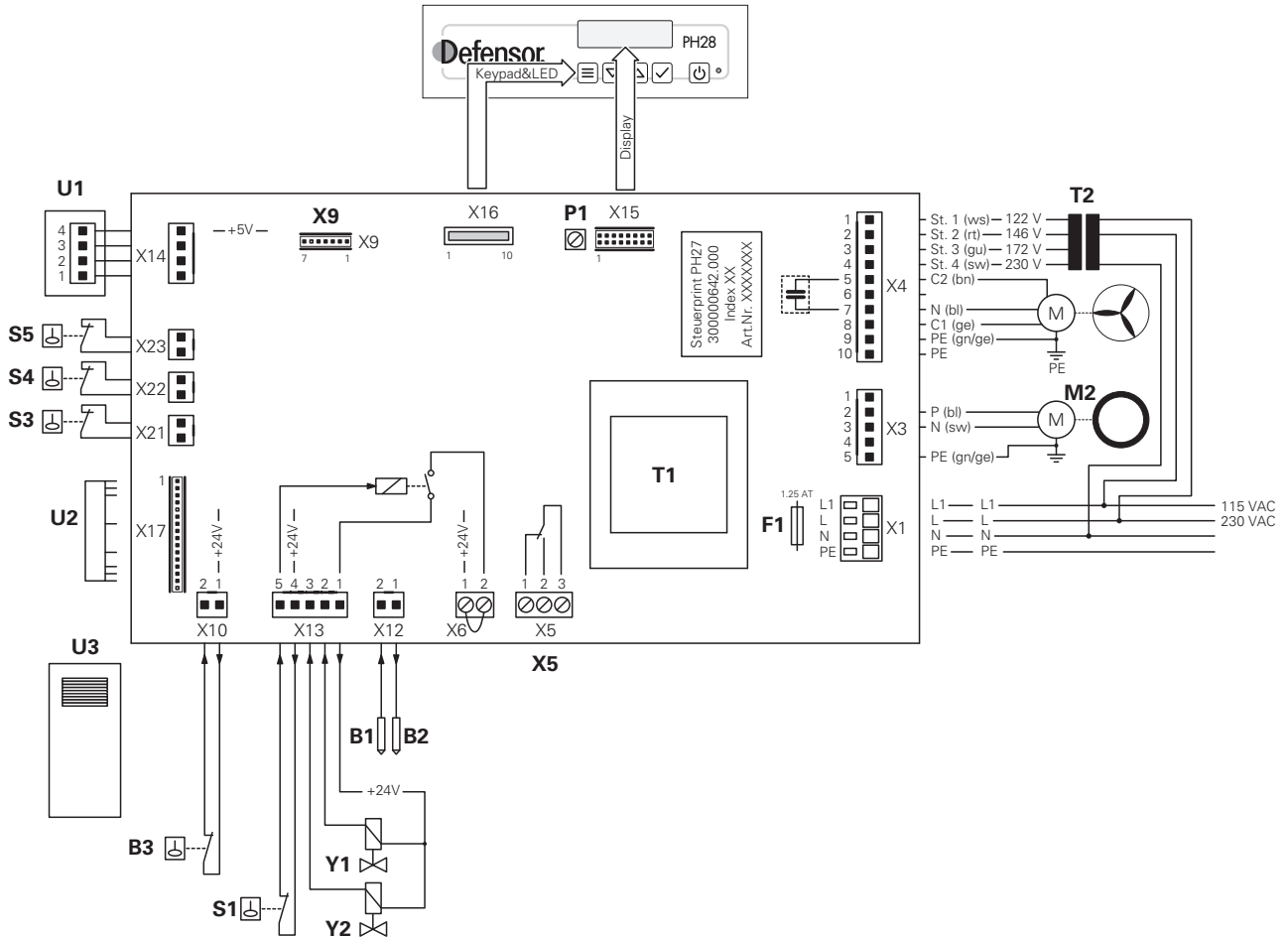

B1/B2	Ionisation electrodes	U1	Internal humidity sensor
B3	Level switch	U2	Radio receiver (option)
F1	Fuse control board (1.25 A, slow acting)	U3	External radio humidity sensor (option)
M1	4-step fan	T1	Transformer control board
M2	Drum motor	T2	Transformer fan
P1	Potentiometer display contrast	X5	Error contact, max. 250 VAC
S1	Safety switch	X9	Programming interface
S3	Micro switch side cover	Y1	Inlet valve (PH28A only)
S4	Micro switch air intake grill 1	Y2	Inlet safety valve (PH28A only)
S5	Micro switch air intake grill 2		

10.2 Spare parts list PH28

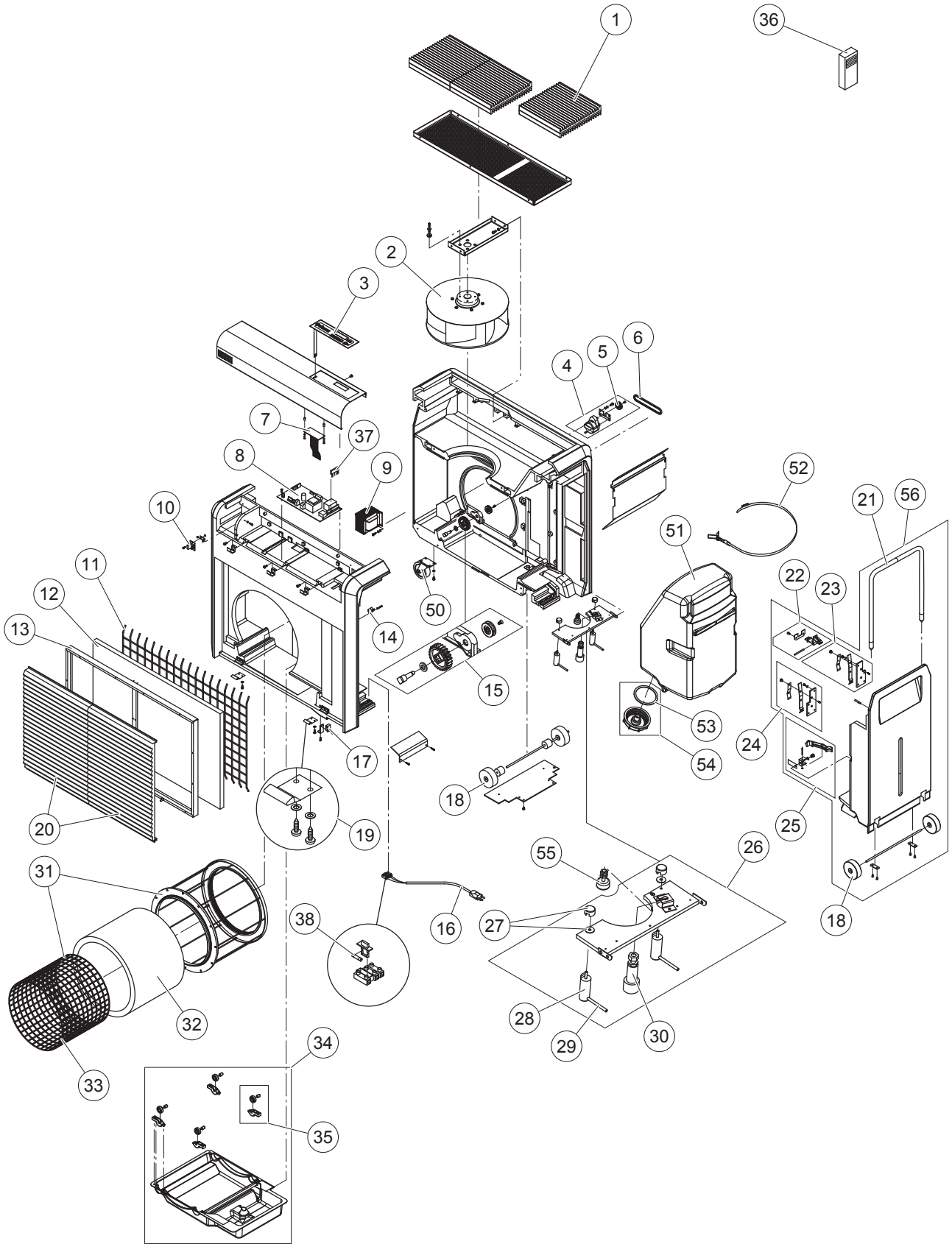

Pos.	Art.-No.	Spare parts designation
1	2560541	Outlet grill
	2561710	Outlet grill special color (RAL or NCS code according type plate)
2	1109392	Fan cpl.
3	2560927	Keyboard foil
4	2560916	Synchronous motor cpl.
5	2533163	Tothed belt pulley for motor
6	1103725	Toothed belt
7	1115515	Display LCD
8	2560896	Control PCB
9	1103722	Transformer cpl.
10	1103719	Humidity sensor cpl.
11	1103936	Support Mesh
12	1106228	Z85 Coarse dust filter (2 pcs)
	1109907	Z26 Quattro filter (2 pcs)
13	1103286	Filter frame
14	1110666	Microswitch door lock
15	1102217	Drive wheel cpl.
16	1100034	Mains lead CH
	1110153	Mains lead EU
	1116469	Mains lead Singapore
17	1103714	Microswitch filter wall
18	2560893	Roller (2 pcs)
19	1103737	Retainer spring cpl.
20	1114709	Air Intake grill (2 pcs)
	2561711	Air Intake grill special color (2 pcs) (RAL or NCS code according type plate)
21	2560889	Handle
22	1102394	Door locking set
23	2560883	Stop lever cpl. (left)
24	2560884	Stop lever cpl. (right)
25	1103732	Door arresting set
26	2560917	Hinged plate cpl.
27	2524412	Insulation cap + socket (2 pcs)
28	2525859	Support ionisation electrode cpl. (2 pcs)
29	1115356	Ionisation electrode (2 pcs)
30	2560898	Level switch
31	1110529	Humidification drum
32	1100465	Z87 Evaporator mat neutral
	1110398	Z57 AC-evaporator mat
33	2560894	Retaining net
34	1109953	Base tub cpl.
35	1101326	Bearings and rollers (4 pcs)
36	2524759	Radio humidity sensor
37	2525353	Receiver module
38	1102957	Fuse 5x20 1.25A T (3 pcs)
	2560932	Fuse 5x20 2.5A T (3 pcs)
---	1119520	Ionisation cable
50	2560888	Caster
51	1101592	Water tank
52	2560885	Tightener
53	1110179	Gasket level control valve $\varnothing 84$
54	1104407	Level control valve
55	2560897	Level safety switch
56	1117040	Water tank carriage
	2561712	Water tank carriage special color (RAL or NCS code according type plate)
---	1115357	Filling hose

10.3 Spare parts list PH28A

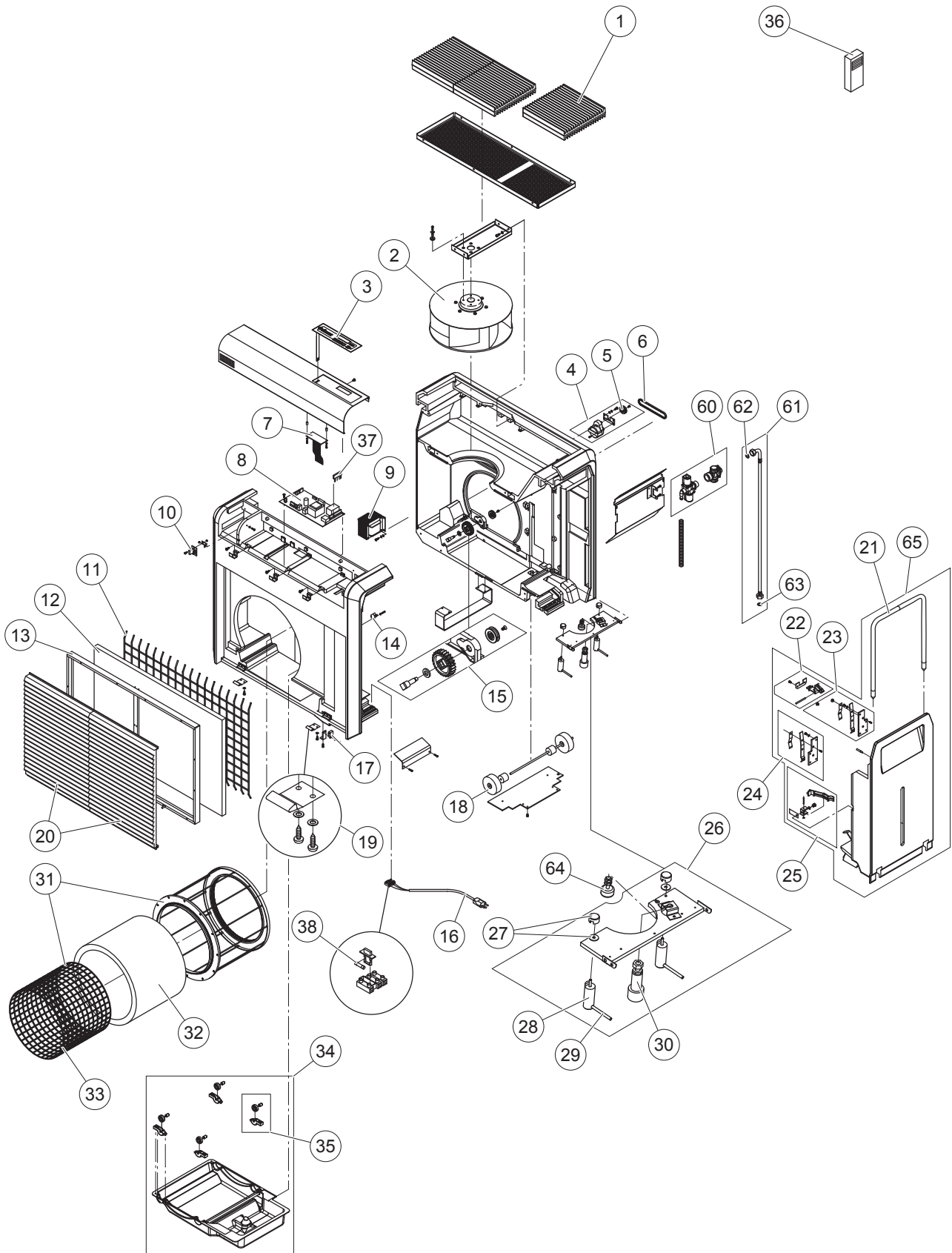

Pos.	Art.-No.	Spare parts designation
1	2560541	Outlet grill
	2561710	Outlet grill special color (RAL or NCS code according type plate)
2	1109392	Fan cpl.
3	2560927	Keyboard foil
4	2560916	Synchronous motor cpl.
5	2533163	Tothed belt pulley for motor
6	1103725	Toothed belt
7	1115515	Display LCD
8	2560896	Control PCB
9	1103722	Transformer cpl.
10	1103719	Humidity sensor cpl.
11	1103936	Support Mesh
12	1106228	Z85 Coarse dust filter (2 pcs)
	1109907	Z26 Quattro filter (2 pcs)
13	1103286	Filter frame
14	1110666	Microswitch door lock
15	1102217	Drive wheel cpl.
16	1100034	Mains lead CH
	1110153	Mains lead EU
	1116469	Mains lead Singapore
17	1103714	Microswitch filter wall
18	2560893	Roller (2 pcs)
19	1103737	Retainer spring cpl.
20	1114709	Air Intake grill (2 pcs)
	2561711	Air Intake grill special color (2 pcs) (RAL or NCS code according type plate)
21	2560889	Handle
22	1102394	Door locking set
23	2560883	Stop lever cpl. (left)
24	2560884	Stop lever cpl. (right)
25	1103732	Door arresting set
26	2560917	Hinged plate cpl.
27	2524412	Insulation cap + socket (2 pcs)
28	2525859	Support ionisation electrode cpl. (2 pcs)
29	1115356	Ionisation electrode (2 pcs)
30	2560898	Level switch
31	1110529	Humidification drum
32	1100465	Z87 Evaporator mat neutral
	1110398	Z57 AC-evaporator mat
33	2560894	Retaining net
34	1109953	Base tub cpl.
35	1101326	Bearings and rollers (4 pcs)
36	2524759	Radio humidity sensor
37	2525353	Receiver module
38	1102957	Fuse 5x20 1.25A T (3 pcs)
	2560932	Fuse 5x20 2.5A T (3 pcs)
---	1119520	Ionisation cable
60	2525260	Valve unit cpl.
61	2560895	Water supply armored
62	2542955	Flat gasket $\varnothing 24/17 \times 2$ (5 pcs)
63	2543402	Gasket 3/4" / $\varnothing 24 \times \varnothing 15 \times 2$ mm (5 pcs)
64	2560924	Level safety switch A-type
65	2560933	Side cover A-type
	2561713	Side cover A-type special color (RAL or NCS code according type plate)



CONSULTING, SALES AND SERVICE:

Solutions for Indoor Climate



Reg.No. 40002-2

avrora-arm.ru
+7 (495) 956-62-18

**walter
meier**