

CENTRE FLANGED BUTTERFLY VALVE TYPE M 015-A



The butterfly valve with centre flange enables the one-sided lugging of pipes.

TECHNICAL DATA

Nominal diameter:	DN 80 - DN 400
Face-to-face:	EN 558 Series 20 ISO 5752 Series 20 API 609 Table 1
Flange accommodation:	EN 1092 PN 10/16 ASME Class 150 AS 4087 PN 16
Flange Surface Design:	EN 1092 Form A/B ASME RF
Top flange:	EN ISO 5211
Marking:	EN 19
Tightness check:	EN 12266 (Leakage rate A) ISO 5208, Category 3
Temperature range:	-20°C to +200°C (depending on pressure, medium and material)
Operating pressure:	max. 16 bar
Vacuum:	0,2 bar absolute (depending on medium and temperature)

FEATURES

- Can be used as control valve or shut-off valve.
- Insulation height as per plant regulations
- Triple shaft bearings prevent shaft deflection and guarantee optimum guidance even after many years of operational service.
- Maintenance-free
- Can be disassembled, material-specific recycling possible.
- At the maximum pressure from DN 200 a through-going shaft (TS-version) is delivered.
- For paint and lacquers, a silicon-free version is available

GENERAL APPLICATIONS:

- Chemical and petrochemical industries
- Water and waste water technology
- Pneumatic materials handling technology
- Shipbuilding
- Surface technology
- Food industry
- Civil engineering
- For paint and lacquers, a silicon-free Version is available.



CENTRE FLANGED BUTTERFLY VALVE TYPE M 015-A

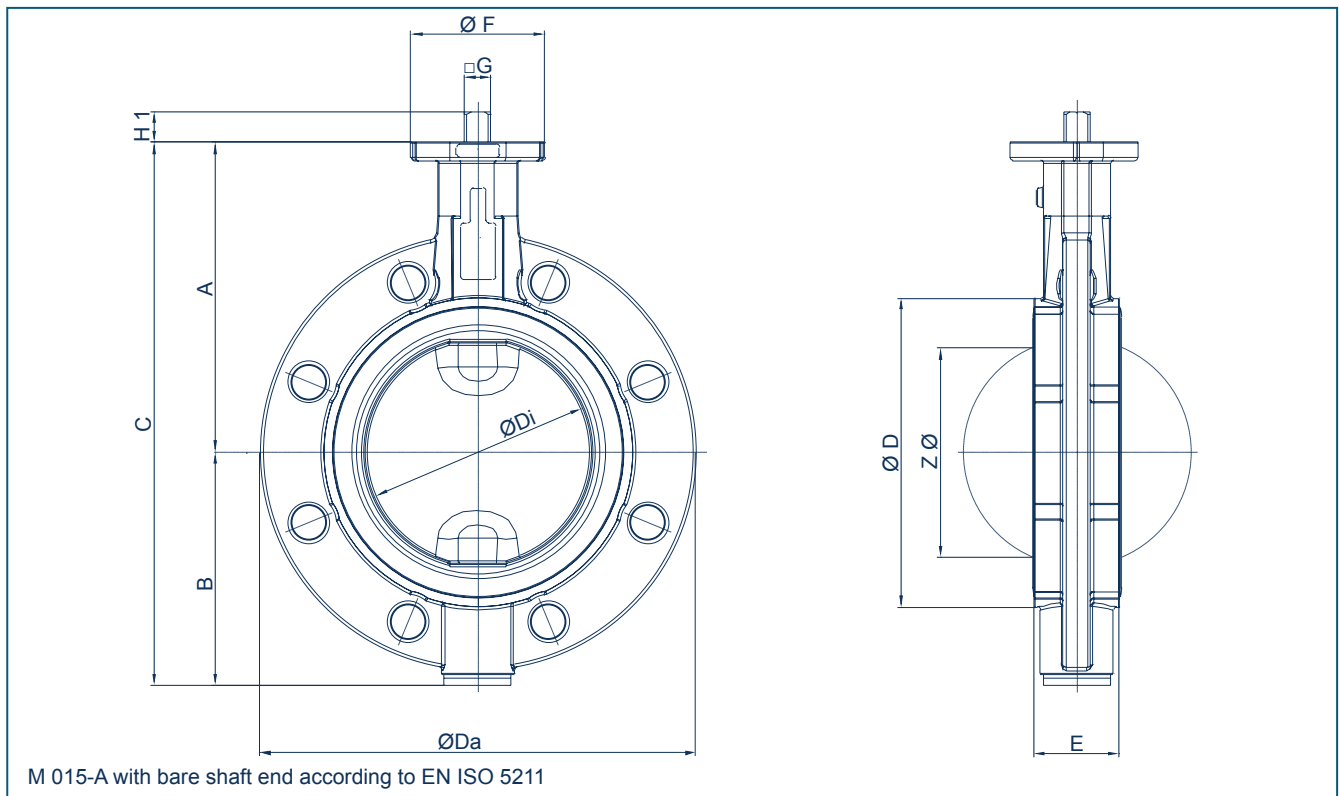

DN [mm]	Size [in]	Dimensions [mm]													2 Piece shaft	TS- shaft
		A	B	C	D	Di	Da		E	F	Flange	G	H1	Z		
80	3	157	105	262	128	79	200	200	46	65	F05	14	17	64	4,7	-
100	4	168	115	282	145	99	220	220	52	65	F05	14	17	84	5,8	-
125	5	180	127	307	180	124	250	250	56	65	F05	14	17	110	7,8	-
150	6	203	152	355	202	148	285	285	56	88	F07	17	20	137	10,9	11,4
200	8	229	178	406	250	199	340	340	60	88	F07	17	20	189	14,8	15,9
250	10	266	213	479	314	248	395	405	68	125	F10	22	24	239	26,0	29,4
300	12	291	238	529	360	297	445	460	78	125	F10	22	24	287	34,2	37,3
350	14	332	270	602	415	338	505	520	78	150	F12	27	29	328	50,5	56,5
400	16	363	314	677	470	390	565	580	102	150	F12	27	29	376	68,0	75,3

Subject to change without notice

CENTRE FLANGED BUTTERFLY VALVE TYPE M 015-A

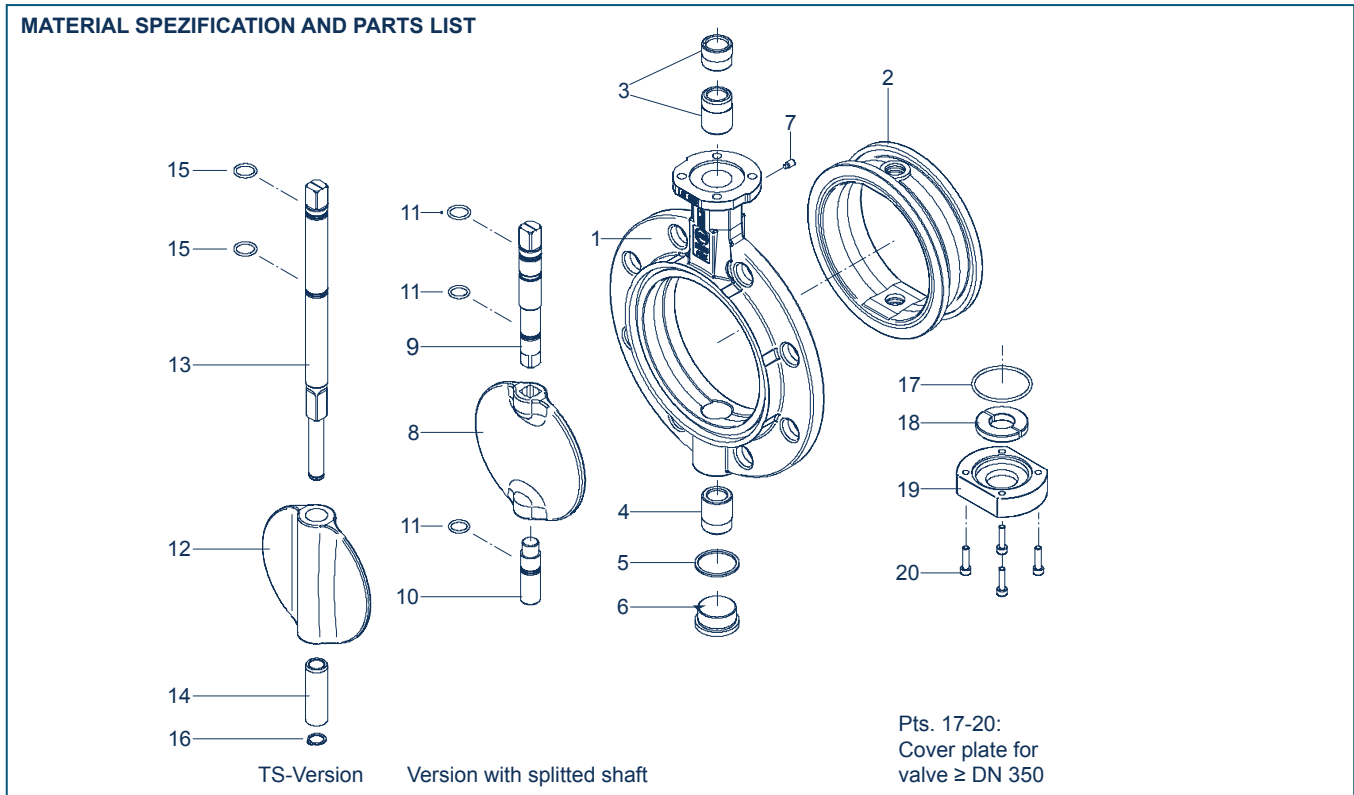

Pt.	Description	Material	Material-No.	ASTM	Pt.	Description	Material	Material-No.	ASTM
1	Body	Grey Cast Iron	GGG-40	0.7040	60-40-18	11	O-ring	NBR	Nitrile butadiene rubber
2	Seat	NBR	Nitrile butadiene rubber				FPM	Fluorocarbon rubber	
		EPDM	Ethylene propylene diene monomer rubber			12	TS-disc	Nodular Cast Iron	GGG-40
		CSM	Chlorosulfonated polyethylene rubber					Stainless Steel	G-X5CrNiMo19-11-2
		FPM	Fluorocarbon rubber					Aluminium Bronze	G-CuAl10Ni
		VSI	Silicon rubber					Coating	Halar, Rilsan
		SBR-green	Styrene butadiene rubber					Surface quality	electropolished, mirror finished
3/4	Bearing bush	Brass	MS 58	2.0401	B 45	13	TS-shaft	Stainless Steel	X14CrMoS17
		Polyamide	PA 66						X39CrMo17-1
		PTFE	Polytetrafluorethylene						X5CrNiMo17-12-2
5	Seal DIN 7603	Copper	Cu		Copper	14	Sleeve	Aluminum Bronze	CuAl10Ni
6	Plug screw DIN 908	Stainless Steel	G-X5CrNiMo19-11-2	1.4408	CF8M	15	O-ring	Stainless Steel	X5CrNi18-10
7	Set screw DIN 915	Steel	45 H galvanized					NBR	Nitrile butadiene rubber
		Stainless Steel	A4-70		B8M	16	Retaining ring	FPM	Fluorocarbon rubber
8	Disc	Steel	St 52.3	1.0570	572-50	17	O-ring	Stainless Steel	X39CrMo17-1
		Stainless Steel	G-X5CrNiMo19-11-2	1.4301	304			NBR	Nitrile butadiene rubber
			G-X6CrNiMo18-10	1.4408	CF8M	18	Shaft retainer	Brass	MS 58
			X2CrNiMo17-12-2	1.4404	316 L			Aluminium Bronze	G-CuAl10Ni
			X6CrNiMoTi17-12-2	1.4571	316 Ti	19	Cover plate	Grey Cast Iron	GG-25
			X2CrNiMoN22-5-3	1.4469	F 51			Aluminum Bronze	CuAl10Ni
			Hastelloy	2.4883	Hastelloy	20	Screw	Steel	45 H galvanized
		Aluminium Bronze	G-CuAl10Ni	2.0975	C 95800			Stainless Steel	A2-70
		Coating	Halar, Rilsan, NBR, EPDM						A4-70
		Surface quality	electropolished, mirror finished						
9/10	Shafts	Stainless Steel	X39CrMo17-1	1.4122					
			X14CrMoS17	1.4104	430 F				
			X5/(X2)CrNiMo17-12-2	1.4401/1.4404	316				
			Hastelloy	2.4883	Hastelloy				
		Aluminum Bronze	CuAl10Ni	2.0975					
									Other materials upon request

Subject to change without notice

CENTRE FLANGED BUTTERFLY VALVE TYPE M 015-A

TORQUE

- The values listed in the table are initial breakaway torques, taken with liquids and lubricant media.

- Please regard these as approximate values, as the objective value depends on different factors like pressure, medium, rubber, quality, temperature ... etc.

- Our engineers look forward to help you with exact values for your application.

- Powdery (non-lubricant) media
Md x 1,3

- Dry gases/high viscous media
Md x 1,2

DN [mm]	Size [in]	Adapted Disc Size Pressure Rating			
		3 bar disc	6 bar disc	10 bar disc	16 bar disc
80	3	8	10	18	24
100	4	9	18	28	37
125	5	15	22	45	59
150	6	36	45	78	125
200	8	59	76	140	200
250	10	150	180	200	240
300	12	200	240	280	360
350	14	350	540	610	700
400	16	420	620	750	850

All values in Nm

K_v-VALUES

- The K_v-values [m³ per hour] is the flow of water at a temperature of 5°C to 30°C (41°F to 86°F) at Δp of 1 bar

- The K_v-values specified are based on tests carried out by the Delfter Hydraulics Laboratories, the Netherlands

- Permissible velocity of flow
V_{max} 4,5 m/s for liquids,
V_{max} 70 m/s for gases

- The throttle function is linear at an angle 30° to 70°

- Avoid cavitation

For further values, please contact our engineers.

DN [mm]	Size [in]	Opening angle α°							
		20°	30°	40°	50°	60°	70°	80°	90°
80	3	15,6	20,6	51,4	102	165	234	304	368
100	4	24,9	39,8	96,5	183	288	398	503	589
125	5	51,8	67,2	135	256	428	652	926	1250
150	6	76,5	97,3	197	375	629	957	1360	1830
200	8	137	187	373	697	1160	1760	2510	3400
250	10	227	271	563	1090	1850	2830	4010	5390
300	12	287	409	820	1550	2610	4050	5880	8120
350	14	399	488	1070	2110	3590	5480	7760	10400
400	16	557	703	1360	2600	4470	7060	10400	14600

Subject to change without notice