

## EP100 Analog Positioner

The analog Positioner EP100 with analog input 4 to 20 mA is designed to operate pneumatic valve actuators. It offers an easy adjustment by means of switches and potentiometers. The modular structure of the EP positioner series enables the feasibility to re-fitt optional equipment (limit switch).

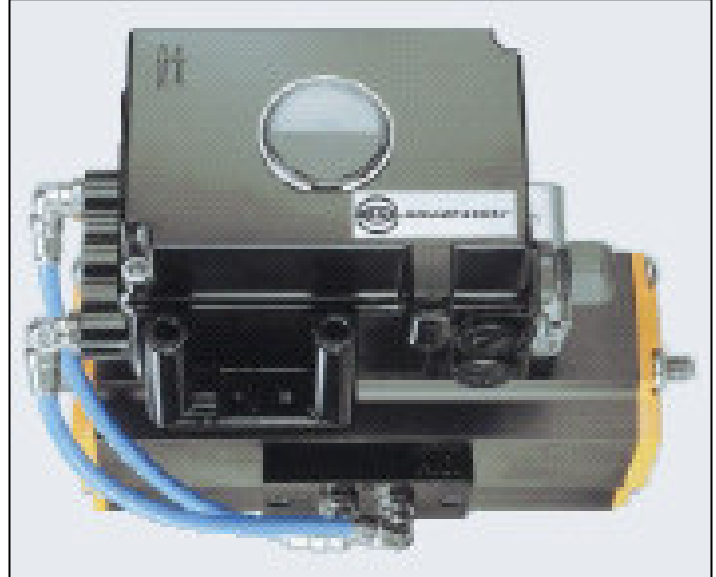

### FEATURES

- Configuration by means of switches and potentiometers
- Load 300 Ω
- Low air consumption
- Angle range up to 95 degree
- Supply air pressure up to 6 bar (90 psig)
- Single acting or double acting
- Mechanical travel indicator
- Reverse polarity protection and interlock diode
- Attachment to rotary actuators according to VDI/VDE 3845
- Failsafe position in case of failure of electronics
- Protection class IP 65
- Additional equipments (compatible to EP200):  
Integrated inductive limit switches,  
independent of device electronics
- Accessories (compatible to EP200):  
Gauge attachment for supply air and outputs  
Booster relay

Repair and maintenance operations must be carried out by qualified personnel!

---

**TABLE OF CONTENTS**

CHAP: CONTENT	PAGE	CHAP: CONTENT	PAGE
<b>1 METHOD OF OPERATION.</b>	<b>3</b>	<b>8 DECOMMISSIONING</b>	<b>16</b>
1.1 General	3	<b>9 TROUBLE-SHOOTING GUIDE</b>	<b>17</b>
1.2 Block diagram	3	<b>10 MAINTENANCE</b>	<b>18</b>
1.3 Operation	3	10.1 General	18
1.4 Safety Requirements	4	10.2 Supply filter replacement	18
<b>2 LABELS</b>	<b>5</b>	10.3 Removal of the electronics unit	18
<b>3 DESIGN</b>	<b>6</b>	10.3.1 Conversion of positioner	18
3.1 Pneumatic accessories	7	10.4 Replacement of mechanical and pneumatic units	19
<b>4 MOUNTING TO ROTARY ACTUATORS</b>	<b>8</b>	10.4.1 Amplifier replacement	19
4.1 Type of mount	8	10.4.2 Pre-amplifier replacement	19
4.2 Preparation of the positioner	8	10.4.3 IP-module replacement	19
4.3 Preparation of the actuator	9	10.4.4 Feedback unit replacement	19
4.4 Mounting of the positioner	9	<b>11 OPTIONS</b>	<b>20</b>
<b>5 PNEUMATIC CONNECTIONS</b>	<b>10</b>	11.1 Limit switch	20
<b>6 ELECTRICAL CONNECTION</b>	<b>11</b>	11.1.1 2-wire indicator	21
<b>7 START-UP</b>	<b>12</b>	11.1.2 3-wire indicator	21
7.1 General	12	11.2 Position feedback 4 – 20 mA	21
7.2 Setting of:		<b>12 APPENDIX</b>	
- Direction of rotation of feedback shaft	13	<b>SYSTEM CONFIGURATION</b>	<b>22</b>
7.3 - Setting of Input Signal Range		<b>DIMENSIONS</b>	<b>23</b>
- Split Range	14		
7.4 - Gain (G)	15		
7.5 - Zero (ZERO) and Span (S)	15		
7.6 - Damping (D)	15		
7.7 - Travel indicator	15		
7.8 Air reducing throttles	16		
7.9 Basic adjustment of electronics	16		
7.10 Pneumatic test	16		

## 1 METHOD OF OPERATION

### 1.1 General

The intelligent positioner EP100 1 and the pneumatic actuator 2 form a control loop with the setpoint value  $w$  (from master controller or control system), the output pressure  $y$  and the position  $x$  of the actuator on valve 3. The positioner can be attached to both linear actuators and rotary actuators. Actuators with spring force are controlled by a single acting positioner.

Actuators without spring force are controlled by a double acting positioner. The positioner can be operated by means of switches and potentiometers.

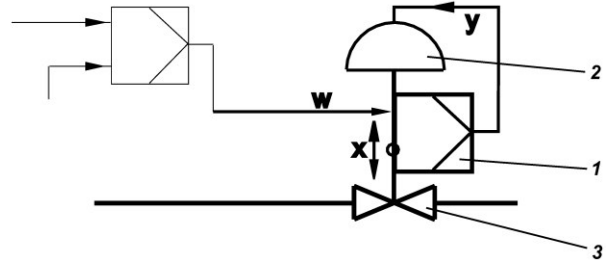

For the supply air, we recommend a filter regulator...

### 1.2 Block diagram

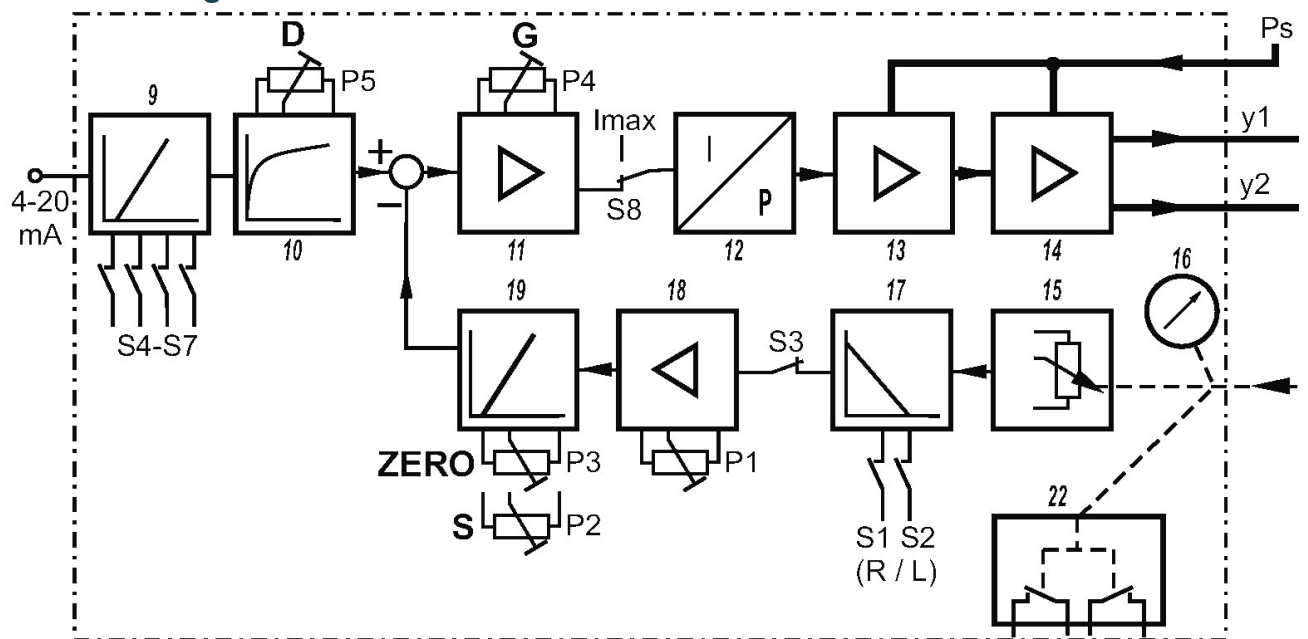

### 1.3 Operation

The supply of the electronics unit is diverted from the current signal 4 to 20 mA at the input.

The current value is measured and is suited in input circuit 9 to the desired input range (control action or split range) via switches S4 - S7. In circuit 10 the signal is provided with an adjustable time constant settable via potentiometer P5.

The resulting internal signal is guided to the analog control circuit 11, the gain of which is adjustable via potentiometer P4. The output of the control circuit drives the electromechanic converter (IP module) 12, which controls the analog single acting or double acting pneumatic amplifier 14 through the preamplifier 13. The output of the amplifier 14 is the output pressure  $y$  ( $y_1, y_2$ ) to the actuator. The pneumatic amplifiers are supplied with supply air  $P_s$  1.4 to 6 bar (20 to 90 psig).

The position  $x$  of the actuator is measured by the position sensor (conductive plastic potentiometer) 15. The desired direction of rotation is set in 17 via switches S1 and S2. The SPAN is suited to the stroke / rotation angle range via potentiometer P2, while ZERO is set in 19 via potentiometer P3. With switch S3 potentiometer P1 provides an internal zero adjustment in 18 carried out by the manufacturer (service function). The resulting feedback signal is guided to control circuit 11.

The IP module receives its maximum drive current via switch S8 enabling checking of the funktion of the pneumatic unit.

The position  $x$  of the actuator is independently displayed at the mechanical travel indicator 16.

The mechanical limit switch 22 (optional) enables independent alarm signals.

## 1.4 Safety requirements

### Accident prevention

This device complies with regulations for the prevention of accidents **Power-Driven Work Aids** (VGB 5) of 1st October 1985.

In option "limit switch" do not touch control vane during operation - danger of injuries!

### Electrical safety

This instrument satisfies the conditions for safety class III, overvoltage category I according to EN 61010-1 or IEC1010-1.

Any work on electrical parts must be done by qualified personnel if any supply is connected to the instrument.

The instrument must be used for its designated purpose and connected in accordance with its connection diagram (see pages 17 and 27).

Locally applicable installation regulations for electrical equipment must be observed, e.g. in the Federal Republic of Germany DIN VDE 0100 resp. DIN VDE 0800. The instrument contains no built-in fuses.

The instrument must be operated with safety extra low voltage SELV or SELV-E.

Safety precautions taken in the instrument may be rendered ineffectual if the instrument is not operated in accordance with the Master Instructions.

Limitation of power supplies for fire protection must be observed due to EN 61010-1, appendix F or IEC 1010-1.

### Explosion protection

(Only if ordered)

Technical data for explosion protection see Product Specifications Sheet PSS EVE0107 A-(en).

For installations located in explosive atmospheres, all relevant national regulations and installation conditions must be observed, e.g. in the Federal Republic of Germany ExV and DIN VDE 0165.

### Attention:

When repairing explosion-protected equipment, observe the national regulations.

Repairs involving parts must be manufacturer's original parts.

The following applies to the Federal Republic of Germany:

Repairs involving parts required for explosion protection must either be carried out by the manufacturer or by authorized personnel and confirmed by certificate.

### EMC and CE

For notes regarding Electromagnetic compatibility EMC and CE labels see Product Specifications Sheet PSS EVE0107 A-(en).

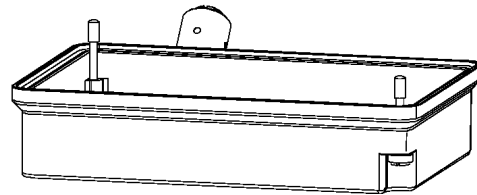
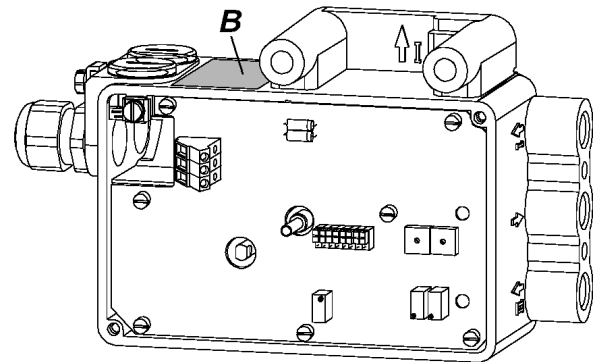
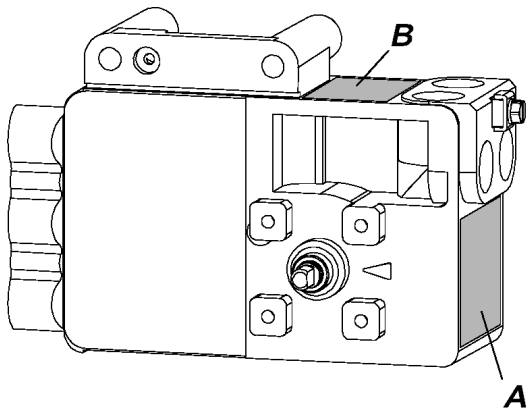

In order to ensure EMC protection, the electronic board has to be screwed to the housing.

## 2 LABELS



- A Nameplate
- B Additional label for option "Limit switches"

### Nameplate (Example)

	
<b>EP100-</b>	
SER.No [                      ]	ECEP [                      ]
ZULUFT / SUPPLY : max. 6 bar ( 90 psi )	
<input type="checkbox"/> EINFACH / SINGLE <input type="checkbox"/> DOPPELT / DOUBLE	
EINGANG / INPUT :    4 ... 20 mA	
	
REV. [                      ]	(0)

- EP100 [ Device specification, Model Code ]
- SER.No [ Serial number ]
- ECEP [  Number for special engineered version ]

## 3 DESIGN

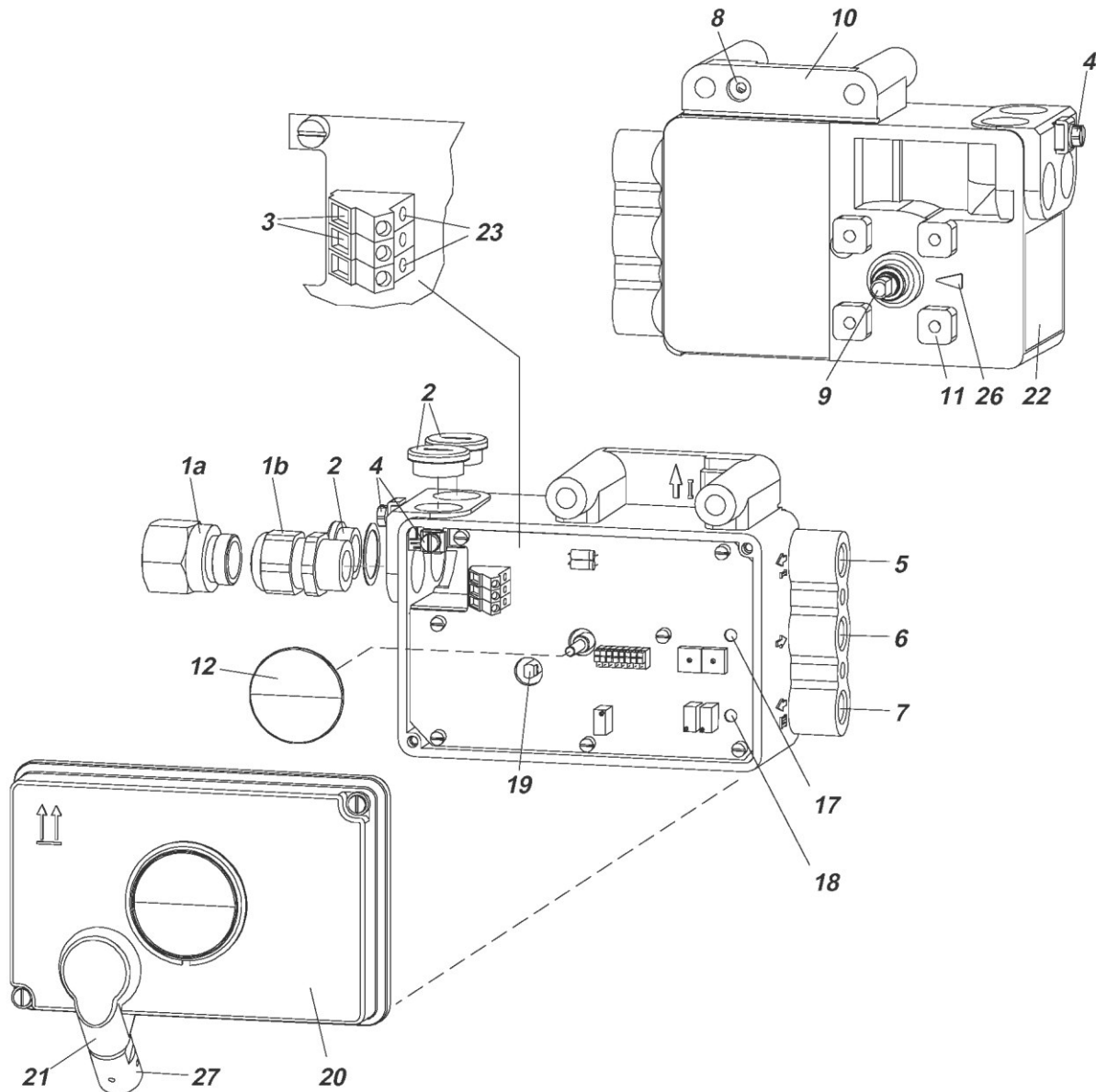

- |  |   |
|--|---|
| <b>1a</b> Adapter 1/2"-14NPT (see accessories)   | <b>11</b> Connection base for mounting to rotary actuators                                    |
| <b>1b</b> Cable gland PG 13.5  | <b>12</b> Travel indicator  |
| <b>2</b> Plug, interchangeable by Pos. 1   | <b>17</b> Air reducing throttle* for output I   |
| <b>3</b> Screw terminals 11+ 12- for input (w)<br>I- to measure input current (see also item 23) | <b>18</b> Air reducing throttle* for output II  |
| <b>4</b> Ground connection   | <b>19</b> Shaft for limit switch connection   |
| <b>5</b> Female thread 1/4-18 NPT for output I (y1)  | <b>20</b> Cover with window to 12   |
| <b>6</b> Female thread 1/4-18 NPT for air supply (s)   | <b>21</b> Air vent, dust and water protected  |
| <b>7</b> Female thread 1/4-18 NPT for output II (y2)   | <b>22</b> Nameplate   |
| <b>8</b> Direct connection hole for output I (y1)  | <b>23</b> Connections for current measurement, 2 mm dia.<br>(integrated in side of terminals) |
| <b>9</b> Feedback shaft  | <b>26</b> Arrow points to flat of feedback shaft at angle 0°                                  |
| <b>10</b> Connection manifold for mounting to linear actuators                                   | <b>27</b> Ball valve for protection class NEMA 4X   |

\* Service only

## 3.1 Pneumatic Accessories

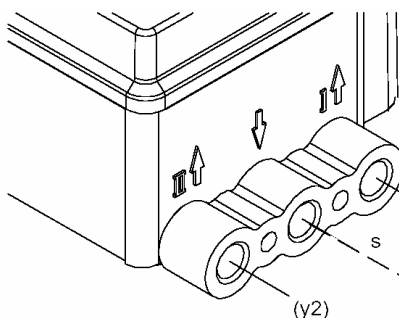

When mounting, check the proper seating of the O-rings and bolt on the accessories with the two M8 bolts. Unused outputs are closed by means of plastic plugs.

3x  
1/4-18 NPT

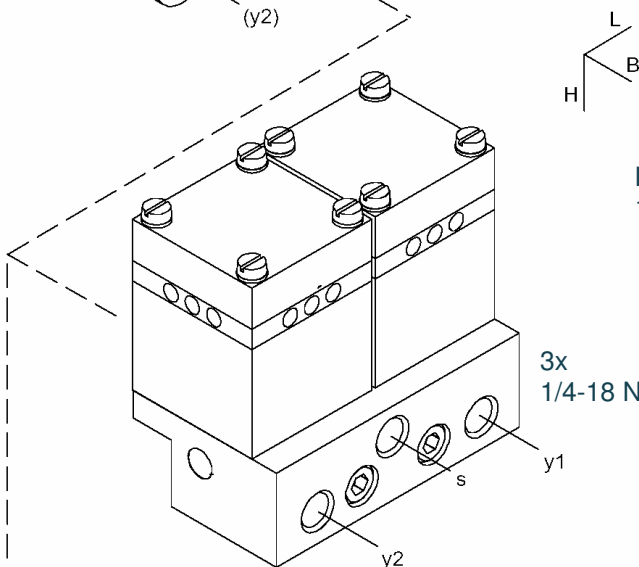

L x B x H =  
101,5 x 60 x 100,5 mm

3x  
1/4-18 NPT

**Code LEXG -G**  
Booster for double acting positioner

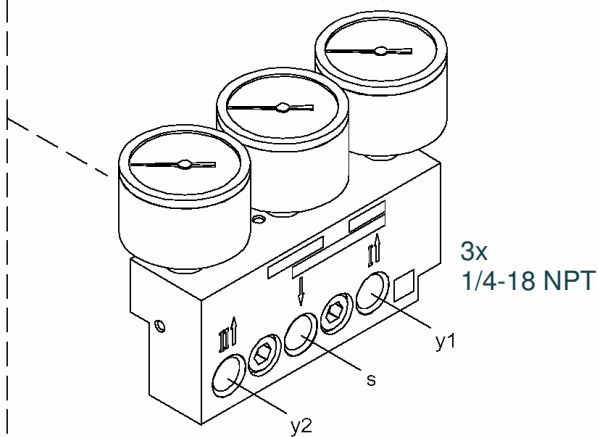

L x B x H =  
121 x 39 x 81 mm

3x  
1/4-18 NPT

**Code LEXG -M**  
Connection manifold for double acting positioner with pressure gauge for supply air s, outputs y1 and y2

3x G 1/8 für  
Manometer\*

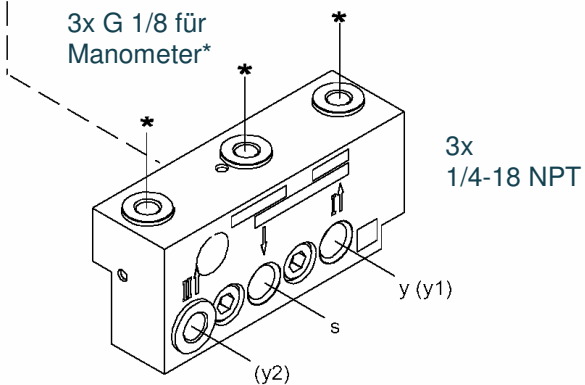

L x B x H =  
100 x 30 x 45 mm

3x  
1/4-18 NPT

**Code LEXG -N**  
Connection manifold for single or double acting positioner with threads G 1/8 for pressure gauge for supply air s, outputs y(y1) and (y2) (supplied without pressure gauge)





### 4.3 Preparation of the actuator

First the rotary adaptor is being prepared:

For attachment to a counter-clockwise or left turning actuator secure the stud screw **4** on the left side of the “**R**” in the threaded hole of the rotary adaptor (see the big “**L**” marked drawing below).

For attachment to a clockwise or right turning actuator secure the stud screw **4** on the right side of the “**L**” in the threaded hole of the rotary adaptor (see the big “**R**” marked drawing below).

Then the feed back shaft **9** should be turned with the bevelled side (flat part) according to the stud screw **4** (on the 0% position of the rotation indicator). Now screw and tighten the bolt in the coupling against the flat part of the feedback shaft (do not screw against the thread!). Finally turn the feedback shaft in such a way that the “**R**” or the “**L**” of the coupling points to the arrow **10** of the EP100 housing. Now place the rotary adaptor **3** with two washers **5** on the feedback shaft **9** of the positioner against the stop.

**Note :** When the product temperature rises, than the drive shaft **1** becomes longer. Therefore, the rotary adaptor **3** must be mounted so that approx. 1 mm (0.04 inch) of clearance results between the drive

shaft **1** and the rotary adaptor **3**. This is achieved by placing an appropriate number of washers **5** on the feedback shaft stub **9** before attaching the rotary adaptor. Two washers should result in a clearance of 1 mm.

Beginning and end positions of the actuator drive shaft **1** and feedback shaft **9** are marked in the figures below ( the big “**L**” for the left-rotating actuator and the big “**R**” for the right-rotating actuator) by light-grey arrows for the respective direction of rotation. The feedback shaft is now in the normal position corresponding to the failsafe position of the actuator. No shifting of feedback shaft anymore!

### 4.4 Mounting of positioner

EP100 positioner and actuator are in failsafe position. Attach the EP100 on the console in such a way that the catch of coupling **3** is guided into the groove of shaft **1**. Use bolt **2** to center and align the positioner to the actuator. Be careful not to shift shafts **1** and **9** and that both shafts are exactly flush. Fasten the EP100 positioner to the bracket by means of 4 lock washers and 4 screws M6 x 12.

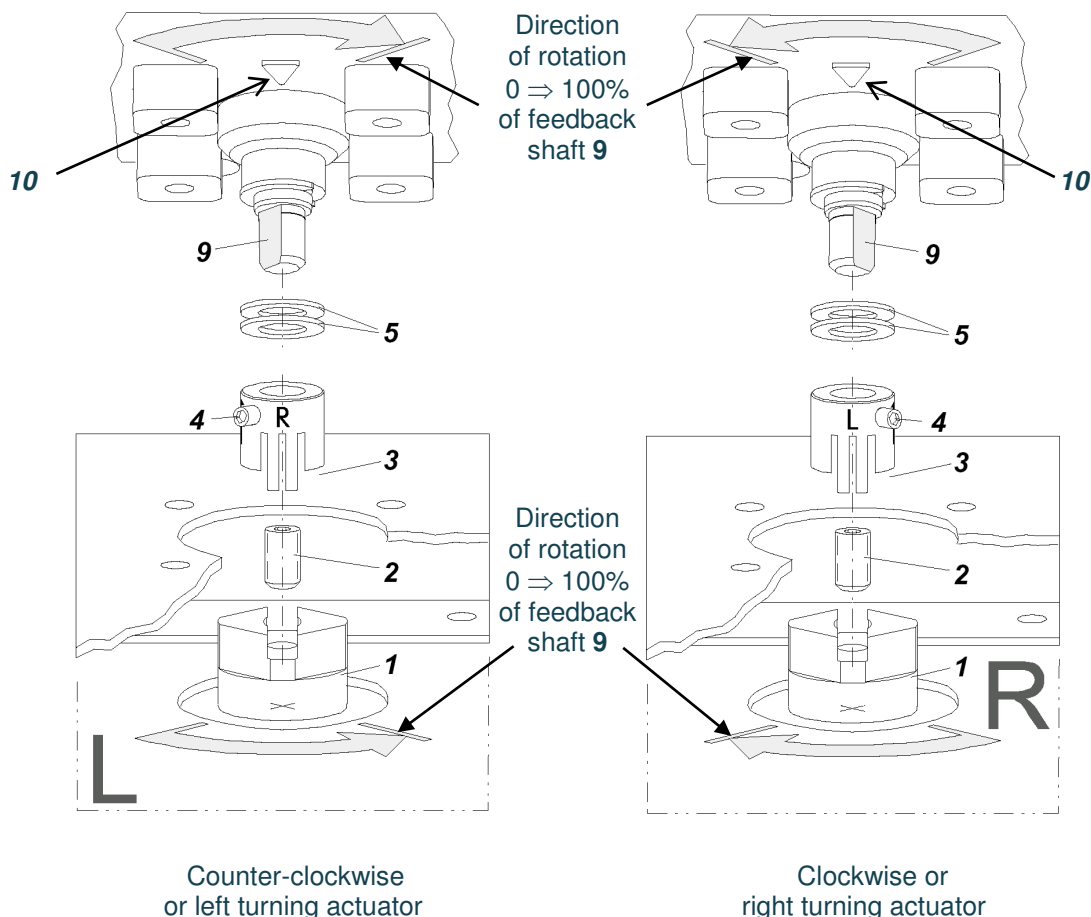

## 5 PNEUMATIC CONNECTIONS

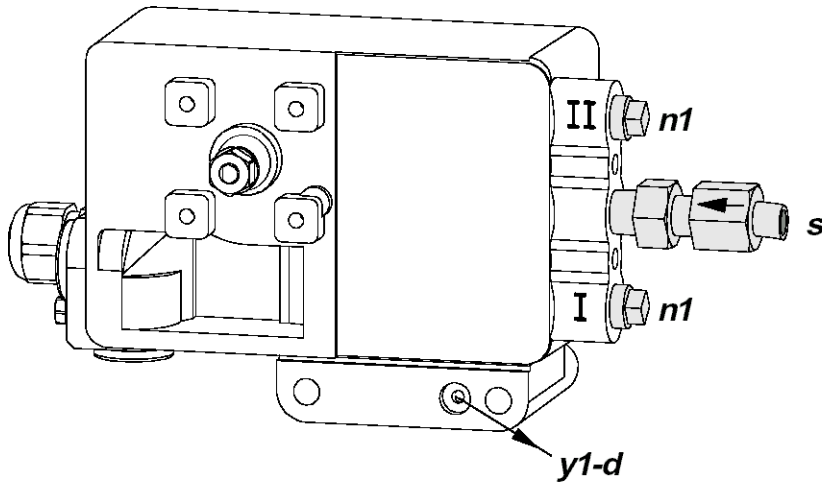

Following alignment and mounting of the positioner to the valve, pneumatic tubing has to be provided. The connection illustrations depend on the respective version.

### Explanation of abbreviations:

- s** Supply air
- y1-d** Output 1 for direct mounting, depressurized at currentless electronics. When using this output y1 as to be closed by means of hex. screw.
- y1** Output 1, depressurized at currentless electronics. When using this output, y1-d has to be closed by means of sealing screw and O-ring.
- y2** Output 2 for double-acting actuator. Full pressure at currentless electronics. Closed at single-acting actuator.
- n1** Hex. screw with NPT thread
- n2** Sealing screw with O-ring

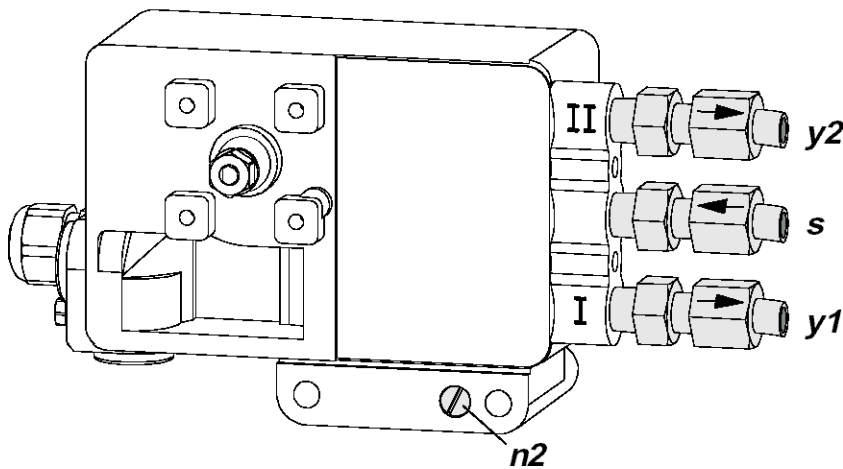
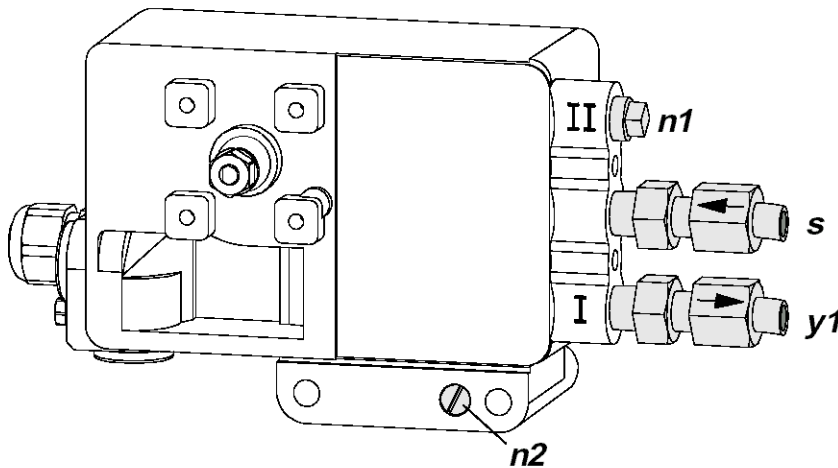

## 6 ELECTRICAL CONNECTION

The safety requirements on page 4 must be observed!  
 Unused cable glands should be closed off.  
 Guide cable through gland **1**. The gland is suitable for cable diameters of 6 to 12 mm (0.24 to 0.47 in).  
 Observe the tightness of the cable entry.  
 Provide electrical connection of input line at screw terminals **3** marked 11+ and 12 - . The terminals are suitable for wire cross-sections of 0.3 to 2.5 mm<sup>2</sup> (22 -14 AWG).

**Note:** When connecting shielded cable connect the cable shield only to the system! Do not connect the cable shield to the EP100!

Connection to terminals (pos. **3+**, **3-**):

11+ Input w+  
 12- Input w-

The input current can be measured at tip jacks 23+ and 23- (integrated in terminals, underneath the screws). The tip jacks fit plugs with a diameter of 2 mm (0.08 in).

In order to improve EMV protection by integration into local grounding the internal and external grounding conduct connection **4** is available.

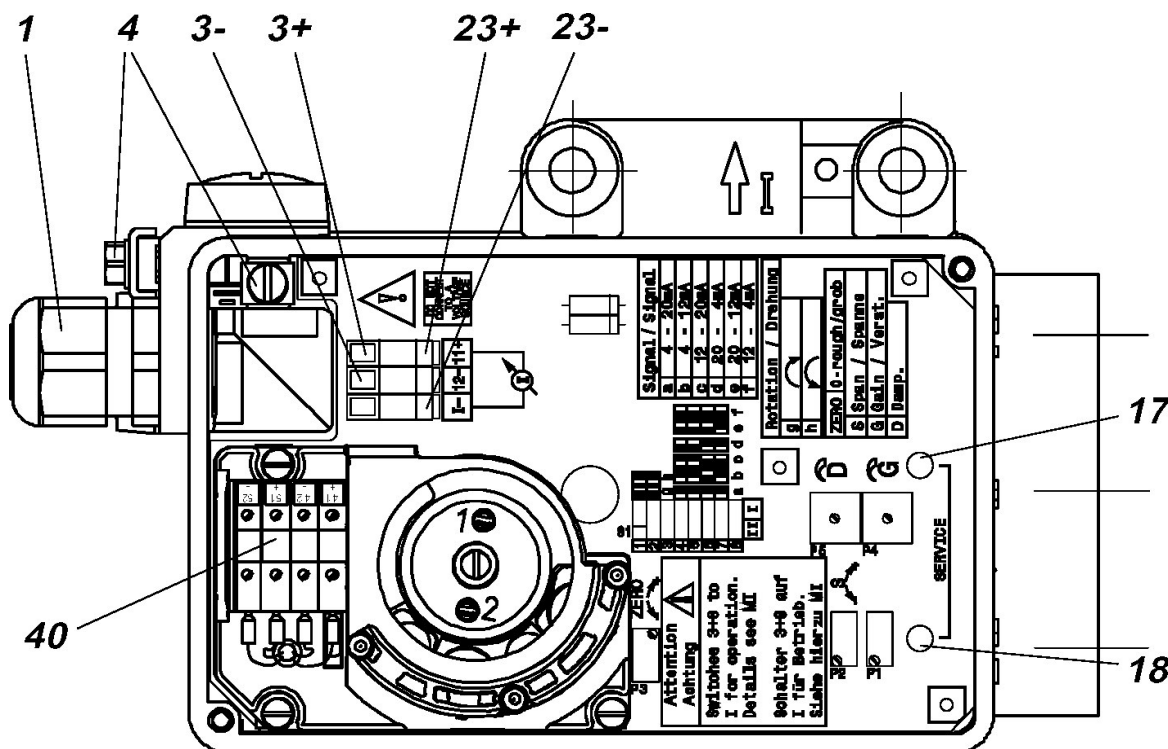

Optional equipment 'limit switch' (see terminals 40)

EP100-x-T, U via inductive sensor	
Mark	Signal
41 +	GW1
42 -	GW1
51 +	GW2
52 -	GW2

GW Binary output ext. supplied

## 7 START-UP

### 7.1 General

First of all, the nameplate should be checked, especially with respect to references to Ex / non- Ex, input signal, single / double acting. Before starting the positioner the EP100 has to be mounted to the actuator; an input signal 4 to 20 mA or split range have to be available. The supply air connection must have sufficient capacity and pressure of 1.4 to 6 bar (20 to 90 psig) and should not exceed the maximum operating pressure of the actuator. The EP100 can be adjusted by means of switches and potentiometers when the housing cover is opened.

**Attention:** Configuration using switches and potentiometers may interfere with operation of the actual process! During configuration it is recommended that there is no flow through the valve.

At initial start-up various adjustments have to be set. The following procedure is recommended:

- Setting of **direction of rotation** of feedback lever (chapter 7.2)
- Setting of **input signal range** e.g. 4 to 20 mA or split range (chapter 7.3)
- Setting of **gain** (chapter 7.4)
- Setting of **zero and span** (chapter 7.5)
- Setting of **damping** (time constant, chapter 7.6)
- The **position indicator** 12 is attached to the desired position after selection of the transmission at indicator shaft (chapter 7.7)
- The **air capacity throttles** at the pneumatic output (screws 17 and 18 underneath of the SERVICE openings) are factory-set to the operating value and are normally not reset (exception see chapter 7.8).
- When attaching the **housing cover** make sure that the venting opening points to the bottom

#### Settings via switches and potentiometers

For the setting of the EP100 and the adjustment of various parameters 8 dip switches and 5 potentiometers are available.

See electronics imprint as follows:

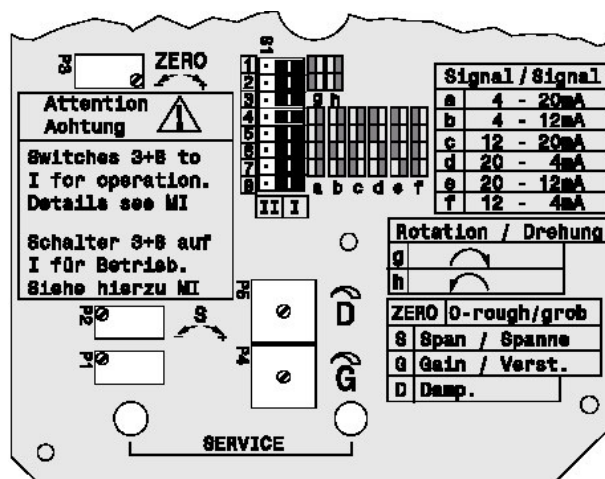

The potentiometers are for the setting of:

- Zero point (ZERO): P3
- Span (S): P2
- Gain (G): P4
- Damping (D): P5
- Electronics alignment: P1 <sup>1)</sup>

Single-threaded potentiometers with limited rotation angle to set gain (G) and damping (D) are available, where the actual position is indicated by an arrow. To set zero point (ZERO), span (S) and the electronics alignment<sup>1)</sup> multipletreaded potentiometers (approx. 30 rotations) without rotation limitation are used.

The **switches** are for the setting of:

- Direction of rotation of feedback lever (switches 1, 2)
- Electronics adjustment (switch 3) <sup>1)</sup>
- Signal range (switches 4, 5, 6 and 7)
- Pneumatic test (switch 8)

The switch numbers (1 through 8) are imprinted on the electronics. The possible switch position ("I" and "II") are imprinted below switch 8. The switch positions are defined as follows:

Switch Position "I":

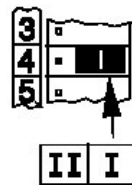

Switch Position II:



#### Caution!

Switches 3 and 8 must be during operation in position "I". Prior to resetting switches 1 to 8 it is recommended to shut-off the respective part of the installation since processes are activated influencing and disturbing the current process. Therefore, it is recommended that no medium flows through the valve during configuration..

<sup>1)</sup> Adjustment of electronic board (in workshop, see page 17)

### 7.2 Setting of direction of rotation of feedback shaft

If the actuator moves from starting to end position, the direction of rotation of the feedback shaft is to the right or left hand, depending on the mounting method of the positioner selected and on the configuration of the actuator (spring closes/ opens/ double-acting).

For proper functioning this direction of rotation must be set at positioner (via switches 1+2).

The direction of rotation is defined as direction of rotation of the feedback shaft from the starting to the end position looking at the positioner from the front. See following illustration (shown is: left hand mounting, spring closes, direction of rotation L).

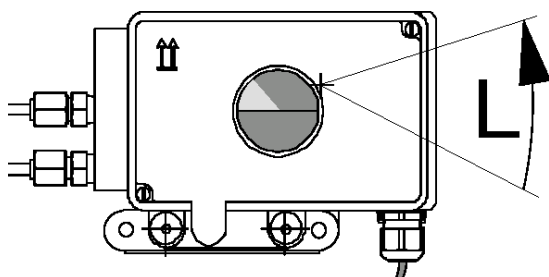

Direction of rotation of feedback shaft for a rotary actuator:

Actuator opens rotating to the left	Actuator opens rotating to the right
<b>L</b>	<b>R</b>

Direction of rotation of feedback shaft of the double-acting actuator is a. o. determined by the mounting side and the tubing of the pneumatic outputs to the actuator. It has to be considered that in a powerless EP100 the output y1 will become pressureless and y2 contains air supply pressure.

The direction of rotation of the feedback shaft is set via switches 1+2; see the following illustration.

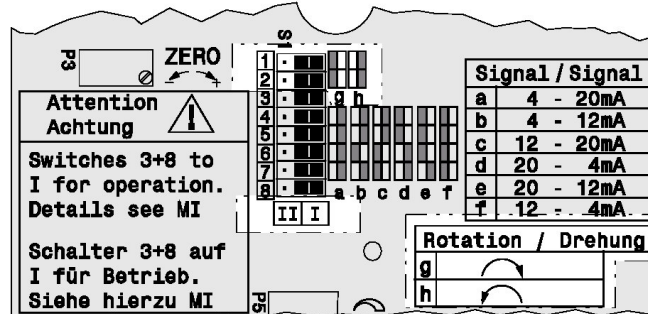

**L:** left-hand rotating feedback shaft      switch 1+2 on "I"  
**R:** right-hand rotating feedback shaft:      switch 1+2 on "II"

**Remarks:**

If the direction of rotation is not in the right manner, the actuator moves to the end position with full force, and the positioner cannot be controlled.

**Definitions**

- Stroke**      stroke range of the membrane actuator is defined for rotary actuator as angle, angle range.
- 0 % position**      is the mechanical impact at actually closed valve (caution if using handwheel and mechanically adjustable stroke limitation!)
- 100 % position**      is the mechanical impact at actually open valve.

### 7.3 Setting of Input Signal Range

The following input signal ranges can be set for the EP100 via switches 4 to 7:

0%	100%	item	S4	S5	S6	S7
4mA	20mA	A	I	I	I	I
4mA	12mA	B	I	I	II	I
12mA	20mA	C	I	I	II	II
20mA	4mA	D	II	II	I	I
20mA	12mA	E	II	II	II	I
12mA	4mA	F	II	II	II	II

The switch positions for the setting of various signal ranges are imprinted on the electronics. See illustration.

For 4 to 20mA the switches 4 to 7 are set to position "I" (as shown).

This concludes the setting of the input signal range!

#### Split Range

If several positioners are operated at one current loop in sequence with the standard signal 4 to 20 mA, individual valve positions may be allocated to each device, which also may overlap if necessary.

This function is useful if an additional control range is demanded which cannot be covered by one valve only. A valve of smaller nominal size can be applied overtaking the smallest quantities; a parallel mounted valve of bigger nominal size takes on the larger quantities.

**Example:** Setting the signal range to 12 to 20 mA  
It is recommended to shut off current of the positioner prior to resetting of the input signal range (turn-off input signal). The switches 4 and 5 are set to position "I" and switches 6 and 7 to position "II".

The individual switch positions are shown in the following illustration.

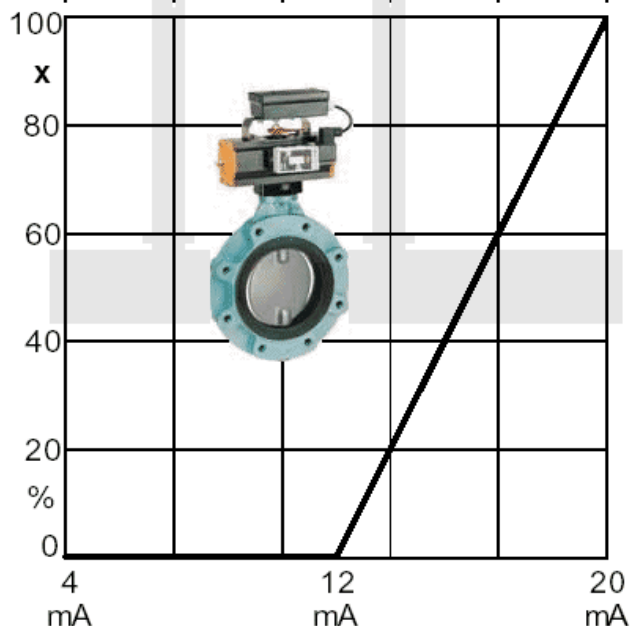
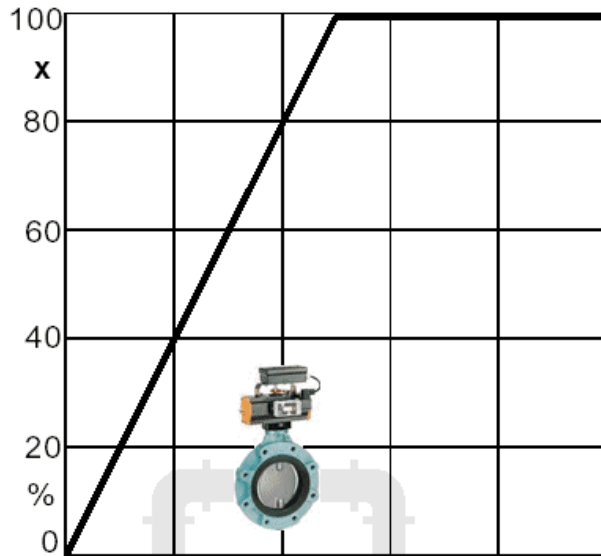
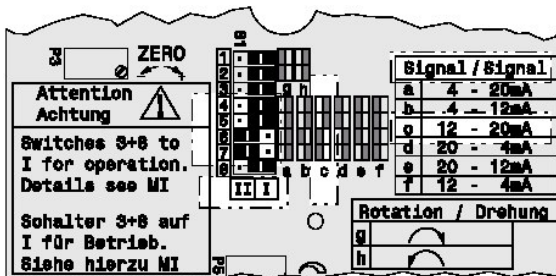

Split range, subdivision of input signal range Example: At low current, only the smaller valve positions; from approx. 50 % the large valve is added



### 7.4 Setting of gain (G)

The loop amplification of the positioner is set via potentiometer P4 for gain (G). The maximum possible gain is thereby determined by the stability behavior of the control loop. It is selected in such a way that the actuator no longer oscillates at constant given input value.

*Rotation to the right P4: amplification is increased*

*Rotation to the left P4: amplification is reduced*

If the positioner control loop oscillates, gain (G) must be reduced. It has to be considered that a change of gain changes the control deviation, therefore, requiring setting of the potentiometer for the position range (zero and span).

### 7.5 Setting of zero (ZERO) and span (S)

Following settings in chapters 7.2 through 7.4 at initial startup setting of zero point (ZERO) and span (S) are performed as follows:

- a) Enter starting value of command variable (beginning of stroke).
- b) Turn potentiometer P3 for zero point (ZERO) until actuator just begins to move from its end position.
  - Rotation to the right P3: zero point is increased*
  - Rotation to the left P3: zero point is reduced*
- c) Enter final value of variable (end of stroke)
- d) Turn potentiometer P2 for span (S) until actuator exactly reaches its end position.
  - Rotation to the right P2: span is increased*
  - Rotation to the left P2: span is reduced*

These settings influence amplification, therefore adjusting in chapter 7.4 may become necessary!

### 7.6 Setting of damping (D)

Potentiometer P5 for damping (D) influences the dynamic behavior of the actuator at a discontinuous change of the input signal. The input signal is provided with an additional time constant for this purpose. The time constant is only noticeable in the position control loop if the time constant set via potentiometer is larger than the position time of the actuator.

Rotation to the right P5: damping is increased  
Rotation to the left P5: damping is reduced

The effect of the positioning time may be checked by entering input signal jumps. The range limits and the gain are not influenced by a change.

### 7.7 Setting of the travel indicator

The mechanical travel indicator is coupled to the feedback shaft of the positioner by a gear. The gear has two selectable ratios 1 : 2 and 1 : 6.<sup>1)</sup>

#### Selection of gear ratio:

For rotation angles of the feedback shaft less than 30° select a ratio 1 : 6. This gear selection amplifies the feedback shaft rotation angle six times and for example, a 20° angle is shown as 120°.

For rotation angles greater than 30° select a ratio of 1 : 2. This gear selection amplifies the shaft rotation angle by a factor of two and for example, a 45° angle is shown as 90°.

For rotary actuators the rotation angle is equal to the rotation angle of the actuator. Consequently, a 90° rotation angle will result in a 180° display angle for the 1 : 2 gear ratio.

#### Setting gear ratio:

Remove travel indicator **12**. Pull out pin **12b** for a ratio 1 : 2 or push in the pin for a ratio 1 : 6. Use a smooth turning operation to free the gears and to set pin **12b** against the stop. See illustration.

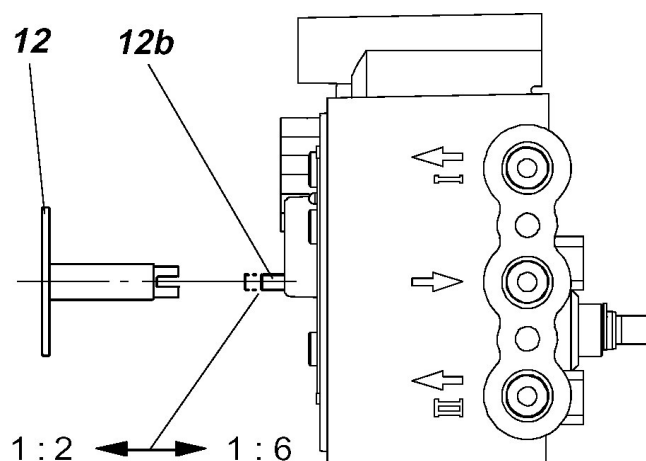

Turn the travel indicator **12** to the desired position, put it on the gear shaft against the stop and pinch the wire ring for secure coupling.

1) The values are rounded for making easier calculations. The exact ratios are 1 : 1.83 and 1 : 6.28:

## 7.8 Air reducing throttles

Attention: Service only

Air flow to the actuator may be reduced via air reducing throttles **17** and **18**.



Ex-factory the air capacity is non-throttled; generally, this is the most favorable setting. In the non-throttled condition the screw head is even with the amplifier surface. Since the flatness of the screw heads is not visible in the installed electronics, the basic setting can be restored as follows:

- turn off air supply
- carefully turn air reducing throttle screw clockwise until impact, thereafter 5 complete return rotations (counterclockwise)
- restart air supply

### Reducing of output air capacity

Attention: Service only

Output air capacity may be reduced in exceptional cases only in small volume actuators with a small spring range if after optimization of the control still oscillating tendency exists (amplification of control loop is too high). For this purpose turn air reducing throttle screws **17** and **18** to a maximum of 5 rotations clockwise.

**Caution:** Amplifier may be damaged if a loud noise can be heard from amplifier resulting from too strong reducing. Immediately turn back throttles significantly!

## 7.9 Basic adjustment of electronics

Attention: Service only

The electronics unit has been sufficiently factory-adjusted; an adjustment at delivery is not required. The potentiometer is secured by means of lacquer against unintentional operating.

In the event an adjustment of the electronics becomes necessary (e.g. following exchange of electronics) the procedure is as follows:

- a) Enter input current 4 mA.
- b) Switch S3 to "II": positioner control loop is opened.
- c) Turn potentiometer P1 until actuator just begins to move from its end position.
- d) Return S3 to "I".

## 7.10 Pneumatic test

Attention: Service only

To check the pneumatic parts of the positioner by directly applying current to the IP module (no control).

Procedure: Put switch 8 in position "II" (see illustration).



Attention!

Resetting of switch 8 initiates actions influencing and possibly disturbing the current process! Therefore, no medium should flow through the valve during these settings.

Setting switch 8 to position "II" actuates a pneumatic test checking the function of the positioners pneumatic system including its control. If switch 8 is set from position "I" (condition of operation) to position "II", the pressure in the actuator goes to nearly air supply pressure. The actuator moves to the direction associated with maximum pressure.

If no reaction is shown, check:

- does air supply exist?
- is plug connected to IP module?

If these items are okay, possibly the electronics or a pneumatic part are defect. Exchange see page 18.

During operation switch 8 must be in position "I" at all times!

## 8 DECOMMISSIONING

Before decommissioning the unit, disconnect supply air and the electrical input signal.



## 9 DIAGNOSIS

Fault	Possible cause	Beseitigung
Actuator does not react to existing input signal or to changes of input signal	Pneum. connections were interchanged	Check pneum. connections, see page 10
	Electric connections were interchanged	Check electric connections, see page 11
	Wrong setting of zero and span	Check, see page 15
	IP module or pneumatic part defective	Carry out Pneumatic Test, possibly change part, see page 19
	Direction of rotation interchanged	Change direction of rotation
Output pressure does not reach full capacity	Supply air capacity insufficient	Check air supply
	IP module defect	Carry out Pneumatic Test, possibly change module, see page 19
	Filter in air supply connection plugged	Exchange filter, see page 18
Actuator moves to end position	Positioner mounted on wrong side or switch 1+2 set faulty (R/L)	Check mounting side as per table page 13
	Pneumatik test still active (switch 8 = "II")	Return switch 8 to "I", see page 16
	Pneumatic connections were interchanged (double-acting version)	Check connections, see page 10
Unstable behaviour, position control circuit oscillates	Gain too high	Reduce gain, see page 15
	Friction on valve packing too great	Loosen packing gland slightly or replace
	Piston actuator: Friction at cylinder too great	Reduce gain, see page 15
Stroke range cannot be set	Positioner does not fully decompose pressure	Check air supply (max. 6 bar)
		Check gain, see page 15
		Carry out pneumatic test (switch 8 = "II"), see page 16
Pneumatic test is without effect	No air supply	Connect air supply
	No input signal	Connect input signal
	IP module is not connected, or IP module or a pneumatic part defective	Connect IP module, or exchange part (workshop)

## 10 MAINTENANCE

### 10.1 General

The positioner EP100 requires little maintenance. When replacing components during repair work, the safety requirements on page 4 must be observed!

### 10.2 Supply filter replacement

An obstructed supply filter can be replaced. Unscrew the air supply fitting, remove the filter and exchange the filter with a new one.

### 10.3 Removal of electronics unit

Pull off travel indicator **12**. To remove the electronics unit **40**, loosen the 7 screws at front, see illustration below.

Lift off electronics unit vertically to top. Disconnect plugs **41** and **42** (see page 25) from the board. Do not use tools to remove plugs because components could be damaged.

Tight-fitting plugs can be easily removed by tilting them diagonally inward before pulling them off.

Connect plugs **41** and **42** to the new electronics unit **40** and attach the new unit by using the 7 screws at front (attention with the cables).

### 10.3.1 Conversion of positioner

Positioner of the EP series consist of identical mechanical and pneumatic components and accessories.

A conversion to either a "digital" or "intelligent" positioner is possible by simply exchanging the electronics unit.

Procedure:

- exchange electronics unit, see chapter 10.3
- mark change on nameplate
- start-up - see associated master instructions:

#### Reference to explosion-proof devices:

Conversion of the electronics unit has to be considered as change to explosion-proof device, and therefore, only permitted in accordance with country specific regulations.

Valid in the Federal Republic of Germany: Conversion to be certified as change according to § 9 ElexV by an authorized expert.

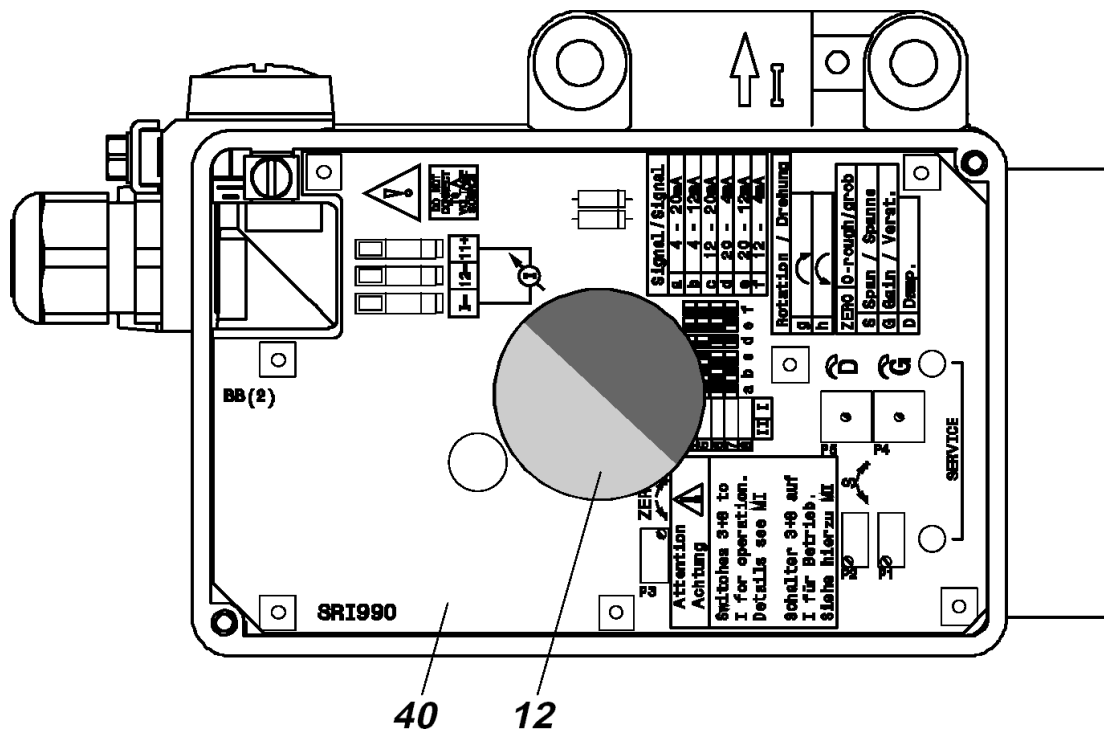

## 10.4 Replacement of mechanical and pneumatic units

First remove the electronics unit **40** (see preceding page).

### 10.4.1 Amplifier replacement

Release the pneumatic amplifier **43** from the base plate and replace O-rings between the amplifier and base plate<sup>1)</sup>.

Use 3 O-rings for a single-acting amplifier and 5 O-rings for a double-acting amplifier. If replacing a single-acting amplifier with a double acting, remove sealing screw **44** before installation.

The air capacity throttle screws have to be released until the screw head is even with the amplifier surface (= no throttling).

### 10.4.2 Preampifier replacement

Unscrew the preampifier **45** from the base plate by removing screws **46** and **47**.

Replace 4 O-rings between preampifier **45** and base plate<sup>1)</sup> and install new preampifier.

### 10.4.3 Replacement of IP module

Remove the IP module **48** from base plate and replace with new IP module. Replace the O-ring between IP module and base plate and install new IP module.

### 10.4.4 Replacement of Feedback unit

First remove feedback lever or rotary adapter from feedback shaft. Now remove retaining ring from feedback shaft **9** (see page 6). Remove screws and pull out complete unit **49** consisting of feedback shaft, gears and position sensor.

Insert new feedback unit **49** and secure with screws. Remember to replace the retaining ring at feedback shaft.

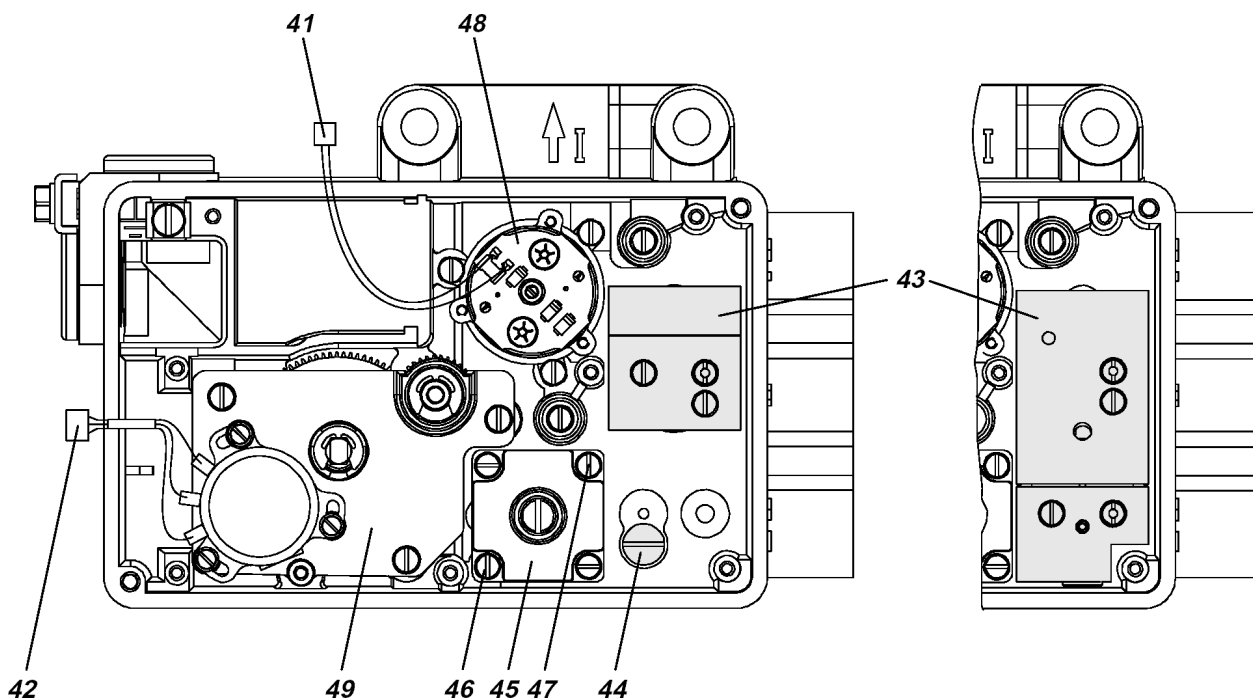

1) The base plate consists of a manifold and air ducts. O-rings are required to guarantee sealing of the mounted elements.

## 11 OPTION

### 11.1 Limit switch

Rebuild to this option resp. exchange

Remove three screws **1** including tooth lock washer from plastic cover.

Attach limit indicator **2** so that the flattened shaft end **19** contacts the groove of the limit indicator shaft in the positioner.

Attach limit indicator by means of three screws **3** and washers. The feedback shaft at back of positioner should easily be turnable, thereby also moving the vanes of the limit indicator. If this is not the case, loosen screws **3** and flush-align the shafts of positioner and limit switch (turn coupling shaft several times).

Replace short travel indicator **12** by long travel indicator.

Screw high cover **20** (or standard cover with insert frame) on housing.

#### Switch functions

Feedback lever, feedback shaft and the control vanes are all connected to each other, without an intermediate transmission. The control vanes are therefore moving simultaneously with the same angle rate as the feedback lever. The length of the control vane corresponds with the swing angle of 120°.

Both control vanes are located on different planes. Each control vane can be seen independently from the other, because each has its own sensor.

By adjusting the screws (after loosening the center screw **10**), the control vanes can be adjusted relatively to the angle rate, so that e.g. one vane dives into and another dives out of the sensor (see illustration).

#### Setting limit switch trigger points

Loosen center screw **10** (1-2 turns; do not remove!), otherwise the control vanes will be damaged during the following steps.

Set trigger point switch GW1:

Turn screw at number 1 until desired switch behavior is reached.

Set trigger point switch GW2:

Turn screw at number 2 until desired switch behavior is reached.

To fix switch points retighten center screw **10**.

Do not touch control vanes during operation, danger of injuries!

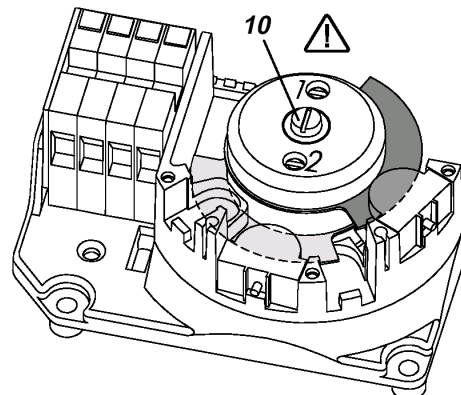
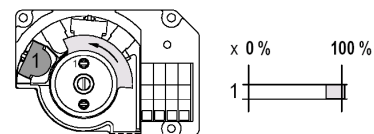
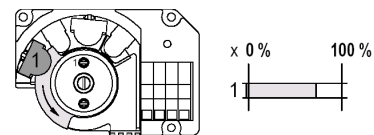
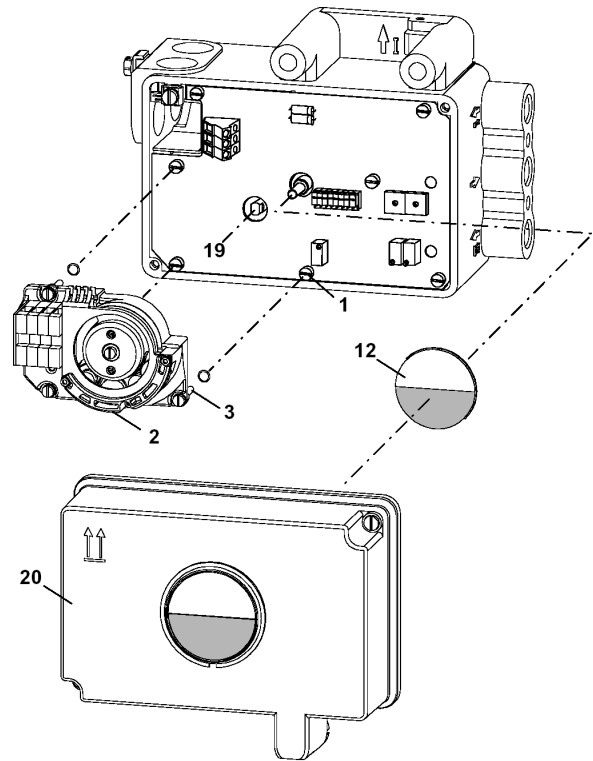

Levels of control vanes (illustration without cover)

### 11.1.1 2-wire limit switches

The limit switch module type "T/U" contains two 2-wire sensors (Type SJ2-N or SJ2-SN) according to the DIN 19234 or NAMUR (power supply 8 Volt DC).

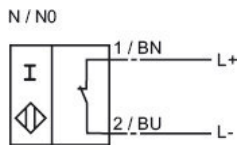

Connection to a switching amplifier with integrated control circuit.

41	(+) Sensor 1
42	(-) Sensor 1
51	(+) Sensor 2
52	(-) Sensor 2

### 11.1.2 3-wire limit switch

The limit switch module type "R" contains two 3-wire sensors (Type Si2-K08-AP7), 10..30 Volt DC, normally closed, PNP-Output.

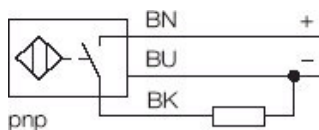

41	(-) Sensor 1 and Sensor 2
43	(+) Sensor 1 and Sensor 2
42	Switchable output Sensor 1
52	Switchable output Sensor 2

## 11.2 Position-feedback transmitter 4 - 20mA

The electrical position-feedback transmitter is an accessory either installed in the factory (no retrofit possible). It converts the rotary movement of an actuator into an electrical standard signal 4...20mA. The start-up procedure is described in step 7.1 – 7.7. The electronic connection of the position transmitter must be assured. Both LED's are then light up.

### Adjusting the start of the measuring range (4mA)

- Move the actuator to the starting position.
- Press push button S1 „Config Output 4mA“ longer than 2s. During this time LED 1 lights up. After 2s both LED's are light up again, the value for 4mA is stored.

### Adjusting the end of the measuring range (20mA)

- Move the actuator to the end position.
- Press push button S2 „Config Output 20mA“ longer than 2s. During this time LED 2 lights up. After 2s both LED's are light up again, the value for 20mA is stored.

### Random adjustment of the current values at the end points

- Move the actuator to the end position, where you want to adjust the current.
- Press both buttons simultaneously for about 2s. Then both LED's are alternating flashing in a slow frequency.
- With push button S1 „Config Output 4mA“ the output current value can be decreased and with push button S2 „Config Output 20mA“ the output current value can be increased. Pressing the buttons for a short moment results in a small change and pressing the button for a longer time results in a fast mode for a bigger change. The value of the current can be freely decreased between about 3,3 and increased up to 22,5 mA.
- Without any additional manipulations of the push buttons the new value is automatically saved. After a few seconds, the device returns into the normal operating mode, indicated by both LED's that are then light up again.

### Trouble shooting of the position transmitter

The components of the position transmitter are under constant surveillance by the installed micro controller. Errors are detected and indicated when both LED's are off or both LED's are parallel flashing at a fast frequency.

In the event of a fatal error, e.g. potentiometer not connected, an output current of more than 24mA will be shown in addition to the error indication given by the LED's (fast flashing).

In this case check the following:

- if the potentiometer is correctly connected to the electronic board.
- if the potentiometer is within its working span. When both LED's are off, the supply voltage should be checked (minimum tension, polarity).

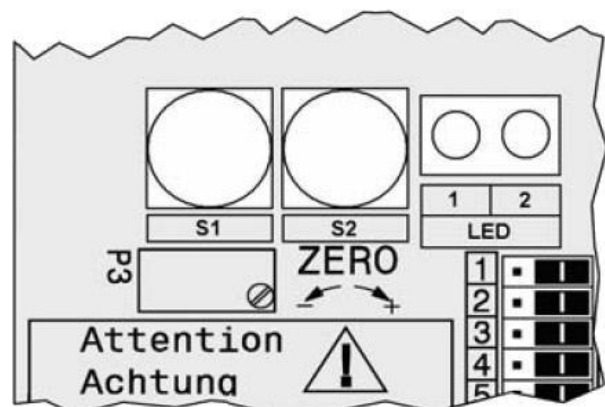

## 12 SYSTEM CONFIGURATION IN COMBINATION WITH CONTROL UNITS

 The safety requirements in page 4 must be observed!

### 12.1 Non-intrinsically safe operation

The EP100 can be connected directly to the 4 - 20 mA output of the process control system or controller. Load RL is approx. 300 Ohm.



### 12.2 Split range

If several actuators are to be controlled from an identical conduct variable and carry out full stroke only in a certain portion of this conduct variable, an individual EP100 is to be provided for each actuator. The zero and span of which can be set to the respectively desired partial range of the conduct variable. The positioners are electrically switched in series. It is important that the permissible load of the process control system or

controller is not exceeded (RL of an EP 100 is approx. 300 Ohm).

The output voltage (idle voltage) must be >8.5 V per connected positioner. The total line capacitance is not to exceed 1  $\mu$ F.

Example: 2-fold split range

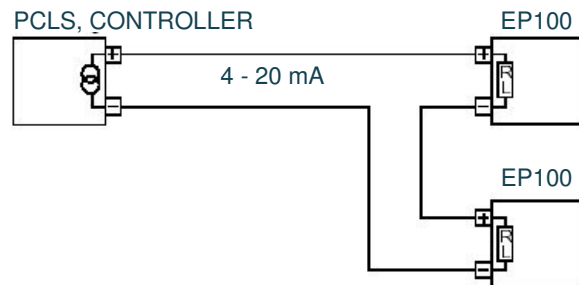

In the case of intrinsic safety, the same conditions as described in 12.1 apply. The settings of the position controllers are described on page 13.

**DIMENSIONS**

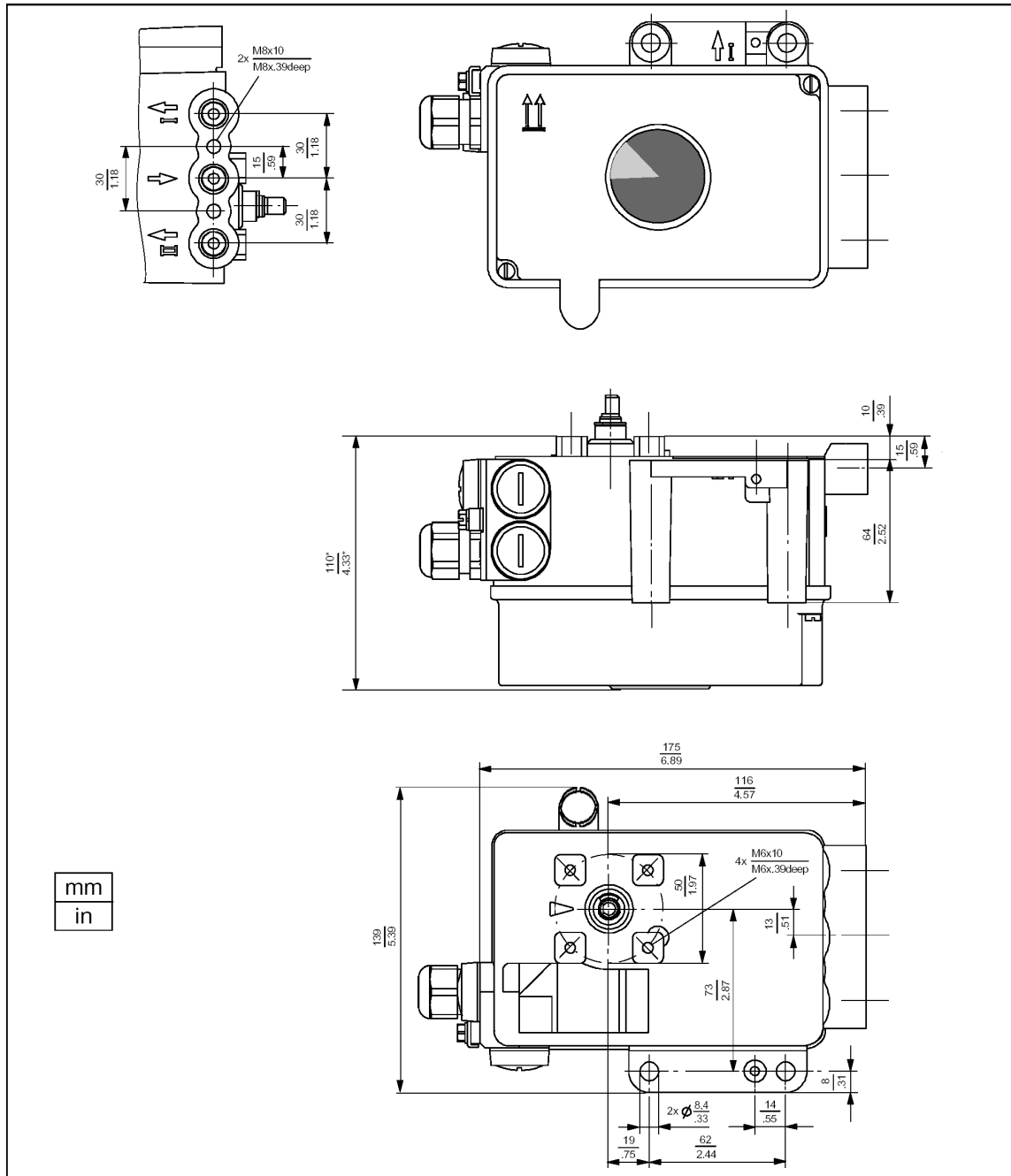

Subject to alterations - reprinting, copying and translation prohibited. Products and publications are normally quoted here without reference to existing patents, registered utility models or trademarks. The lack of any such reference does not justify the assumption that a product or symbol is free.