

# MODULAR SYSTEM FOR ELECTRIC ACTUATORS



Electric quarter turn actuators series E 65 - E 210 with modular system are designed to automate control valves.

## TECHNICAL DATA

Nominal torque:	100 Nm to 4000 Nm
Protection class:	IP67
Duty cycle:	up to Class C (max.1200 c/n) acc. to prEN 15714-2
Limit switches:	max. 250V AC, 3A
Torque control:	directional contact, max. 250V AC 5A
Switch box heater:	supply 230V AC permanently, 5W
Potentiometer:	1000 $\Omega$
Current feedback:	4-20mA, supply max. 30V DC
Thermal motor switch:	integrated
Insulation class:	F
Corrosion protection Class:	C4 acc. to prEN 15714-2, tested acc. to EN 60068-2-52
Cable entries:	4 x M20 x 1,5 $\varnothing$ -min = 6 mm $\varnothing$ -max = 13 mm
Operation temperature:	-20°C to +70°C
Hand wheel:	15 revolutions 90°
Hand wheel Torque:	4 Nm for E65 20 Nm for E110 35 Nm for E160 50 Nm for E210
Supply voltage:	from 110V AC/1~ to 480V AC/3~

## GENERAL APPLICATIONS

- Integrated torque control
- Digital control input
- Integrated 24V DC control voltage supply
- 5 digital feedback signals
- Switch box heater
- Prepared for further options
- Actuator mounting and optional modules as modular system
- Self-locking, separately capsuled worm gear ensures a safe positioning of the actuating element
- Top flange acc. to EN ISO 5211
- Replaceable shaft notch enables the adaption of different valves
- The optical position indicator shows the exact position of the actuating element



Complete equipment with additional board for positioner.

# DIMENSIONS MODULAR SYSTEM

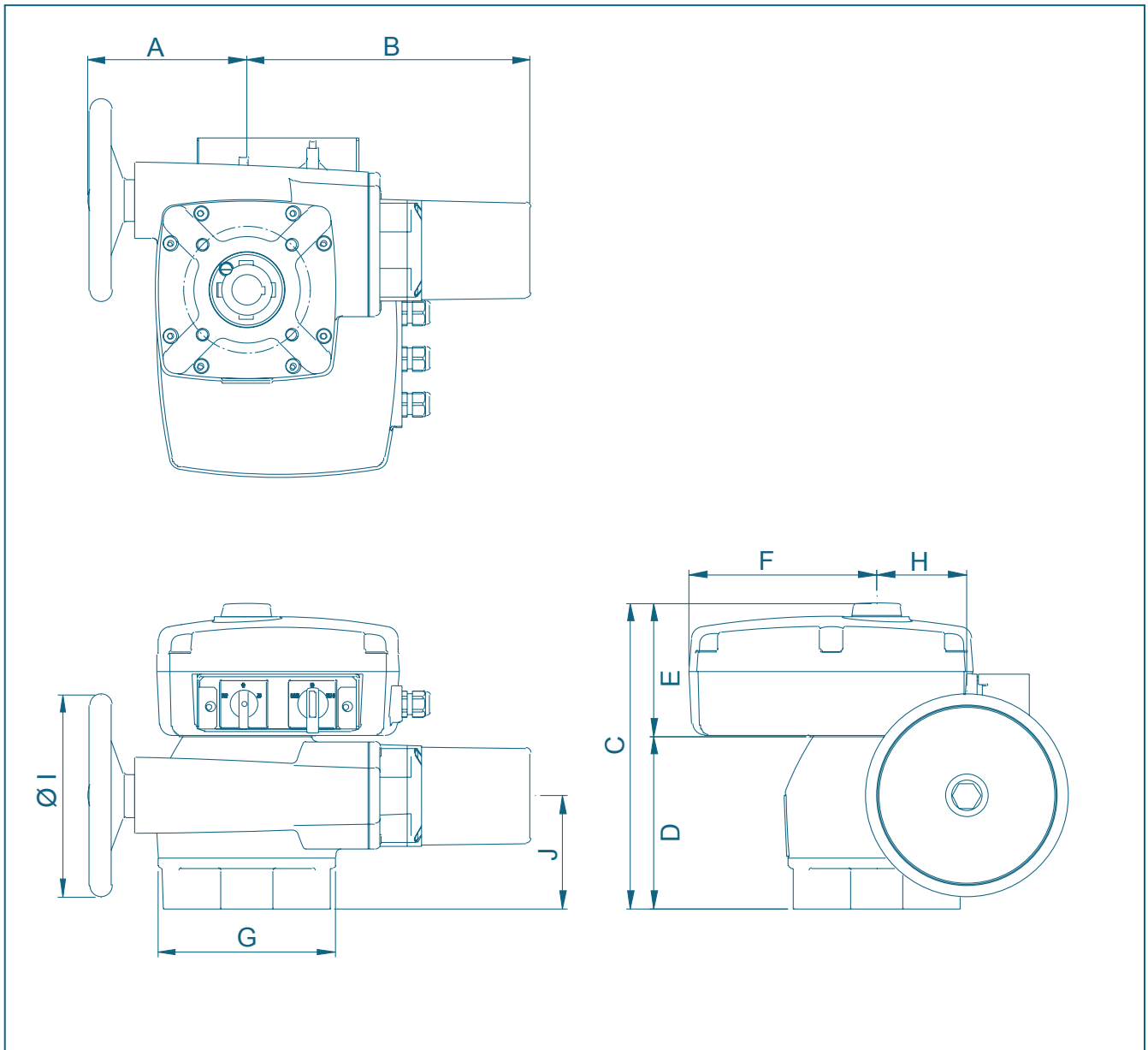

Type	Dimensions [mm]										Top flange
	A	B	C	D	E	F	G	H	ØI	J	
E 65	119	171	255	123	132	185	125	42	80	78	F04, F05, F07
E 110	136	247	277	145	132	190	150	58	125	88	F07, F10
E 160	157	280	302	170	132	185	175	89	200	112	F10, F12, F16
E 210	212	352	294	162	132	185	240	125	315	84	F12, F14, F16

Subject to change without notice

# MODULAR MOUNTING

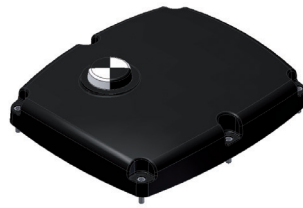

Body (upper part)

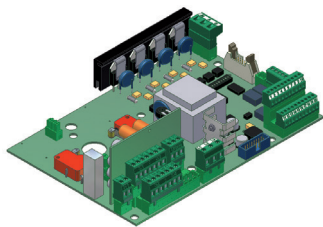
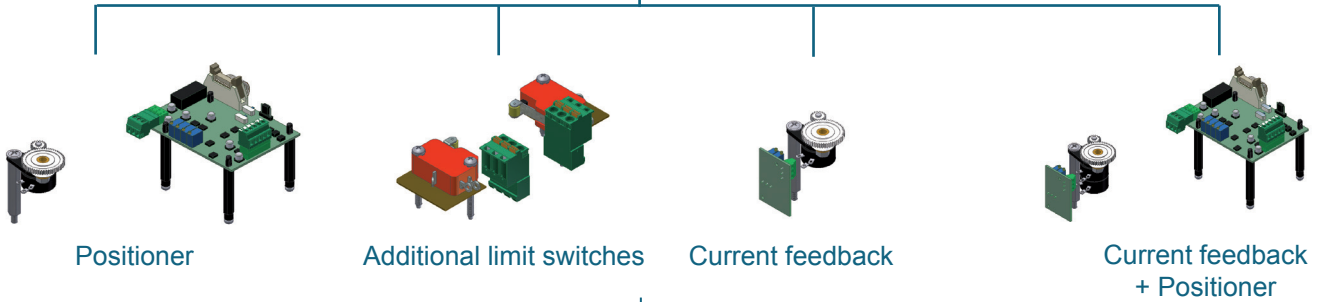

Main board three phase AC

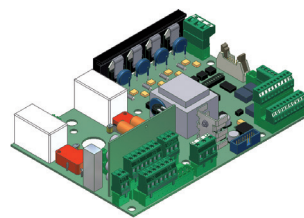

Main board AC

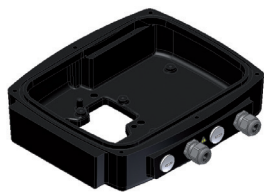

Body (lower part)

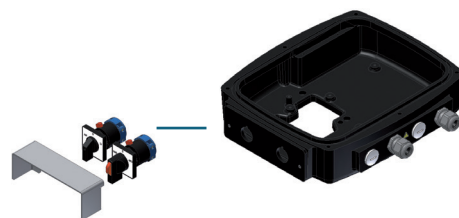

Body (lower part) with local control



E 65



E 110



E 160



E 210

# ORDER CODES

Order Code		Standard			Options			
		Main Board PI.E71-Local	Digital remote control inputs	Digital feedback	Additional Limit Switches	Current Feedback 4-20mA	Local control	Positioner PI.E71-POS
Alternating Current	Three-Phase Current							
M71-WS-001-40	M71-DS-001-40	X	X	X				
M71-WS-002-40	M71-DS-002-40	X	X	X	X			
M71-WS-003-40	M71-DS-003-40	X	X	X		X		
M71-WS-004-40	M71-DS-004-40	X	X	X			X	
M71-WS-005-40	M71-DS-005-40	X	X	X	X	X		
M71-WS-006-40	M71-DS-006-40	X	X	X		X	X	
M71-WS-007-40	M71-DS-007-40	X	X	X	X		X	
M71-WS-008-40	M71-DS-008-40	X	X	X	X	X	X	
M71-WS-009-40	M71-DS-009-40	X		X				X*
M71-WS-010-40	M71-DS-010-40	X		X	X			X*
M71-WS-011-40	M71-DS-011-40	X		X		X		X*
M71-WS-012-40	M71-DS-012-40	X		X			X	X*
M71-WS-013-40	M71-DS-013-40	X		X	X	X		X*
M71-WS-014-40	M71-DS-014-40	X		X		X	X	X*
M71-WS-015-40	M71-DS-015-40	X		X	X		X	X*
M71-WS-016-40	M71-DS-016-40	X		X	X	X	X	X*

\* If a positioner is installed, remote control information is disconnected

## Actuators with fail-safe position OPEN/CLOSE

Direct Current				
M71-GS-100-40	PI.E71-GS		X	without additional power charge unit for battery pack
M71-GS-200-40	PI.E71-GS		X	with additional power charge unit for battery pack

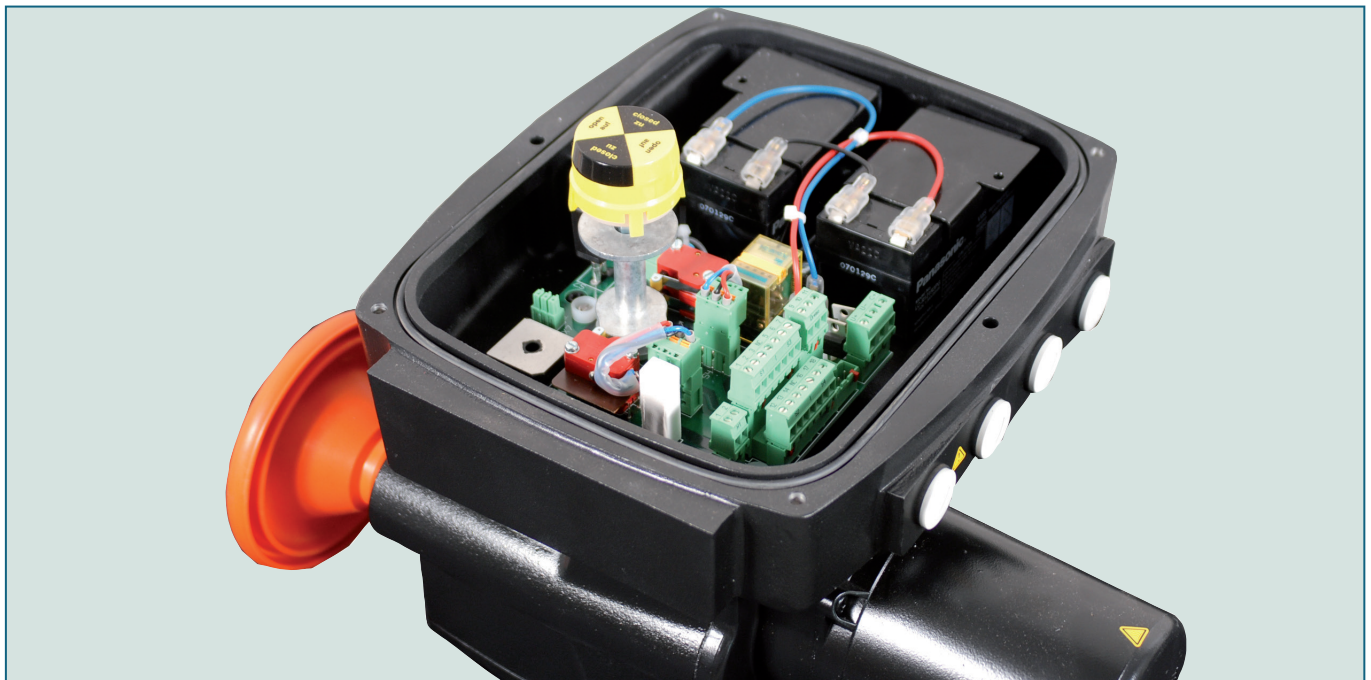

This version provides a safety position in case of power loss.