

Type: 2VExF(J)

Legend:

- | | | |
|-----------|---------------|-----------------------|
| 1- Nut | 5- Spring | 9- Body |
| 2- Washer | 6- Core guide | 10- Connector |
| 3- Coil | 7- Sealing | 11- Complete membrane |
| 4- Pin | 8- Core | |

Two way solenoid valves, normally closed

Application

Two way solenoid valves are used for control of water, air and other media, suitable for used materials. The valves are direct operated.

Technical data

Type	Version	Connection	Diameter DN[mm]	Operating Pressure [Mpa]	Flow Factor Kv [m3/h]	Fluid temperature Max [°C]	Seal	Voltage	Weight [kg]
2VE2F	N1	G1/4	2	0-3,0	0.125	90	NBR EPDM FPM	AC	0.36
	E2			0-2,5		110			
	F2			0-2,5		110			
2VE2FJ	N1	G1/4	2	0-2,0	0.125	90	NBR EPDM FPM	DC	0.36
	E2			0-1,6		110			
	F2			0-1,6		110			
2VE2,5F	N1	G1/4	2,5	0-1,8	0.18	90	NBR EPDM FPM	AC	0.36
	E2			0-1,6		110			
	F2			0-1,6		110			
2VE2,5FJ	N1	G1/4	2,5	0-1,4	0.18	90	NBR EPDM FPM	DC	0.36
	E2			0-1,0		110			
	F2			0-1,0		110			
2VE3F	N1	G1/4	3	0-1,4	0.25	90	NBR EPDM FPM EPDM	AC	0.36
	E2			0-1,0		110			
	F2			0-1,0		110			
	E3			0-0,6		130			
2VE3FJ	N1	G1/4	3	0-0,8	0.25	90	NBR EPDM FPM	DC	0.36
	E2			0-0,6		110			
	F2			0-0,6		110			
2VE4F	N1	G1/4	4	0-0,8	0.3	90	NBR EPDM FPM	AC	0.36
	E2			0-0,6		110			
	F2			0-0,6		110			
2VE4FJ	N1	G1/4	4	0-0,4	0.3	90	NBR FPM	DC	0.36
	F2			0-0,25		110			
2VE6F	N1	G1/4	6	0-0,2	0.6	90	NBR FPM	AC	0.36
	F2			0-0,15		110			
2VE6FJ	N1	G1/4	6	0-0,15	0.5	90	NBR FPM	DC	0.36
	F2			0-0,12		110			
2VE6DF	N1	G1/4	6	0,005-1,6	0.56	90	NBR EPDM EPDM	AC	0.36
	E2			0,005-1,6		110			
	E3			0,005-0,6		125			
2VE6DFJ	N1	G1/4	6	0,005-1,4	0.56	90	NBR EPDM	DC	0.36
	E2			0,005-1,0		110			

Materials:

Body.....brass
 Internal parts.....stainless steel
 Sealing.....NBR, EPDM, FPM
 Coil insulation class.....F

Installation

Clean pipeline system before installing valve. Dirt causes malfunction. If necessary, fit filter upstream of valve inlet. The valve will not open or close if the control ducts or the armature are blocked by dirt.

Avoid subjecting the valve housing to excessive stress through badly aligned tubing, use of unsuitable tools or sealing material.

Do not use solenoid as lever arm when installing.

The valve seals fully, in the direction of flow only. Flow against the direction of the flow-indicating arrow may cause damage to internal components.

The mounting position shall be held on recommendations of manufacturer. The preferred mounting position, "solenoid vertical": reduces the risk of wear and contamination.

Electrical connection

Connect the solenoid in accordance with National electrical Engineering Standards. After connection, protection must be ensured through careful alignment of the seal. Ensure effective sealing at the cable entry. The central screw of connector socket to be tightened with 60 Ncm max: no visible deformation of the housing should occur.

The earth lead must, without fail, be connected to the terminal designated for this purpose and marked accordingly.

Instruction for operation

Compare performance (type) label and product range table with the given operating conditions. The application limit values must not be exceeded.

Before pressurization a function test is recommended. A clicking noise should be audible when switching (impact of solenoid armature).

With fluids capable of freezing, the valves are not frost-proof.

Sealing and strength tests are permitted with open or closed valve. The following applies here: 1,5 x maximum operating pressure (see type label). The valve must not be switched during these tests.

Maintenance

Preventive maintenance, appropriate to the operating conditions and at significant changes of switching times, is recommended. Deposits, dirt, old or worn seals may lead to malfunction.

This includes the solenoid seals if protection is to be maintained.

Maintenance work must be carried out only in the absence of pressure in the paperwork (tubing) and with the solenoid disconnected from the supply voltage.

Upon request, we can supply brochures with sectional drawing and assembly instructions for wearing part kits.

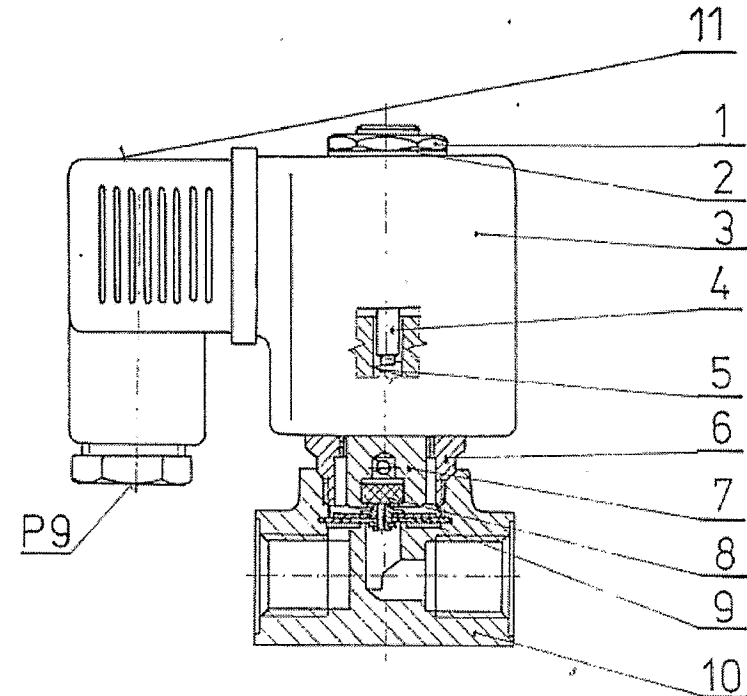

Type: 2VE6DF(J)