

OpenAir™

## Air damper actuators with spring return

GPC..1A



### Electric motor-driven rotary actuators for open-close, three-position and modulating control

- 4 Nm nominal torque
- Operating voltage AC 24 V ~ / DC 24...48 V = or AC 100...240 V ~
- Emergency function with spring return
- Prewired with 0.9 m connecting cable
- Position indication
- Auxiliary switches for auxiliary functions

## Features

The spring return actuator drives the damper to the desired operating position after connecting the operating voltage. At the same time, the spring return, integrated in the actuator, is tensioned. In the event of a loss of operational voltage, the spring return automatically drives the damper to the defined emergency position.

- Brushless, robust DC motors ensure reliable operation regardless of load.
- The damper actuators do not require an end position switch, are overload proof, and remain in place upon reaching the end stop.
- The gears are maintenance free and low noise.
- Simple and reliable shaft fixation.
- Mounting bracket included.

The spring preload of 5° ensures safe closure of the air dampers.

## Use

- Rotary actuator with spring return. Used on ventilation and air conditioning plants to operate air dampers that must be rotated to a defined emergency position during a power outage.
- For damper areas up to 0.6 m<sup>2</sup>, friction dependent.
- Suitable for use with modulating controllers (DC 0/2...10 V), open-close or three-position controllers.
- For directly driven zone dampers to control air flow in air ducts.
- We recommend a minimum pulse length of 500 ms on rotary actuators operated with 3-point control to ensure continuous and accurate operation.

## Functions

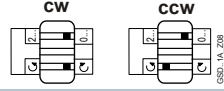
Type	AC 24 V ~ / DC 24...48 V =	GPC12..1A	GPC13..1A	GPC16..1A
	AC 100...240 V ~	GPC32..1A		GPC361.1A
Control type		Open-close	Three-position	Modulating control
Rotary direction		Clockwise (cw) or counter-clockwise (ccw) direction depends on the mounting position on the damper shaft ...		
			... on the type of control.	... on the type of control ... on the setting of the rotary direction DIL switch (cw / ccw)
				
Emergency function		In the event of a power outage or switching off operating voltage, the spring return drives the actuator and damper, connected by the damper shaft, to the defined emergency position.		
Position indication: Mechanical		Rotary angle position indication by a position indicator.		
Position indication: Electrical				<ul style="list-style-type: none"> <li>• Output voltage U = DC 0/2...10 V is generated proportional to the rotary angle.</li> <li>• U depends on the rotary direction of the DIL switch setting.</li> </ul>
Auxiliary switches		Fixed position 5° / 85°		

## Technical design/mechanical design

### Housing

The housing consists essentially of flame retardant, non brominated, non chlorinated glass fibre reinforced plastic.

## Type summary

Typ	Stock number	Control	Operating voltage	Position indicator U = DC 0/2...10 V	Aux. switches	Rotary direction switch	Aux. power supply DC 24 V (G+)
GPC121.1A	S55499-D233	Open-close	AC 24 V ~ / DC 24...48 V =	-	-	-	-
GPC126.1A	S55499-D234				2		
GPC131.1A	S55499-D235	-					
GPC136.1A	S55499-D236	Three- position		2	yes		
GPC161.1A	S55499-D237	Modulating		yes			
GPC166.1A	S55499-D238			2			
GPC321.1A	S55499-D239	Open-close	AC 100...240 V ~	-	-	-	
GPC326.1A	S55499-D240			2			
GPC361.1A	S55499-D241	Modulating		yes	-	yes	

## Product documentation

Topic	Title	Document ID
Data sheet	Air damper actuators with spring return GPC..1A	A6V10636100_en--
Mounting instructions	Rotary-type actuator GPC..1A	A6V10636095_----

Related documents such as environmental declarations, CE declarations, etc., can be downloaded at the following Internet address:

<http://siemens.com/bt/download>

## Notes

## Safety

	<b>⚠ Caution</b>
	<b>National safety regulations</b> Failure to comply with national safety regulations may result in personal injury and property damage. <ul style="list-style-type: none"><li>• Observe national provisions and comply with the appropriate safety regulations.</li><li>• Use only properly trained technicians for mounting, commissioning, and servicing.</li></ul>

## Engineering

### Auxiliary switches

Auxiliary switches cannot be added in the field.

## Installation

	<b>⚠ WARNING</b>
	<p><b>No internal line protection for supply lines to external consumers</b>            Risk of fire and injury due to short-circuits</p> <ul style="list-style-type: none"> <li>Adapt the line diameters as per local regulations to the rated value of the installed fuse.</li> </ul>

## Maintenance

The rotary actuators with spring return GPC..1A are maintenance-free.

## Disposal

	<p>The device is considered an electronics device for disposal in terms of European Directive 2012/19/EU and may not be disposed of as domestic garbage.</p> <ul style="list-style-type: none"> <li>Dispose of the device through channels provided for this purpose.</li> <li>Comply with all local and currently applicable laws and regulations..</li> </ul>
---	---

## Technical data

Power supply (GPC..1A)		
Operating voltage (SELV/PELV) / Frequency		AC 24 V ~ ±20 % (19.2...28.8 V ~) / 50/60 Hz DC 24...48 V = ±20 % (19.2...57.6 V =) <sup>1)</sup>
Power consumption running	GPC12..1A GPC13..1A	4.3 VA / 2.7 W
	GPC16..1A	3.7 VA / 2.2 W
Power consumption holding	GPC12..1A GPC13..1A	2.6 VA / 1.5 W
	GPC16..1A	2.7 VA / 1.5 W
Power supply (GPC3..1A)		
Operating voltage / Frequency		AC 100...240 V ~ ±10 % (90...264 V ~) / 50/60 Hz
Power consumption running	GPC32..1A GPC361.1A	6.9 VA / 2.9 W 6.7 VA / 2.9 W
	GPC32..1A GPC361.1A	4.8 VA / 1.9 W 4.5 VA / 1.8 W
Power consumption holding		
Functional data		
Nominal torque		4 Nm
Nominal rotational angle		90°
Maximum rotational angle (mechanically limited)		95° ± 2°
Runtime at nominal rotational angle 90°		60 s
Closing time with return spring (on power failure) 90°		15 s
Duty cycle		100 %
Direction of rotation		Clockwise / counterclockwise
Mechanical life		100 000 cycles
Sound power level	Actuator	40 dB(A)
	Spring return	60 dB(A)

Inputs	
Positioning signal for GPC12..1A Operating voltage (wires 1-2/G-G0) AC 24 V ~ / DC 24...48 V = / 0 V	open / close
Positioning signal for GPC32..1A Operating voltage (wires 3-4/L-N) AC 100...240 V ~	open / close
Positioning signal for GPC13..1A Operating voltage (wires 1-6/G-Y1) AC 24 V ~ / DC 24...48 V = (wires 1-7/G-Y2) Switching current	open close typically 8 mA
Positioning signal for GPC16..1.A Input voltage (wires 8-2/Y-G0) Current consumption Input resistance Max. permissible input voltage	DC 0/2...10 V = 0.1 mA >100 kΩ DC 35 V
Outputs	
Position indicator Output signal (GPC16..1.A) (wires 9-2/U-G0) Output signal (GPC361.1.A) (wires 9-2/U-G-) Output voltage U Max. output current Protected against faulty wiring Aux. power supply (GPC361.1A) (wires 1-2/G+-G-)	DC 0...10 V = DC ±1 mA max. AC 24 V ~ / DC 24...48 V = DC 24 V = ±20 %, max. 10 mA
Auxiliary switches	
Switching voltage Contact rating  Electric strength auxiliary switches against housing Factory switches setting: Switch A / Switch B Mixed operation (AC 24 V ~ / DC 24...48 V = and AC 100...240 V ~) is not permissible.	AC 24...250 V ~ / DC 12...30 V = 6 A resistive, 2 A inductive, min. 10 mA @ AC 4 A resistive, 2 A inductive, min. 10 mA @ DC 30 V = 0.8 A res., 0.5 A inductive, min. 10 mA @ DC 60 V = AC 4 kV 5° / 85° (fixed position)
Connection cables	
Cable length	0.9 m
Cross-section	0.75 mm <sup>2</sup>
Degree of protection	
Insulation protective class AC 24 V ~ / DC 24...48 V = AC 100...240 V ~	As per EN 60730 III II
Housing protection	IP54 as per EN 60529
Environmental conditions	
Operation – Climatic conditions – Mounting location – Temperature (extended) – Humidity, non-condensing	IEC 60721-3-3 Class 3K5 Interior, weather-protected -32...+55 °C <95 % r.F.
Transportation – Climatic conditions – Temperature (extended) – Humidity, non-condensing	IEC 60721-3-2 Class 2K3 -32...+70 °C <95 % r.F.
Storage – Climatic conditions – Temperature (extended) – Humidity, non-condensing	IEC 60721-3-1 Class 1K3 -32...+50 °C <95 % r.F.
Mechanical conditions	Class 3M3

Standards, directives and approvals	
Product standard	EN 60730 Part 2-14 / Particular requirements for electric actuators
Electromagnetic compatibility (Applications)	For use in residential, commerce, light-industrial and industrial environments
EU Conformity (CE)	A5W00029693 <sup>2)</sup>
RCM Conformity	A5W00029694 <sup>2)</sup>
EAC Conformity	Eurasian conformity
UL	UL <sup>1)</sup> according UL 60730 <a href="http://ul.com/database">http://ul.com/database</a> cUL <sup>2)</sup> according CSA-C22.2 No. 24-93

#### Environmental compatibility

The product environmental declaration A5W00030347-A<sup>3)</sup> contains data on environmentally compatible product design and assessments (RoHS compliance, materials composition, packaging, environmental benefit, disposal).

#### Dimensions

Actuator W x H x D	See "Dimensions" p. 9
Damper shaft	
round	8...15 mm
Square	6...11 mm
Min. shaft length	20 mm
Shaft hardness	<300 HV

#### Weight

Excl. packaging	Max. 0.55 kg, without switches Max. 0.8 kg, with switches
-----------------	--

<sup>1)</sup> Safety low voltage actuators without switches

<sup>2)</sup> Safety low voltage actuators without switches max. DC 30 V =

<sup>3)</sup> The documents can be downloaded from <http://siemens.com/bt/download>.

## Diagrams

### Internal Diagrams

GPC12..1A (Open / close)

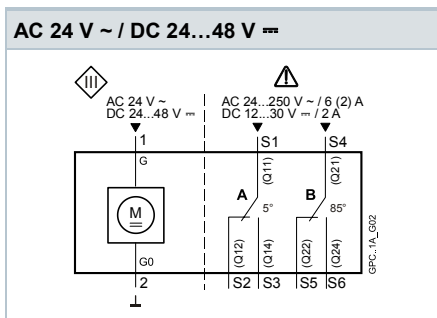

GPC32..1A (Open / close)

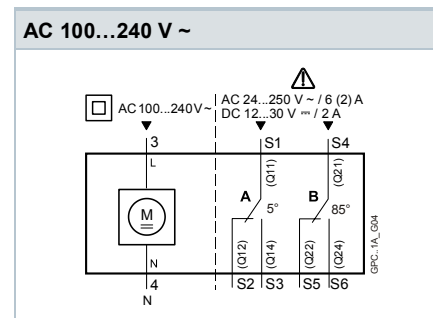

GPC13..1A (Three-position)

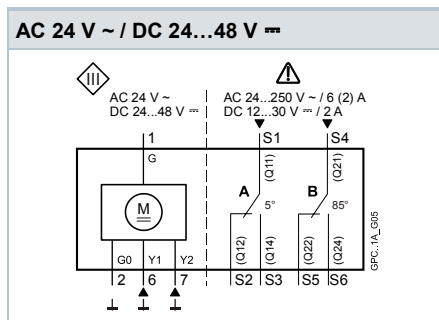

GPC16..1A (Modulating control)

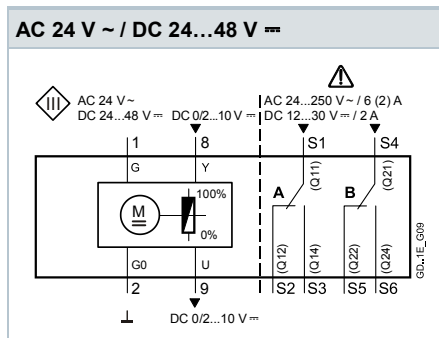

GPC361.1A (Modulating control)

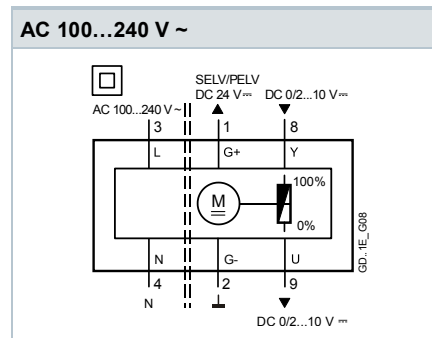

Connection diagrams

GPC1..1A (AC 24 V ~ / DC 24...48 V =)

Open-close control	Three-position control	Modulating control

## GPC3..1A (AC 100...240 V ~)

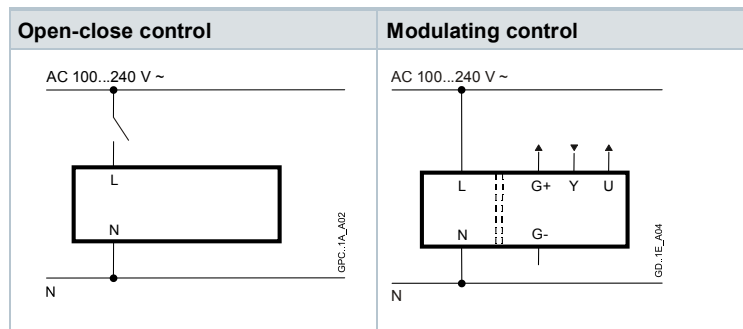

## Cable labeling

Connection	Cable				Meaning
	Code	No.	Color	Abbreviation	
Actuators AC 24 V ~ DC 24...48 V =	G	1	red	RD	System potential AC 24 V ~ / DC 24...48 V = System neutral Pos. signal AC/DC 0 V, AC 24 V ~ / DC 24...48 V =, "open" (GPC13..1A) Pos. signal AC/DC 0 V, AC 24 V ~ / DC 24...48 V =, "close" (GPC13..1A) Signal in (GPC16..1A) Signal out (GPC16..1A)
	G0	2	black	BK	
	Y1	6	purple	VT	
	Y2	7	orange	OG	
	Y	8	grey	GY	
Actuators AC 100...240 V ~	U	9	pink	PK	Line AC 100...240 V ~ Neutral conductor System potential DC 24V = (GPC361.1A) System neutral (GPC361.1A) Signal in (GPC361.1A) Signal out (GPC361.1A)
	L	3	brown	BN	
	N	4	light blue	BU	
	G+	1	red	RD	
	G-	2	black	BK	
Auxiliary switch	Y	8	grey	GY	Switch A input Switch A normally closed contact Switch A normally open contact Switch B input Switch B normally closed contact Switch B normally open contact
	U	9	pink	PK	
	Q11	S1	grey/red	GY RD	
	Q12	S2	grey/blue	GY BU	
	Q14	S3	grey/pink	GY PK	
	Q21	S4	black/red	BK RD	
Q22	S5	black/blue	BK BU		
Q24	S6	black/pink	BK PK		



## Dimensions

