

8. Spare parts

Spare parts are not a part of the delivery. Required spare parts can be ordered stating the type of the device, the name and the position of the part according to the figure, and the number of pieces.

The product was tested by the producer according to the valid technical documentation. Warranty is granted according to the purchase agreement. In case of any fault it is necessary to contact the producer who arranges under-guaranty, after-guaranty repair or sends a spare part.

9. Liquidation of Product and Its Package

Parts of the product and its package can be used after dismantling and separation by the material as a source of secondary raw material. The product itself is not a source of environment pollution and do not contain any dangerous waste.

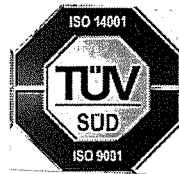

INSTALLATION, SERVICE AND MAINTENANCE INSTRUCTIONS

Reduction valve
Type: R6A, R3/8, R1/2

1. Application

The reduction valves are designed to keep constant outlet air pressure not depending on flow or input pressure changes.

2. Specifications

Flowing medium.....	pressed air
Maximum inlet pressure.....	1.6 MPa
Outlet pressure ¹⁾	0.05 MPa - 1 MPa
.....	0.05 MPa – 0.63 MPa
.....	0.02 MPa – 0.4 MPa
Connecting thread	
R6A	G1/4
R3/8	G3/8
R1/2	G1/2
Thread for pressure meter	M12 x 1,5
Ambient and flowing medium temperature.....	from + 5 °C up to + 60 °C

¹⁾ According to the data placed on the nameplate.

3. Description and Functioning ²⁾

The reduction valves consist of the following main parts: the body (1), the spring chamber (6), the regulating handle (2). The regulating screw (8) with a nut and the regulating spring (4) are placed in the spring chamber. The piston with the sealing (9) are mounted into the lower part. The membrane (7) is mounted between the body and the spring chamber.

The pressure regulation functions on the principle of interaction of forces effecting the membrane: prestress of the spring on one side and the outlet pressure on the other. The difference of the forces is transferred through the rod fixed with the membrane to the piston seat cover. The piston opens or closes the flow with the reduction valve according to size and sense of interaction of the both forces.

²⁾ On the figure the R6A type is shown, the R3/8 and R1/2 types are functionally the same and of similar design.

4. Mounting

The reduction valves are mounted onto or into the piping in any position. For fixing use connecting parts according to the catalogue or holes and threads of the body. The air flow direction has to be in accordance with the arrow placed on the body. If the device is delivered without a pressure meter one of the two end-seals can be unscrewed with a screw-wrench No. 6 and a pressure meter can be screwed into.

Inlet and outlet can be connected with couplings for plastic hoses or metal threaded tubes.

A filter with filtrating ability of min 55 mm is to be mounted ahead of the reduction valve.

5. Putting into Operation

Loosen the regulating spring using the regulating handle, and check connecting and mounting before starting of pressure air supply.

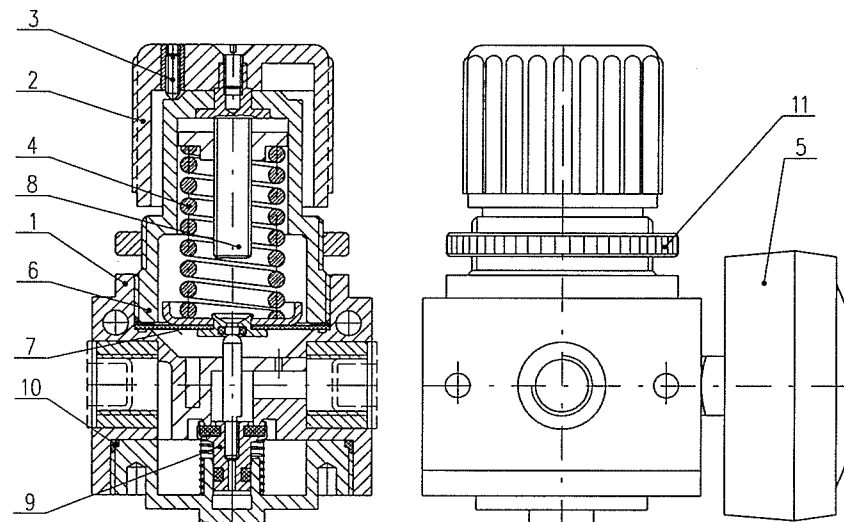

Legend:

- | | |
|-----------------------|--------------------------|
| 1..... body | 7..... complete membrane |
| 2..... handle | 8..... regulating screw |
| 3..... locking screw | 9..... complete piston |
| 4..... spring | 10..... sealing ring |
| 5..... pressure meter | 11..... rotating nut |
| 6..... spring chamber | |

6. Service

The required value of outlet pressure is to be adjusted with the regulating handle (2). In case of the R6A type loosen the locking screw (3), on the R3/8 or R 1/2 types pull up the handle in the direction of device's axis, before manipulating with the handle. Turning the handle following the arrow with the mark "+" the pressure is increasing, following the arrow with the mark "-" the pressure is decreasing. After adjusting of the required pressure which can be checked on the pressure meter screw the locking nut on the R6A type, on the R3/8 or R 1/2 types press the handle down towards the body, what arranges the arrestment. In case that during the adjustment of the outlet pressure the required value was exceeded, the pressure can be decreased with the handle (the regulating part is equipped with a relief valve) and the pressure is to be adjusted again.

CAUTION: The device is designed for operation at the outlet pressure stated on the nameplate. If it is adjusted to the higher value the regulation reliability can be decreased, as well as lifetime of the regulating spring, eventually the spring can be destroyed and this way the regulating function failed. The inlet pressure must be always higher than outlet.

7. Maintenance

Maintenance and repairs can be performed only with no air pressure supply.

If the device is during the maintenance dismantled, the internal parts should be cleaned, sealing checked, functioning parts lubricated, and after mounting the function should be checked.

Maintenance and repairs can be performed only by authorised personnel.

If the device is stopped working for longer time loosen the regulating nut (4).