

Fig. 2: Lubricator M6

INSTALLATION, SERVICE AND MAINTENANCE INSTRUCTIONS

Lubricator Type: M6, M3/8, M1/2

8. Spare parts

Spare parts are not a part of the delivery. Required spare parts can be ordered stating the type of the device, the name and the position of the part according to the figure, and the number of pieces.

The product was tested by the producer according to the valid technical documentation. Warranty is granted according to the purchase agreement. In case of any fault it is necessary to contact the producer who arranges under-guaranty, after-guaranty repair or sends a spare part.

9. Liquidation of Product and Its Package

Parts of the product and its package can be used after dismantling and separation by the material as a source of secondary raw material. The product itself is not a source of environment pollution and do not contain any dangerous waste.

1. Application

The lubricators for pressed air are designed for supply of regulated amount of lubricator into the air stream.

2. Specifications

Parameter	Type		
	M6	M3/8	M1/2
Max. operation pressure [MPa]	1	1	1
• with bowl without cover	-	1.6	1.6
• with bowl with cover	-	1.6	1.6
Connecting thread	G1/4	G3/8	G1/2
Useful capacity of bowl [cm ³]	91	120	
Operation temperature range [°C]	+5 ☉ +60		
Recommended oil type	bearing, permanent turbine, low-freezing Kinematical viscosity max.46 mm ² .s ⁻¹ at temperature of 40 °C		

3. Description and Functioning

The lubricator for air treatment consists of the body (1) and the bowl for oil (2). The main channel created in the body for the pressure air flow has got its middle part of the Venturi tube shape.

The pressed air flowing from the inlet throat through the Venturi tube (in the M6 lubricator) or the flexible element (in the M3/8 and M1/2 lubricators) soaks because of the difference of pressures the oil from the bowl. The oil flows then by the throttle needle (3) into the area covered with a transparent cover (4). From here it drops into the space of flowing air which sprays it and carries from the lubricator. The amount of oil supply can be controlled with the throttle needle.

4. Mounting

The lubricators are mounted onto or into the piping in vertical position – the bowl placed down. For fixing use connecting parts according to the catalogue or cross holes of the body. Inlet and outlet can be connected with couplings for plastic hoses or metal threaded tubes.

5. Putting into Operation

Check connecting and oil level in the bowl before starting of pressure air supply.

6. Service

The required value of oil supply is to be adjusted with the throttle needle (2).. Turning the needle following the arrow with the mark "+" lubrication intensity is increasing, following the arrow with the mark "-" lubrication intensity is decreasing. The oil refilling can be performed through the filling hole closed with the cap (6). While refilling that can be realised also during operation (under pressure) it is necessary to loosen the cap of the filling hole to have the bowl vented and then the cap fully unscrew. Having the cap screwed again the lubrication automatically starts. Oil can be filled up to the mark determining maximum level.

In case of proper connection into the pneumatic loop and operation according to specifications the lubricator requires no service. It is necessary to check oil level in the bowl to keep it against dropping under the mark of minimum value.

7. Maintenance

In case of long term operation sediments can be created on the bottom of the bowl. They are to be removed with unscrewing the bowl and cleaning it. For cleaning standard detergents can be used, do not use solvents as acetone, ammonia, lye etc. Maintenance and repairs of the pneumatic elements can be performed only by authorised personnel and with no air pressure supply.

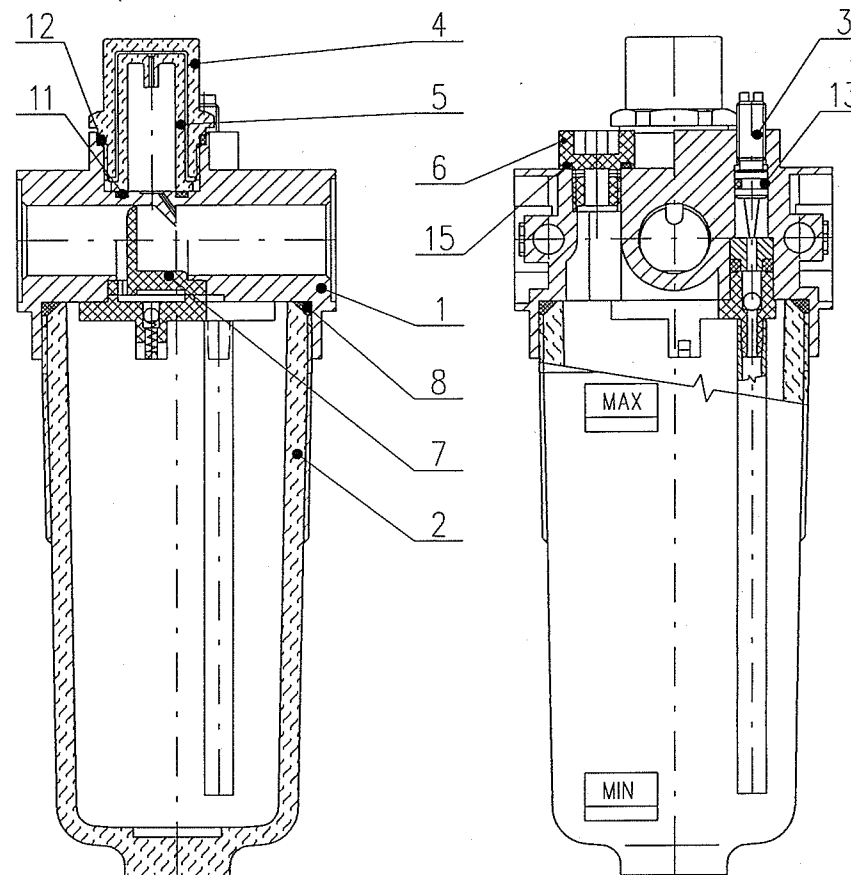

Fig. 1: Lubricators M3/8 and M1/2

Legend:

- 1 Body
- 2 Bowl
- 3 Throttle needle
- 4 External cover
- 5 Internal cover
- 6 Closing cap
- 7 Flexible element
- 8 Sealing ring
- 9 Membrane
- 10 Nut
- 11 Sealing ring
- 12 Sealing ring
- 13 Sealing ring
- 14 Sealing ring
- 15 Sealing ring