

# Goulds 3299

Heavy-duty Lined Chemical Pumps



**ITT**

**avrorarm.ru**  
**+7 (495) 956-62-18**

*Engineered for life*



# Model 3299 Heavy Duty Lined Chemical Pumps

Design Features for Wide Range of High Temperature/High Pressure Services

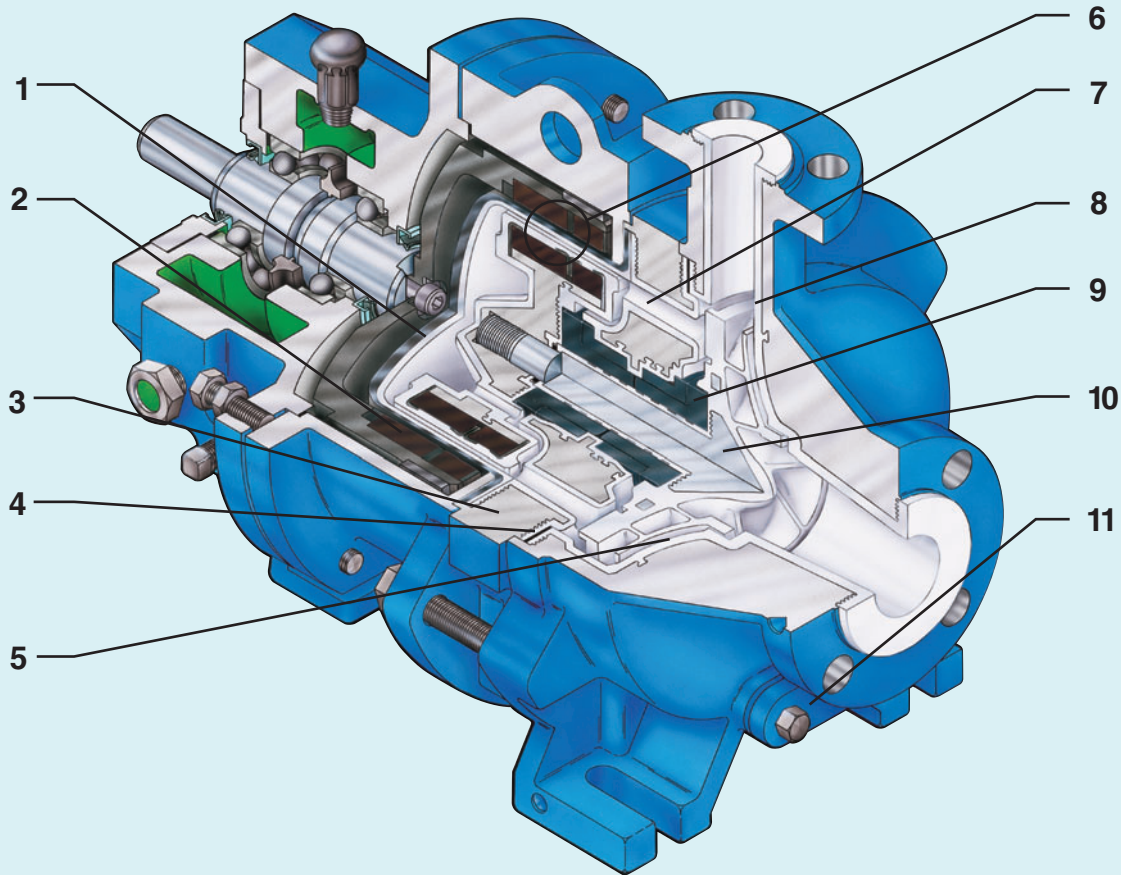

## ANSI DIMENSIONS

Allow easy retrofit of problem ANSI pumps

## VIRGIN PFA LINED DUCTILE IRON CONSTRUCTION

Provides superior corrosion resistance; inert to most chemicals. Temperatures to 360°F (182°C).

### (1) CONTAINMENT SHELLS

PTFE lining with carbon fiber reinforced plastic outer shell. Optional bonded shells for added safety on vacuum services. Non-metallic construction eliminates heat generated by eddy current losses common in metallic designs. 30% higher efficiencies than magnetic drive pumps with metallic containment shells.

### (2) FULLY ENCAPSULATED OUTER MAGNETS

Provide protection from the environment and ease cleaning of magnet assembly.

### (3) HEAVY DUTY ONE-PIECE BEARING CARRIER

PFA lined ductile iron carries all bearing loads.

### (4) FULLY CONFINED PTFE CASING GASKET

Provides superior corrosion resistance with reliable sealing performance.

### (5) PFA LINING WITH DUCTILE IRON CASING

One-piece solid casing lined with minimum 3/16" (4 mm) transfer molded PFA. Ensures lining integrity, longer life and decreased maintenance costs

### (6) RARE EARTH MAGNETS

High-strength Neodymium Iron Boron drive and Samarium Cobalt driven assemblies, provide high torque and hard start capability without slipping. Synchronous drive. Optional Samarium Cobalt drive magnets provide additional margin of safety for high temperature services.

### (7) RECIRCULATION CIRCUIT

Large internal passages provide better solids handling and recirculation flow for increased reliability and reduced risk of plugging.

### (8) TRANSFER MOLDED CASING

Proprietary process ensures uniform thickness of lining throughout casing. Produces consistent lining integrity needed for severe services.

### (9) DRYGUARD™ SILICON CARBIDE BEARINGS

Provide optimum dry-run protection and the ultimate in corrosion and abrasion resistance.

### (10) ONE-PIECE SHAFT AND IMPELLER ASSEMBLY

Enclosed impeller minimizes axial thrust. PFA lined 316 stainless steel shaft and impeller core provide increased mechanical strength while retaining corrosion resistance.

### (11) OPTIONAL DRAIN CONNECTION

Allows easier draining and flushing of unit.

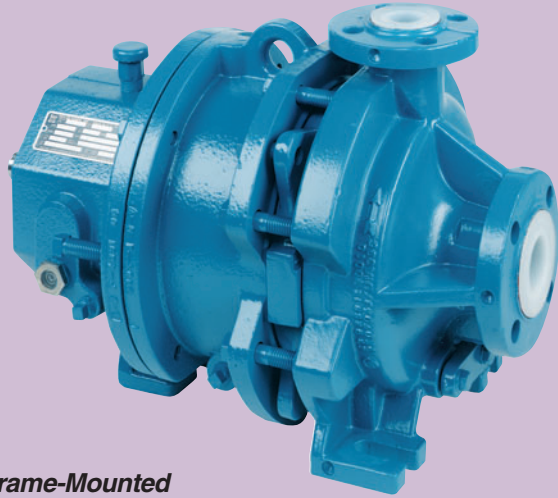

*Frame-Mounted*

The 3299 is designed specifically to handle corrosives that require the universal corrosion resistance of Virgin PFA. As a sealless design, it's an effective alternative to pumps with mechanical seal problems. Meets strictest EPA regulations.

The standard frame mounted configuration provides rugged dependable service for the most severe applications.

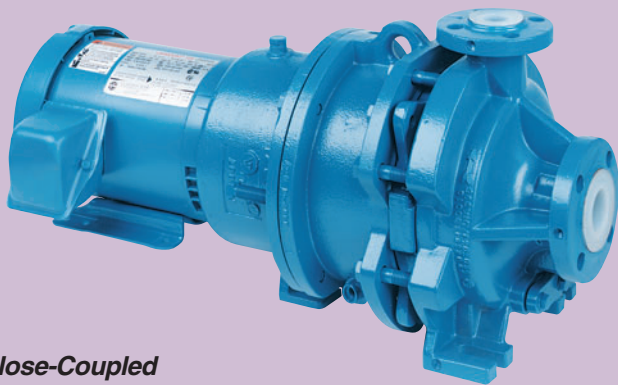

*Close-Coupled*

# Goalds Model 3299

## Heavy Duty Lined Pumps for Chemical Services

- Capacities to 425 GPM (95 m<sup>3</sup>/h)
- Heads to 490 feet (149 m)
- Temperatures to 360°F (180°C)
- Pressures to 275 PSIG (1896 kPa)

## Performance Features for Chemical Services

### Extended Pump Life

- Virgin PFA Construction
- Sealless Design
- PFA Lined Solid 316 Stainless Steel Shaft
- Dryguard™ Bearings

### Optimum Performance

- Non-slip Synchronous Drive with Neodymium Iron Boron Outer Magnets and Samarium Cobalt Inner Magnets
- Optional Samarium Cobalt Outer Magnets
- Efficiency Equivalent to Sealed ANSI Pumps, 30% Higher than Metal Sealless Pumps

### Ease of Maintenance

- Minimum Parts
- ANSI Dimensional
- Optional Close-Coupled Design
- No Mechanical Seal

### Safety

- Drive Magnet Assembly Bump Ring
- Adapter Drain Connection
- Optional Casing Drain
- Zero Emissions

## Services

- Hot Acids
- Nitric Acid
- Acetic Acid
- Amines
- Chlorinated Solvents
- Carbon Tetrachloride
- Chloroform
- Dichloroethylene
- Freon 113
- Ethers
- Acetone
- Bromine
- Hydrofluoric Acid
- Chlorine Dioxide
- Sodium Hypochlorite

# Model 3299

# Heavy Duty Lined Chemical Pump

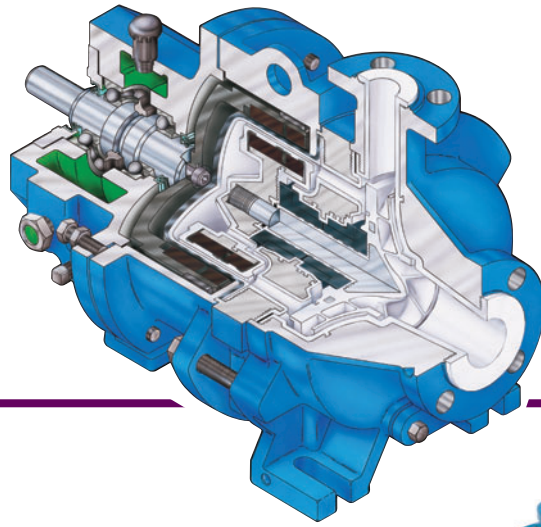

## PFA Construction for Universal Corrosion Resistance to 360°F (182°C)

Virgin PFA® is virtually inert to all chemicals and has excellent permeation resistance. PFA lined casing, bearing carrier, and one-piece impeller/shaft assembly provide superior corrosion resistance and long life, unequalled by alloy pumps.



## Non-Sparking Rub Ring

Assures containment shell integrity in the unlikely event of a ball bearing failure. Provides safe support of drive carrier in the clamp ring during assembly and disassembly.



## Designed for Safe Operation

### DUAL CONTAINMENT SHELL

PTFE lining with carbon fiber reinforced plastic (CFRP) shell. Non-metallic construction provides efficiencies the same or better than sealed ANSI pumps; 30% higher efficiencies than metal sealless pumps. Non-metallic construction eliminates magnet losses and heat generation. CFRP shell provides rigid support for the liner and acts as a secondary method of containment should the primary liner fail.



## Integral Shaft and Impeller

Enclosed design minimizes axial thrust, extends thrust bearing life. One-piece construction eliminates front shroud failures possible with two-piece impellers. Large metal core improves mechanical strength. Integral PFA lined shaft and impeller optimizes corrosion resistance, strength, and durability of a stainless steel shaft, eliminating the chances of stress fractures associated with silicon carbide shafts.



## Solids Handling

Standard large internal clearances allow the passage of solids up to 0.06 inches with a maximum concentration of 2%. Concentrations of up to 10% and sizes up to 0.1875 inches in diameter can be pumped with the External Bearing Flush option offered by Goulds Pumps.

## High Pressure Capability

The ductile iron casing and adapter with the carbon fiber reinforced containment shell are designed for pressure containment to 275 PSIG. The PFA lining resists permeation of the most corrosive materials in high pressure applications.

# Exceptional Performance for Chemical Services

## Dry Run Protection with Dryguard™

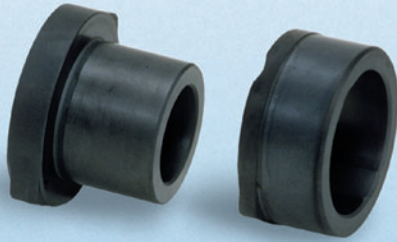

### DRYGUARD™ BEARINGS AND SHAFT

Goulds unique Dryguard™ diamond-like carbon coating provides extra protection for the silicon carbide bearings, allowing the pump to withstand tough conditions and system upsets. If your system cannot guarantee fluid 100% of the time, Goulds recommends Dryguard™.



### PUMP LOAD MONITORS

The PS10 and PS20 Pump Load Monitors measure the motor input power in combination with a proprietary algorithm to accurately determine the pump's load.

During dry-run conditions, pump power is reduced and recognized by the PumpSmart Pump Load Monitor. During run-out conditions, power increases, which is also a recognizable condition. Power increase is also experienced when internal war results from upset conditions. Customers may configure the devices to automatically shutdown the pump or warn the operator via integrated relay output(s).

#### PS10 Pump Load Monitor

The PS10 offers single underload or overload condition protection for pumps up to 40 HP (50 Amps MAX). Alarm setpoints can be entered either manually or automatically set using the Auto-set functionality during normal operation.

#### PS20 Pump Load Monitor

The PS20 offers single underload or overload condition protection for pumps up to 40 HP (50 Amps MAX). Alarm setpoints can be entered either manually or automatically set using the Auto-set functionality during normal operation.

## Ultimate Protection

Magnetic drive pump failures are often due to dry running and closed discharge valve conditions. With Dryguard™ silicon carbide bearings and a power monitor, you have the best protection technology can offer. Goulds always recommends the use of a power monitor because... **FAILURE IS NOT AN OPTION!**

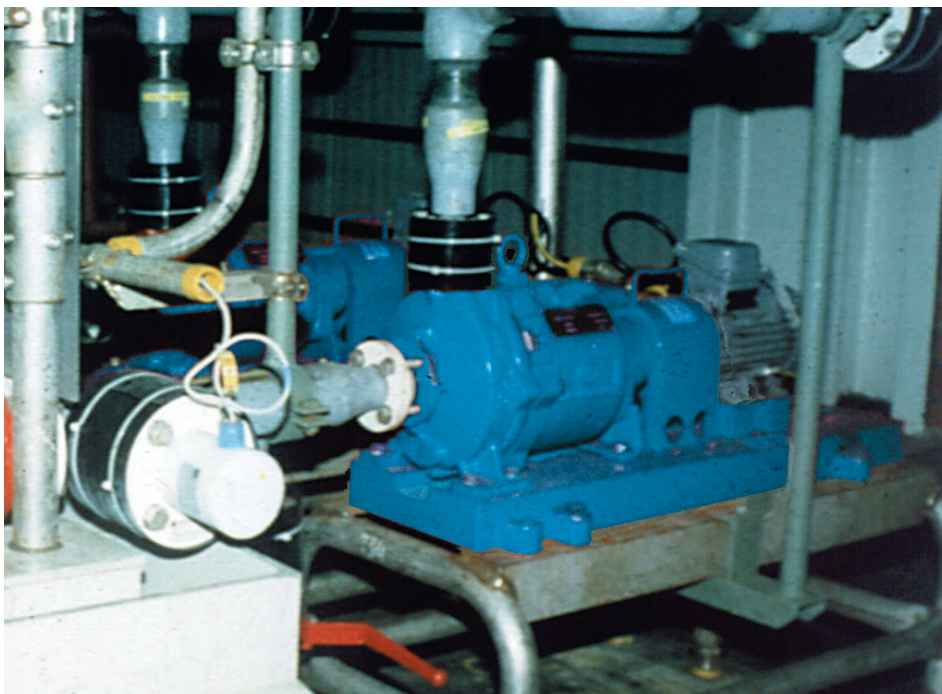

## Zero Leakage on Hard to Seal Hot Corrosives

The 3299 is sealless and environmentally safe. No mechanical seal assures zero leakage on moderate to severe corrosives and hazardous liquids. A great solution to a pump with mechanical seal problems.

# Heavy Duty Design/Reliable Operation

## Design Features for Extended Pump Life

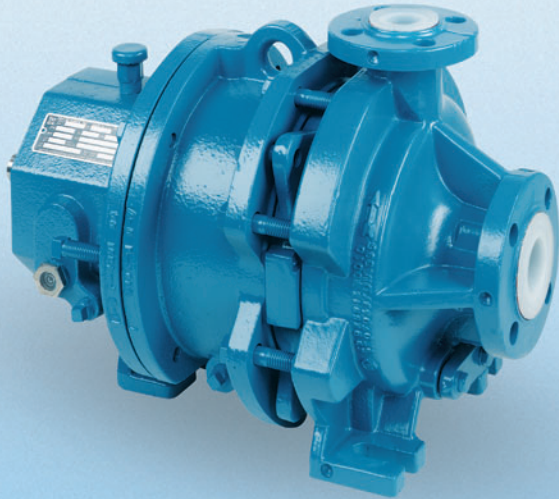

### Tough Armored Casing

Ductile iron casing, adapter, and bracket provide rugged, dependable service in the most severe applications. Designed for pressure up to 275 PSIG (1896 kPa) and temperatures to 360°F (182°C).

### Fully Confined PTFE Casing Gasket

Reliable sealing compatible with the pumped fluid without the worry of gasket blowout.

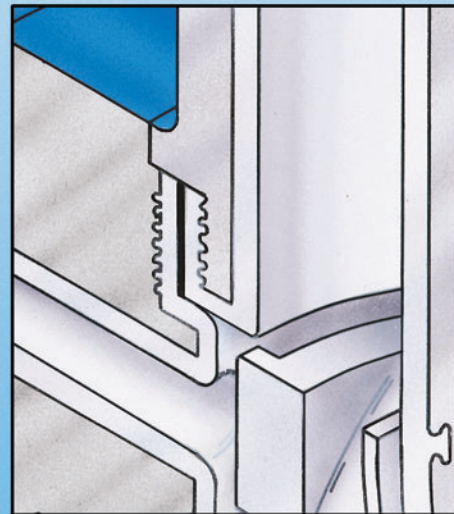

## Installation Flexibility

The 3299 is available in frame-mounted or close-coupled designs for true installation or pump replacement flexibility.



### ANSI Pump Replacement

Since the 3299 meets ANSI dimensional standards, retrofitting mechanically sealed ANSI pumps is easy: simply replace the old pump with the equivalent frame-mounted or close-coupled ANSI size 3299.

# Hydraulic Coverage

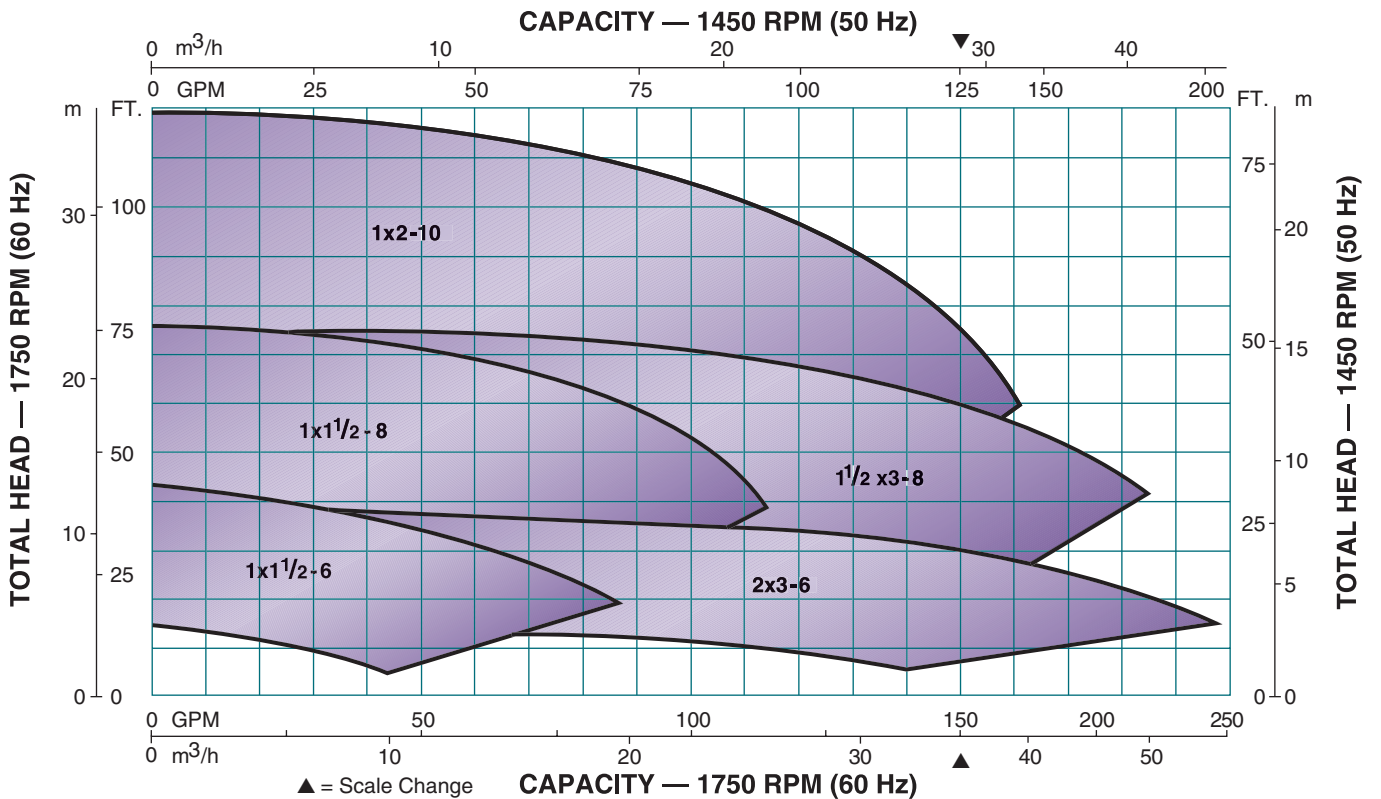
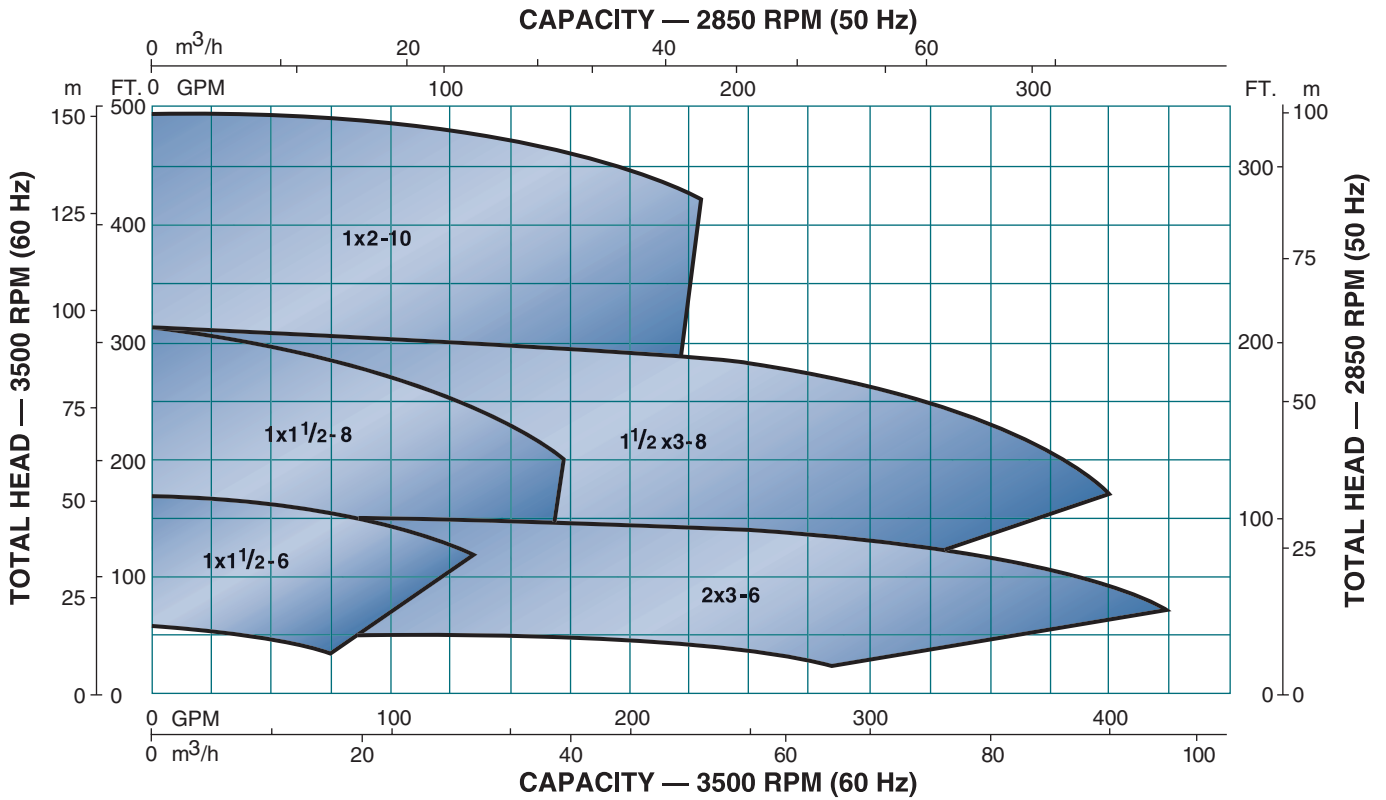

# Modular Interchangeability

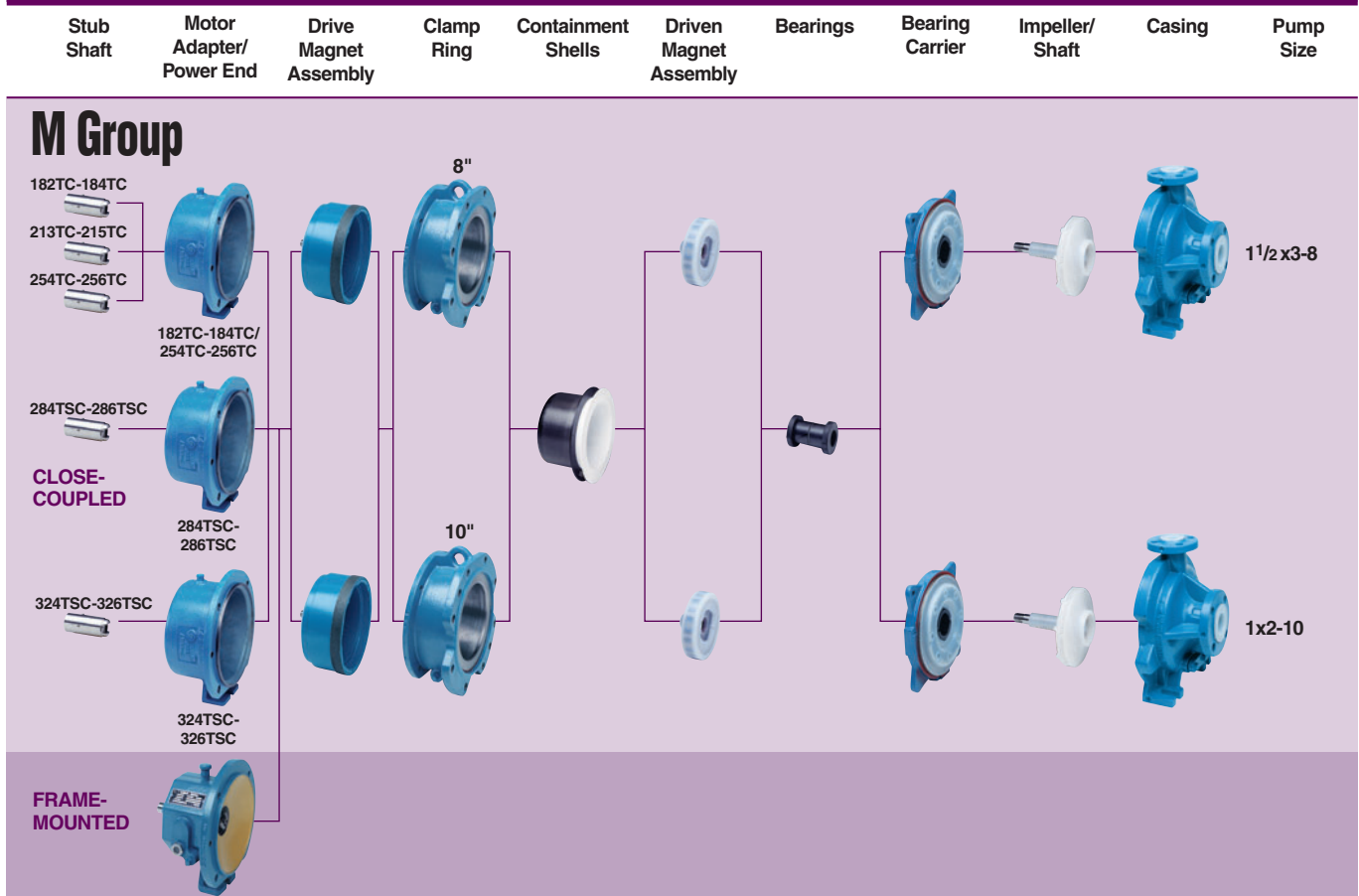
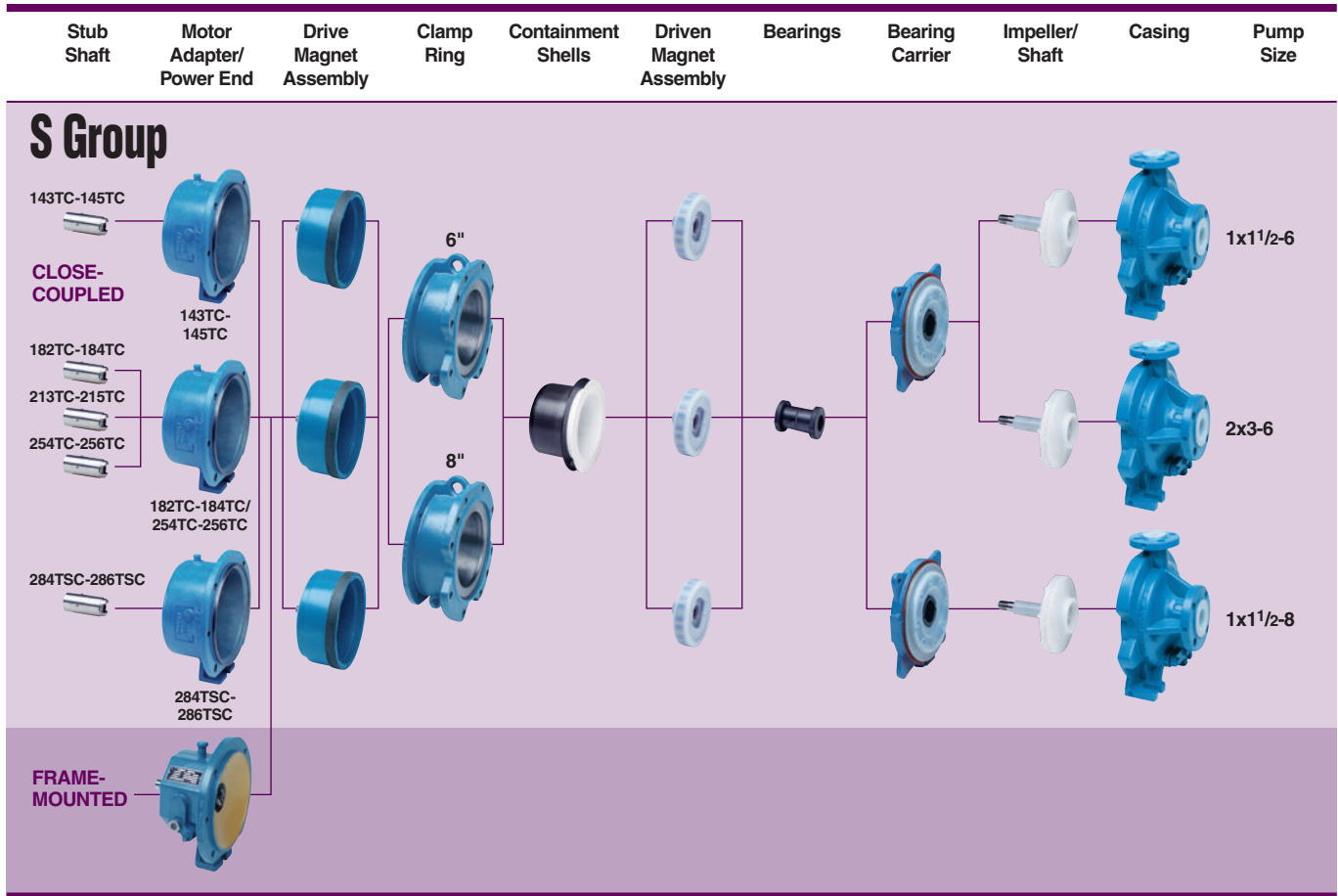



# Sectional View Model 3299

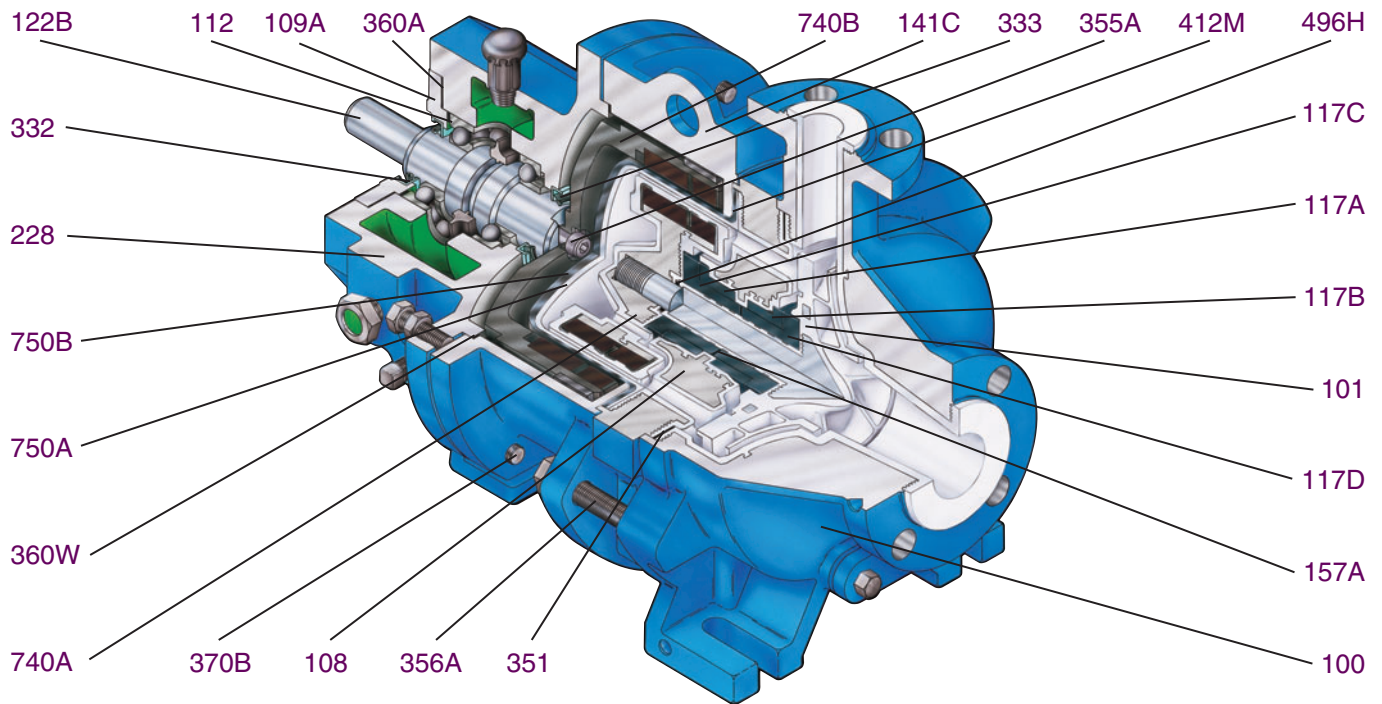

## Parts List and Materials of Construction

Item Number	Part Name	Material
100	Casing	Ductile Iron/PFA
101	Impeller/Shaft Assembly	316 Stainless Steel/PFA
108	Bearing Carrier	Ductile Iron/PFA
109A	Bearing End Cover (Frame-Mounted)	Steel
112	Ball Bearing (Frame-Mounted)	Steel
117A	Stationary Bearing, Outboard	Alpha Sintered Silicon Carbide with Dryguard™
117B	Stationary Bearing, Inboard	Alpha Sintered Silicon Carbide with Dryguard™
117C	Radial Bearing, Outboard	Alpha Sintered Silicon Carbide with Dryguard™
117D	Radial Bearing, Inboard	Alpha Sintered Silicon Carbide with Dryguard™
122A	Stub Shaft (Close-Coupled) <i>not illustrated</i>	Steel
122B	Drive Shaft (Frame-Mounted)	Steel
141C	Clamp Ring	Ductile Iron
157A	Bearing Spacer	PTFE
222L	Set Screw (Close-Coupled) <i>not illustrated</i>	Steel
228	Frame (Frame-Mounted), Motor Adapter (Close-Coupled)	Ductile Iron
332	Lip Seal, Outboard (Frame-Mounted)	Steel/Nitrile
333	Lip Seal, Inboard (Frame-Mounted)	Steel/Nitrile
351	Casing Gasket	PTFE
355A	Socket Head Cap Screw—Drive magnet assy to shaft	Steel
356A	Hex Cap Screw—Clamp Ring to Casing	304 Stainless Steel
356B	Hex Cap Screw—Clamp Ring to Bearing Carrier <i>not illustrated</i>	304 Stainless Steel
360A	Gasket—Bearing End Cover to Frame (Frame-Mounted)	Kraft Paper
360W	Gasket—Frame or Motor Adapter to Clamp Ring	Nitrile Buna Rubber Bound Aramid Fiber
370B	Hex Cap Screw—Frame or Motor Adapter to Clamp Ring	Steel
370C	Hex Cap Screw—End Cover to Frame (Frame-Mounted) <i>not illustrated</i>	Steel
412M	Support Ring	PTFE
496H	Inner Shaft O-Ring	Kalrez® or Equal
740A	Driven Carrier Assembly	Steel/Samarium Cobalt/PFA
740B	Drive Carrier Assembly	Std.—Ductile Iron/Neodymium Iron Boron, Opt.—Ductile Iron/Samarium Cobalt
750A	Containment Shell, Inner	PTFE
750B	Containment Shell, Outer	CFRP

# Dimensions Model 3299

All dimensions in inches and (mm). Not to be used for construction.

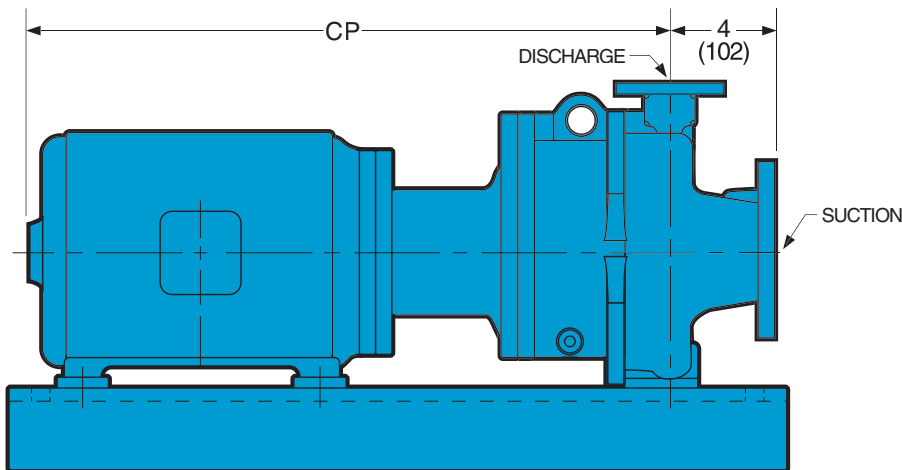
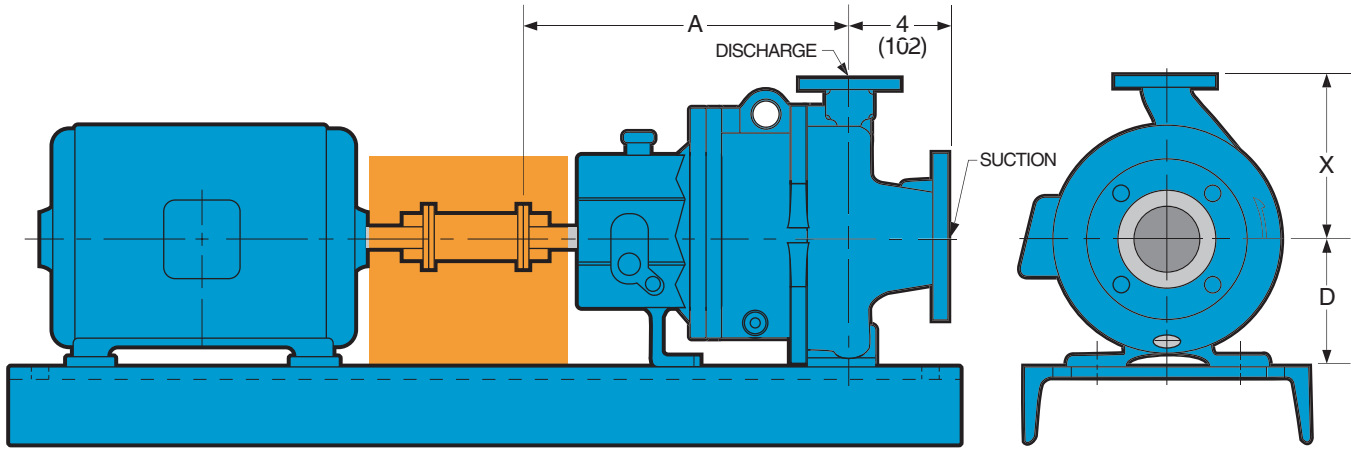

BARE PUMP DIMENSIONS					Weight, lbs (kg)	
Group	Size	A	D	X	Close-Coupled	Frame-Mounted
S	1x1.5-6	13.5 (343)	5.25 (133)	6.5 (165)	161 (73)	171 (78)
	2x3-6				173 (79)	183 (83)
	1x1.5-8				175 (80)	180 (82)
M	1.5x3-8	19.5 (495)	8.25 (210)	8.5 (216)	225 (103)	243 (110)
	1x2-10				245 (111)	263 (120)

CLOSE-COUPLED		
Motor Frame	Group	CP (Approx.)
143TC	S	24.96 (634)
	M	28.73 (730)
145TC	S	25.96 (659)
	M	29.73 (755)
182TC	S	28.09 (713)
	M	30.23 (768)
184TC	S	29.09 (739)
	M	31.23 (793)
213TC	S	30.89 (785)
	M	33.03 (839)
215TC	S	32.39 (823)
	M	34.53 (877)
254TC	S	35.06 (891)
	M	37.2 (945)
256TC	S	36.76 (934)
	M	38.9 (988)
284TSC	S	40.95 (1040)
	M	43.09 (1094)
286TSC	S	N/A (N/A)
	M	43.09 (1094)
324TSC	S	N/A (N/A)
	M	44.91 (1141)
326TSC	S	N/A (N/A)
	M	44.91 (1141)