



Goulds Pumps

Goulds 3410

Small Capacity Double Suction Pumps



Engineered for life

avroa-arm.ru
+7 (495) 956-62-18

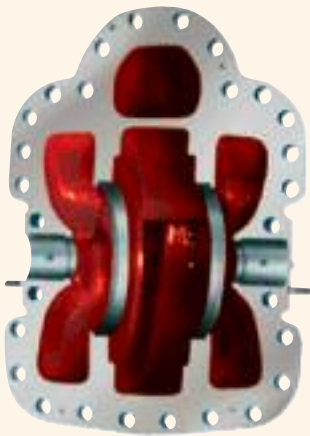

Goulds 3410

Double Suction Pumps Designed for a Wide Range of Industrial, Municipal, and Marine Services.

- ◆ Capacities to 8,000 GPM (1817 m³/h)
- ◆ Heads to 570 feet (174 m)
- ◆ Temperatures to 350° F (177° C)
- ◆ Pressures to 250 PSIG (1724 kPa)

Design Features

- ◆ **Double Suction/Dual Volute Design** assures axial and radial balance for long life, low maintenance.
- ◆ **Horizontally Split Casing** Suction and discharge nozzles in lower half casing for ease of inspection/maintenance.
- ◆ **Wear Rings** Easily replaceable wear rings protect against impeller, casing wear.
- ◆ **Sealing Flexibility** Choice of packing or wide range of mechanical seals.
- ◆ **Maximum Parts Interchangeability** Entire line uses just four rotating assemblies (exclusive of impellers and wear rings).

Services

- ◆ **Process** Quench water, stripper bottoms, reboiler circulation, cooling tower
- ◆ **Pulp & Paper** Primary and secondary cleaner, filtrate, mill water supply shower, fan pump
- ◆ **Primary Metals** Cooling water, quench and leaching
- ◆ **Municipal** High lift, low lift, wash water, waste water, raw water
- ◆ **Utilities** Cooling tower, component cooling, service water
- ◆ **Marine** Bilge and ballast, cargo, cooling water, fire pump

Other Features/Application Flexibility

Optional Oil Lubrication Field convertible with no remachining required.

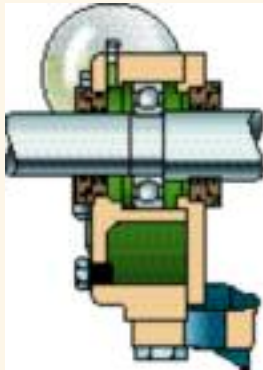

Oil Lubricated
Coupling End Bearings



Oil Lubricated
Thrust End Bearings

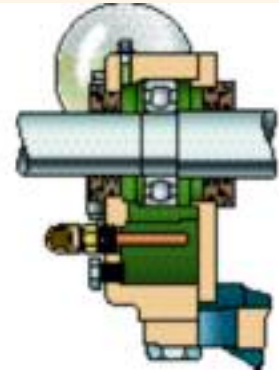

Water Cooled
Bearings

Bearing Protection

**Inpro VBX Labyrinth Seals
Supplied As Standard**

VBX seals are ideal for eliminating contaminants and providing long life with no shaft wear or heat generation.

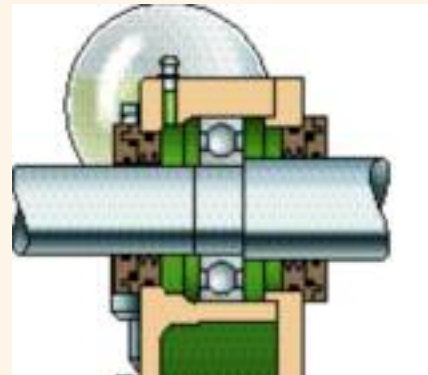

Inpro VBX Labyrinth Oil Seals

Optional Mechanical Seals

A wide variety of mechanical seals (including cartridge and split type) are readily available for maximum sealing flexibility.

Factory installed mechanical seals feature enlarged stuffing box bores for improved seal lubrication and cooling; extended seal life.

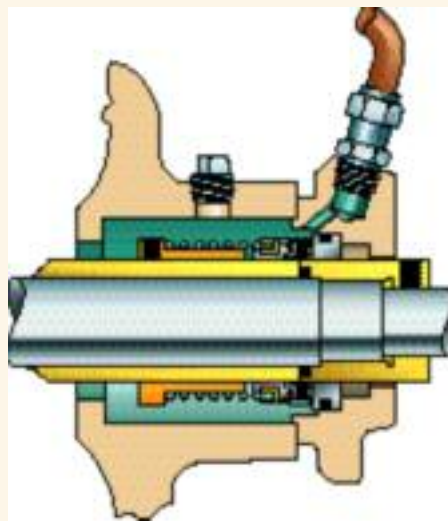

Single Unbalanced Seal

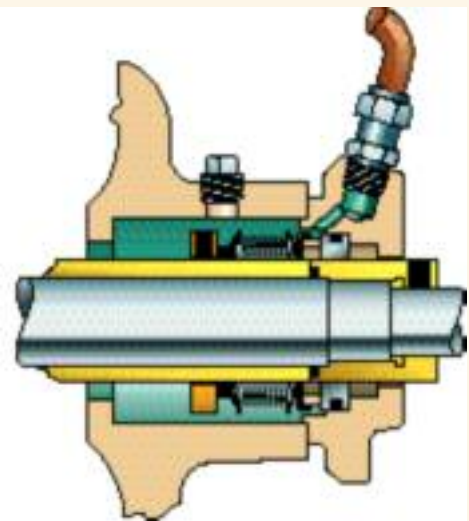

Single Balanced Seal

Hydraulic Coverage 60Hz

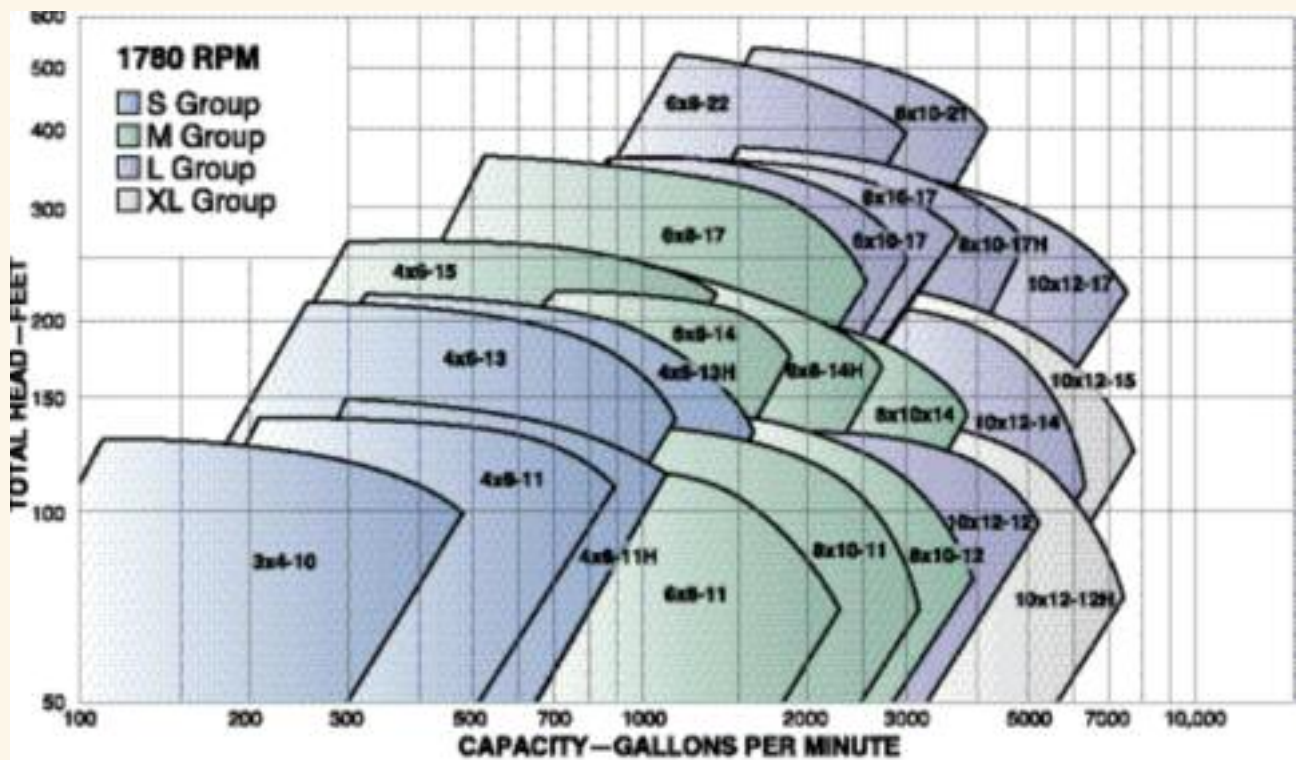
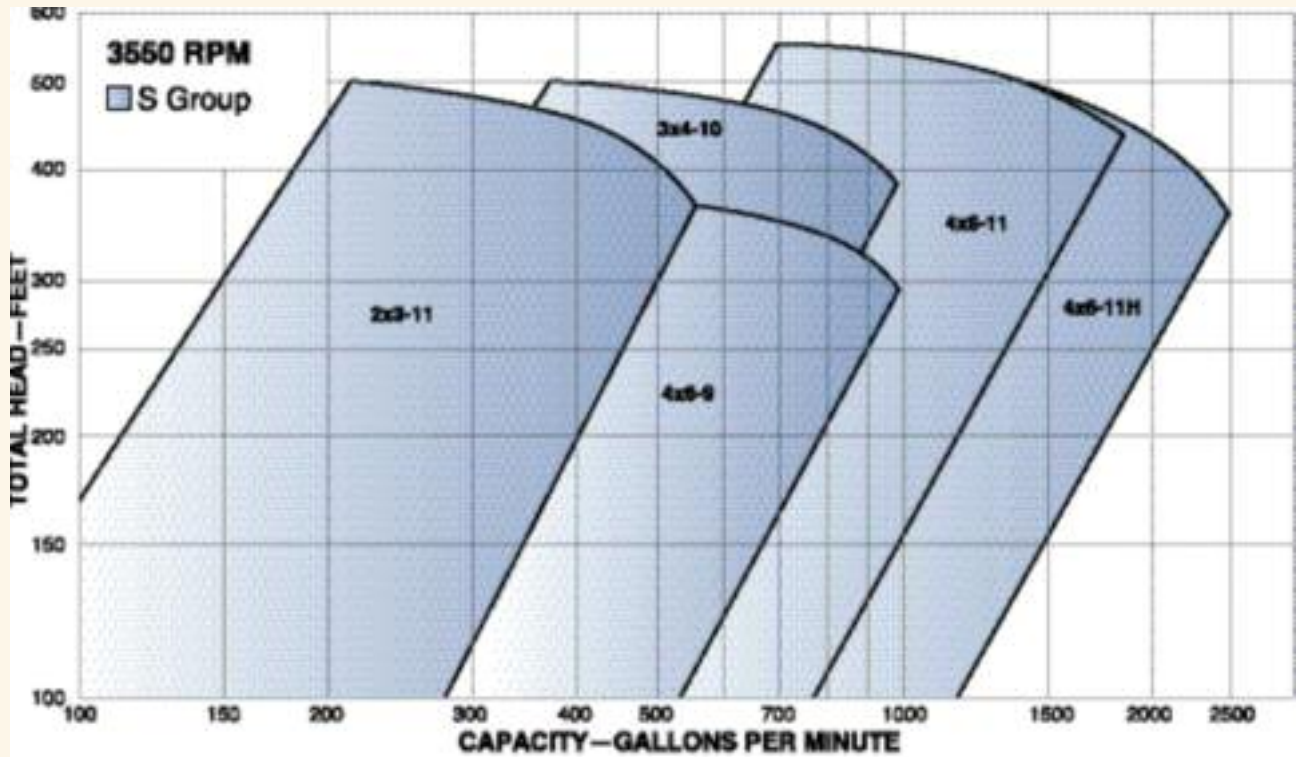

Hydraulic Coverage 50Hz

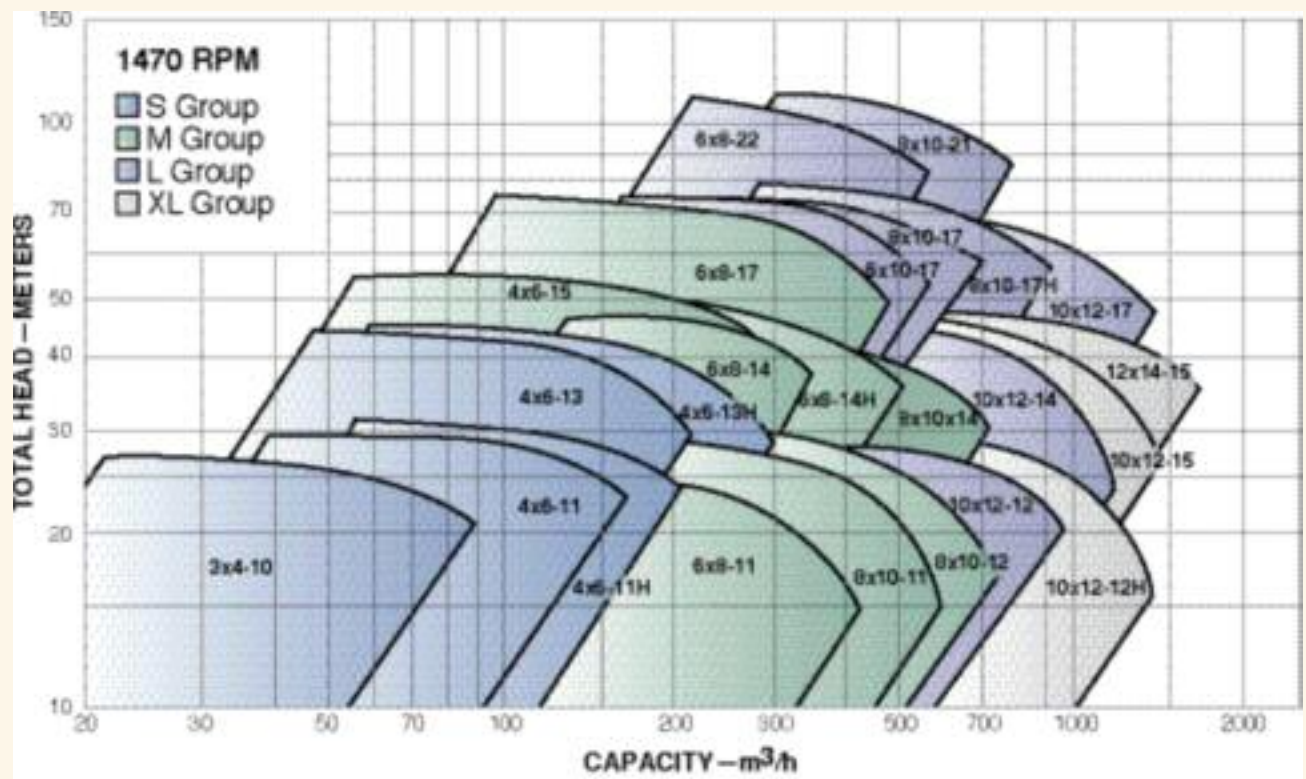
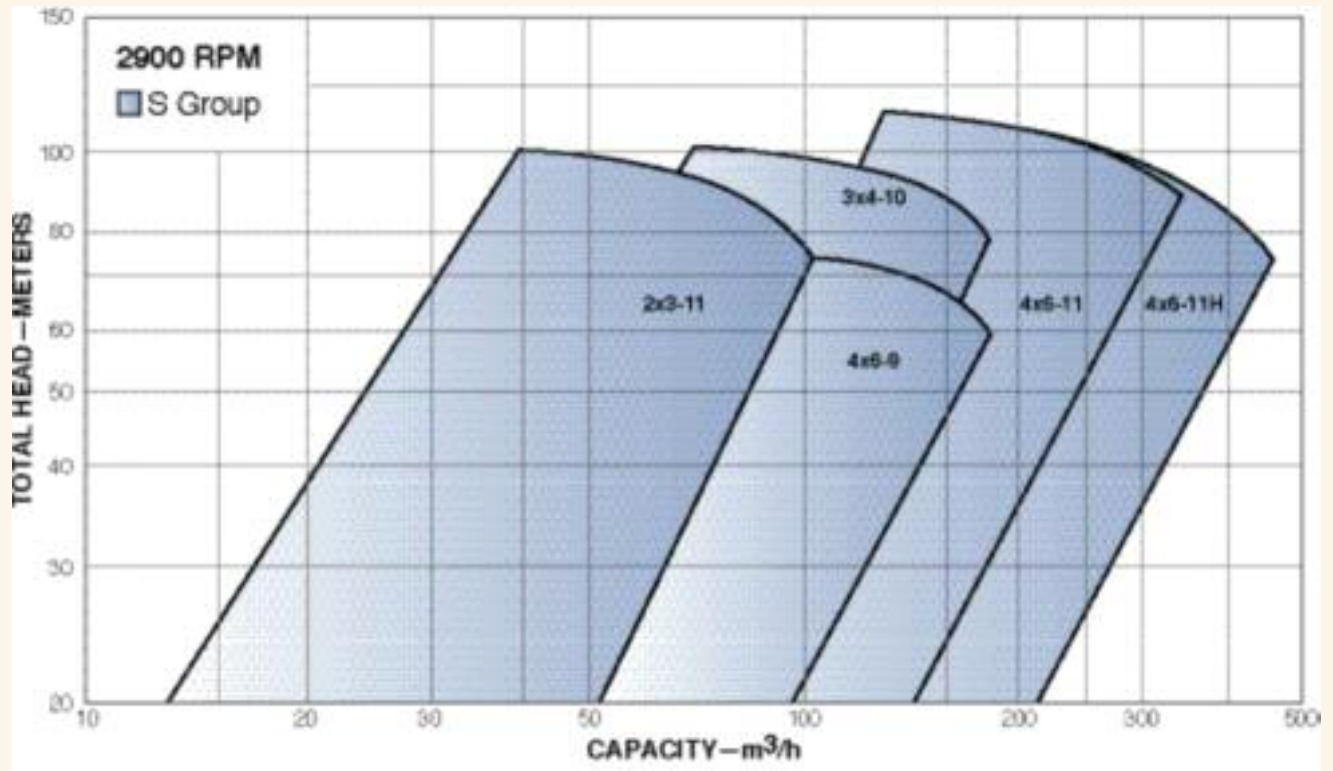

Parts List and Materials of Construction

Item No.	No Req'd Per Pump	Part Name	Material		
			Bronze Fitted	316 SS Fitted	All 316 SS
100	1 Upper 1 Lower	Casing	1003	1003	1203
101	1	Impeller	1179	1203	1203
102	2	Seal Flush Tubing (Optional, Not Illustrated)	Brass	Steel	316 SS
103	2	Wear Ring, Casing	1618	1071	
105	2	Lantern Ring	Glass-Filled Teflon		
106	1 set	Stuffing Box Packing	Square Non-Asbestos		
107	2	Stuffing Box Gland	1203		
109	2	Bearing End Cover	1000		
109A	1	Bearing End Cover, Thrust	Steel		
112	1	Ball Bearing, Outboard	Steel		
113	2	Grease Fitting	Steel		
113A	2	Breather (Optional Oil Lubrication Only)	Steel		
122	1	Shaft	2238*		
124	2	Sleeve Nut (M, L, and XL Groups Only)	1618	2445	
125	2	Stuffing Box Bushing	316		
126	2	Shaft Sleeve (Optional on S Group)	1618	1203	
134	2	Bearing Housing	1000		
142	2	Wear Ring, Impeller (Not Illustrated)	1179	1203	
168	1	Ball Bearing, Inboard	Steel		
178	1	Impeller Key	AISI 1018**		
251	2	Sight Oiler (Optional Oil Lubrication Only)	White Metal and Glass		
320	6	Retaining Set Screw, Impeller Wear Ring (Not Illustrated)	303 SS		
332	1	Labyrinth Seal, Outboard (Inpro VBX)	Bronze/Viton		
333	2	Labyrinth Seal, Inboard (Inpro VBX)	Bronze/Viton		
351	1	Casing Gasket, Parting (Not Illustrated)	1/32" Non-Asbestos		
353	4	Gland Studs	316 SS		
355	4	Hex Nuts	304 SS		
360	2	Gasket, End Cover to Bearing Housing	Kraft Paper		
361	1	Retaining Ring, Thrust Bearing	Steel		
361 H	2	Retaining Ring, Impeller (S Group Only)	Steel	Stainless Steel	
371 C	8	Hex Cap Screw	Steel		
372 U	4	Hex Cap Screw	Steel		
428	2	Gasket, Sleeve to Impeller (M, L, and XL Groups Only)	1/32" Non-Asbestos		
443T	1	Bearing Spacer (L & XL Groups Only)	Steel		
445A	2	Anti-Rotation Pin, Case Wear Ring	AISI 420	AISI 316	
497	2	O-ring, Sleeve Nut	Buna Rubber		

*S Group AISI 420 (Bronze Fitted Constructions), AISI 316 (316 SS Fitted & All 316 SS Constructions) **S Group AISI 303

Materials of Construction

Code	Specification
1000	Cast Iron—ASTM A48 Class 25B
1003	Cast Iron—ASTM A48 Class 30B
1071	Nitronic 60—ASTM A743 Grade CF10SMnN
1179	Bronze—ASTM B584 Alloy C87600
1203	Stainless Steel—ASTM A743 Grade CF8M
1618	Bronze—ASTM B584 Alloy
2238	ASTM A434 Gr. 4140 Class BC
2445	Nitronic 60 Condition A
AISI 304	Stainless Steel—ASTM A276 Type 304
AISI 1018	Steel—ASTM A108 Grade 1018—B1112
AISI 420	Stainless Steel—ASTM A276 Type 420

Sectional View 3410

S Group

Model 3410 S Group is standard shaft sleeves. Sleeves to protect stuffing box area are optional. Impeller is key driven and held axially by retaining rings.

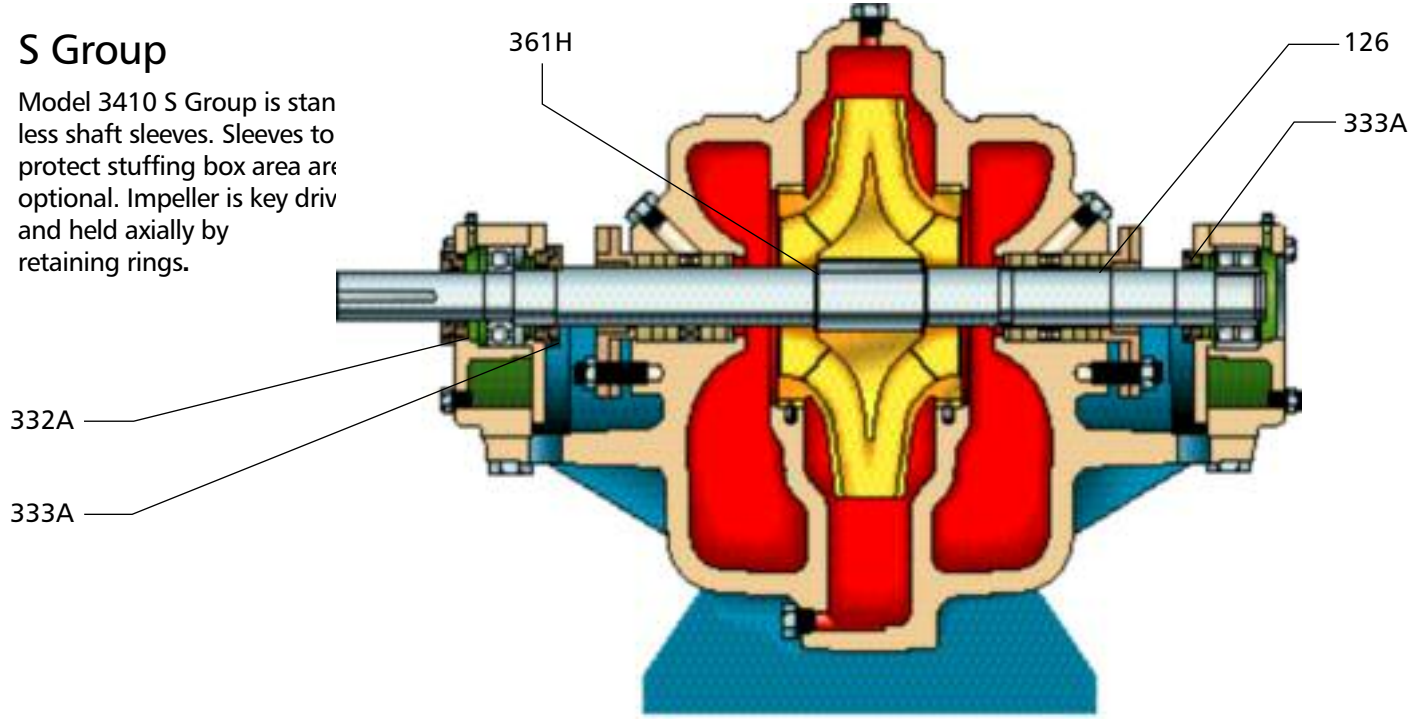

M, L, XL Group

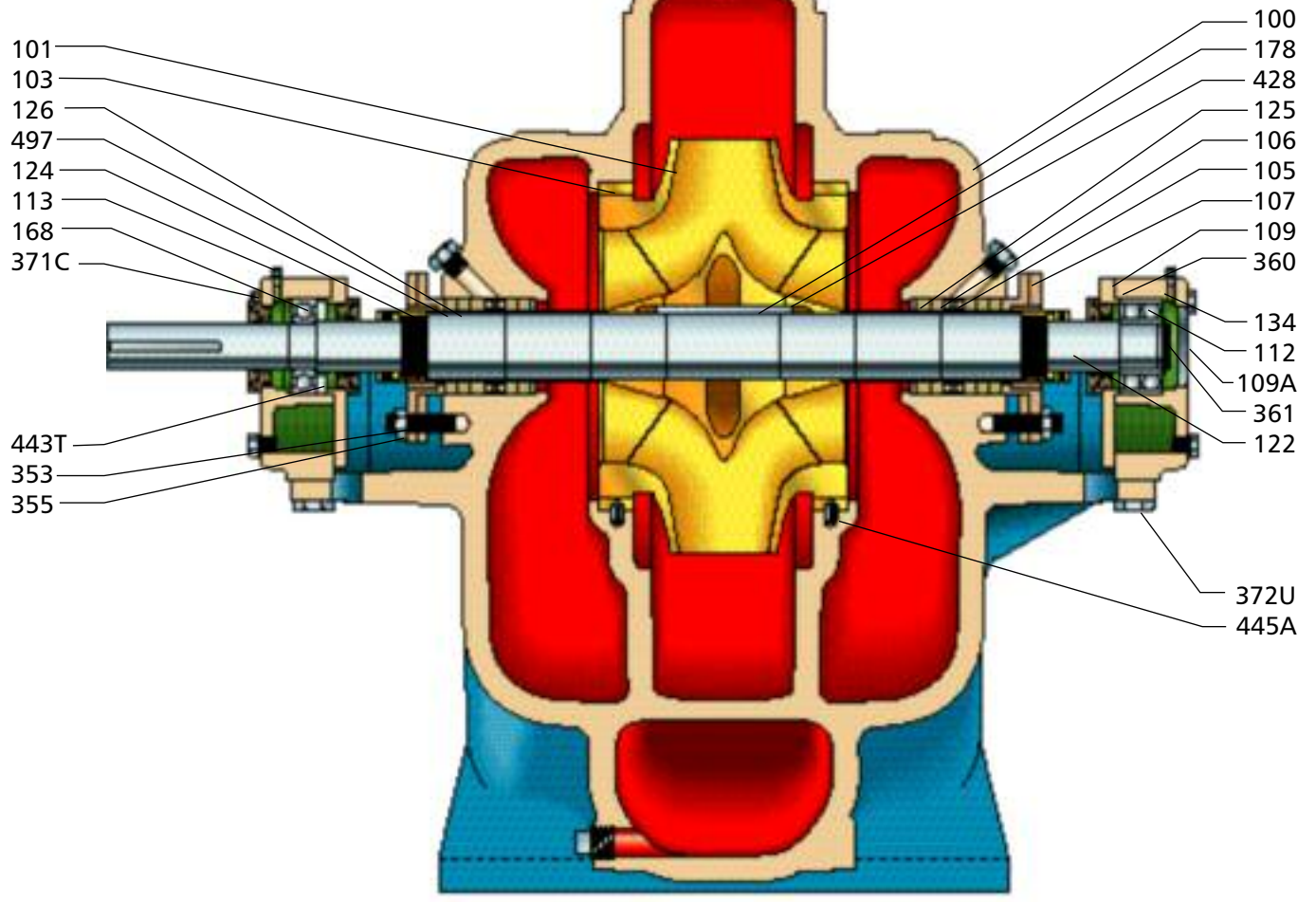



3410 Single Stage, Double Suction Pumps

Standard Design
Industrial, Marine

RENEWABLE CASE WEARING RINGS

Permits easy maintenance of proper running clearances. Locked in place by anti-rotation pins.

DOUBLE SUCTION IMPELLER

Minimizes axial thrust. Polished waterways and fully machined exterior surfaces assure highly efficient, smooth performance.

HEAVY DUTY SHAFT

Designed for minimum deflection in toughest services. Renewable shaft sleeves protect shaft from pumpage.

STUFFING BOX GLANDS

Two-piece investment cast stainless steel glands standard on all constructions.



BALANCED DESIGN

Dual volute casing design equalizes radial forces and lessens radial reaction of shaft and bearings — assures smooth, vibration-free performance. Ideal when pumps must periodically operate at capacities above or below design capacity or during intermittent high head conditions. Combined with double suction impeller for axial balance, the 3410 is designed for long life, low maintenance. (Dual volute casing not available on all sizes.)

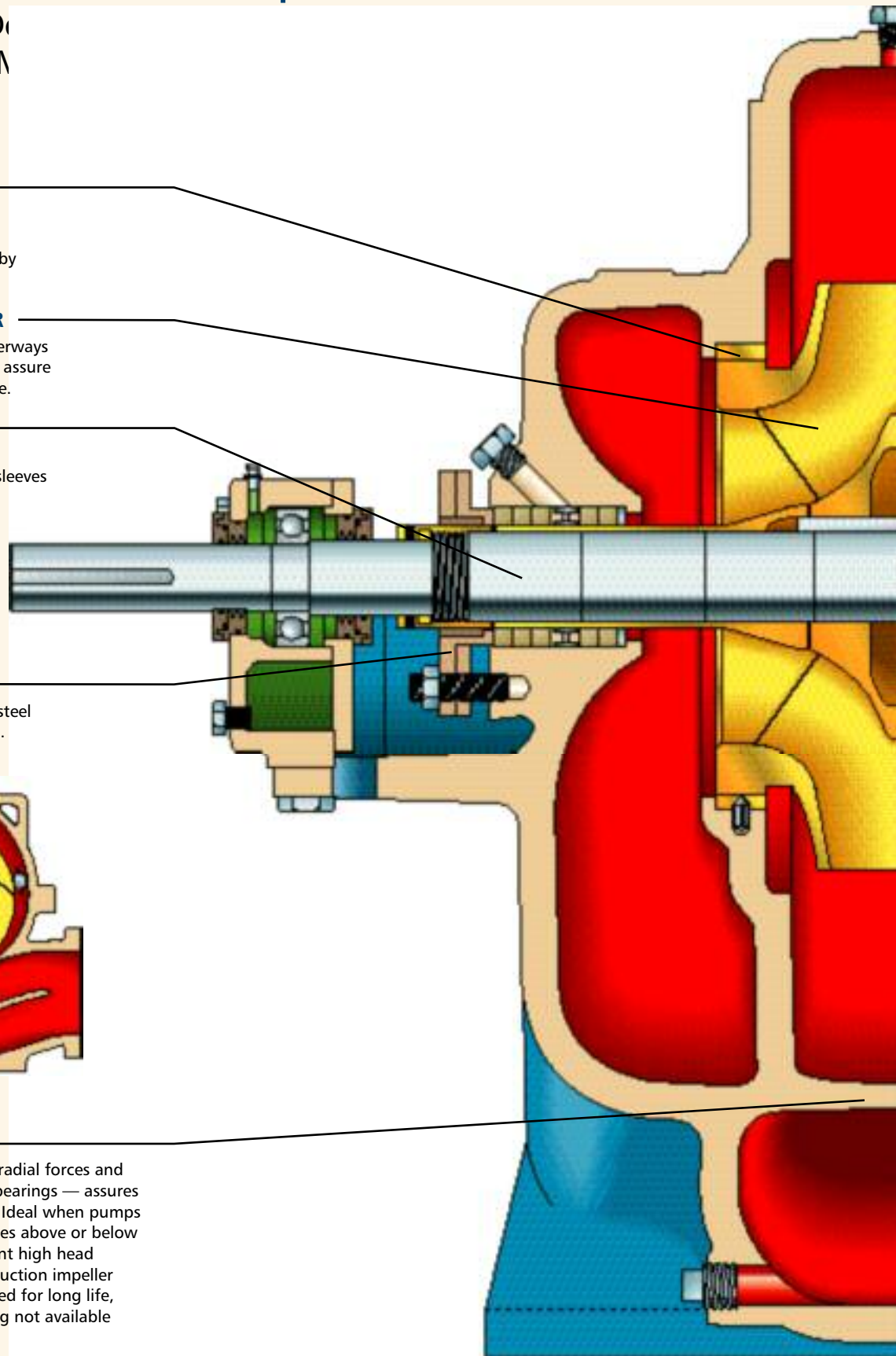

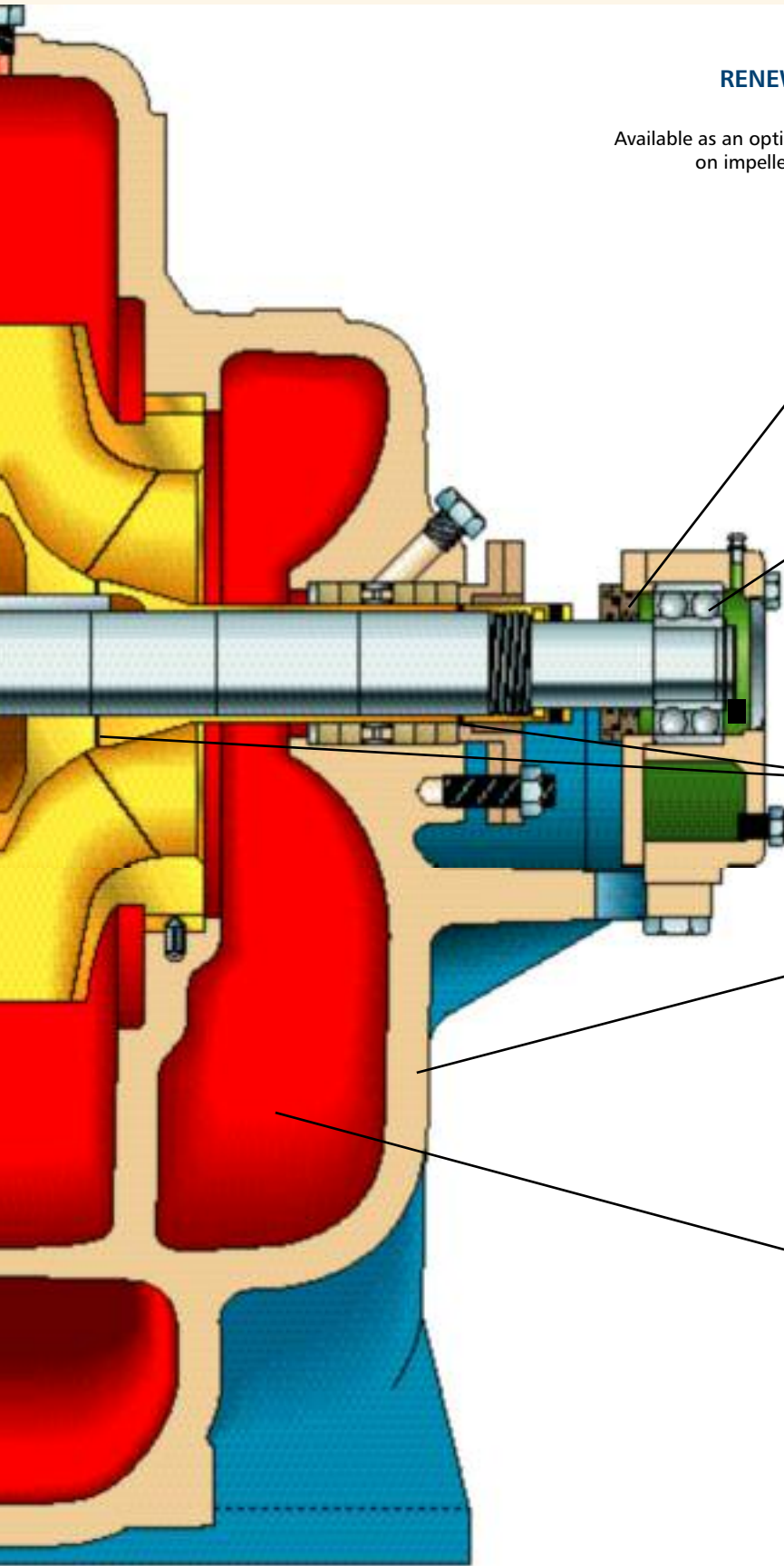

RENEWABLE IMPELLER WEARING RINGS

Available as an option on all sizes. Locked on impeller hub with set screws.

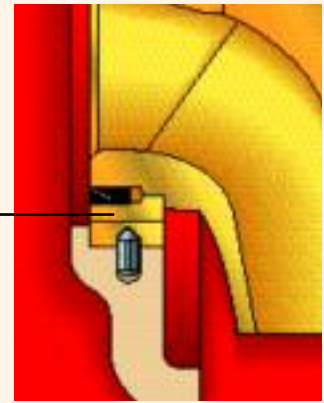

LABYRINTH BEARING PROTECTION

Inpro VBX labyrinth isolators are standard on the Model 3410. Ideal for eliminating contaminants and improving mean time between failure.

DOUBLE ROW THRUST BEARING

Regreasable double row thrust bearing for high axial thrust capability. Locked on shaft in bearing housing positively positions rotating element and carries any residual axial thrust. Oil lubrication with constant level oilers optional.

POSITIVE LIQUID SEALING

Shaft positively sealed from pumpage with gaskets and O-rings.

HEAVY DUTY CASING

Rugged foot-mounted design to resist external forces and vibration. Casing wall designed to withstand high working pressures with minimum distortion. Both suction and discharge connections in lower half, allowing removal of upper half casing for inspection or removal of complete rotating element without disturbing piping or driver.

LARGE INLET AREAS

Reduce NPSH requirement and assure smooth flow to impeller eye for efficient, quiet operation.

Maximum Interchangeability

Entire 3410 Product Line Utilizes Just Four Shafts And Two Bearing Assemblies

S Group

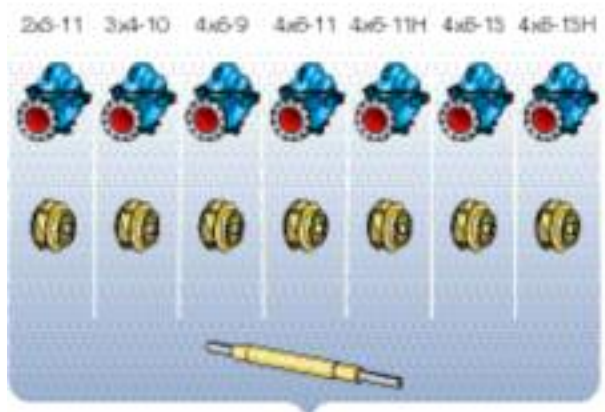

M Group

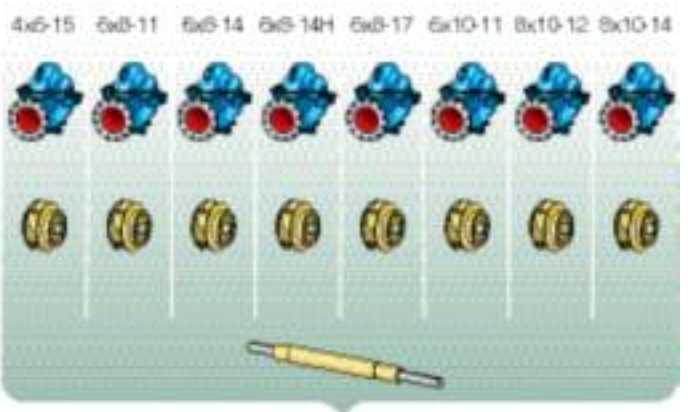

L Group

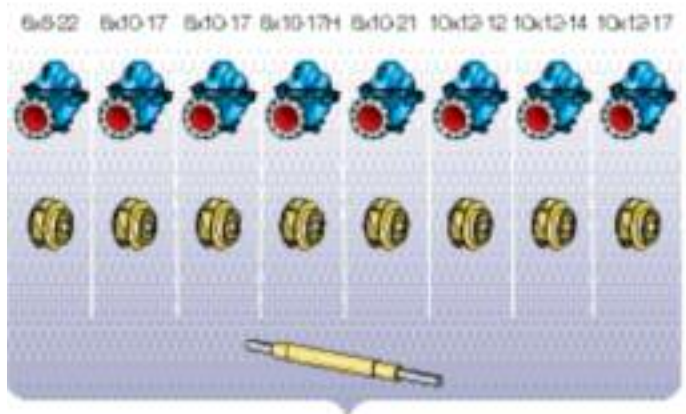

XL Group

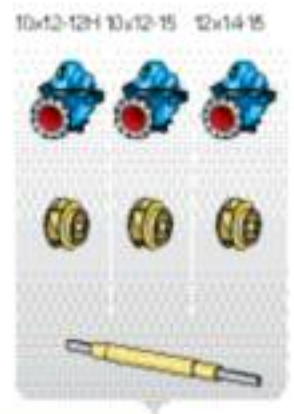

Construction Details All dimensions in inches and (mm), weights in Lbs. and (kg).

		GROUP S						GROUP M						GROUP L						GROUP XL								
		2x3-11	3x4-10	4x6-9	4x6-11**	4x6-11H**	4x6-13	4x6-18H	4x6-15	6x8-11	6x8-14	6x8-14H	6x8-17	8x10-11	8x10-12	8x10-14	6x8-22	6x10-17	8x10-17**	8x10-17H**	8x10-21**	10x12-12**	10x12-14**	10x12-17**	10x12-12H**	10x12-15**	12x14-15**	
PUMP	Weight, Bronze Fitted Bare Pump	330 (150)	333 (151)	334 (152)	410 (186)	410 (186)	450 (205)	472 (215)	637 (290)	692 (315)	665 (302)	665 (302)	885 (402)	737 (335)	856 (389)	996 (453)	1495 (680)	1015 (461)	1286 (585)	1306 (594)	1520 (691)	1229 (559)	1410 (641)	1709 (777)	2168 (985)	1720 (782)	2500 (1136)	
	Weight, Upper Hall Casing	63 (29)	66 (30)	59 (27)	84 (38)	84 (38)	88 (40)	88 (40)	143 (65)	150 (68)	139 (63)	139 (63)	200 (91)	151 (69)	189 (86)	235 (107)	320 (145)	210 (95)	254 (115)	254 (115)	371 (169)	286 (130)	305 (139)	388 (175)	493 (224)	369 (168)	605 (275)	
	Weight, BF Rot. Element	70 (32)	63 (29)	62 (28)	75 (34)	75 (34)	80 (36)	104 (47)	132 (60)	104 (47)	120 (55)	120 (55)	180 (73)	113 (51)	111 (50)	135 (61)	250 (112)	228 (104)	244 (111)	264 (120)	270 (123)	178 (81)	210 (95)	250 (114)	218 (99)	250 (114)	282 (128)	
	Minimum Wall Thickness	3/8 (10)	3/8 (10)	3/8 (10)	3/8 (10)	3/8 (10)	3/8 (10)	7/16 (11)	1/2 (13)	1/2 (13)	1/2 (13)	1/2 (13)	1/2 (13)	1/2 (13)	1/2 (13)	1/2 (13)	5/8 (16)	9/16 (14)	1/2 (13)	1/2 (13)	1/2 (13)	9/16 (14)	1/2 (13)	5/8 (16)	5/8 (16)	5/8 (16)	5/8 (16)	5/8 (16)
	Max. Dia. Spherical Solids	5/16 (8)	5/16 (8)	1/2 (13)	5/8 (16)	5/8 (16)	3/8 (10)	3/8 (10)	7/16 (11)	13/16 (21)	15/16 (21)	1-1/16 (27)	9/16 (14)	3/4 (19)	1-1/8 (29)	1-1/16 (27)	5/8 (16)	5/8 (16)	1-1/16 (27)	1-1/16 (27)	1-1/16 (27)	1-3/16 (30)	15/16 (24)	1-1/4 (32)	1-1/4 (32)	1-3/8 (35)	1-1/2 (38)	
	Casing Cap Gal. (L)	1.7 (6.4)	3.8 (3.2)	3.2 (12.1)	5.8 (22.0)	5.8 (22.0)	8.2 (23.5)	6.2 (23.5)	9.9 (37.5)	10.0 (37.9)	12.0 (45.4)	12.0 (45.4)	17.3 (65.5)	14.0 (53.0)	22.0 (83.3)	20.6 (78.0)	20.5 (77.6)	18.0 (68.1)	23.4 (88.6)	23.4 (88.6)	32.5 (123)	33.0 (128)	20.8 (78.7)	40.2 (152)	48.5 (176)	43.0 (163)	65.7 (249)	
STUFFING BOX	Stuffing Box Bore	2-1/2 (64)†						2-7/8 (73)†						3-3/4 (95)†						4 (102)†								
	Stuffing Box Depth to Bushing	2-5/8 (67)						2-5/8 (67)						3-5/8 (92)						3-5/8 (92)								
	Packing Size	3/8 x 3/8 (10 x 10)						3/8 x 3/8 (10 x 10)						1/2 x 1/2 (13 x 13)						1/2 x 1/2 (13 x 13)								
	No. of Packing Rings	5						5						5						5								
	Width of Lantern Ring	5/8 (16)						5/8 (18)						7/8 (22)						1 (25)								
SHAFT AND BEARINGS	Dia. of Shaft in Impeller	1-13/16 (46)						1-15/16 (49)						2-9/16 (65)						2-13/16 (71)								
	Dia. of Shaft in Sleeve	(w/ Optional Sleeve)* 1-1/2 (33)						1-7/8 (48)						2-1/2 (65)						2-3/4 (70)								
	Dia. of Shaft in Coupling	1-3/8 (35)						1-3/8 (35)						2-1/8 (54)						2-1/8 (54)								
	O.D. of Shaft Sleeve	(w/ Optional Sleeve) 1-3/4 (45)						2-1/8 (54)						2-3/4 (70)						3 (76)								
	Bearing Span	20-1/8 (511)						24-1/2 (622)						28-7/8 (708)						31-9/18 (802)								
	Bearing Coupling End	6207						6207						6211						6211								
	Bearing Thrust End	5306						5306						5309						5309								
	Max. BHP per 100 RPM	9.72 (7.25 kW)						9.72 (7.25 kW)						35.87 (26.76 kW)						35.87 (26.76 kW)								
GENERAL	Max. Allow. Suct. Press.	75 PSIG (527 kPa)																										
	Parting Gasket Thickness	1/32 (8)																										
	Max. Liquid Temp. w/o cooling	250°F (121°C)																										
	Max. Liquid Temp. w/cooling	350°F (177°C)																										

NOTES:
 † Dimensions shown are for packed box only.
 * O.D. of shaft through stuffing box is 1-3/4 in. in standard S Group sleeveless construction.
 ** Dual Volute Casings

Vertical Versatility

Goolds Model 3410 is available in a vertical configuration (3410 V). This arrangement is ideal for applications with limited space such as shipboard service. A rugged fabricated steel frame supports the pump and driver, providing a machined fit for positive alignment when using standard P-base or C-Face motors.

Model 3410 V

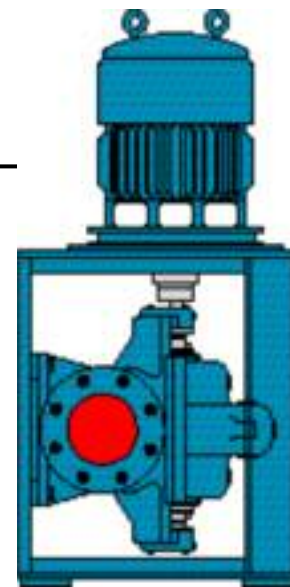

Dimensions

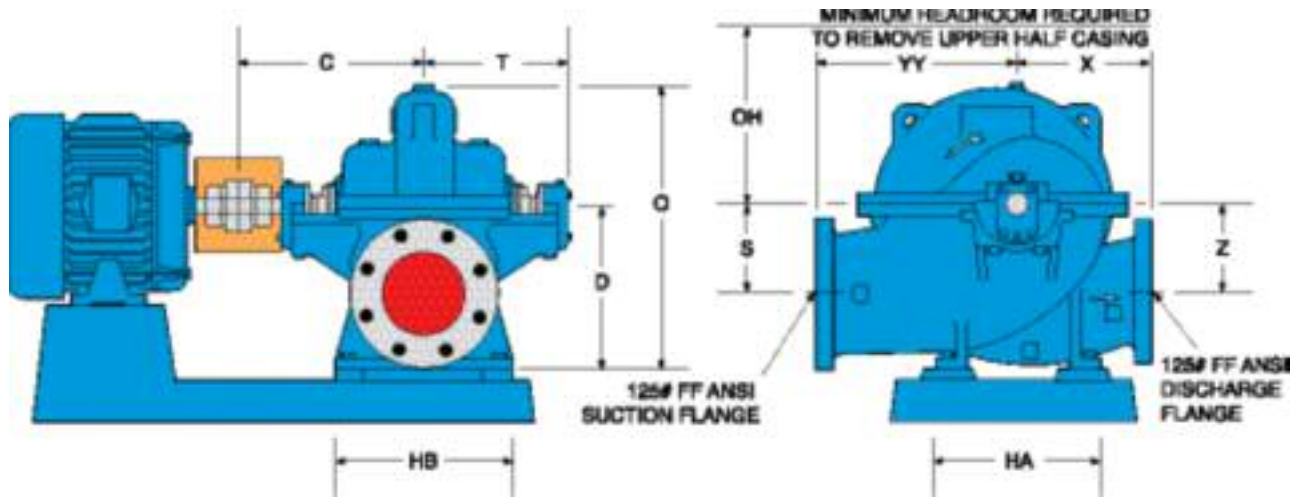

DIMENSIONS DETERMINED BY PUMP												
Frame Group	Pump Size	C	T	D	O	OH	S & Z	X	YY	HA	HB	Wt. Lbs (kg)
S	2x3-11	14.62 (371)	11.76 (209)	11.50 (292)	18.38 (467)	12.38 (314)	7.25 (184)	7.50 (190)	9.00 (229)	12.00 (305)	12.50 (318)	330 (150)
	3x4-10				18.91 (480)	12.75 (324)	7.00 (178)	9.00 (229)	10.50 (267)			333 (151)
	4x6-9				17.88 (454)	10.88 (276)	6.00 (152)	8.50 (216)	10.00 (254)			334 (152)
	4x6-11/H				19.22 (488)	13.25 (336)	6.00 (152)	10.50 (267)	12.38 (314)			410 (186)
	4x6-13/H				20.59 (523)	15.88 (403)	6.00 (152)	11.00 (279)	13.25 (336)			472 (215)
M	4x6-15	18.00 (457)	13.88 (353)	16.00 (406)	25.88 (657)	17.38 (441)	9.50 (241)	10.00 (254)	14.50 (368)	16.00 (406)	16.75 (425)	637 (290)
	6x8-11				26.44 (672)	16.00 (406)	9.00 (229)	12.00 (305)	14.50 (368)			692 (315)
	6x8-14/H				25.75 (654)	16.75 (425)	9.00 (229)	13.00 (330)	15.50 (394)			665 (302)
	6x8-17				27.88 (708)	20.62 (524)	9.00 (229)	14.25 (362)	15.75 (400)			885 (402)
	8x10-11				25.50 (648)	15.25 (391)	9.00 (229)	13.25 (336)	17.00 (432)			737 (335)
	8x10-12				27.31 (694)	17.38 (441)	8.75 (222)	13.00 (330)	19.50 (495)			858 (398)
	8x10-14				28.50 (724)	19.50 (495)	8.75 (222)	13.88 (352)	19.50 (495)			996 (453)
L	6x8-22	21.00 (533)	16.28 (414)	22.00 (559)	40.50 (1029)	22.50 (572)	13.50 (343)	20.50 (520)	22.00 (559)	22.50 (572)	18.00 (457)	1495 (680)
	6x10-17				33.88 (860)	20.62 (524)	11.00 (279)	16.50 (419)	20.00 (508)			1015 (461)
	8x10-17/H				34.06 (865)	20.88 (530)	10.00 (254)	16.50 (419)	20.00 (559)			1286 (585)
	8x10-21				36.31 (922)	24.88 (632)	13.00 (330)	17.00 (432)	20.30 (521)			1520 (691)
	10x12-12				34.88 (886)	19.12 (486)	11.00 (279)	14.00 (356)	21.00 (533)			1229 (559)
	10x12-14				34.00 (864)	19.25 (489)	11.00 (279)	16.75 (426)	21.00 (533)			1410 (641)
	10x12-17				37.50 (952)	30.75 (781)	11.50 (292)	17.62 (448)	22.50 (572)			1709 (777)
XL	10x12-12 H	23.19 (589)	17.64 (448)	24.00 (610)	39.50 (1003)	21.75 (552)	13.00 (330)	15.00 (381)	22.00 (559)	22.50 (572)	27.00 (686)	2168 (985)
	10x12-15				38.00 (965)	21.50 (533)	13.00 (330)	16.00 (406)	24.00 (610)			1720 (782)
	12x14-15				36.50 (927)	21.75 (552)	13.00 (330)	18.00 (457)	25.00 (635)			2500 (1136)

All dimensions are in inches (mm) and are not to be used for construction or installation purposes.
 Sizes 2x3-11, and 4x6-11/H, 3x4-10, 8x10-21 & 6x8-22 are furnished with 250# FF discharge flange as standard.
 Standard rotation is right hand (CW). Optional rotation is left hand (CCW).
 Steel casings will have 150# or 300# flanges.

Specifications 3410

General

Pump shall be single stage, double suction design. Materials shall be bronze-fitted, 316 stainless steel trim or all 316SS. High efficiency, heavy duty design and maintenance features shall be of primary importance as described in following specifications.

Casing

Shall be horizontally split with upper and lower halves bolted together. Flanged suction and discharge connections shall be located in lower half. Removal of upper half shall permit inspection, maintenance or removal of entire rotating element without disturbing suction or discharge piping or driver. Seats for stuffing box bushing shall be cast and bored integrally with lower half casing. Casing shall be supported by integrally cast feet. Upper half shall have taps for seal piping, priming and vents. Lower half shall have taps for gauges and draining. Casing shall have permanently fixed stainless steel nameplate.

Impeller

Shall be enclosed, double suction to provide hydraulic balance, and cast in one piece. Exterior surfaces shall be machined, interior water ways hand finished. Shall be dynamically balanced and keyed to shaft.

Wearing Rings

Case wear rings shall be supplied to maintain proper running clearance with impeller hubs and to minimize leakage between suction and discharge chambers of casing. Shall be held in position by anti-rotation pins. Impeller shall be designed to accept impeller wear rings. Impeller rings shall be held in position by axial set screws.

Shaft

Shall have as short a span as possible to minimize deflection and vibration. Shall be completely sealed by gaskets between the shaft sleeves and impeller hubs to assure shaft is completely dry during operation.

Shaft Sleeves (Except S Group)

Shall be held in position by sleeve nuts located outside the stuffing box area. Shall be key driven at the impeller end. An O-ring seal shall be provided to prevent leakage between sleeves and sleeve nuts.

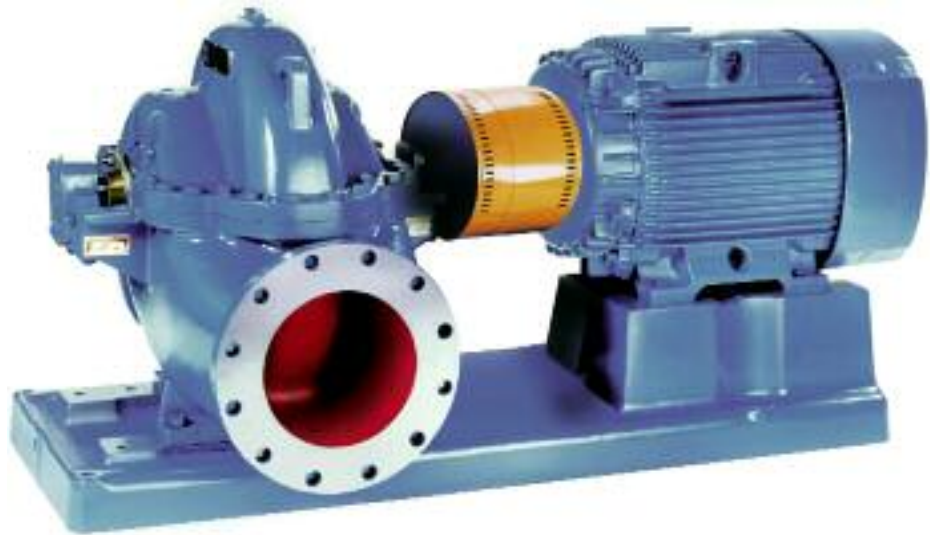

Stuffing Boxes

Shall be integral with casing. Shall contain die-formed packing, split, removable lantern rings and renewable stuffing box throat bushings. Shall have tapped openings for water sealing either from casing or from outside source. Glands shall be split so it will be unnecessary to unbolt gland halves when repacking box.

Mechanical Seals

Pump shall be furnished with (single, double balanced, cartridge) mechanical seals.

Bearing Housings

Seats shall be cast and bored integrally with lower half casing to assure accurate alignment of rotating assembly without need for external adjustment.

Bearings

Double row ball bearing shall be provided on thrust end; single row deep groove ball bearing on coupling end. Thrust bearing shall be held in position on shaft with tapered snap ring and locked in bearing housing. Radial bearing shall be free to float axially in housing to take radial load only. Housings shall be completely sealed by Inpro VBX labyrinth seals to exclude moisture and dirt making units suitable for outdoor installation. Shall be grease lubricated with reliefs to prevent over lubrication.

Bedplate and Coupling

Bedplate shall be cast iron with drip collection chamber, tapped drain connection and opening for grouting. Flexible coupling shall be supplied.

The Most Complete Line of Double Suction Pumps In The Industry

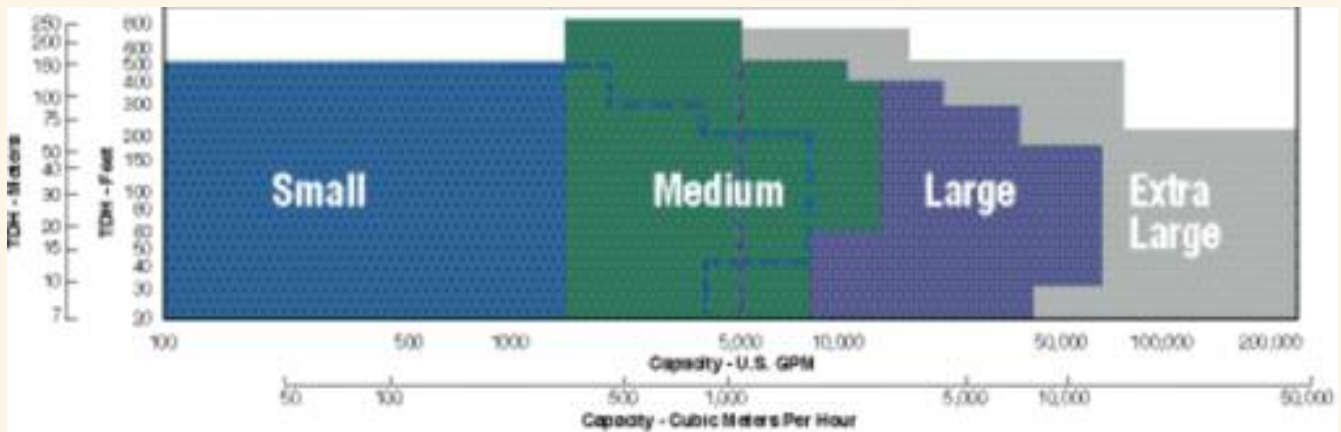

Small Capacity

Flows to 8,000 GPM



3408

Capacities to 6,000 GPM (1363 m³/h)
Heads to 570 Ft. TDH (174 m)
Temperatures to 250° F (120° C)
Working Press. to 400 PSI (2758 kPa)

3410

Capacities to 8,000 GPM (1817 m³/h)
Heads to 570 Ft. TDH (174 m)
Temperatures to 350° F (177° C)
Working Press. to 250 PSI (1724 kPa)



Medium Capacity

Flows to 12,000 GPM

3409

Capacities to 12,000 GPM (2725 m³/h)
Heads to 850 Ft. TDH (259 m)
Temperatures to 250° F (120° C)
Working Press. to 400 PSI (2758 kPa)



Large Capacity

Flows to 65,000 GPM



3420

Capacities to 65,000 GPM (14,762 m³/h)
Heads to 400 Ft. TDH (122 m)
Temperatures to 275° F (135° C)
Working Press. to 200 PSI (1379 kPa)

Extra Large Capacity

Flows to 225,000 GPM

3498

Capacities to 225,000 GPM (51,098 m³/h)
Heads to 800 Ft. TDH (244 m)
Temperatures to 275° F (135° C)
Working Press. to 250 PSI (1724 kPa)





PRO Services® Extending Equipment Life...

Product Repair (all types and brands of rotating equipment)

- Service Center Repair
- Field Service
- Parts Supply

Reliability Improvement

- Inventory Management
- Replacement/Exchange
- Turnkey Repair/Installation
- Training

Optimization of Assets

- Predictive Analysis/Condition Monitoring
- Root Cause Failure Analysis
- Pump & System Assessments
- Upgrades – Mechanical & Hydraulic
- Maintenance Management/Contract Maintenance

-
- Technical Expertise
 - Factory Trained Service Personnel
 - Quality
 - Fast Turnaround
 - Emergency Service – 24 hours/day, 7 days/week
 - ISO and Safety Certified

PROSMART

ProSmart® provides continuous machinery monitoring to identify little problems before they become big problems...like downtime.

Using wireless technology, advanced signal processing capabilities, and easy-to-deploy sensors, ProSmart offers an affordable means to monitor all of your rotating equipment anywhere in the world. By identifying and alerting you to changes in operating conditions, ProSmart increases your time to respond to either correcting the upset condition, or properly plan its repair.



Key Features include:

- Continuous data acquisition and analysis – ProSmart collects vibration, temperature, and available process conditions every five seconds; saving you time from routine data collection.
- Automatic Notification and Accessibility – By alerting when a machine goes into distress, you are able to focus your resources on recovery activities. The ProNet web-hosted solution allows access to information anywhere in the world through a standard Internet browser connection.
- Advanced diagnostic tools – More than simple overall data, ProSmart provides advanced analysis capabilities such as time-waveform, spectral, and spectral windowing.
- Easy to deploy – Using plug and play sensors, wireless connectivity, and an industrially hardened enclosure, ProSmart can be easily deployed throughout your plant, including hazardous areas.

PUMPSMART

PumpSmart® is the latest advancement in pump control and protection to reduce energy consumption, increase uptime and decrease maintenance cost. It allows the pump to be right-sized to the application by dialing in the speed and torque which increases flow economy, reduces heat and vibration, and improves overall system reliability.

- **Simplified Pump Control** — PumpSmart was designed specifically to optimize pumping applications and can be used to control a single pump or coordinate between multiple pumps without the need for an external controller.
- **Pump Protection** — PumpSmart guarantees to protect the pump from upset conditions with patented sensorless pump protection algorithms.
- **Smart Flow** — PumpSmart features a sensorless flow function for centrifugal pumps that can calculate the flow of the pump within ± 5% of the pump rated flow.
- **Drive for the DCS** — While most VFDs can only provide basic information, PumpSmart offers unparalleled insight to the pump operation which allows for smoother process control and efficiency.
- **Pump Experts** — PumpSmart is a variable speed drive with pump-specific algorithms imbedded into the drive. With over 150 years of pump knowledge, let the pump experts take responsibility of your pump system.

