

 **GOULDS PUMPS**

# Goulds V-Series

Vertical Turbine Pumps

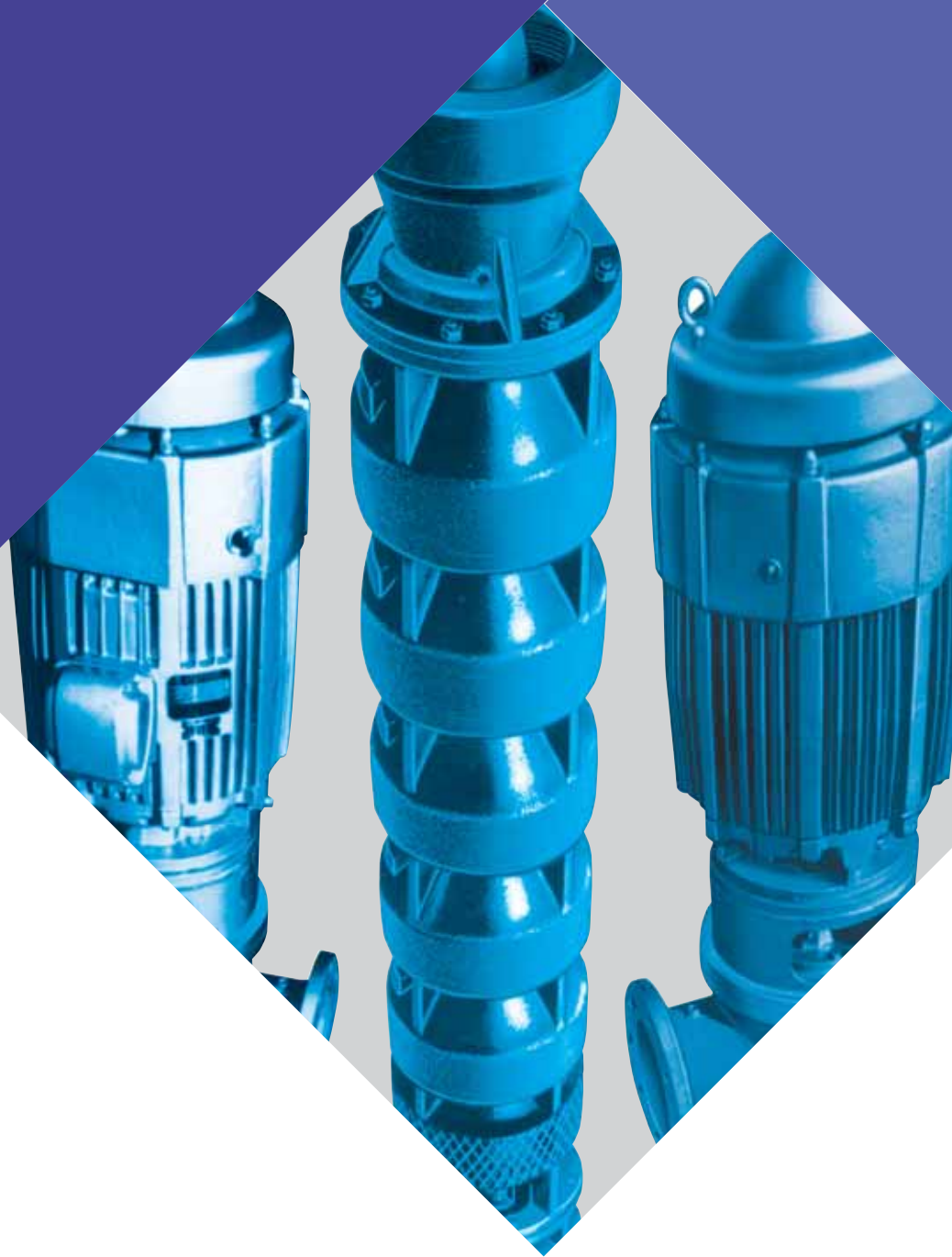

**avrora-arm.ru**  
**+7 (495) 956-62-18**



**ITT**

ENGINEERED FOR LIFE



# Goulds Vertical Turbine Pumps

## Flexibility by Design:

### Three Pump Models, One Common Bowl Assembly

The three different pump models in the vertical turbine line have one thing in common – the hydraulic design of the pump bowl assembly. Using state-of-the-art techniques in turbine pump design, Goulds vertical turbine line covers a wide range of hydraulic conditions to meet virtually every pumping service in the industry with optimum efficiency.

Goulds flexibility of design allows the use of a wide range of materials and design features to meet the custom requirements of the user. No matter what the requirements, whether low first cost, ease of maintenance, optimum efficiency or tough service conditions, Goulds can make the pump to best satisfy the requirements.

This bulletin is designed to assist the user in selecting the best pump for the conditions required; however, any questions will be answered promptly by calling the Goulds sales office or representative in your area.

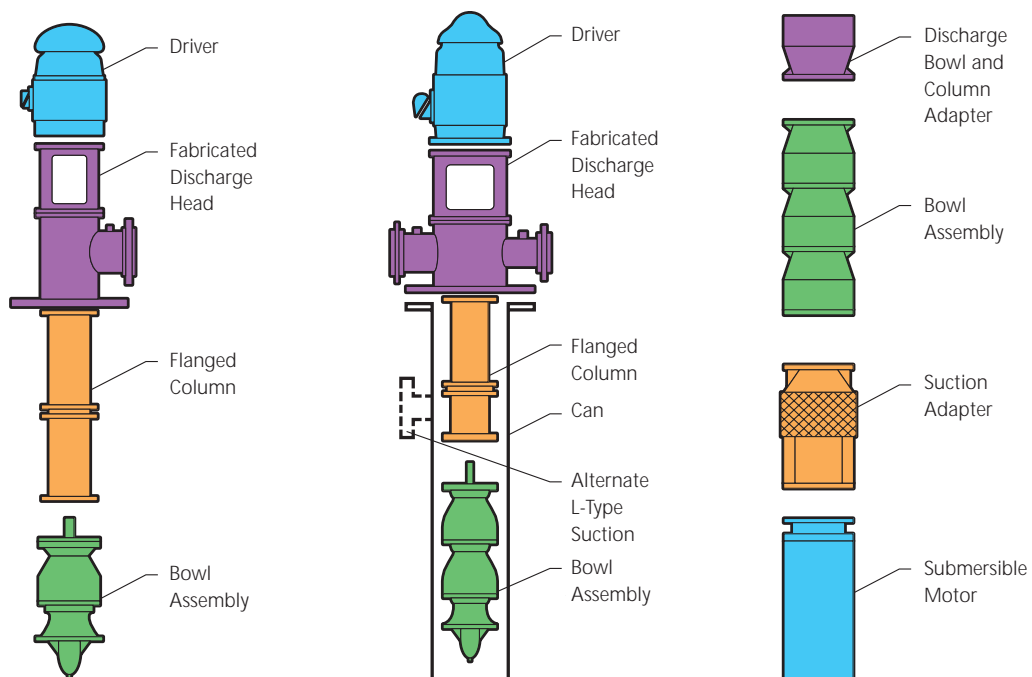

# Goolds Vertical Turbine Pumps



## Pump Bowl Assembly

The bowl assembly is the heart of the vertical turbine pump. The impeller and diffuser type casing are designed to deliver the head and capacity that your system requires in the most efficient way possible. The fact that the vertical turbine pump can be multi-staged allows maximum flexibility both in the initial pump selection and in the event that future system modifications require a change in the pump rating. Submerged impellers allow pump to be started without priming.

A variety of material options allows the selection of a pump best suited for even the most severe services. The many bowl assembly options available assure that the vertical turbine pump satisfies the users' needs for safe, efficient, reliable and maintenance-free operation.

## Standard Design Features

- **Suction Bell** - Allows smooth entry of liquid into impeller eye, minimizes vortex formation.
- **Suction Bell Bearing** - Provided for shaft stability.
- **Sand Collar** - Prevents solids from entering suction bearing.
- **Impeller** - Semi-open or enclosed for appropriate service.
- **Taper Lock** - Alloy steel for fastening impellers on 17" and smaller sizes.
- **Keyed** - Impeller fastened onto the shaft by keyed split ring.
- **Pump Shaft** - Heavy duty 416SS standard, available in 316SS, 17-4 PH, Monel and other alloys for strength and corrosion resistance.
- **Diffuser Bowl** - Available in variety of cast materials. Glass lined cast iron standard through 18" sizes.
- **Stages** - Flanged and bolted together for ease of maintenance.
- **Sleeve Type Bearing** - Provided at each stage to assure stable operation away from critical speed.
- **Flanged Bowls** - Registered fits ensure positive alignment, ease of maintenance.

In addition to standard features and options shown here, other features are available.

- Hydraulic balancing of impellers to reduce axial downthrust and achieve longer thrust bearing life.
- Independent flushing of bowl bearings and wear rings for abrasive services.
- Hard facing of shaft journals and bearings to protect against abrasion and increase interval between maintenance periods.
- Interior coating on bowls for improved efficiency.
- Dynamic balancing of impellers.
- Strainers to prevent foreign objects from entering the pump.





# Pump Bowl Assembly Options

## Choice of Semi-Open or Enclosed Impellers

Available in alloy construction for a wide range of corrosive/abrasive services.

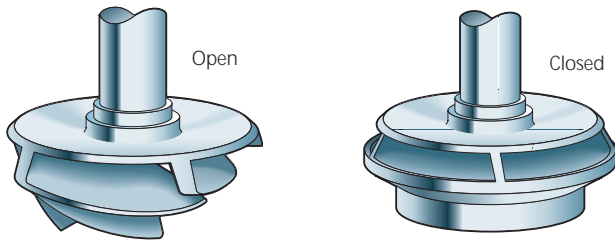

## Strainers

Basket or cone strainers are available to provide protection from large solids.

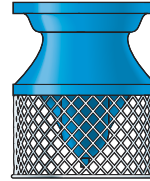

## Low NPSH First Stage X Impellers

For low NPSH applications. Both large eye and mixed flow first stages available; minimizes pump length.

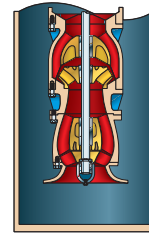

## Keyed Impellers

Keyed Impellers are standard on 18" and larger sizes; furnished on all pumps for temperatures above 180° F (82° C) and on cryogenic services. Regardless of size, keyed impellers provide ease of maintenance and positive locking under fluctuating load and temperature conditions.



## Hardfacing

Hardfacing the surface of bearing and shaft to protect against wear from abrasives in the bearing area.

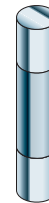

## Dual Wear Rings

Available for enclosed impellers and bowls; permits re-establishing initial running clearances and efficiency at lower cost. Hard facing of wear rings can be flushed when solids are present in pumpage.



## Rifle Drilling Discharge Bowl

Rifle drilling of bowl shafts available for bearing protection on abrasive services. Discharge bowl included with enclosed lineshaft construction.



# Flanged Column



Column sections are provided with flanged ends incorporating registered fits for ease of alignment during assembly. Facilitates disassembly where corrosion is a problem. Our standard bearing retainers are welded into the column section.

## Open Lineshaft Bearing

Flanged column / product lubricated lineshaft is recommended for ease of maintenance or whenever a special bearing material is required.

Keyed lineshaft coupling available in all sizes for ease of maintenance. Various bearing materials available. Renewable shaft sleeve or hard facing of shaft available for longer life.

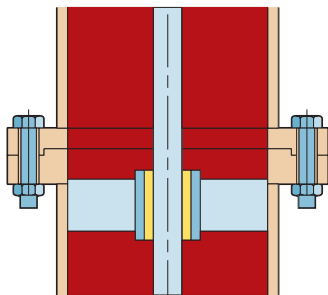

## Enclosed Lineshaft

The lineshaft is protected by water flushing the enclosing tube bearing on corrosive / abrasive services. Oil lubricated lineshaft available on long settings.

Alignment is attained by register fit between the flange faces.

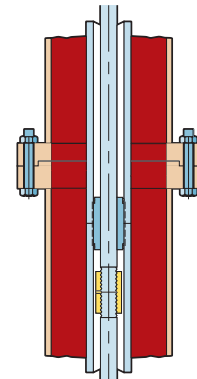

## Threaded Lineshaft Coupling

Threaded lineshaft coupling is commonly used for lower horsepower pumps. It is less expensive.

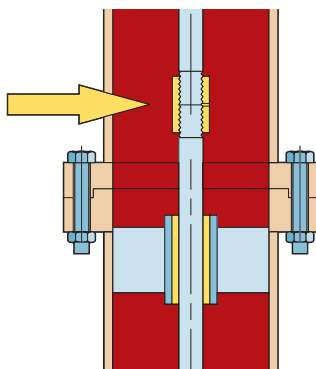

## Keyed Lineshaft

Keyed lineshaft coupling is recommended for motors larger than 500 HP. It provides ease of maintenance.

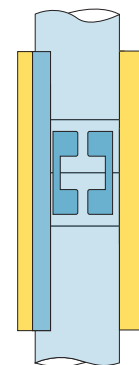



# Goulds Vertical Turbine Pumps

## Coupling Arrangements

### RIGID FLANGED COUPLING (Type AR)

To couple pump to vertical hollow shaft driver. Impeller adjustment is performed on adjusting nut located on top of motor.

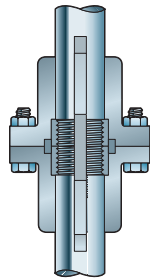

### ADJUSTABLE COUPLING (Type A)

For vertical solid shaft driver, I. C. Impeller adjustment made by using adjustable plate in the coupling.

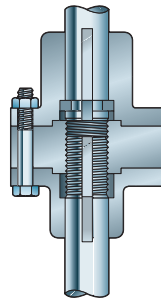

### ADJUSTABLE SPACER COUPLING (Type AS)

Same function as Type A coupling with addition of spacer. Spacer may be removed for mechanical seal maintenance without disturbing driver.

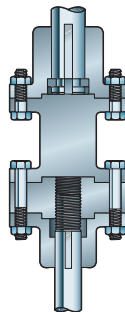

## Discharge Heads

The discharge head functions to change the direction of flow from vertical to horizontal and to couple the pump to the system piping in addition to supporting and aligning the driver. Discharge head accommodates all modes of drivers including hollow shaft and solid shaft motors, right angle gears, vertical steam turbines, etc. Optional sub-base can be supplied. Goulds offers three basic types for maximum flexibility.

### FABRICATED DISCHARGE HEAD

For pressures exceeding cast head limitations or services that require alloy construction such as high or low temperature or corrosive services. Segmented elbow available for efficiency improvement. Large hand holes for easy access. Base flange can be machined to match ANSI tank flange. Bearing at base of discharge head for better shaft support.

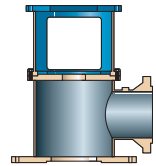

### VIC-T

VIC-T can also be supplied as a VIC-L with the pump suction in the can.

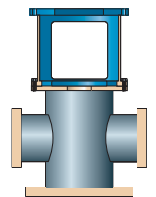

### BELOW GROUND DISCHARGE HEAD

Use whenever VIT pump is required to adapt to an underground discharge system.

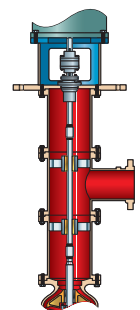

# Sealing Flexibility



## Packed Box With Sleeve Open Lineshaft

Whenever packing lubrication leakage can be tolerated and the discharge pressure does not exceed 150 psi, a packed box may be used. Optional headshaft sleeve available to protect shaft.

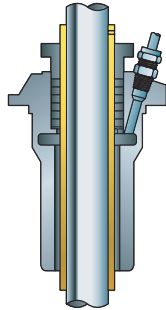

## Single Seal

Most popular method — used for low to medium pressures. Cartridge style for ease of installation and maintenance.

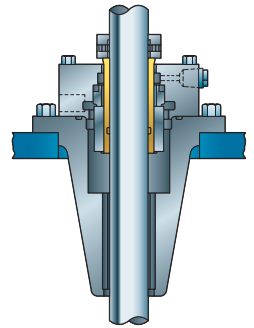

## Water Flush Enclosed Lineshaft

Water flush tube connection is supplied when pressurized water is introduced into the enclosing tube for bearing protection on abrasive services.

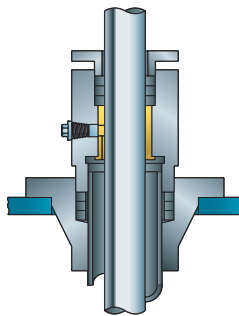

## Outside Mounted Seals

Provides a method of no-leak sealing for low pressure and water application.

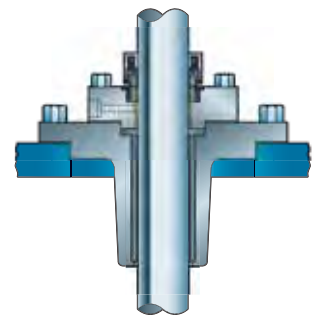

## Oil Lubricated Enclosed Lineshaft

Oil lubricated option is recommended when water elevation would cause the upper lineshaft bearings to run without lubrication during start-up. Oil is fed through tapped opening and allowed to gravitate down enclosing tube to lubricate bearings.

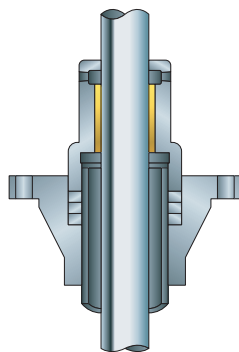

## Dual Seals

Two seals mounted in-line. Chamber between seals can be filled with a buffer liquid and may be fitted with a pressure sensitive annunciating device for safety.

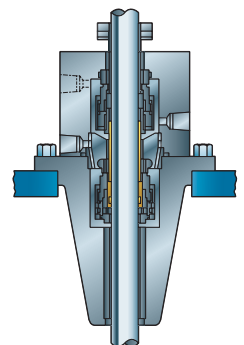



# Model VIT-FF

## Vertical Industrial Turbine Pump

- Flows to 70,000 GPM (15,900 m<sup>3</sup>/Hr)
- Heads to 3,500 feet (1,060 m)
- Pressures to 2,500 psi (75kg/cm<sup>2</sup>)
- Bowl sizes from 6" to 55" (152.4 mm to 1.4 m)
- Temperatures to 500° F (260° C)
- Horsepower to 5,000 HP (1860 KW)

## Design Advantages

- Fabricated discharge head and flanged column
- Flanged bowl construction
- 416SS shafting
- Alloy construction with external flush of critical wear areas available for corrosive/abrasive services
- Built-in alignment and simple piping for less costly installation and ease of maintenance / reduced downtime

## Services

- Cooling Water
- Seawater and River Water Intake
- Industrial Process Pumps
- Utility Circulating Water
- Condenser Circulating Water Pumps
- Ash Sluice





# Cross Sectional

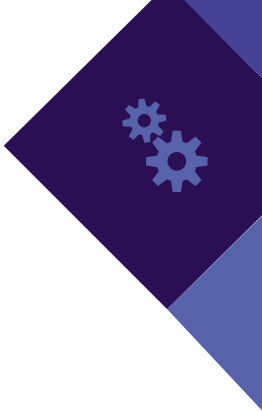

## VIT-FF (Product Lube) TYPICAL MARKETS SERVED

- Power Generation
- Mining
- Municipal
- General Industry
- Chemical

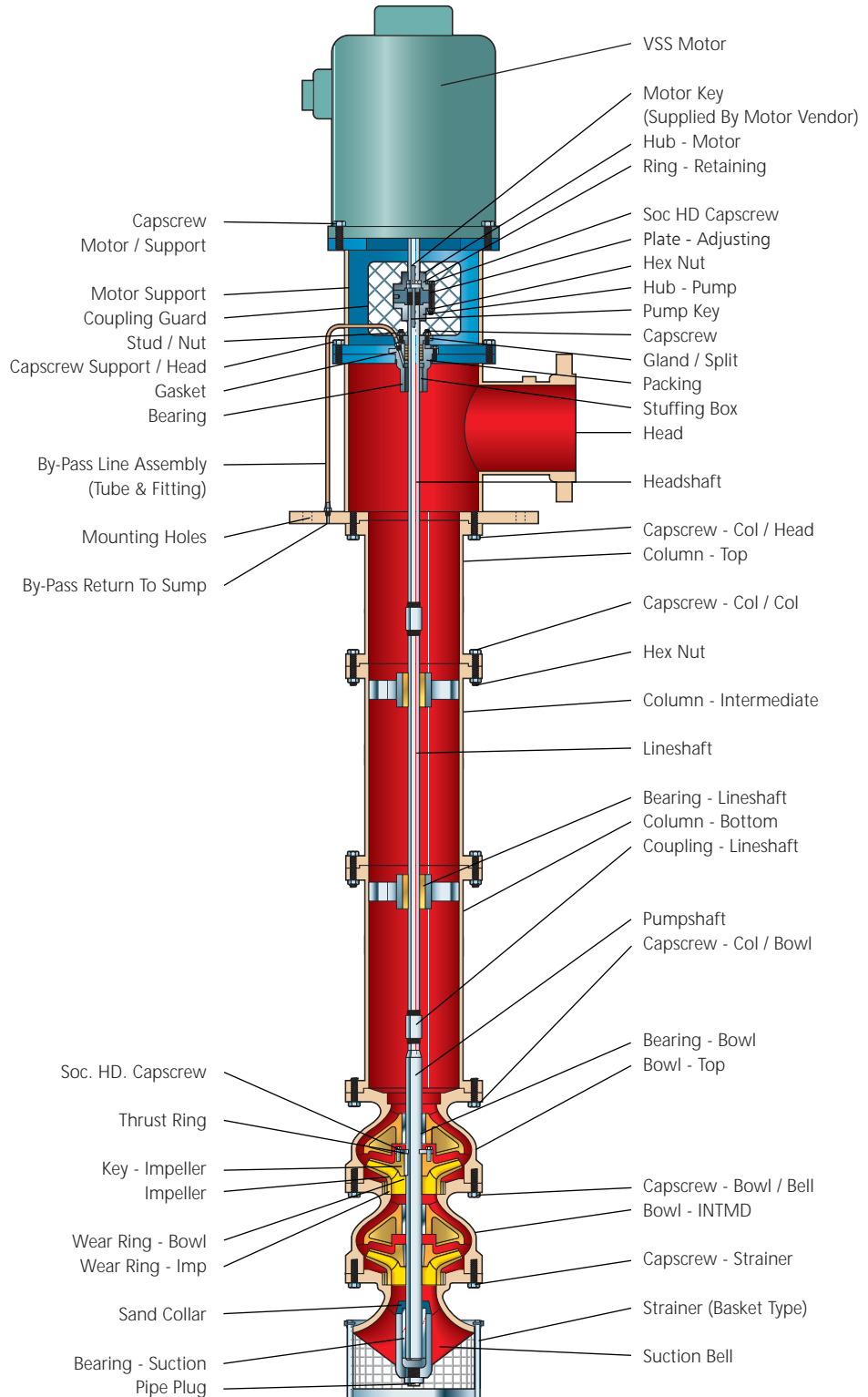



# Cross Sectional

## VIT-FF (Enclosed Lineshaft)

### TYPICAL MARKETS SERVED

- Mining
- Municipal
- Power Generation
- General Industry
- Chemical

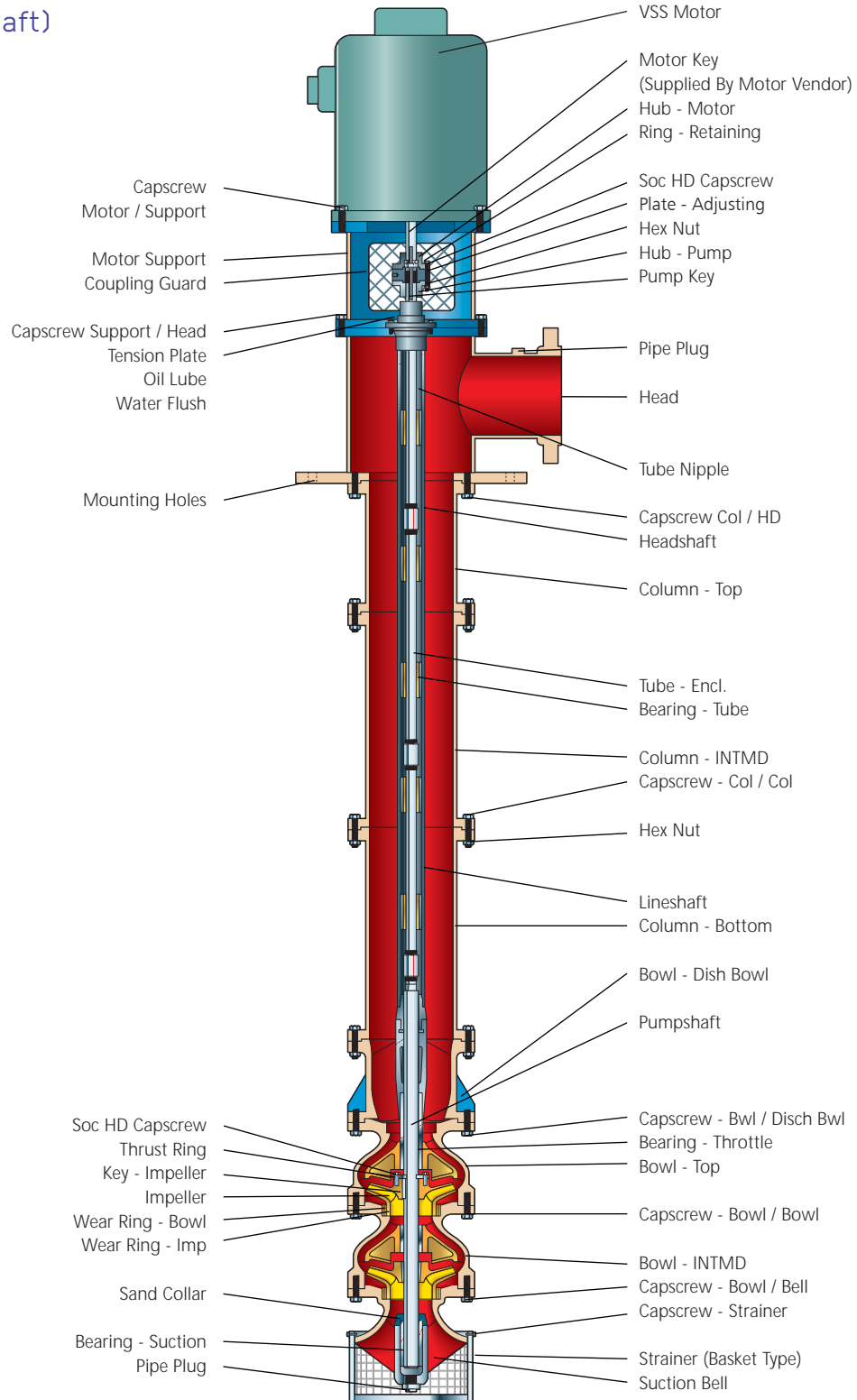

# Model VIC



## Vertical Industrial Can-Type Pump

- Flows to 70,000 GPM (4760 m<sup>3</sup>/Hr)
- Heads to 3,500 feet (1,060 m)
- Pressures to 2,500 psi (75kg/cm<sup>2</sup>)
- Bowl sizes from (0.5 to .4 m)
- Temperatures to 500° F (260° C)
- Horsepower to 5,000 HP (1860 KW)

## Design Advantages

- Fabricated discharge head and flanged column
- Flanged bowl construction
- 416SS shafting
- In-Line suction and discharge simplifies installation
- Optional suction in can for flexibility
- Inherent design features on Model VIC allow efficient operation at any NPSH available
- Alloy construction for corrosive / abrasive services
- Refer to pages 5 and 6 for additional bowl assembly features / options

## Services

- Pipeline Booster
- Product Unloading, Refinery Blending
- Injection Secondary Recovery
- Ammonia Transfer
- Boiler Feed
- Condensate
- Cryogenics
- LNG Transfer



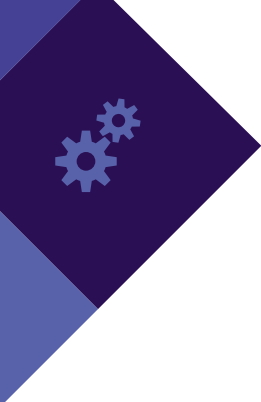

# Cross Sectional

## VIC-T

### TYPICAL MARKETS SERVED

- Power Generation
- Chemical
- Hydrocarbon Processing
- General Industry

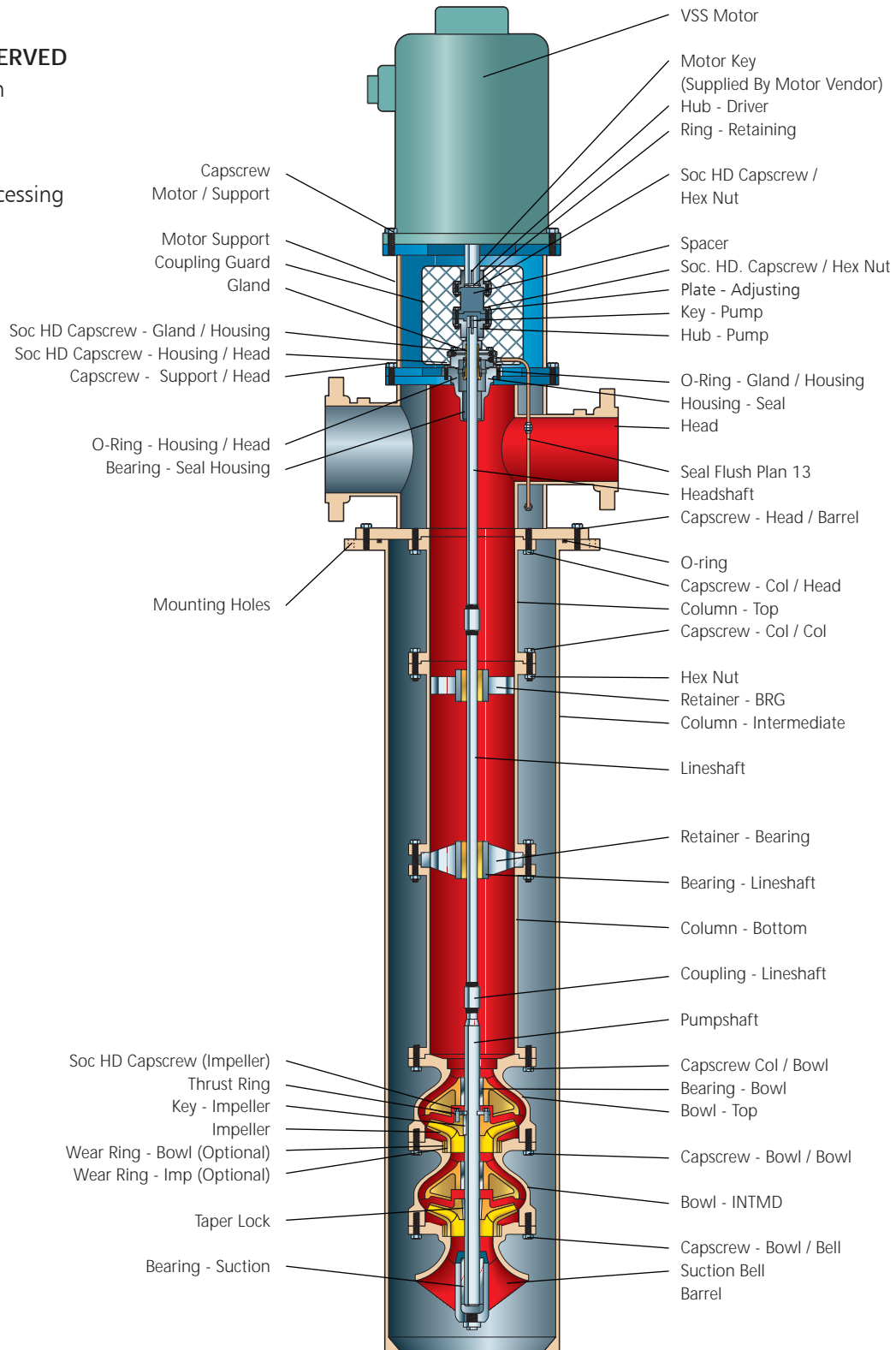

# Cross Sectional



## VIT-T (Per API-610 10th Edition)

### TYPICAL MARKETS SERVED

- Hydrocarbon Processing
- Chemicals
- General Industry

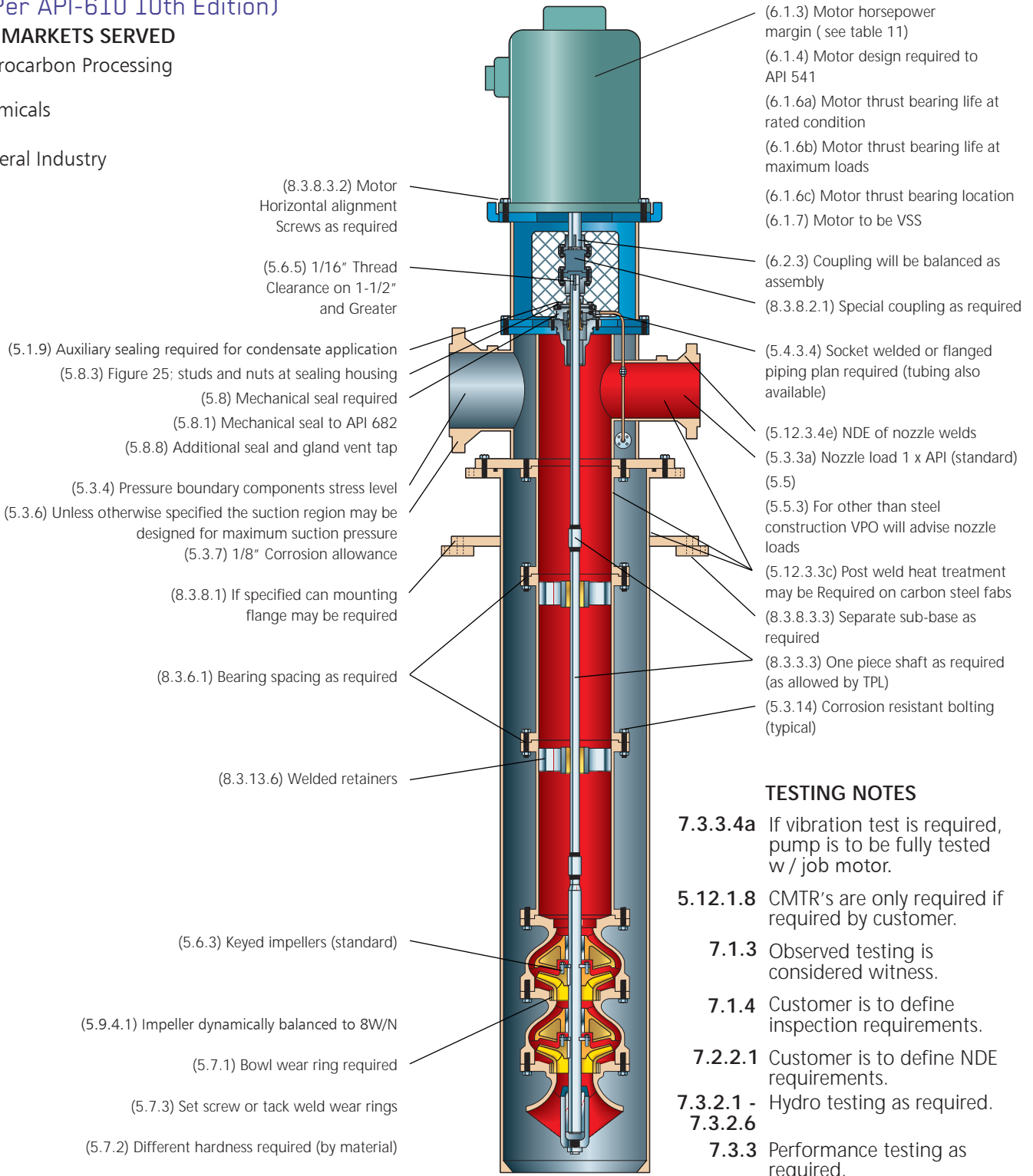

(8.3.8.3.2) Motor Horizontal alignment Screws as required

(5.6.5) 1/16" Thread Clearance on 1-1/2" and Greater

(5.1.9) Auxiliary sealing required for condensate application

(5.8.3) Figure 25; studs and nuts at sealing housing

(5.8) Mechanical seal required

(5.8.1) Mechanical seal to API 682

(5.8.8) Additional seal and gland vent tap

(5.3.4) Pressure boundary components stress level

(5.3.6) Unless otherwise specified the suction region may be designed for maximum suction pressure

(5.3.7) 1/8" Corrosion allowance

(8.3.8.1) If specified can mounting flange may be required

(8.3.6.1) Bearing spacing as required

(8.3.13.6) Welded retainers

(5.6.3) Keyed impellers (standard)

(5.9.4.1) Impeller dynamically balanced to 8W/N

(5.7.1) Bowl wear ring required

(5.7.3) Set screw or tack weld wear rings

(5.7.2) Different hardness required (by material)

(6.1.3) Motor horsepower margin ( see table 11)

(6.1.4) Motor design required to API 541

(6.1.6a) Motor thrust bearing life at rated condition

(6.1.6b) Motor thrust bearing life at maximum loads

(6.1.6c) Motor thrust bearing location

(6.1.7) Motor to be VSS

(6.2.3) Coupling will be balanced as assembly

(8.3.8.2.1) Special coupling as required

(5.4.3.4) Socket welded or flanged piping plan required (tubing also available)

(5.12.3.4e) NDE of nozzle welds

(5.3.3a) Nozzle load 1 x API (standard)

(5.5)

(5.5.3) For other than steel construction VPO will advise nozzle loads

(5.12.3.3c) Post weld heat treatment may be Required on carbon steel fabs

(8.3.8.3.3) Separate sub-base as required

(8.3.3.3) One piece shaft as required (as allowed by TPL)

(5.3.14) Corrosion resistant bolting (typical)

### TESTING NOTES

- 7.3.3.4a** If vibration test is required, pump is to be fully tested w / job motor.
- 5.12.1.8** CMTR's are only required if required by customer.
- 7.1.3** Observed testing is considered witness.
- 7.1.4** Customer is to define inspection requirements.
- 7.2.2.1** Customer is to define NDE requirements.
- 7.3.2.1 - 7.3.2.6** Hydro testing as required.
- 7.3.3** Performance testing as required.



# Model VIS

## Vertical Industrial Turbine Pump

- Flows to 40000 GPM (9,000 m<sup>3</sup>/Hr)
- Heads to 1,400 feet (427 m)
- Pressures to 2500 psi (75kg/cm<sup>2</sup>)
- Bowl sizes from 6" to 50" (152.4 mm to 1.27 m)

## Design Advantages

- Ideal for deep set applications where use of lineshaft pumps is impractical
- Complete unit is installed underground, resulting in quiet operation and space saving
- Long life / low maintenance – no lubrication, alignment

## Services

- Irrigation
- Service Water
- Deep Well



# Cross Sectional

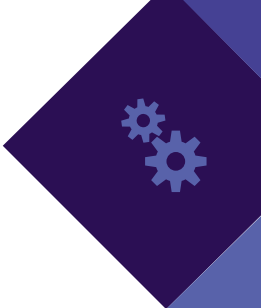

## VIS

### TYPICAL MARKETS SERVED

- General Industry
- Municipal
- Hydrocarbon Processing

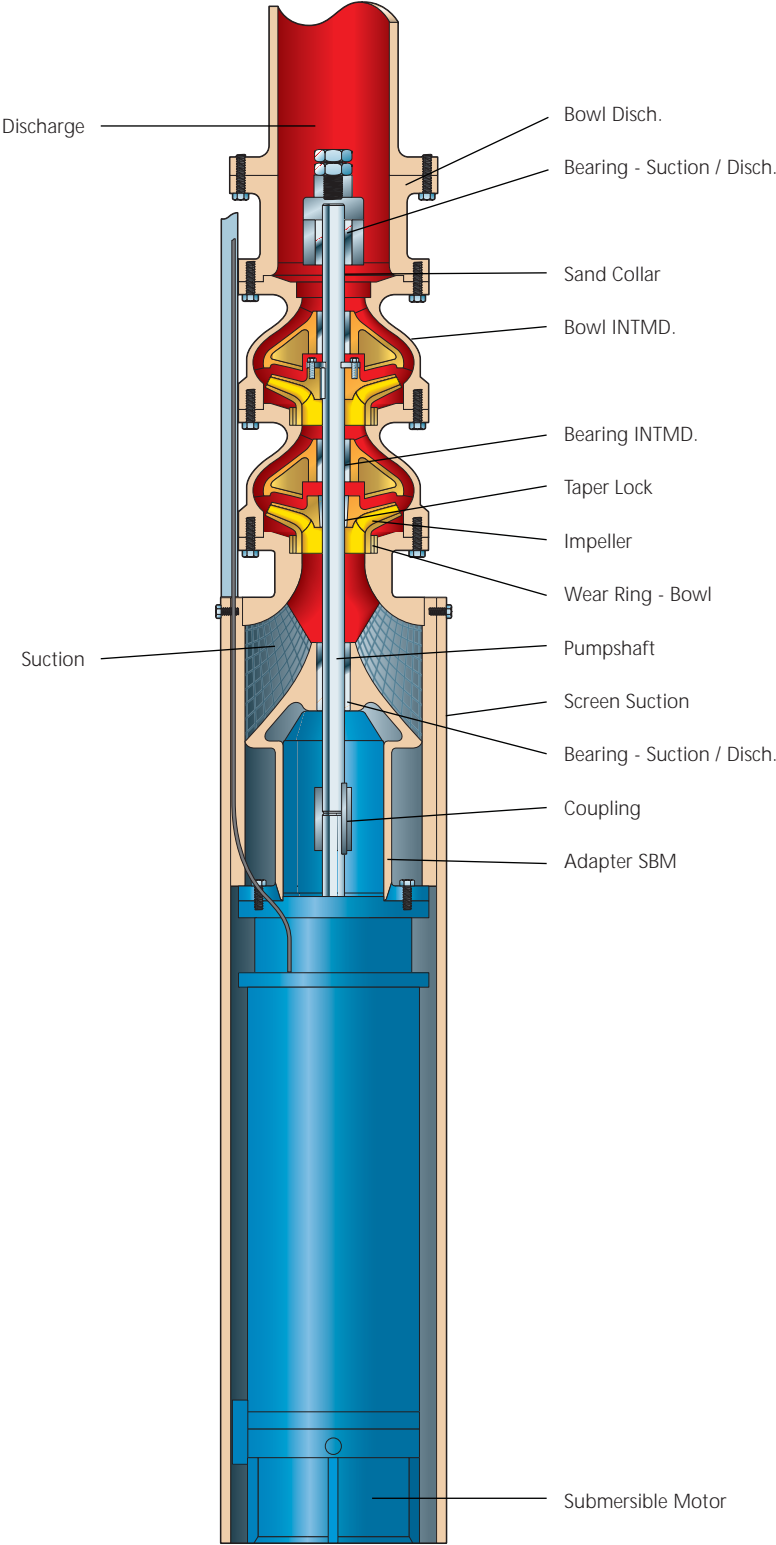



# Hydraulic Coverage

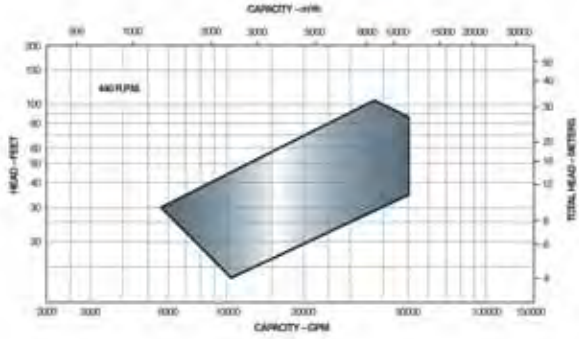
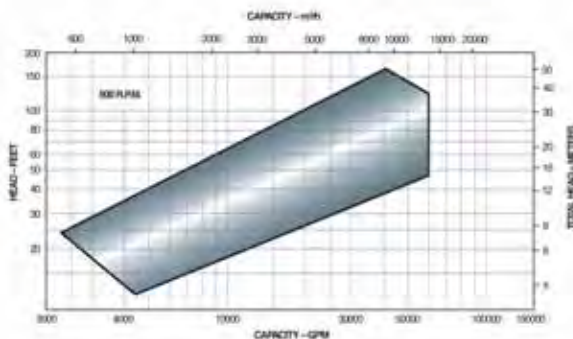
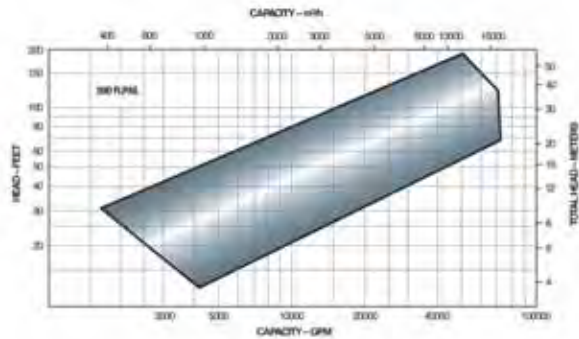
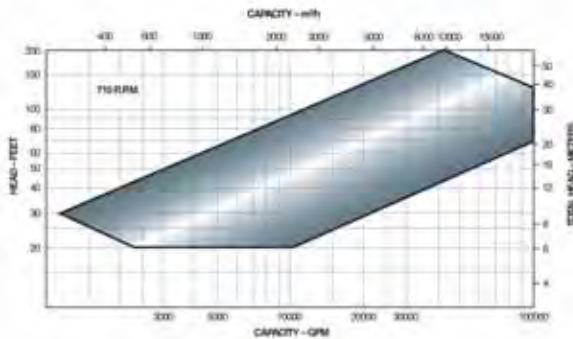
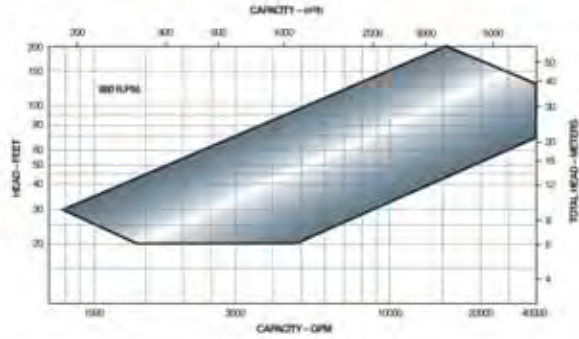
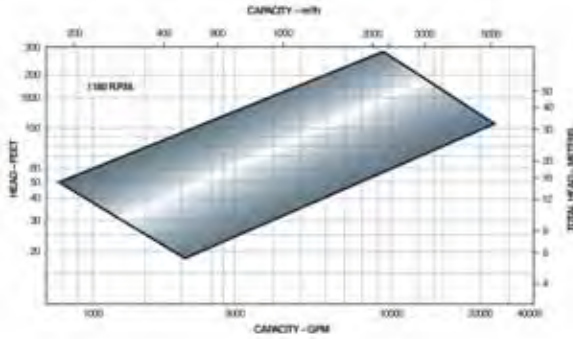
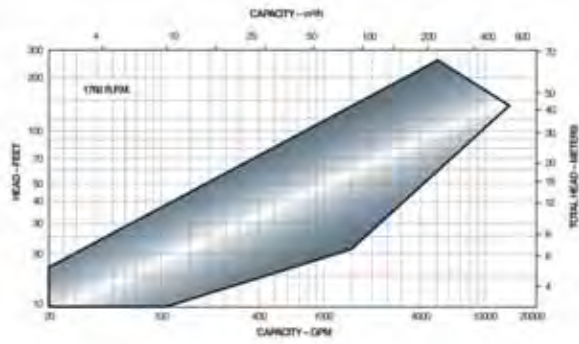
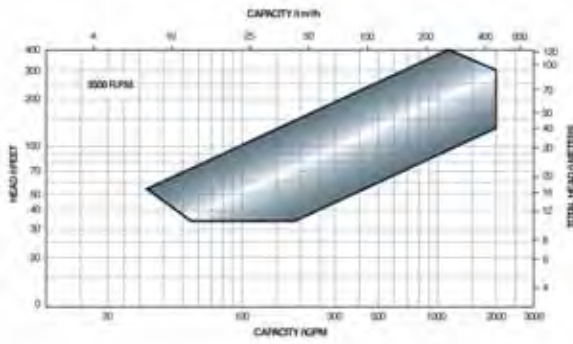

\* Head is per stage.



# Model WCAX, YDD, WCA and WCB

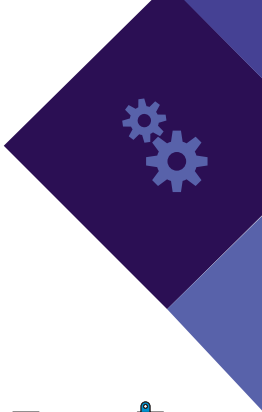

## Design Options and Features Provide Important Cost Savings Benefits

Available as an option on all ITT A-C Pump wet-pit pumps, the “pullout” design reduces maintenance costs and downtime as the discharge piping remains undisturbed when removing the pump.

The unique hydraulic thrust relief design (achieved by opening an area behind the impeller to the outside of the pump) results in low thrust values from maximum flow to shutoff head. This reduces the cost of the driver by reducing the size of the required thrust bearing.

To reach high pressure heads the pumps can be arranged for up to a three stage configuration. ITT A-C Pump’s advanced hydraulic designs provide some of the highest efficiency pumps available in the pumping industry.

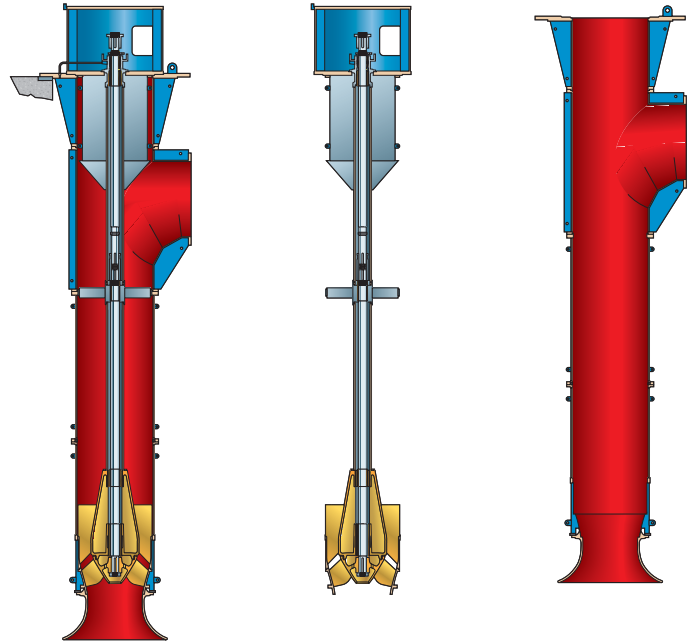

**RANGE CHART**

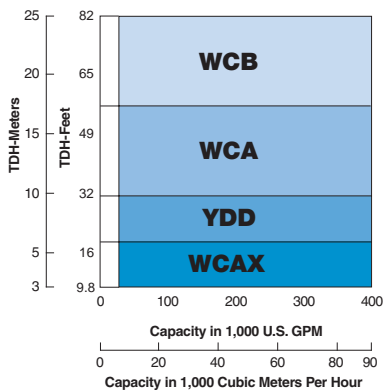



# Model WMCC-WMCE

## Vertical Wet Pit Pumps Offer Maximum Flexibility

The vertical wet pit column pump is the backbone of flood control applications. It has the capability of operating over a wide range of heads, varying suction water levels, and requires a minimum of floor space.

ITT A-C Pump offers several specific speed designs in the axial and mixed flow ranges to meet an array of customer requirements. Mechanical designs are heavy-duty for long life and reliability.

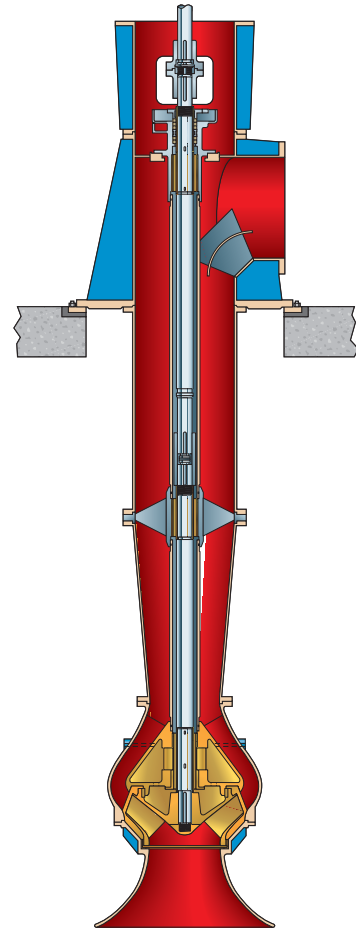
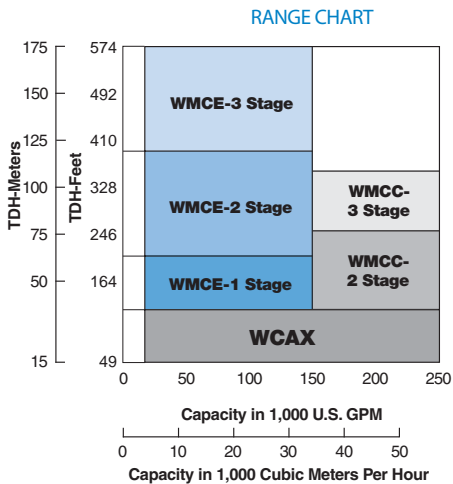

# Special Service Pumps



## Goulds Model VIT and VIC Designed and Built to Meet API-610 Specifications

The design of Vertical API Pumps includes all features required by API-610 for the total range of petroleum services.

In addition to meeting API-610, Goulds offers options that exceed API-610 specifications such as .002" shaft runout at 1,800 RPM and below, hard-facings for shaft and bearings, ultrasonic inspection of shafts, and selection of high alloy materials.

For additional information, ask for "Goulds Vertical Turbine Pumps for API-610 Services."



## Goulds Model VIC for Condensate Service

Transferring hotwell condensate is a demanding service. In addition, utilities expect a pump that provides long life with low maintenance. For these reasons, Goulds Model VIC has proven ideal for condensate service.

Goulds offers hydraulic designs to meet the complete range of condensate pump requirements. Also, a specially designed low NPSH first stage impeller or double suction first stage are available. This reduces required pump length, increases mechanical reliability, and requires less maintenance and downtime.



## Goulds Models VIT and VIS for Sea Water Service Pumps

Goulds Models VIT and VIS are commonly used in oil production platforms.

Model VIT serves as a firewater pump and VIS as a sea water lift pump.

Goulds offers a variety of material selection to sustain the corrosive characteristic of sea water depending on type of service. Whether it is continuous, intermittent or required for service life of equipment.



# PRO services

## Reliability has no quitting time.

Building on over 160 years of Goulds Pumps experience, **PRO Services** provides an array of services focused on reducing equipment total cost of ownership (TCO) and increasing plant output, including predictive monitoring, maintenance contracts, field service, engineered upgrades, inventory management, and overhauls for pumps and other rotating equipment.

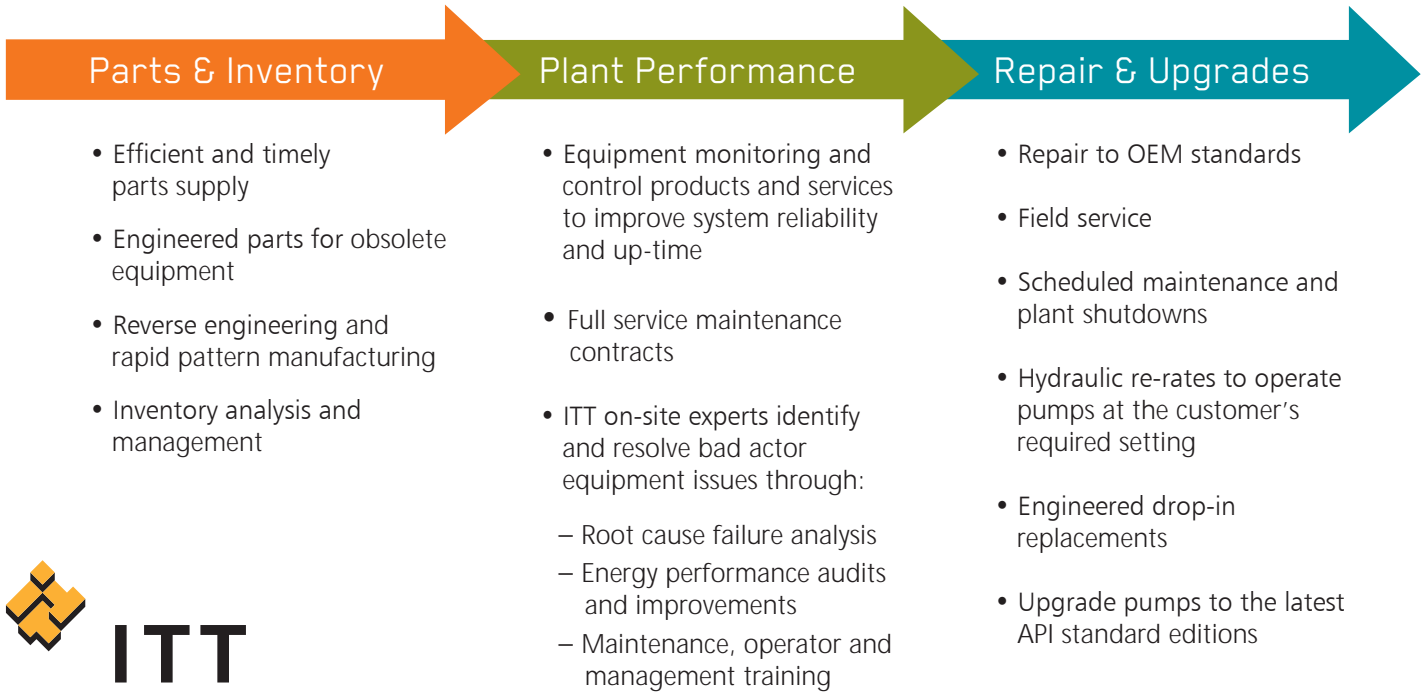
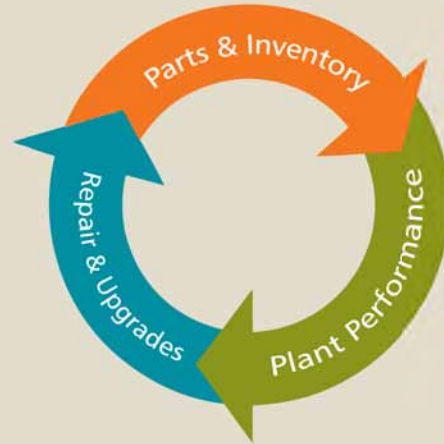

### Parts & Inventory

- Efficient and timely parts supply
- Engineered parts for obsolete equipment
- Reverse engineering and rapid pattern manufacturing
- Inventory analysis and management

### Plant Performance

- Equipment monitoring and control products and services to improve system reliability and up-time
- Full service maintenance contracts
- ITT on-site experts identify and resolve bad actor equipment issues through:
  - Root cause failure analysis
  - Energy performance audits and improvements
  - Maintenance, operator and management training

### Repair & Upgrades

- Repair to OEM standards
- Field service
- Scheduled maintenance and plant shutdowns
- Hydraulic re-rates to operate pumps at the customer's required setting
- Engineered drop-in replacements
- Upgrade pumps to the latest API standard editions



ENGINEERED FOR LIFE