

 **GOULDS PUMPS**

# Goulds XHD

Extra Heavy Duty World-Class Lined Slurry Pumps



**avrorarm.ru**  
**+7 (495) 956-62-18**



**ITT**

ENGINEERED FOR LIFE

# Proven Leader

## **Proven Leadership**

- 100 years of slurry pumping experience
- Many industry firsts including: hard metal slurry pump, rubber lined pump and expeller / dynamic seal.

## **Industry Leading Coverage**

ITT Goulds Pumps offers the most complete line of products for the mining industry, including slurry, process and water pumps, valves, monitoring and control, and a full range of aftermarket and repair services.

## **Reliability**

Due to our extensive portfolio for the mining industry we can provide the right pump for your service regardless of the application, thus maximizing your reliability. ITT Goulds Pumps provides your complete pumping solution.

## **Global Coverage**

With sales offices, packaging and service centers located globally, ITT Goulds Pumps provides the coverage needed to serve our customers, whether small or multi-national companies located in any region.



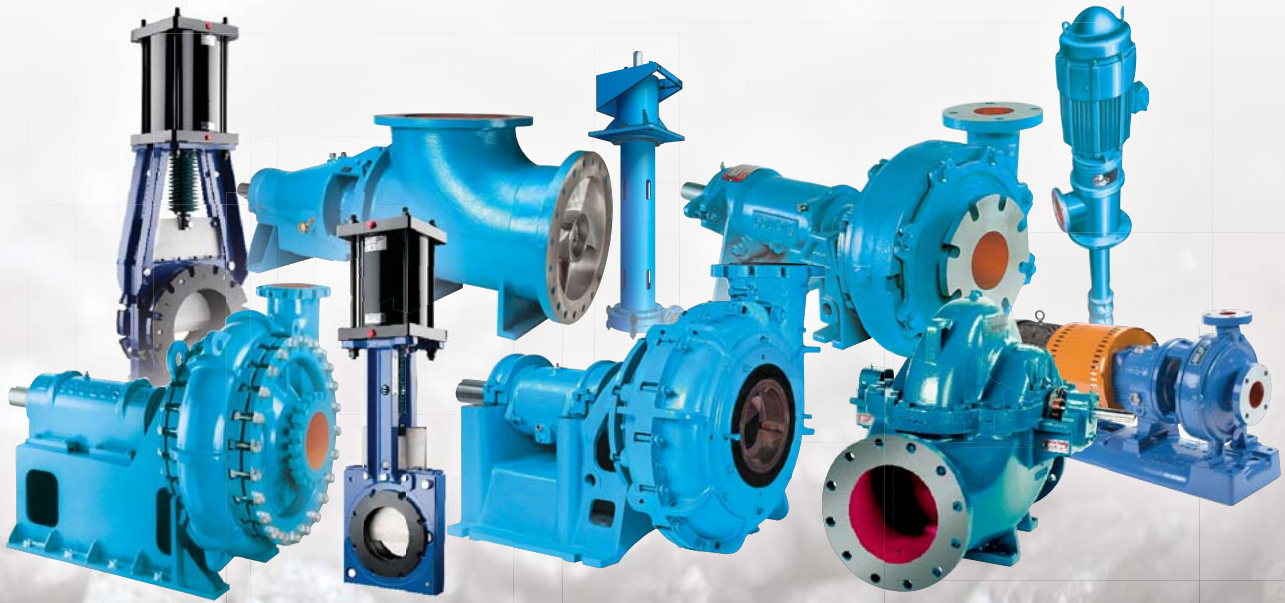

ITT has provided pumping solutions to all types of mineral processing sites throughout the world for well over one hundred years.

We know that only “up-time” yields money and is paramount to our customers. The XHD, engineered to maximize up-time, expands the breadth of our mineral processing solutions portfolio and further complements the complete solutions that our experienced team can provide. We maximize the performance of your processing plants from start to finish.



## Goulds XHD

Extra Heavy Duty  
Lined Slurry Pump

Capacities to: 2950 m<sup>3</sup>/h (13,000 GPM)

Heads to: 85 m (280 feet)

Pressures to: 17 bar (250 PSIG)

Temperatures to: 120°C (250°F)

Services:

**Primary Metals:** SAG/Ball Mill, Cyclone Feed, Tailings

**Mineral Processing:** Slurry Transfer, Flotation Cells, Thickener Underflow

**Non-Metallic Mining:** Heavy Media, Cyclone Feed, Raw Coal, Clay, Soda Ash and Phosphate Slurries, Slurry Heater, Slurry Digestion, Hydrate

**Power:** Absorber Recycle, Gas Cooling, Filter Feed, Lime and Ash Slurries

**Sand & Aggregate:** Sand Slurries, Tailings

# Total Cost of Ownership

---

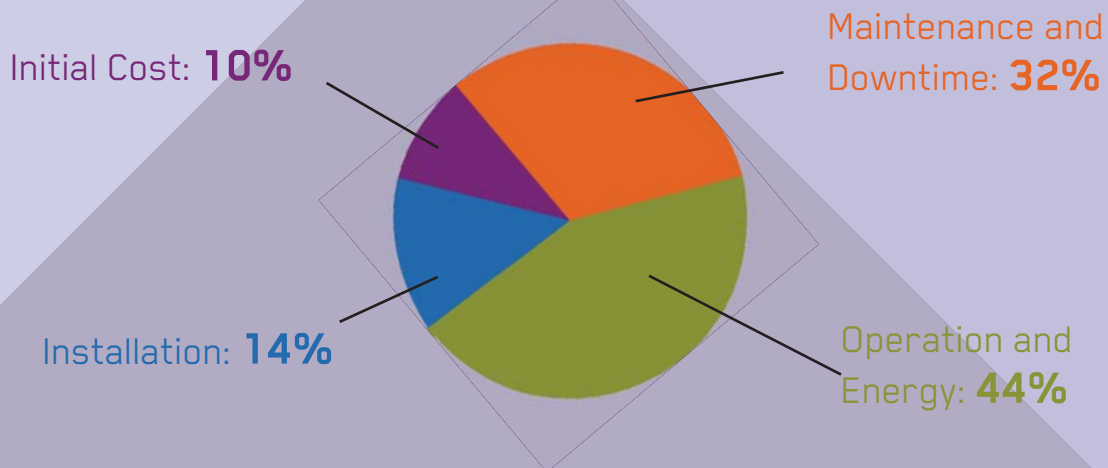

Total Cost of Ownership is the most comprehensive way to identify the true expenses associated with operating and maintaining pumps. Initial price is a small fraction – on average just 10% of what you'll spend to operate the pump over its lifetime. The Goulds XHD is designed to minimize these costs.



Bearing cartridge with machined rails for alignment. Easy to access dual rod adjustment allows you to adjust and maintain performance.



Suction seal ring is adjustable while pump is in operation, allowing you to maintain peak efficiency and performance along with extending wear life. (Patent Pending)

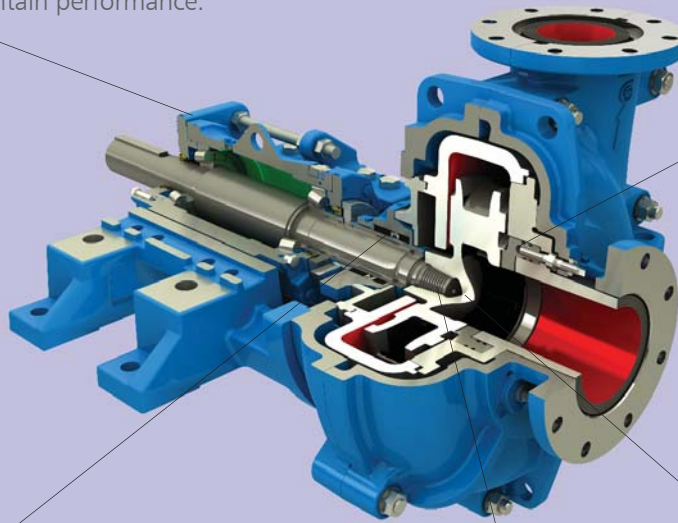

Split stuffing box and gland for quick and easy packing adjustment and replacement.

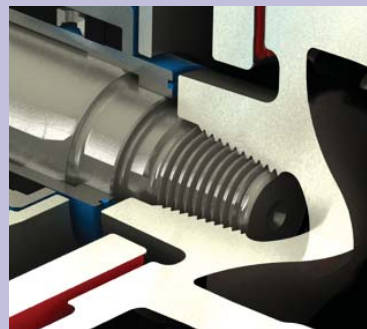

Special tapered impeller thread to facilitate assembly and alignment. (Patent Pending)

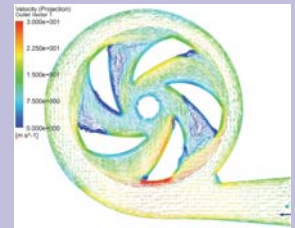

Extensive use of Computational Fluid Dynamics (CFD) analysis for optimal design to maximize efficiency and wear life.

Goulds XHD delivers safety, performance, reliability and ease of maintenance. Because when your slurry pump goes down, production does too.



# Goulds XHD

Extra Heavy Duty World-Class Lined Slurry Pumps

Designed for the toughest slurry applications



Patented **i-Alert™** vibration and bearing temperature monitor.

Easy access dual rod impeller adjustment.

Standard impeller knockoff ring on all sizes and large access openings make maintenance easy.

Bearing Isolators on both end covers keep out dirt and moisture.

Compact pedestal for rigid vibration-free support. Designed to allow retrofit to existing installations. (Patent Pending)

Fully machined slide rails for accurate shaft and bearing cartridge alignment. Designed-in rebuild capability.



Critical frame alignment surfaces protected by frame clamps for years of maintainability, extending life in corrosive mineral processing environments.

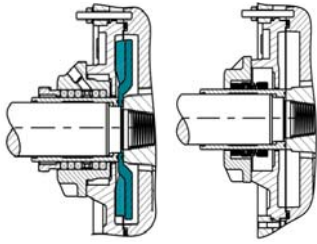

Split stuffing box and gland for easier packing maintenance. Choice of packing, expeller or mechanical seals.

OTHER FEATURES:

CFD designed high efficiency impeller for reduced power and longer wear life

Quick change-out wet end design

Fully confined gaskets

Flanges designed to suit ANSI, ISO and other standards

Flood oil lubrication standard – grease option available

Generous open gland area for easy access

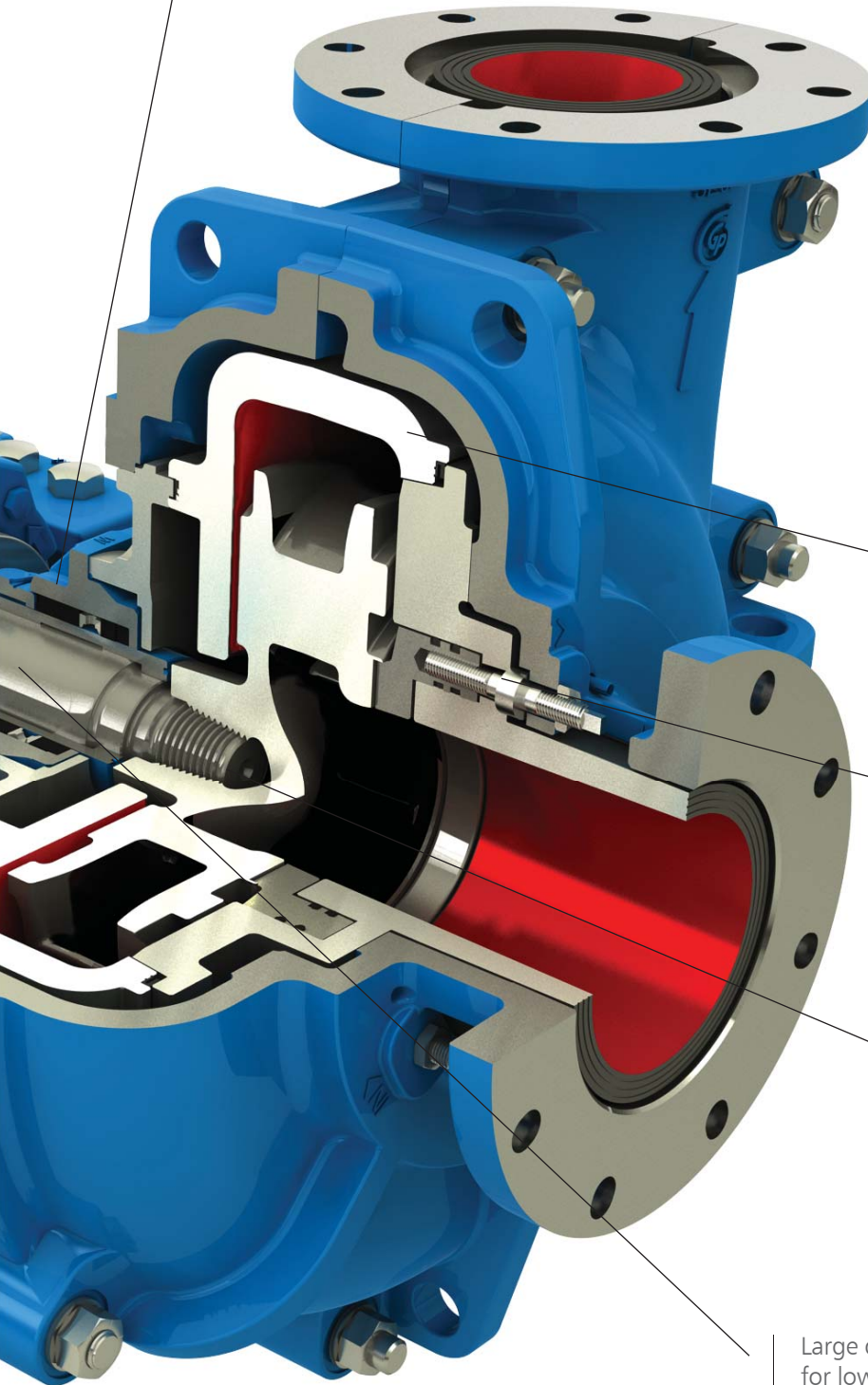

Extra-thick, replaceable, hardened chrome iron liners for extended wear life.

Adjustable seal ring to maintain clearance for peak performance. Can be adjusted while in operation.

Special tapered impeller thread to facilitate assembly and alignment. (Patent Pending)

Large diameter shaft for low deflection.





**The Goulds Model XHD is the result of 100 years of slurry pumping experience.**

The XHD incorporates the latest technology including CFD analysis to provide the next generation in severe-duty slurry pumping. Extensive "Voice of the Customer" input was utilized to insure our customers' most important needs were met. This includes high efficiency with extended wear life, along with maximum reliability and ease of maintenance. The XHD is designed to keep your process running.

Primary Sand Slurry Pump in an Aggregate Plant



Primary Cyclone Feed Pump in a Primary Metals Mill



Heavy Media Cyclone in a Coal Preparation Plant



Thickener Underflow Pump in a Coal Preparation Plant



# Dimensions

Pump Size	Frame Size	Flange Size DIN/ANSI		Dimensions								Shaft Dia.
		Suct.	Disch.	A	B	C	D	E	F	H (3)	J	
80	PF2	100 / 4"	75 / 3"	300	165	210	336	278	1017	350	227	60
125	PF3	150 / 6"	125 / 5"	400	240	275	393	394	1268	405	283	80
150	PF4	200 / 8"	150 / 6"	515	310	360	516	560	1760	502	420	100
200	PF4	250 / 10"	200 / 8"	650	400	435	546	710	1850			
250	PF5	300 / 12'	250 / 10'	725	490	500	667	720	2174	515	490	120
300	PF5	350 / 14"	300 / 12"	925	625	585	732	925	2285			

## Notes:

1. All dimensions in mm.
2. Not for construction, installation, or application purposes.
3. Pedestal width.

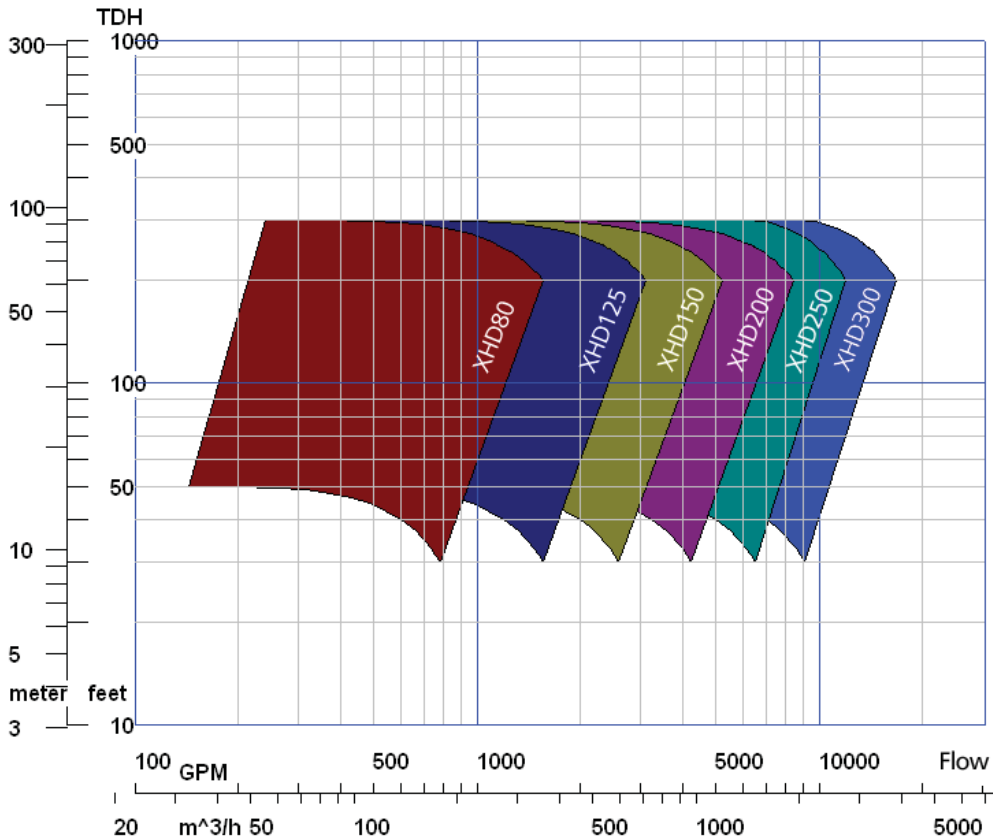
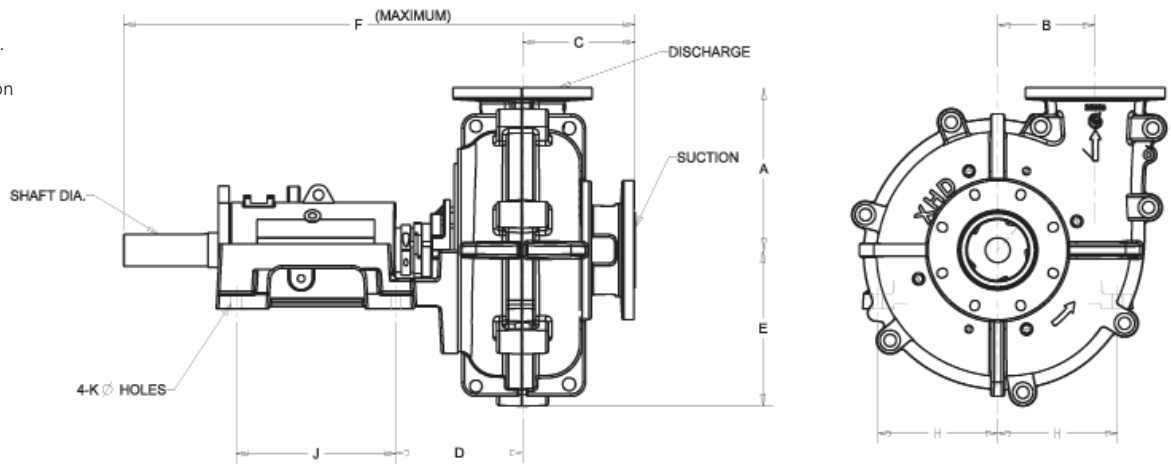

# PRO services

## Reliability has no quitting time.

**ITT PRO Services** provides an array of services focused on reducing equipment total cost of ownership (TCO) and increasing plant output, including predictive monitoring, contract maintenance, field service, engineered upgrades, inventory management, and overhauls for pumps and other rotating equipment.

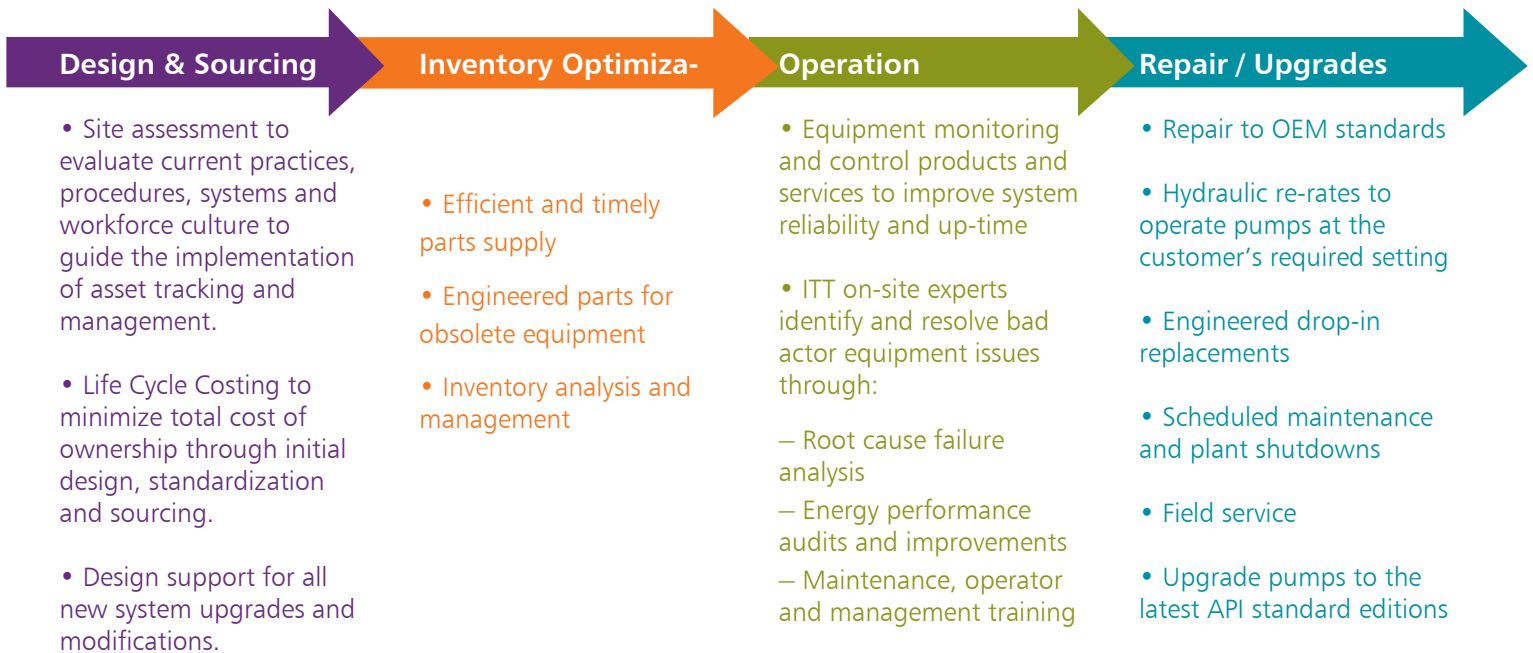
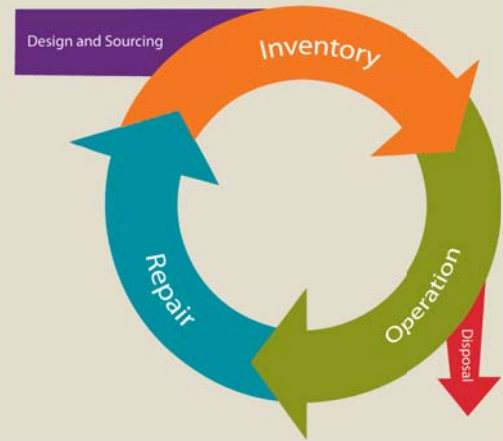



## ITT PRO Services



Design & Sourcing

PPS



Inventory Optimization

PPS, Parts (Goulds Pumps and ProCast)



Operation

PPS, PumpSmart, ProSmart



Repair / Upgrades

PRO Services, Parts (Goulds Pumps and ProCast)

## Total Cost of Ownership