

# B185

The demand for natural refrigerants such as CO2 is increasing. With pressure requirements for transcritical CO2 applications touching 140 bar, the B185 is the natural choice. The B185 is optimized for high heat load capacities (up to 350 kW as a gas cooler). The compact yet lightweight B185 is suitable for cold-chain applications (hypermarkets, supermarkets, heat recovery) and heat pumps (evaporators, gas coolers).



## Basic specifications

Maximum number of plates (NoP)	180
Max flow	38.8 m³/h (170.83 gpm)
Channel volume	0.1106/0.1169 dm³ (0.0039/0.0041 ft³)
Material	316 stainless steel plates, copper brazing
Weight excl. connections	11.33+(0.4366*NoP) kg 24.98+(0.963*NoP) lb

## Standard dimensions

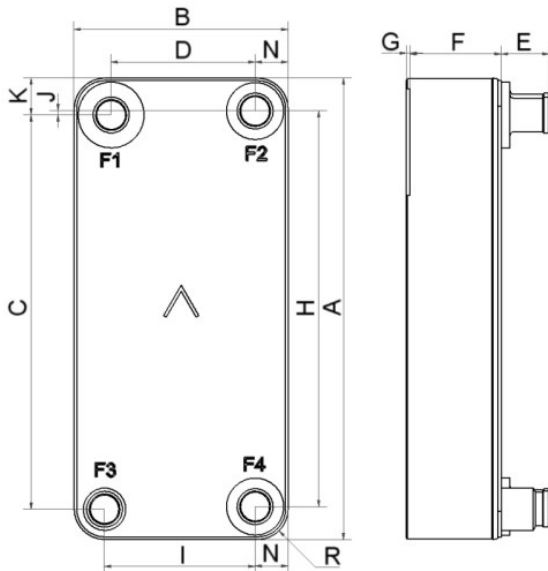

#	MM	IN
A	425.20	16.74
B	203.20	8
C	354	13.94
D	126	4.96
F	18.00+2.00*(NoP)	0.71+0.08*(NoP)
G	0	0
H	342	13.46
J	6	0.24
K	35.60	1.4
N	41.60	1.64
R	41.60	1.64
E_1	45	1.77

## Available connections



Threaded Ultra High Combo Connection Approved

\*For specific dimensions, or information about other types of connections, please contact your SWEP sales representative.

## PED Pressure / Temperature

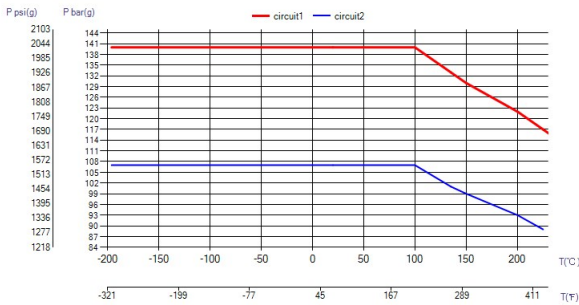

## UL Pressure / Temperature

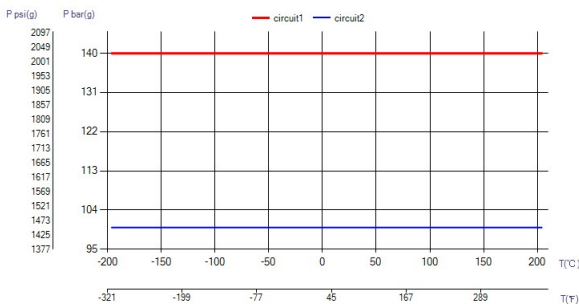

## Product concept

The Brazed Plate Heat Exchanger (BPHE) is constructed as a plate package of corrugated channel plates with a filler material between each plate. During the vacuum brazing process, the filler material forms a brazed joint at every contact point between the plates, creating complex channels. The BPHE allows media at different temperatures to come into close proximity, separated only by channel plates that enable heat from one media to be transferred to the other with very high efficiency. The concept is similar to other plate and frame technology, but without the gaskets and frame parts.

## 3rd party Approvals

Most SWEP products are approved by below listed certification organizations: Europe, Pressure Equipment Directive (PED) America, Underwriters Laboratories Inc (UL) Japan, Kouatsu-Gas Hoan Kyoukai (KHK) Additionally SWEP holds approvals from a vast variety of other certification organizations. For more details please contact your local SWEP representative. SWEP reserves the right to make changes without prior notice.

## Find product solution - SSP

With SWEP's unique SSP, the SWEP Software Package, you can do advanced heat transfer calculations yourself. It's also easy to choose connections and generate drawings of the complete product. If you would like advice, SWEP offers all the service and support you need. Several SWEP accessories are also available to fulfill additional needs.

## Disclaimer

The information and recommendations in regards to the products are presented in good faith, however, SWEP makes no representations or warranties as to the completeness or accuracy of the information. Information is supplied upon the condition that the purchasers will make their own determination as to the products' suitability for their purposes prior to use. Purchasers should note that the properties of the products are both application and material selection dependent and that products containing stainless steel are still object to corrosion if used in unsuitable environments. Standard data is presented, product variants with different data may exist. Contact your SWEP sales representative for more details. SWEP may change any data without notice.