

ADWIS 12 | G2

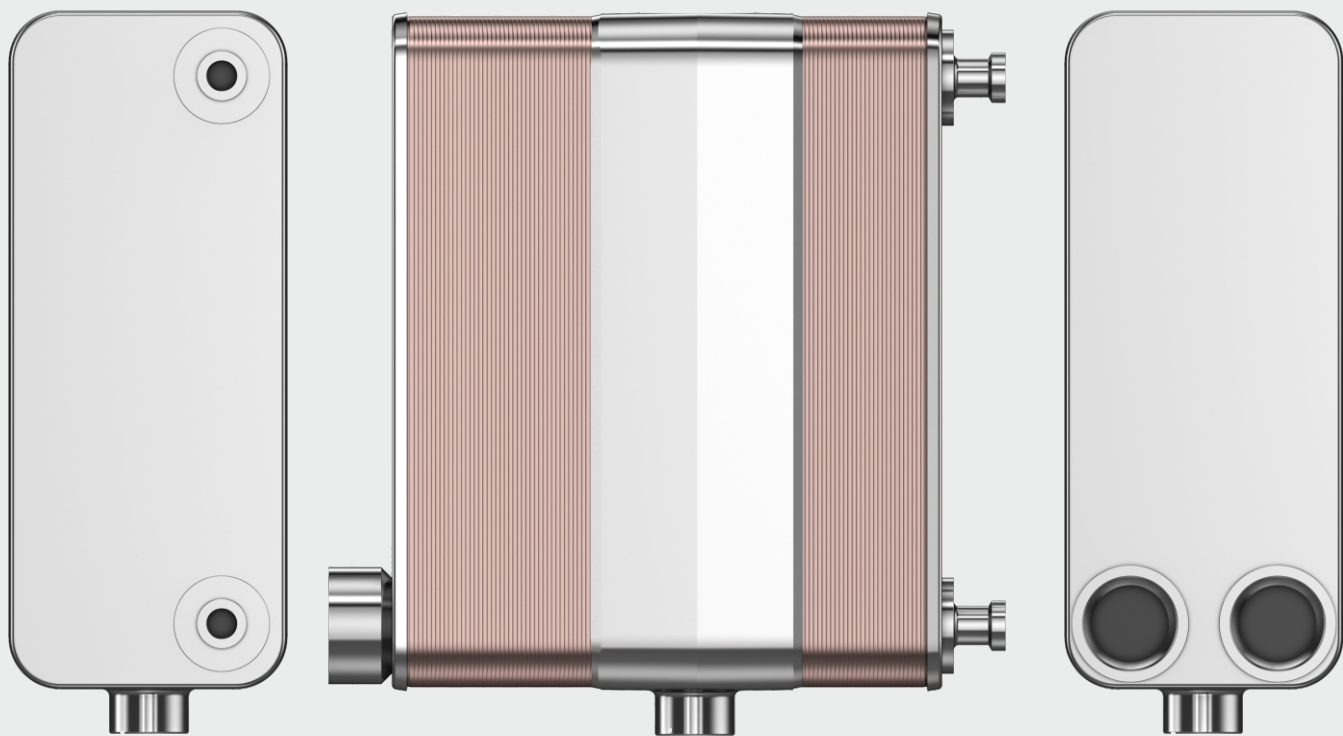

The original ADWIS just got greater: the new 12-series has integrated start plates to minimize material wastage. This robust yet cost-effective solution is suitable for flow rates of up to 235 scfm in a very compact envelope. Other advantages include stable high performance, convenient drainage and high drying efficiency.

ADWIS 12 | G2

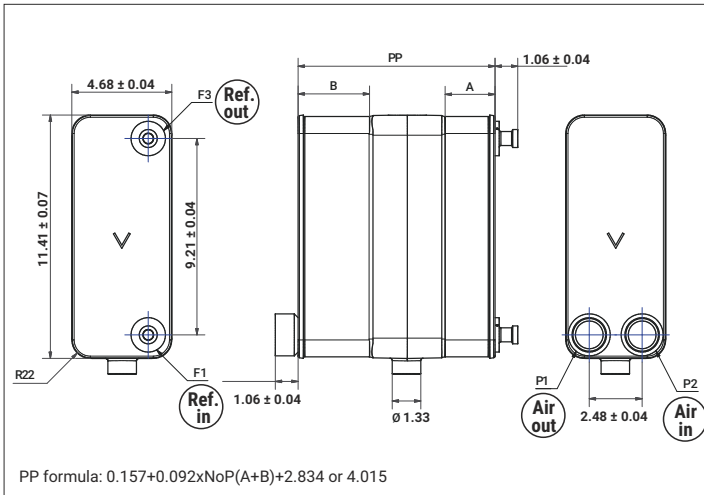

Design specification (ISO class 4)

Air side: $P = 102 \text{ psi(g)}$, $T_{\text{dev}} = 37.4^\circ\text{F}$, $\Delta P = 2.9 \text{ psi}$,
 $T_{\text{in}} = 95^\circ\text{F}$, $T_{\text{out}} = 80.6^\circ\text{F}$
 Refrigerant side: R134a, $T_{\text{evap}} = 32^\circ\text{F}$, $\text{SH} = 9^\circ\text{F}$

Design specification (ISO class 5)

Air side: $P = 102 \text{ psi(g)}$, $T_{\text{dev}} = 44.6^\circ\text{F}$, $\Delta P = 5.8 \text{ psi}$,
 $T_{\text{in}} = 95^\circ\text{F}$, $T_{\text{out}} = 80.6^\circ\text{F}$
 Refrigerant side: R134a, $T_{\text{evap}} = 32^\circ\text{F}$, $\text{SH} = 9^\circ\text{F}$

Max working pressure

Air side: 261 psi(g) @ 68°F
 Refrigerant side: 565 psi(g) @ 68°F
 According to PED

Air side: 232 psi(g)
 Refrigerant side: 449 psi(g)
 According to UL

Material specification

Main parts: Stainless steel
 Brazing material: Copper

Separator efficiency rate

Droplets size: 0,2 mils = 93%; 0,4 mils = 99,9%

Mounting

Stud-bolts available per standard article number: 21712

Article numbers	Air side connections	Refrigerant side connections	Drainage connections
18489-*	Solder 42U	Solder 12,8	3/4" INT
18496-*	ISO-G 1" INT	Solder 12,8	3/4" INT
18535-*	Solder 35,1	Solder 12,8	3/4" INT
18536-*	ISO-G 1 1/4" INT	Solder 12,8	3/4" INT
18537-*	NPT 1 1/4"-11 1/2 INT	Solder 12,8	3/4" INT
18538-*	NPT 1"-11 1/2 INT	Solder 12,8	3/4" INT
18539-*	Solder 42U	Solder 22U	3/4" INT

* NoP available per each article number: 031, 037, 045, 055, 067, 081

	Model	Flow rate (Scfm)	NoP A	NoP B	Refrigerant hold-up volume (ft³) ±3%	Total PP measurement (in)
ISO class 4	ADWIS 150	60 - 90	14	17	0.013	5.9
	ADWIS 200	90 - 120	16	21	0.016	6.4
	ADWIS 250	120 - 145	18	27	0.018	7.1
	ADWIS 300	145 - 175	22	33	0.022	9.2
	ADWIS 350	175 - 205	26	41	0.027	10.3
	ADWIS 400	205 - 235	30	51	0.031	11.6
ISO class 5	ADWIS 150	90 - 120	14	17	0.013	5.8
	ADWIS 200	120 - 145	16	21	0.016	6.4
	ADWIS 300	145 - 220	22	33	0.022	9.2
	ADWIS 350	220 - 235	26	41	0.027	10.3

Flow rate in accordance with ISO 7183 - 20°C and 0 bar(g)

