

ADWIS 12 | G2

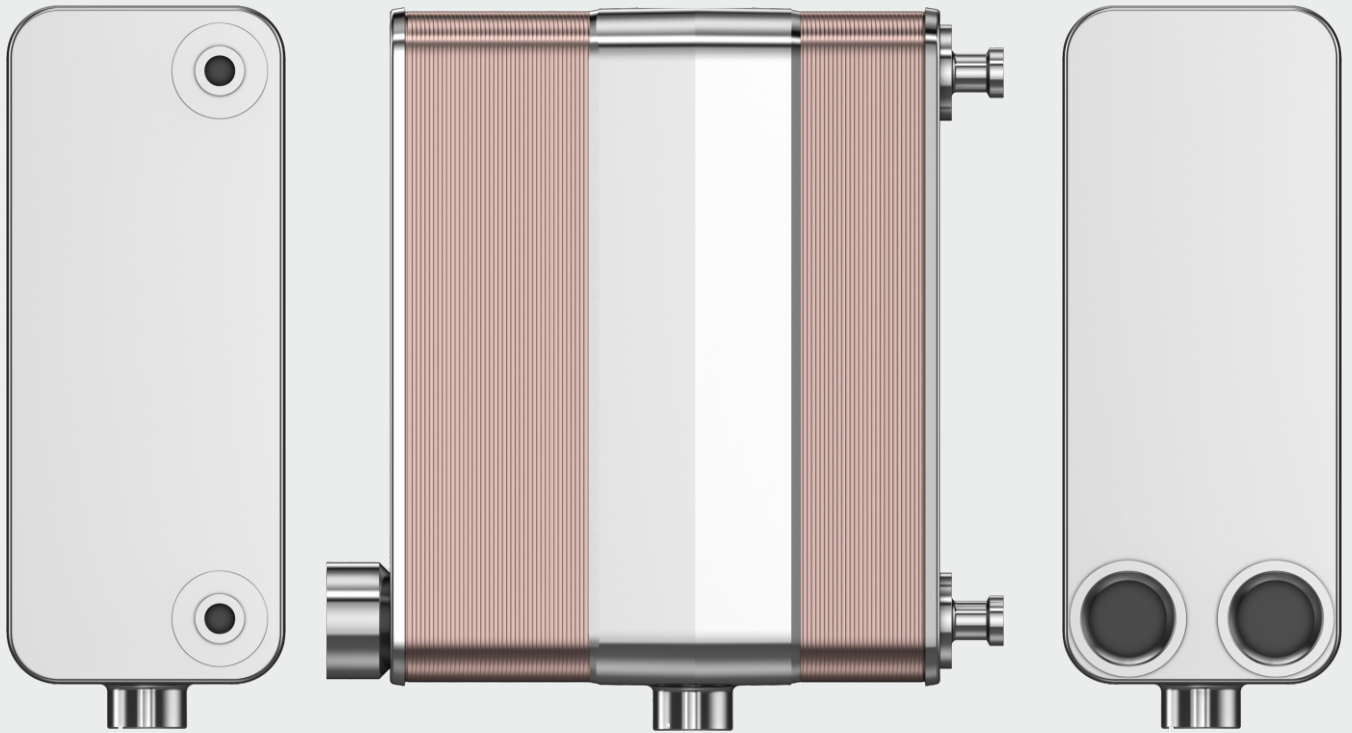

The original ADWIS just got greater: the new 12-series has integrated start plates to minimize material wastage. This robust yet cost-effective solution is suitable for flow rates of up to 400 Nm³/h in a very compact envelope. Other advantages include stable high performance, convenient drainage and high drying efficiency.

ADWIS 12 | G2

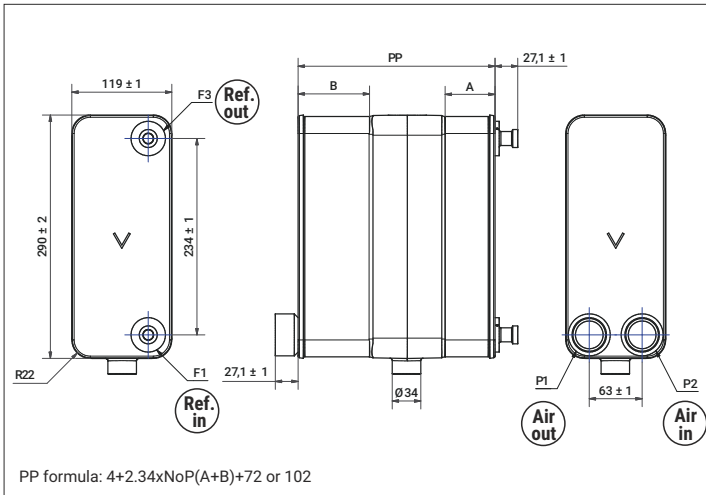

Design specification (ISO class 4)

Air side: P = 7 bar(g), $T_{dew} = 3^{\circ}\text{C}$, $\Delta P = 20\text{ kPa}$,
 $T_{in} = 35^{\circ}\text{C}$, $T_{out} = 27^{\circ}\text{C}$
 Refrigerant side: R134a, $T_{evap} = 0^{\circ}\text{C}$, SH = 5K

Design specification (ISO class 5)

Air side: P = 7 bar(g), $T_{dew} = 7^{\circ}\text{C}$, $\Delta P = 40\text{ kPa}$,
 $T_{in} = 35^{\circ}\text{C}$, $T_{out} = 27^{\circ}\text{C}$
 Refrigerant side: R134a, $T_{evap} = 0^{\circ}\text{C}$, SH = 5K

Max working pressure

Air side: 18 bar(g) @ 20°C
 Refrigerant side: 39 bar(g) @ 20°C
 According to PED

Air side: 16 bar(g)
 Refrigerant side: 31 bar(g)
 According to UL

Material specification

Main parts: Stainless steel
 Brazing material: Copper

Separator efficiency rate

Droplets size: 5 μm = 93%; 10 μm = 99,9 %

Mounting

Stud-bolts available per standard article number: 21712

Article numbers	Air side connections	Refrigerant side connections	Drainage connections
18489-*	Solder 42U	Solder 12,8	3/4" INT
18496-*	ISO-G 1" INT	Solder 12,8	3/4" INT
18535-*	Solder 35,1	Solder 12,8	3/4" INT
18536-*	ISO-G 1 1/4" INT	Solder 12,8	3/4" INT
18537-*	NPT 1 1/4"-11 1/2 INT	Solder 12,8	3/4" INT
18538-*	NPT 1"-11 1/2 INT	Solder 12,8	3/4" INT
18539-*	Solder 42U	Solder 22U	3/4" INT

* NoP available per each article number: 031, 037, 045, 055, 067, 081

	Model	Flow rate (Nm³/h)	NoP A	NoP B	Refrigerant hold-up volume (dm³) ±3%	Total PP measurement (mm)
ISO class 4	ADWIS 150	100 - 150	14	17	0,378	148,5
	ADWIS 200	150 - 200	16	21	0,441	162,6
	ADWIS 250	200 - 250	18	27	0,504	181,3
	ADWIS 300	200 - 300	22	33	0,630	234,7
	ADWIS 350	300 - 350	26	41	0,756	262,8
	ADWIS 400	350 - 400	30	51	0,882	295,5
ISO class 5	ADWIS 150	150 - 200	14	17	0,378	148,5
	ADWIS 200	200 - 250	16	21	0,441	162,6
	ADWIS 300	250 - 375	22	33	0,630	234,7
	ADWIS 350	375 - 400	26	41	0,756	262,8

Flow rate in accordance with ISO 7183 - 20°C and 0 bar(g)

