

ADWIS 5 | G2

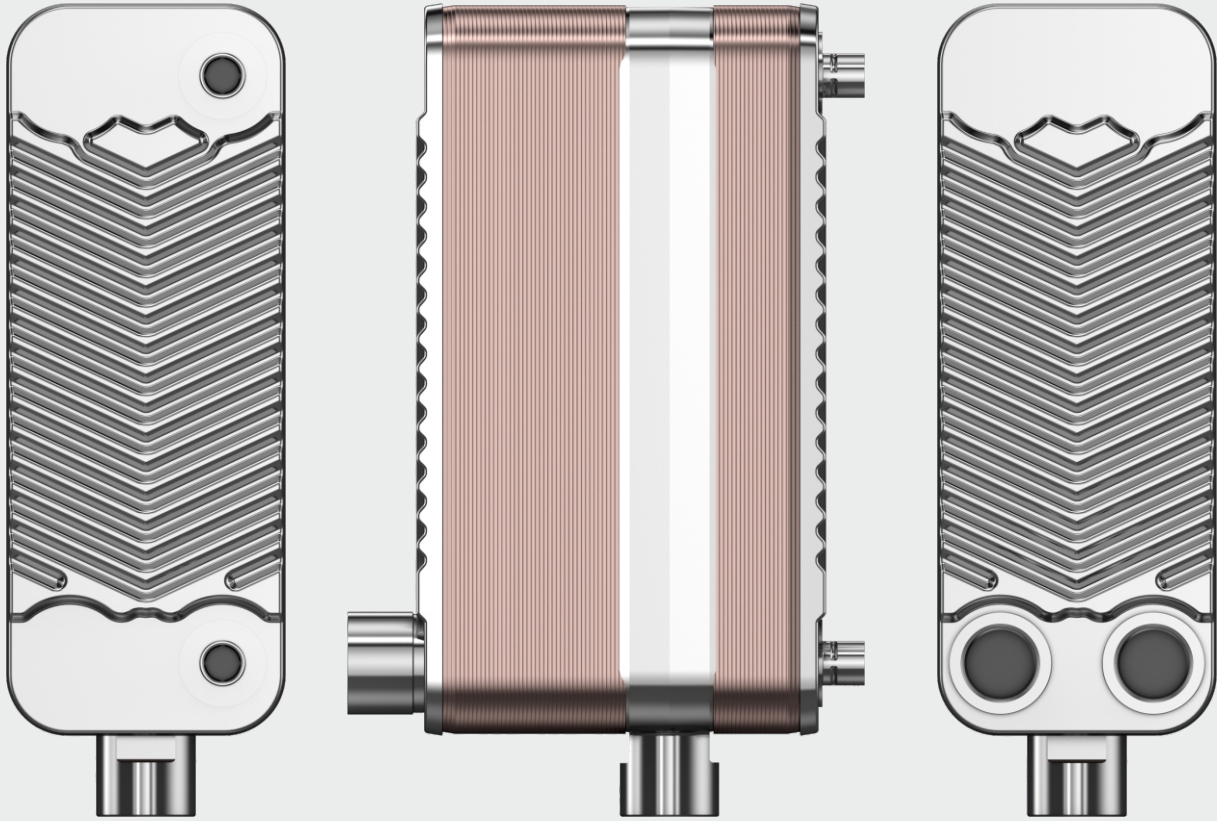

The original ADWIS just got greater: the new 5-series integrates AsyMatrix[®] technology on the refrigerant-to-air side, reducing the increasingly expensive refrigerant charge while maintaining a low pressure drop on the air-side. This robust yet cost-effective solution is suitable for flow rates of up to 60 scfm in a very compact envelope. Other advantages include stable high performance, convenient drainage and high drying efficiency.

CHALLENGE EFFICIENCY

avroro-arm.ru
+7 (495) 956-62-18

SUPER
A DOVER COMPANY

ADWIS 5 | G2

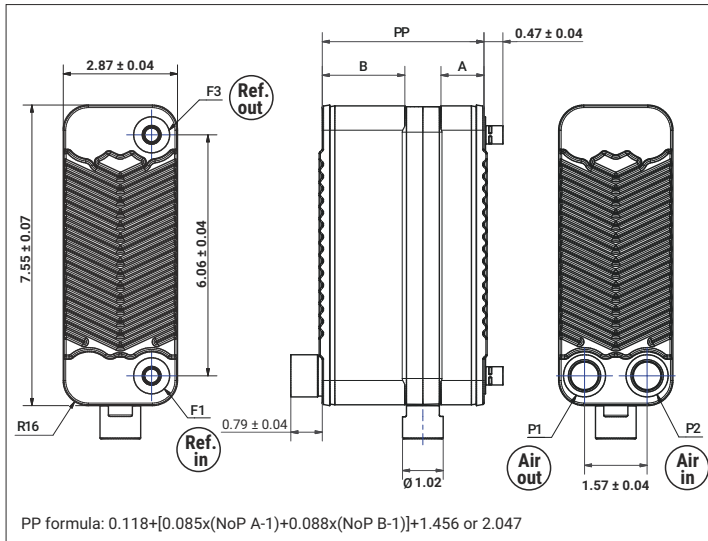

Design specification (ISO class 4)

Air side: P = 102 psi(g), $T_{\text{dew}} = 37.4^\circ\text{F}$, $\Delta P = 2.9$ psi,
 $T_{\text{in}} = 95^\circ\text{F}$, $T_{\text{out}} = 80.6^\circ\text{F}$
 Refrigerant side: R134a, $T_{\text{evap}} = 32^\circ\text{F}$, SH = 9°F

Design specification (ISO class 5)

Air side: P = 102 psi(g), $T_{\text{dew}} = 44.6^\circ\text{F}$, $\Delta P = 5.8$ psi,
 $T_{\text{in}} = 95^\circ\text{F}$, $T_{\text{out}} = 80.6^\circ\text{F}$
 Refrigerant side: R134a, $T_{\text{evap}} = 32^\circ\text{F}$, SH = 9°F

Max working pressure

Air side: 261 psi(g) @ 68°F
 Refrigerant side: 507 psi(g) @ 68°F
 According to PED

Air side: 319 psi(g)
 Refrigerant side: 319 psi(g)
 According to UL

Material specification

Main parts: Stainless steel
 Brazing material: Copper

Separator efficiency rate

Droplets size: 0,2 mils = 93%; 0,4 mils = 99,9 %

Mounting

Stud-bolts available per standard article number: 21727

Article numbers	Air side connections	Refrigerant side connections	Drainage connections
18530*	ISO-G ½" INT	Solder 9,65(DD)	½" INT
18532*	NPT ½"-14 INT	Solder 9,65(DD)	½" INT
18533*	SOLDER 22U	Solder 9,65(DD)	½" INT
18534*	ISO-G ¾" A	Solder 9,65(DD)	½" INT

* NoP available per each article number: 021, 027, 031, 037, 057

	Model	Flow rate (scfm)	NoP A	NoP B	Refrigerant hold-up volume (ft³) ±3%	Total PP measurement (in)
ISO class 4	ADWIS 35	- 20	8	13	0.002	3.2
	ADWIS 50	20 - 30	10	17	0.003	3.8
	ADWIS 60	30 - 35	10	21	0.003	4.1
	ADWIS 80	35 - 45	14	23	0.005	5.2
	ADWIS 100	45 - 60	20	37	0.007	7.0
ISO class 5	ADWIS 35	- 40	8	13	0.002	3.2
	ADWIS 50	40 - 50	10	17	0.003	3.8
	ADWIS 60	50 - 55	10	21	0.003	4.1
	ADWIS 80	55 - 70	14	23	0.005	5.2
	ADWIS 100	70 - 90	20	37	0.007	7.0

Flow rate in accordance with ISO 7183 - 20°C and 0 bar(g)

