

Check valve Model CV

WIKA data sheet AC 09.29

Applications

- Oil and gas industry, chemical and petrochemical industries, power plants
- Prevents the backflow of gases or liquids in measuring circuits
- For injection systems, actuator controls, test benches, hydraulic power packs

Special features

- Safety factor 4:1 for pressurised parts
- One-piece, robust case construction prevents leaks
- High repeatability and bubble-tight sealing through self-centring piston
- Redundant sealing with O-ring and metal cone
- Leak-tested tightness in accordance with BS6755 / ISO 5208 leakage rate A



Check valve, model CV

Description

The model CV check valves have been developed for the requirements of the process industry. The wetted parts are suited specifically for applications with natural gas and aggressive fluids, but also for water and hydraulic oil.

The simple and robust design, with a safety factor of 4:1, enables model CV check valves a wide spectrum of use. The valve design and the high-quality sealing materials ensure high durability and tightness.

The sealing element (piston) has a double sealing system from an elastic O-ring and a metal cone. With any back pressure, the soft O-ring and then the sealing face of the metal cone prevent the reverse flow of the medium. This principle of double sealing ensures reliable leak tightness.

Specifications

| Model CV | |
|--|---|
| Standards used | |
| Design | <ul style="list-style-type: none"> ■ ASME B16.34, valves - flanged, threaded and welding end ■ MSS SP-99, valves for measuring instruments ■ ASME B1.20.1, pipe threads, general purpose (inch) |
| Tests | <ul style="list-style-type: none"> ■ API 598, valve inspection and testing ■ ISO 5208, pressure testing of metallic valves with leakage rate A ■ MSS SP-61, pressure testing of valves ■ DIN EN 12266-1, pressure tests, test procedures and acceptance criteria for industrial valves |
| Material requirements | <ul style="list-style-type: none"> ■ NACE MR0175 / ISO 15156, use in H₂S-containing environments in oil and gas production ■ NORSEK M-630, specification for use in pipelines (Norway) |
| Marking | ASME B16.34, valves - flanged, threaded and welding end |
| Nominal pressure | 10,000 psi [690 bar] |
| Nominal width (DN) | <ul style="list-style-type: none"> ■ 1/4" ■ 3/8" ■ 1/2" ■ 3/4" ■ 1" |
| Valve bore size | <ul style="list-style-type: none"> ■ 5 mm [0.197 in] ■ 6 mm [0.236 in] ■ 10 mm [0.394 in] |
| Pressure-temperature limits (for diagram, see page 5) | The limits for operating pressure and temperature depend on the version and the sealing material. |
| Connection type | <ul style="list-style-type: none"> ■ Threaded connection per ISO 228-1, code G ■ Threaded connection per ANSI / ASME B1.20.1, code NPT ■ Compression fitting with ferrule |
| Cracking pressure | 20 psi [1.38 bar] ± 30 % |
| Features | <ul style="list-style-type: none"> ■ Sealing through self-centring piston ■ Bubble-tight shut-off ■ Flow direction marked on valve body ■ Hydrostatically tested ■ 100 % material traceability for wetted parts ■ Tight tolerances and the guided spring prevent the piston from jamming or seizing ■ Resistance against explosive decompression (AED sealing) ■ Other specification for cracking pressure (option) |

Materials

Wetted parts

| | |
|---------------------------------|--|
| Valve body and fittings, piston | <ul style="list-style-type: none">■ Stainless steel 316L ¹⁾■ Duplex F51 (1.4462)■ Super Duplex F55 (1.4501)■ Hastelloy C276 (2.4819)■ Monel 400 (2.4360)■ Stainless steel 6Mo (1.4547)■ Alloy 625 (2.4856)■ Alloy 825 (2.4858) |
| Spring ¹⁾ | <ul style="list-style-type: none">■ AISI 302 (1.4310)■ Inconel X-750 |
| 9091220 ²⁾ | <ul style="list-style-type: none">■ NBR, temperature range: -29 ... +120 °C [-20 ... +248 °F]■ FKM ³⁾, temperature range: -46 ... +180 °C [-51 ... +356 °F]■ PTFE, temperature range: -55 ... +210 °C [-67 ... +410 °F] |

1) Check valves with wetted parts from 316L stainless steel are fitted with a spring from AISI 302 (1.4310). Other material variants contain a spring from Inconel X-750.

2) Other materials available on request

3) Resistance against explosive decompression (AED sealing)

Valve design

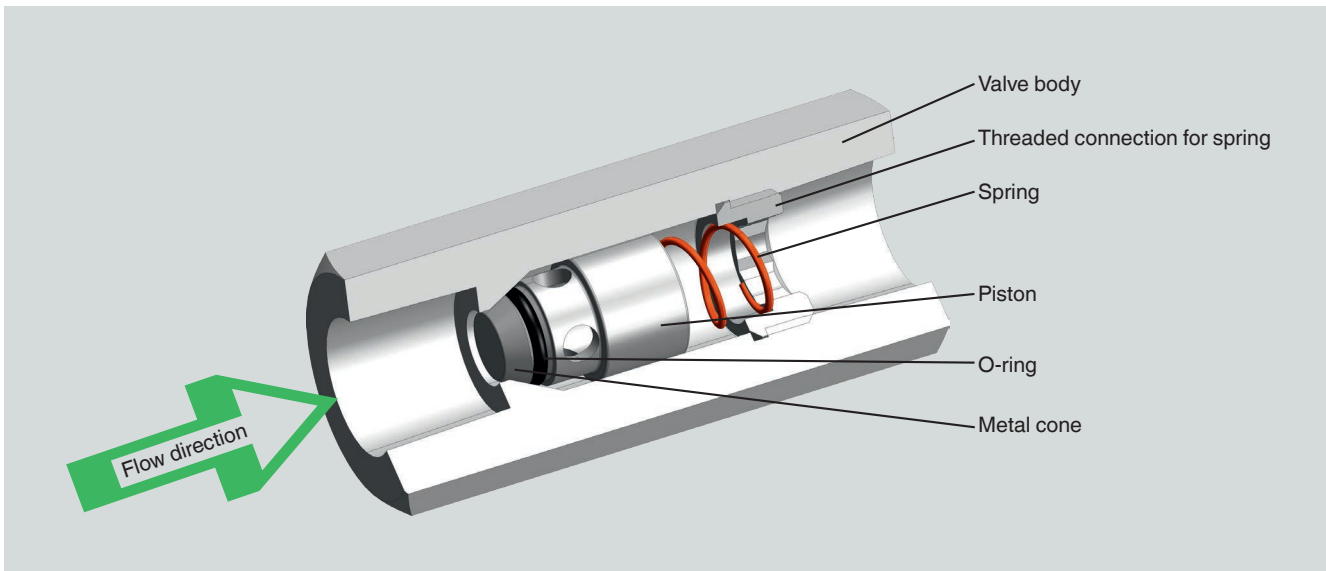

Pressure-temperature diagram

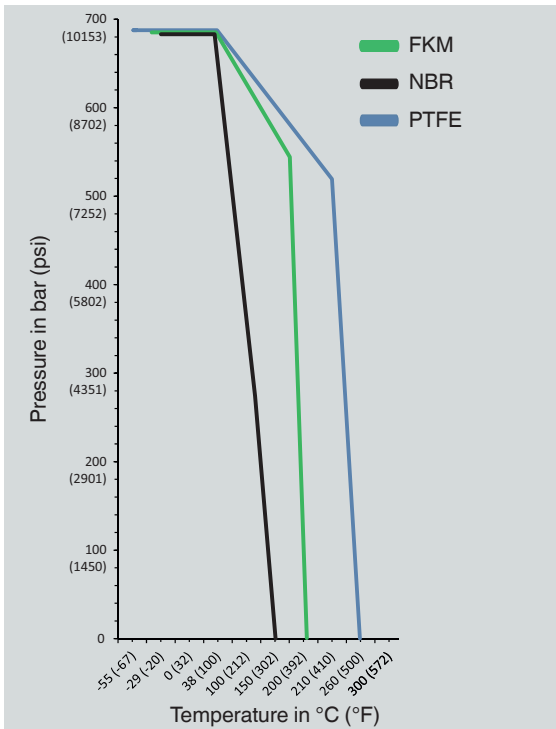

| | Sealing material | Max. permissible operating pressure in bar at temperature in °C | Max. permissible operating pressure in bar at temperature in °C |
|---------|-------------------|---|---|
| Sealing | NBR ¹⁾ | 690 bar at 38 °C | 10,000 psi at 100 °F |
| | | 276 bar at 120 °C | 8,920 psi at 248 °F |
| | FKM ²⁾ | 690 bar at 38 °C | 10,000 psi at 100 °F |
| | | 543 bar at 180 °C | 7,875 psi at 356 °F |
| | PTFE | 690 bar at 38 °C | 10,000 psi at 100 °F |
| | | 520 bar at 210 °C | 7,542 psi at 410 °F |

1) Acrylonitrile butadiene rubber

2) Resistance against explosive decompression (AED sealing)

For permanently low operating temperatures of ≤ -55 °C [≤ -67 °F] a special design is required.

Manufacturer's information and certifications

| Logo | Description |
|------|--|
| - | PMI ¹⁾ test certificate (option) All wetted parts |

1) Positive material identification

Certificates

- 3.1 inspection certificate per EN 10204 (option)
 - Material certificate for all wetted parts per NACE MR0103/MR0175
 - Confirmation of pressure tests per API 598 ²⁾

2) Shell test: 15 s test duration with 1.5 times the permissible working air pressure
Seat test: 15 s test duration with 6 bar air/nitrogen

Dimensions in mm [in]

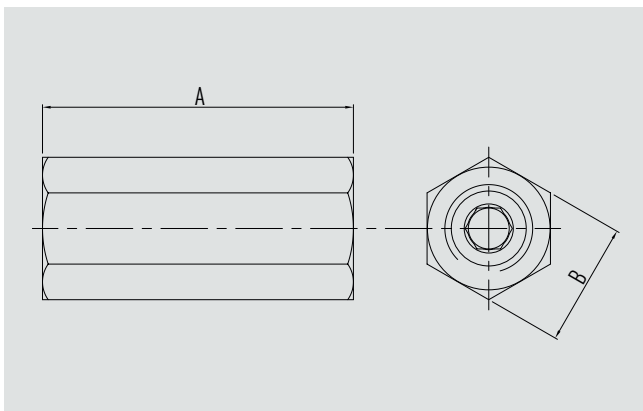

| DN | Dimensions in mm [in] | | | Cv in USG/min | Kv in m ³ /h | Weight in kg [lb] |
|----|-----------------------|--------------|------------|---------------|-------------------------|-------------------|
| | A | B | Bore size | | | |
| ¼" | 59 [2.323] | 22.2 [0.875] | 5 [0.197] | 0.53 | 0.45 | 0.2 [0.44] |
| ⅜" | 64 [2.520] | 22.2 [0.875] | 6 [0.236] | 0.95 | 0.82 | 0.3 [0.66] |
| ½" | 76 [2.992] | 30.2 [1.187] | 10 [0.394] | 1.70 | 1.5 | 0.4 [0.88] |
| ¾" | 85 [3.346] | 34.9 [1.375] | 10 [0.394] | 1.70 | 1.5 | 0.7 [1.54] |
| 1" | 95 [3.740] | 44.5 [1.750] | 10 [0.394] | 1.70 | 1.5 | 1.2 [2.65] |

Ordering information

Model / Nominal width (DN) / Options

© 05/2020 WIKA Alexander Wiegand SE & Co. KG, all rights reserved.
 The specifications given in this document represent the state of engineering at the time of publishing.
 We reserve the right to make modifications to the specifications and materials.