

Digital dead-weight tester Model CPD8500



WIKA data sheet CT 32.05

Applications

- Calibration laboratories
- Avionics/Aerospace equipment manufacturers
- Precision pressure sensor manufacturers
- Calibration service companies and service industry

Special features

- Measuring range to 500 bar (up to 7,250 psi)
- Accuracy to 35 ppm of reading
- Absolute and gauge pressure measurement
- No placing of masses required
- Intuitive touchscreen based user interface



Digital dead-weight tester, model CPD8500

Description

Design

The model CPD8500 digital dead-weight tester is an instrument that combines the performance of a manual pressure balance with the efficiency and usability of a compact digital primary standard. The instrument offers a broad pressure range with various measuring heads from 1 ... 500 bar (15 ... 7,250 psi) and 1 ... 20 bar abs. (15 ... 290 psi abs.).

The CPD8500 digital dead-weight tester is equipped with an internal environmental monitoring module, a head temperature probe and a precision vacuum sensor for automatic detection of sensitive parameters. An optional internal or external barometric reference provides additional flexibility for the measurement of gauge or absolute pressure ranges.

Application

Accuracies as high as 35 ppm of reading make the CPD8500 comparable to a reference primary standard and an ideal tool for calibrating transfer standards. In absolute mode, the CPD8500 offers continuous measurement, unlike a traditional piston gauge where vacuum is interrupted to load masses.

This makes the instrument an easy and fast solution for premium calibrations. The internal automatic lubrication system drives higher and lower pressure ranges without the need for an additional pressure supply, limiting contamination and enhancing the piston-cylinder system performance.

Ease of use

The CPD8500 utilises proven piston-gauge technology with a high-accuracy load cell for precision calibration without the need to load any external mass sets. The displayed pressure value is internally compensated for changes in ambient conditions, local gravity and piston-cylinder temperature. This eliminates the need for manual or external complex calculations.

The CPD8500 base instrument has integral leveling feet for easy leveling. The feet are padded to reduce vibrational effects. The instrument also supports full downward compatibility to the absolute and gauge measuring heads of its predecessor, CPD8000.

Intuitive user interface

The CPD8500 digital dead-weight tester is easy to use with the touchscreen display and an intuitive user interface. The software is capable of storing information of up to 8 measuring heads for quick measuring head setup and operation.

The CPD8500 software offers the ability to perform up to 11 point in-instrument adjustments on the various sensors installed inside.

Additionally, the instrument can also be remotely controlled using either the Mensor standard or the CPD8000 command sets. There is an IEEE-488.2, RS-232, USB and Ethernet interface for communication with other instruments, so the CPD8500 can be integrated into existing systems.

Specifications Model CPD8500

Measuring head and piston-cylinder system model CPS8500		Piston-cylinder system Kn ¹⁾		Lubrication media
Pressure ranges				
Gauge pressure	0 ... 1 bar	0 ... 14.5 psi	0.1 bar / kg (1.45 psi / kg)	Dry, clean air or nitrogen
	0 ... 2 bar	0 ... 29 psi	0.2 bar / kg (2.9 psi / kg)	
	0 ... 5 bar	0 ... 72.5 psi	0.5 bar / kg (7.25 psi / kg)	
	0 ... 10 bar	0 ... 145 psi	1 bar / kg (14.5 psi / kg)	Dry, clean air or nitrogen over drosera oil
	0 ... 20 bar	0 ... 29 psi	2 bar / kg (29 psi / kg)	Dry, clean air or nitrogen over sebacate oil
	0 ... 50 bar	0 ... 725 psi	5 bar / kg (72.5 psi / kg)	
	0 ... 100 bar	0 ... 1,450 psi	10 bar / kg (145 psi / kg)	
	0 ... 200 bar	0 ... 2,900 psi	20 bar / kg (290 psi / kg)	
	0 ... 500 bar	0 ... 7,250 psi	50 bar / kg (725 psi / kg)	
Absolute pressure	0 ... 2 bar abs.	0 ... 29 psi abs.	0.2 bar / kg (2.9 psi / kg)	Dry, clean air or nitrogen
	0 ... 5 bar abs.	0 ... 72.5 psi abs.	0.5 bar / kg (7.25 psi / kg)	
	0 ... 10 bar abs.	0 ... 145 psi abs.	1 bar / kg (14.5 psi / kg)	
	0 ... 20 bar abs.	0 ... 290 psi abs.	2 bar / kg (29 psi / kg)	
Calibration interval	5 years			
Permissible pressure media	Dry, clean air or nitrogen (ISO 8573-1:2010 class 5.5.4 or better)			
Maximum pressure	100 % FS of the measuring head			
Connections				
Pressure port adapters	for 0 ... 2 bar abs. and 0 ... 5 bar abs. <ul style="list-style-type: none"> ■ Standard: KF16 flange; standard with coalescing filter: 1/8" NPT female ■ Optional: KF16 to DH1500 			
Pressure port adapters	for gauge and 0 ... 10 bar abs., 0 ... 20 bar abs. <ul style="list-style-type: none"> ■ Standard: DH1500 port ■ Optional: DH1500 to 7/16-20 SAE male 			
Wetted parts	2017 AL, 2024 AL, 303 SS, 304 SS, 316 SS, Tungsten Carbide, Sapphire, Buna N, FKM/FPM, Silicone grease, Drosera oil, Sebacate oil, Urethane			
Filter elements	for 0 ... 2 bar abs. and 0 ... 5 bar abs. The instrument has a 0.01 micron filter to prevent contamination			

1) Kn is defined as the piston-cylinder coefficient determining the pressure generated per kilogram of mass exerted on the CPD8500 chassis.

Basic instrument			
Instrument			
Instrument version	Desktop case		
Dimensions	See technical drawings		
Weight	Absolute: approx. 23.5 kg (52 lbs) incl. all internal options without measuring head Gauge: approx. 15 kg (33 lbs) incl. all internal options without measuring head		
Warm-up time	Up to 4 hours to rated accuracy		
Display			
Screen	7.0" colour LC display with resistive touchscreen		
Resolution	5 ... 8 digits depending on range and units		
Accuracies ¹⁾			
Standard ^{2) 3)}	50 ppm ⁵⁾		
Premium ⁴⁾	35 ppm (compatible only with absolute and gauge CPS8500 up to 20 bar (290 psi))		
Calibration interval	365 days		
Connections			
Pressure connections (Reference port/Vacuum port)	Absolute: 2 ports with KF16 flang		
Barometer port adapters	10-32 tapped port with 5/32 barb fitting		
Wetted parts	2017 AL, 2024 AL, 304 SS, 316 SS, Nickel, Buna N, FKM/FPM, Silicone grease, Christo Lube MCG 1030, Urethane, PCTFE		
Permissible pressure			
Reference port/Vacuum port	2 Pa ... 100 kPa abs. (15 mTorr ... 750 Torr abs.)		
Voltage supply			
Power supply	AC 100 ... 120 V, 50/60 Hz; AC 220 ... 240 V, 50/60 Hz		
Power consumption	max. 150 VA		
Permissible ambient conditions			
Storage temperature	-20 ... +70 °C (-4 ... +158 °F)		
Humidity	5 ... 95 % r. h. (relative humidity, non-condensing)		
Compensated temperature range	15 ... 40 °C (59 ... 104 °F)		
Mounting position	Horizontal		
Altitude	max. 3,048 metres		
Shock/Vibration	max. 2 G		
Environmental monitoring module			
Sensor	Range	Precision ⁶⁾	Stability ⁷⁾
Ambient temperature sensor	-40 ... +125 °C (-40 ... +257 °F)	0.4 °C	2 °C
Relative humidity sensor	0 ... 100 %	3 % of reading	2 % of reading
Ambient pressure sensor	552 ... 1,170 mbar abs. (8 ... 17 psi abs.)	0.1 % of reading	2 % of reading
Head temperature and residual vacuum			
Sensor	Range	Precision ⁶⁾	Stability ⁷⁾
Head temperature sensor	10 ... 40 °C (50 ... 104 °F)	0.2 °C	1.5 °C
High-accuracy vacuum sensor	0.1 ... 1,000 mTorr	0.25 % of reading	
Calibration interval	365 days		

- 2) The accuracy is defined by the total measurement uncertainty, which is expressed with the coverage factor ($k = 2$) and includes the following factors: the intrinsic performance of the instrument, the measurement uncertainty of the reference instrument, long-term stability, influence of ambient conditions, drift and temperature effects over the compensated range with recommended zero point setting on power up.
- 3) Standard accuracy: Between 0 ... 10 % of the full scale, the accuracy is 50 ppm of tenth of full scale value and between 10 ... 100 % of the full scale, the accuracy is 50 ppm or 0.005 % of reading
- 4) Premium accuracy: Between 0 ... 10 % of the full scale, the accuracy is 35 ppm of tenth of full scale value and between 10 ... 100 % of the full scale, the accuracy is 35 ppm or 0.0035 % of reading
- 5) PPM = parts per million of the reading.
- 6) It is defined as the combined effects of linearity, repeatability and hysteresis throughout the stated compensated temperature range.
- 7) It is defined as the stability of the sensor over a period of 365 days.

Basic instrument	
Communication	
Interface	Standard: Ethernet, IEEE-488, USB, RS-232
Command sets	Mensor and CPD8000
Response time	approx. 100 ms

Approvals

Logo	Description	Country
	EU declaration of conformity <ul style="list-style-type: none"> ■ EMC directive ¹⁾ EN 61326-1 emission (group 1, class A) and interference immunity (industrial application) ■ Low voltage directive ■ RoHS directive 	European Union

Certificates

Certificate	
Calibration ²⁾	Standard: A2LA calibration certificate (standard on factory) Optional: DKD/DAkkS calibration certificate
Recommended recalibration interval	1 year (dependent on conditions of use)

- 1) **Warning!** This is class A equipment for emissions and is intended for use in industrial environments. In other environments, e.g. residential or commercial installations, it can interfere with other equipment under certain conditions. In such circumstances the operator is expected to take the appropriate measures.
- 2) Calibration in a horizontal position/operating position.

Approvals and certificates, see website

Dimensions in mm [in]

Absolute pressure version

Front view

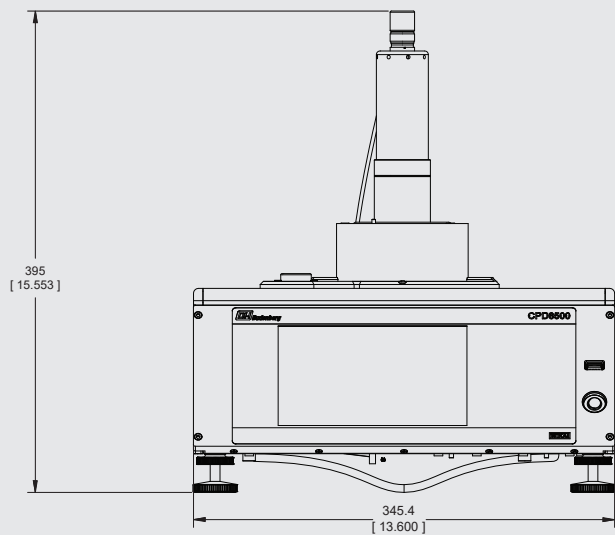

Side view (left)

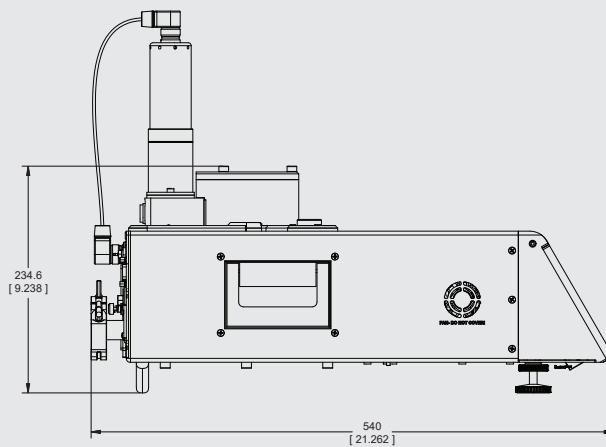

Gauge pressure version

Front view

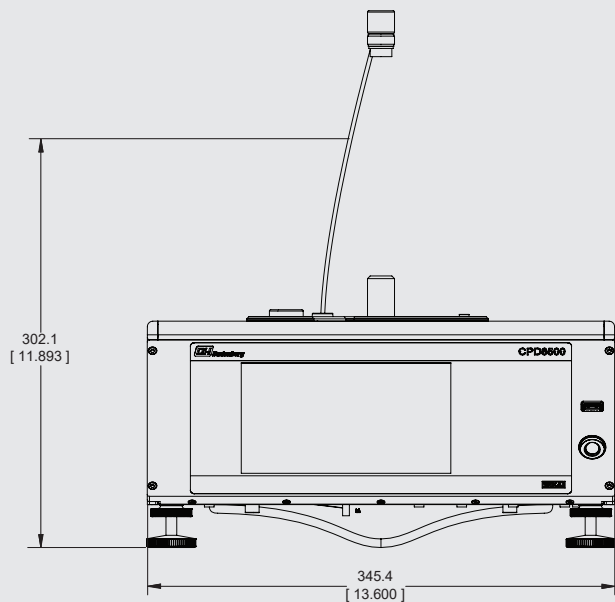

Side view (left)

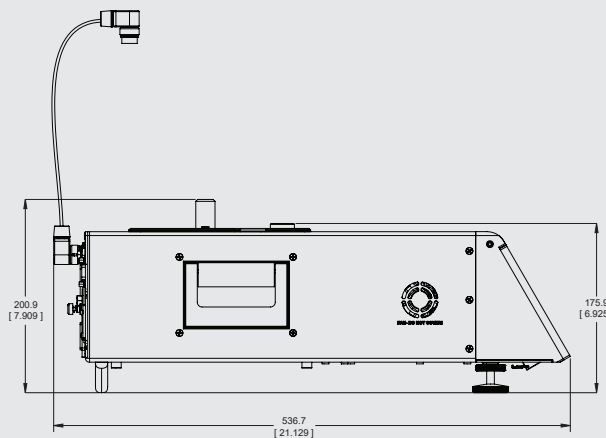

Electrical and pressure connections - rear view

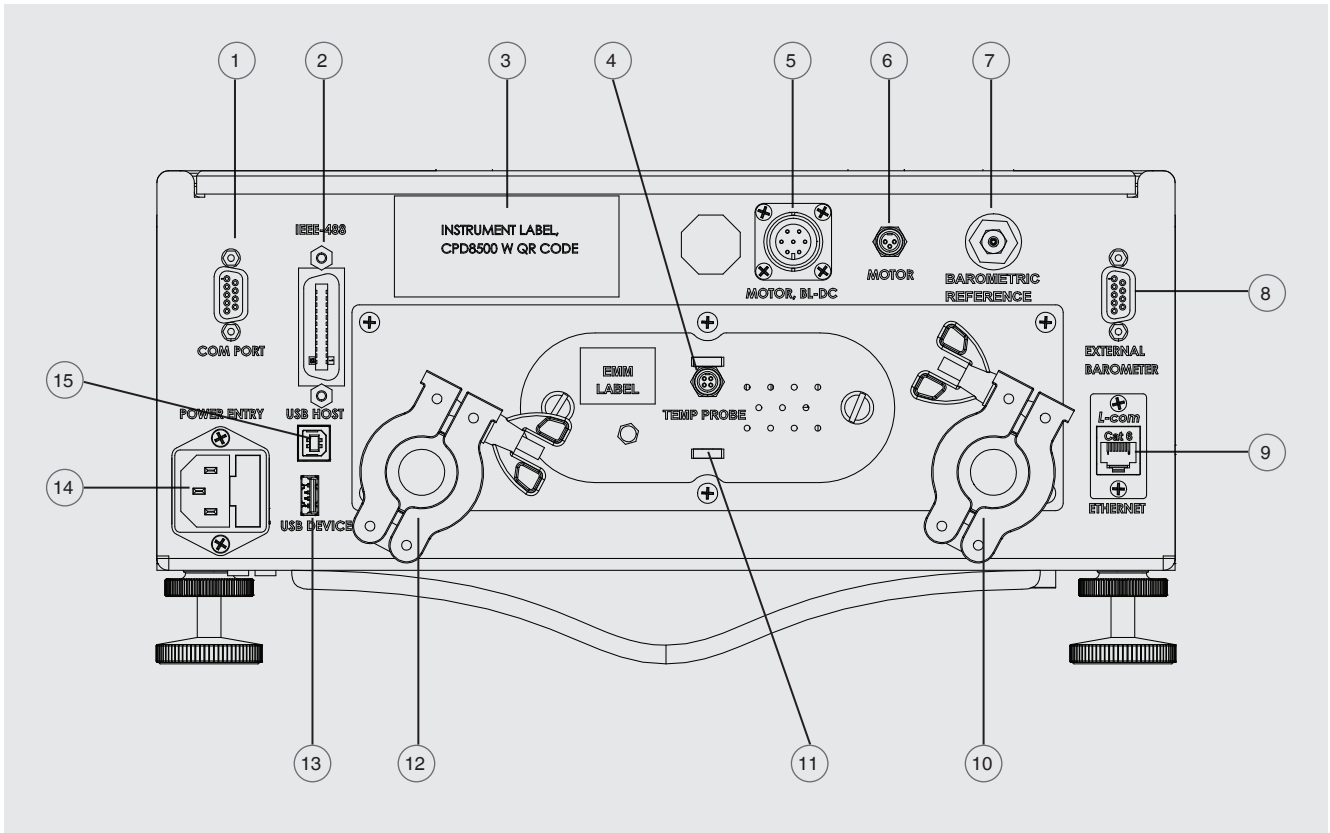

- | | |
|---|--|
| ① RS-232 interface | ⑨ Ethernet port |
| ② IEEE-488 interface | ⑩ Vacuum reference pressure port to measuring head (abs. version only) |
| ③ Instrument label | ⑪ Environmental monitoring module (EMM) |
| ④ Head temperature probe interface | ⑫ Vacuum reference pressure port to vacuum pump (abs. version only) |
| ⑤ Brushless DC motor interface | ⑬ USB interface (host) for service |
| ⑥ Brushed motor interface | ⑭ Power supply |
| ⑦ Internal barometric reference port | ⑮ USB host |
| ⑧ External barometric reference interface | |

Reliable efficiency with the performance of a primary standard

The working principle

The CPD8500 works on a unique principle which follows the fundamental operating principle of a pressure balance or piston gauge.

- The pressure is applied on the measuring head to the effective area of the piston and converted into a proportional force. The force is transferred to the measuring load cell housed inside the base instrument.
- The measuring load cell continuously measures and calculates the pressure-generated force.
- The base instrument converts the measured force to the equivalent pressure and corrects for the environmental influences.

Auto detection of ambient conditions

The CPD8500 digital dead-weight tester is equipped with an internal environmental monitoring module (EMM) to constantly monitor any changes in ambient pressure, temperature and relative humidity. Changes in ambient parameters have significant effect on the validity of pressure readings. The instrument informs the user of the changes to these conditions and activates quick calibration to ensure premium performance.

The EMM is easily interchanged and removed for easy calibration and repair.

Auto detection of piston-cylinder health

The CPS8500 measuring head houses a piston-cylinder system to convert pressure into force. A motor keeps the piston inside the cylinder rotating to maintain equilibrium. The CPD8500 automatically detects contaminants inside the piston-cylinder system and prevents damage to the instrument.

Multiple heads for one base instrument

The CPD8500 base instrument supports up to 8 measuring head configurations at one time, allowing a wide application range with one base instrument. The measuring heads can be removed, exchanged and installed for best performance with a few easy steps. Each head configuration can be copied to the base instrument with a USB stick to ensure swift and correct entry of all parameters.

Downward compatibility

The CPD8500 digital dead-weight tester is completely downward compatible with the measuring heads for its predecessor, CPD8000. The absolute measuring heads models 610, 410, 110 and 111 can be installed on the CPD8500 base instrument to continue utilising the existing measuring heads.

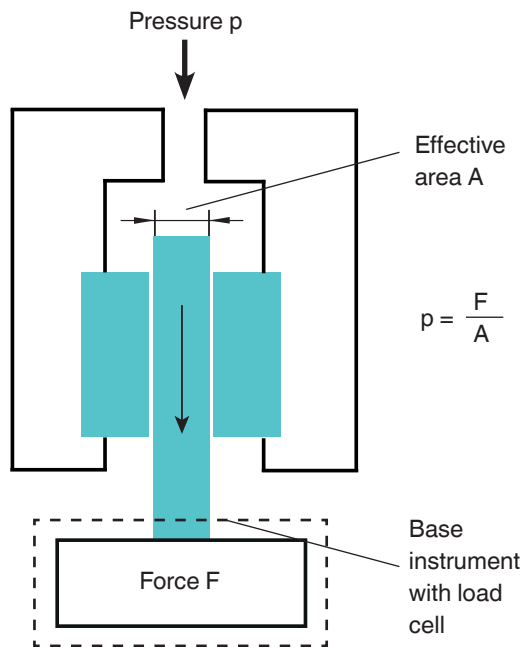

Model CPD8000 basic principle

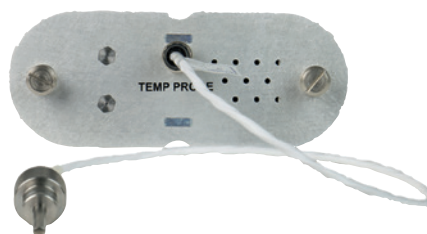

Removable EMM with head temperature probe



Absolute and gauge measuring heads

Touchscreen and intuitive operator interface

Shortly after power-up, the standard home screen (see following figure) is displayed. This is the Home application displaying all the necessary information to operate and read pressure from the CPD8500. The colour of the current pressure value (13) indicates the validity and stability of the reading. The customisable auxiliary menu (9) displays measurements from various sensors within the instrument.

The various applications on the right one third of the screen provide access to setup menus like the measuring head details, stable limits for the EMM, instrument settings and properties.

Standard desktop/main screen

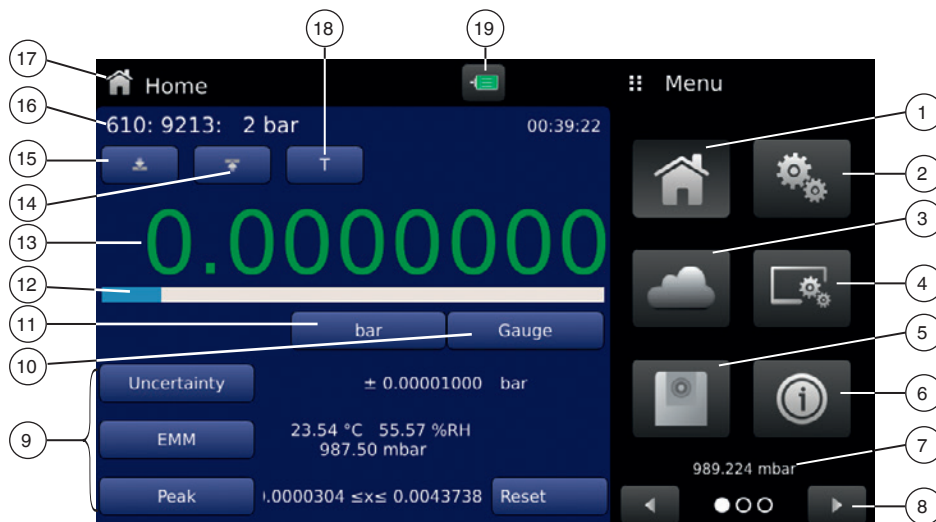

- | | |
|---|---|
| ① Home application | ⑪ Current pressure unit |
| ② General settings | ⑫ Bar graph |
| ③ EMM settings | ⑬ Current measured value |
| ④ Display settings | ⑭ Span adjustment function |
| ⑤ Head settings | ⑮ Zero point setting |
| ⑥ Information application | ⑯ Active measuring head incl. measuring range |
| ⑦ Barometric pressure reading (optional) | ⑰ Current application name |
| ⑧ Menu scroll features forward/back | ⑱ Tare adjustment function |
| ⑨ Auxiliary displays either peak value, rate or alternative units | ⑲ Motor status icon |
| ⑩ Current pressure mode | |

Scope of delivery

- Digital dead-weight tester model CPD8500
- Accessory kit for gauge and absolute
- 1.5 m (5 ft) power cord
- Operating instructions
- A2LA calibration certificate for standard accuracy

Accessories

- Pressure adapters
- Interface cable
- Gauge to absolute adapter
- Carrying case for one CPD8500 and CPS8500
- Carrying case for up two CPS8500

Options

- Measuring head model CPS8500
- A2LA calibration certificate for premium accuracy
- Barometric reference
- External mass set for linearisation
- Adapters and fittings for pressure connections

Ordering information

CPD8500

Model / Base instrument / Measuring head / Barometric reference / Type of certificate for barometric reference / Type of certificate for instrument calibration / Mass set / Motor controller / Accessories / Power cord / Carrying case / Additional approvals / Additional ordering information

CPS8500

Model / Installed with a digital dead-weight tester base CPD8500 / Head with piston-cylinder system / Calibration for piston area absolute / Calibration for piston area gauge / Adapter / Carrying case / Additional approvals / Additional ordering information

© 09/2018 WIKA Alexander Wiegand SE & Co. KG, all rights reserved.
The specifications given in this document represent the state of engineering at the time of publishing.
We reserve the right to make modifications to the specifications and materials.

