

Weld-in thermowell (solid-machined) Model TW25

WIKA data sheet TW 95.25

Applications

- Petrochemical industry, on-/offshore, plant construction
- For high process loads

Special features

- Variable welding diameters
- International standard
- Possible thermowell forms:
 - Design TW25-A: tapered
 - Design TW25-B: straight
 - Design TW25-C: stepped
 - "Quill Tip" version (with open tip)



Weld-in thermowell, model TW25

Description

Each thermowell is an important component of any temperature measurement point. It is used to separate the process from the surrounding area, thus protecting the environment and operating personnel and keeps aggressive media, high pressures and flow rates from the temperature sensor itself and thereby enables the thermometer to be exchanged during operation.

Based on the almost limitless application possibilities, there are a large number of variants, such as thermowell designs or materials. The type of process connection and the basic method of manufacture are important design differentiation criteria. A basic differentiation can be made between threaded and weld-in thermowells, and those with flange connections.

Furthermore, one can differentiate between fabricated and solid-machined thermowells. Fabricated thermowells are constructed from a tube, that is closed at the tip by a welded solid tip. Solid-machined thermowells are manufactured from barstock.

The TW25 series of solid-machined weld-in thermowells are suitable for use with numerous electrical and mechanical thermometers from WIKA.

Due to the heavy-duty design, these international design thermowells are the first choice for use the chemical and petrochemical industries and in plant construction.

Specifications

Weld-in thermowell (solid-machined), model TW20	
Versions	<ul style="list-style-type: none"> ■ Design TW25-A: tapered ■ Design TW25-B: straight ■ Design TW25-C: stepped Option: <ul style="list-style-type: none"> ■ Injection quills version (with open tip)
Thermowell materials	<ul style="list-style-type: none"> ■ Stainless steel 316/316L ■ Stainless steel 304/304L ■ A105 ■ Stainless steel 1.4571 ■ Special materials Other materials on request
Process connection	Welding diameter to customer specification from 25.4 ... 49.5 mm
Anschluss zum Thermometer	<ul style="list-style-type: none"> ■ ½ NPT female ■ G ½ female ■ "Quill Tip" version with weld-in connection ½ in and ¾ in Other threads on request
Bore size	<ul style="list-style-type: none"> ■ Ø 6.6 mm [0.260 in] ■ Ø 8.5 mm [0.355 in]
Insertion length U	To customer specification
Connection length H	To customer specification (standard 45 mm)
Max. process temperature, process pressure	Depending on: <ul style="list-style-type: none"> ■ Thermowell design <ul style="list-style-type: none"> - Dimensions - Material ■ Process conditions <ul style="list-style-type: none"> - Flow rate - Density of medium
Wake frequency calculation (option)	Per ASME PTC 19.3 TW-2016 recommended in critical applications as a WIKA engineering service For further information see Technical information IN 00.15 "Wake frequency calculation".

Dimensions in mm [in]

Design TW25-A

11239680.02

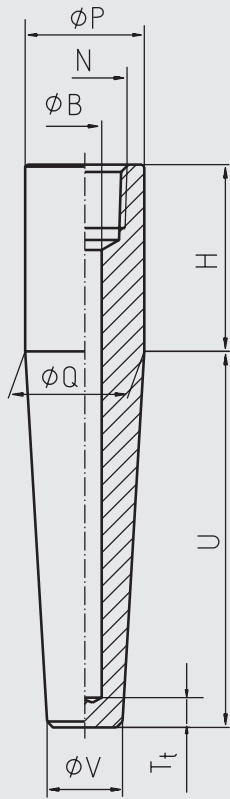

Legend:

- ϕP Welding diameter
- N Connection to thermometer
- U Insertion length
- H Connection length
- ϕB Bore size
- ϕQ Root diameter
- ϕV Tip diameter
- T_t Tip thickness (6,4 mm [0,25 in])

“Quill Tip” version

Standard

Option: straight

11536128.01

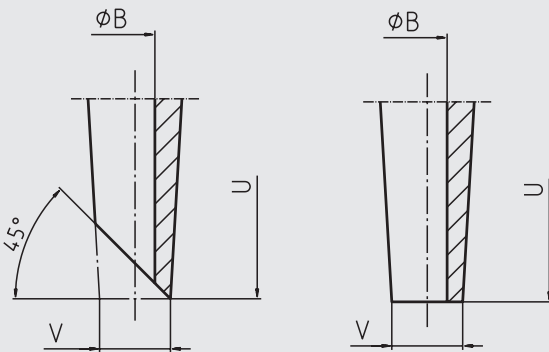

Tapered thermowell form

Dimensions in mm [in]					Weight in kg [lbs] (for H = 45 mm)	
Ø P	N	Ø Q	Ø V	Ø B	U = 100 mm	U = 560 mm
25.4 [1.000]	<ul style="list-style-type: none"> ■ ½ NPT ■ G ½ 	25.4 [1.000]	19 [0.750]	<ul style="list-style-type: none"> ■ 6.6 [0.259] ■ 8.5 [0.334] 	0.4 [0.881]	1.5 [3.306]
35.0 [1.380]	<ul style="list-style-type: none"> ■ ½ NPT ■ G ½ 	35.0 [1.380]	19 [0.750]	<ul style="list-style-type: none"> ■ 6.6 [0.259] ■ 8.5 [0.334] 	0.7 [1.543]	2.8 [6.172]
49.5 [1.945]	<ul style="list-style-type: none"> ■ ½ NPT ■ G ½ 	49.5 [1.945]	19 [0.750]	<ul style="list-style-type: none"> ■ 6.6 [0.259] ■ 8.5 [0.334] 	1.4 [3.086]	4.9 [10.802]

Suitable stem lengths (dial thermometers)

Connection type	Stem length l_1
S, 4 or 5	$l_1 = U + H - 10 \text{ mm [0.4 in]}$
2	$l_1 = U + H - 30 \text{ mm [1.2 in]}$

Certificates (option)

- 2.2 test report
- 3.1 inspection certificate

Ordering information

Model / Thermowell form / Head diameter / Connection to thermometer / Insertion length U / Connection length H / Thermowell material / Bore diameter Ø B / Root diameter Ø Q / Tip diameter Ø V / Assembly with thermometer / Certificates / Options