



www.wika.com

High Pressure Needle Valves

Model HPNV

Installation, Operating & Maintenance Manual

avrorarm.ru
+7 (495) 956-62-18

Summary

SUMMARY	0
1. INTRODUCTION	1
2. WARRANTY CONDITIONS	1
3. VALVES IDENTIFICATIONS	1
4. PACKAGING	2
5. HANDLING AND STORAGE	2
6. OPERATING INSTRUCTIONS	2
7. INSTALLATION	2
7.1. INSTALLATION OF MEDIUM AND HIGH PRESSURE CONED AND THREADED CONNECTIONS 3	
7.2. INSTALLATION OF NPT CONNECTIONS.....	3
7.3. PANEL MOUNTING INSTALLATION	3
8. COMMISSIONING	4
8.1. CHECK OF EXTERNAL TIGHTNESS	4
8.2. VALVE WEEP HOLES	4
9. MAINTENANCE	5
9.1. MAINTENANCE WITHOUT DISASSEMBLY	5
9.2. MAINTENANCE WITH DISASSEMBLY	5
10. DISASSEMBLY	5
10.1.PACKING AND STEM REPLACEMENT 5	
11. ASSEMBLY OF THE VALVE	5
12. PACKING GLAND ADJUSTMENT	5
13. HANDLE REPLACEMENT	6
14. LUBRICANT	7
15. SUGGESTED SPARE PARTS	7

1. Introduction

This manual is intended as a guide to assist customers in the installation, and maintenance of WIKA Instruments Italia high-pressure needle valve series.

Before using any of these series valves, read the entire IOM carefully and make sure you understand everything.

If in doubt, please consult with WIKA INSTRUMENTS ITALIA technical team.

WARNINGS & SAFETY INSTRUCTIONS



WIKA Instruments Italia High-pressure needle valves must only be used, installed, and repaired in accordance with these instructions.

In the event of leakage or other malfunction, please contact qualified service staff, as a continued operation may cause system failure or a general hazard.

Keep hands and objects away from the valve ports at all times.

Before removing a valve from the line, always make sure the line has been depressurized. Cycle the valve a few times to relieve any pressure that could be trapped in the body cavity.

Always wear Personal Protective Devices when handling a valve especially with toxic, flammable or corrosive fluids.

Do not operate valves with visible leaks: the valves have to be isolated and repaired.

Valve surface temperature may become extremely hot or cold due to operating conditions. Avoid any type of direct contact with the valve that may cause harm or injury.

The valves should be used in a well-designed, adequately supported piping system in order not to be subjected to undue forces, stresses or shock loads during service.

The system should be adequately protected to ensure that external and internal pressure and temperature limits do not exceed the valve limits.

Never look into the valve bore while the valve is in a flow line. Pressure and fluids could escape from the valve causing harm or injury.

The high-pressure needle valves are fit to be used completely opened or completely closed: therefore, they shall not be used for flow lamination.

Always use WIKA Instruments Italia original spare parts.

2. Warranty Conditions

It is suggested always to check the contract for clarification about warranty terms and conditions.

Warranty will ever falls in case of:

- **Dismantling under warranty period on customer own initiative;**
- Product is used in an improper way;
- Careless handling;
- Damage from external causes;
- Alteration/modification from original design;
- Excessive wear;
- Use out of design parameters;

If a malfunction occurs during the warranty period, please contact the nearest WIKA INSTRUMENTS ITALIA dealer for the best solution.

3. Valves Identifications

We recommend checking, before commissioning, that the conditions of use are in compliance with design specification of valve.

Valves features are marked on the valve body





Valves identifications included:

- Part number
- Pressure rating
- Heat code
- Material
- Inlet & outlet dimensions
- Flow direction

Sizes & Series included:

1/4"-3/8"-9/16"-3/4"-1" C&T

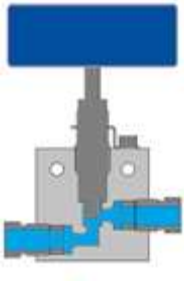
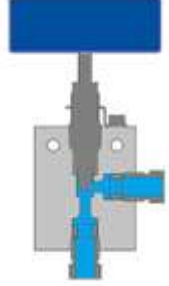
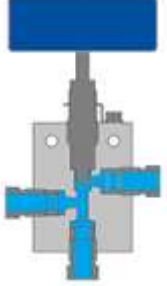
1/4"-3/8"-1/2"-3/4"-1" NPT

V01	V02	V03	V04	V10
Two ways straight	Two ways angle	Three ways 2 on pressure	Three ways 1 on pressure	Two ways straight Male/Female (only NPT)
				

4. Packaging

As a standard, each valve is packed in cardboard boxes that are stacked on a carton-pallet. Each box is identified by a label (Figure 1) which gives the following info:

- WIKA INSTRUMENTS ITALIA article code;
- Quantity;
- Order number
- Heat number
- QR code;
- Logo

Customized labels can be added or can replace WIKA INSTRUMENTS ITALIA standard labels.

Figure 1 - Standard boxes with label



5. Handling and Storage

Valves shall be stored in a dry and clean place. Condensation shall be avoided through suitable warming and ventilation system.

Prior to storage, inspect the valve for shipping damage.

Keep all protective packaging, end caps attached to the valves during storage.

Stainless steel valves have their natural finish and do not require additional protection once installed.

Valves can be lifted by means of handles.

Valves are delivered in their own packaging and it is advisable to leave them there until the installation.

6. Operating Instructions

Manual valves shall be operated only manually.

The valve closes by turning the handle clockwise and open turning the handle counterclockwise.



WARNING

Not exceed ¼ turn after opening/closing completely the stem.

The maximum torque applicable to the stem shall be from 25 to 30 Nm (in both senses). If it requires more torque to move, consider an overhaul of the valve.

7. Installation

Flow direction arrow, marked on body, shows the optimal condition for the installation. The valve can also withstand flows and pressure in the opposite direction.

The valve can be installed both in horizontal and in vertical position.

Just before the installation unpack the valve and remove the closure caps: make sure that no packing material is present in the flow passages or attached to the body.

Check for any damage or internal and external corrosion.

Inspect the functionality of the valve by opening and closing a few times.

Make sure that threaded ends are free from damage, rust, dust or foreign bodies.

7.1. Installation of Medium and High Pressure Coned and Threaded Connections

1. Apply a process compatible lubricant to the gland threads (see section 14);
2. Slip the gland onto the tube then screw the collar into the tube end until one or two threads are exposed between collar and cone;
3. A small amount of process-compatible lubricant applied to the cone will ease sealing. Insert the tubing into the connection and tighten finger tight;
4. Tighten gland with wrench to specified values listed WIKA INSTRUMENTS ITALIA's specification "high pressure tightening torque" [STUT003HPEN](#).

Figure 2 - Completed Medium Pressure C&T connection

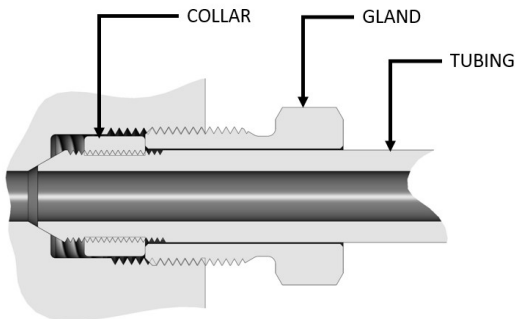
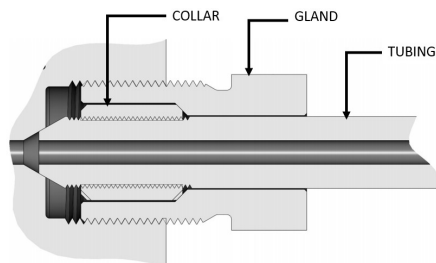

Figure 3 - Completed High Pressure C&T connection



7.2. Installation of NPT Connections

See WIKA INSTRUMENTS ITALIA's specification [IOPR010GEIT](#) for NPT assembly instructions.

7.3. Panel mounting installation

The following panel mounting solutions are available:

- A. Panel mounting by upper threaded holes (Figure 4);
- B. Panel mounting by frontal through holes (Figure 5)

For solution A, it is necessary:

1. Remove the handle (see section 13);
2. Remove the packing gland locking device

The panel mounting dimensions are specified in Table 1.

Figure 4 - Solution A

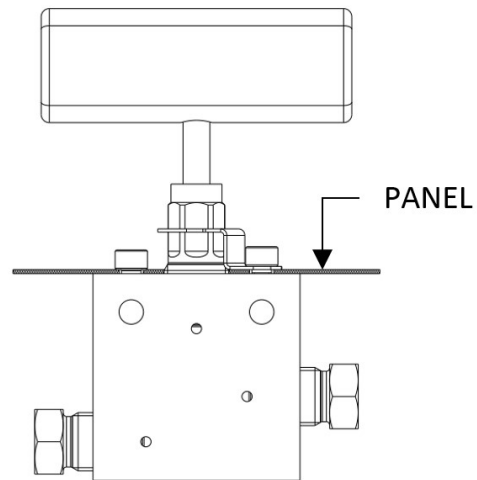

Figure 5 - Solution B

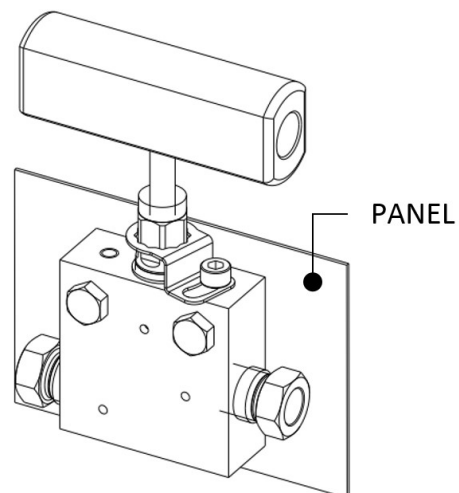

Figure 6 - Panel mounting drill size for solution A

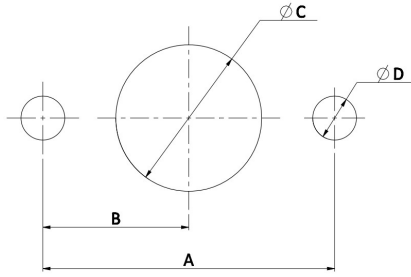

Figure 7 - Valve dimensions

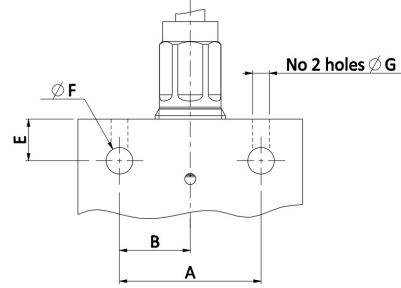

Table 1 - Panel mounting dimensions

MODEL	Rating (psi)	Tube connection size	DIMENSIONS mm (inches)						
			A	B	ØC min.	ØD min.	E	ØF	ØG
V01 / V02 / V03 / V04 / V10	15k	1/4" NPT	32 (1.26")	16 (0.63")	17 (0.67")	6 (0.24")	9.4 (0.37")	6 (0.24")	#10-24 UNC
		3/8" NPT	32 (1.26")	16 (0.63")	17 (0.67")	6 (0.24")	9.4 (0.37")	6 (0.24")	#10-24 UNC
		1/2" NPT	35 (1.38")	17.5 (0.69")	21.5 (0.85")	7.1 (0.28")	9.4 (0.37")	9 (0.35")	1/4"-20 UNC
		3/4" NPT	44.7 (1.76")	22.35 (0.88")	26.5 (1.04")	7.1 (0.28")	16 (0.63")	11.5 (0.45")	1/4"-20 UNC
		1" NPT	70 (2.76")	35 (1.38")	33 (1.3")	7.1 (0.28")	17.4 (0.69")	14 (0.55")	1/4"-20 UNC
	20k	1/4" C&T	32 (1.26")	16 (0.63")	17 (0.67")	6 (0.24")	9.4 (0.37")	6 (0.24")	#10-24 UNC
		3/8" C&T	32 (1.26")	16 (0.63")	17 (0.67")	6 (0.24")	9.4 (0.37")	6 (0.24")	#10-24 UNC
		9/16" C&T	35 (1.38")	17.5 (0.69")	21.5 (0.85")	7.1 (0.28")	9.4 (0.37")	9 (0.35")	1/4"-20 UNC
		3/4" C&T	44.7 (1.76")	22.35 (0.88")	26.5 (1.04")	7.1 (0.28")	16 (0.63")	9 (0.35")	1/4"-20 UNC
		1" C&T	70 (2.76")	35 (1.38")	33 (1.3")	7.1 (0.28")	17.4 (0.69")	11.5 (0.45")	1/4"-20 UNC
	30k	1/4" C&T	35 (1.38")	17.5 (0.69")	21.5 (0.85")	7.1 (0.28")	10 (0.39")	14 (0.55")	1/4"-20 UNC
		3/8" C&T	35 (1.38")	17.5 (0.69")	21.5 (0.85")	7.1 (0.28")	10 (0.39")	7 (0.28")	1/4"-20 UNC
		9/16" C&T	35 (1.38")	17.5 (0.69")	21.5 (0.85")	7.1 (0.28")	10 (0.39")	7 (0.28")	1/4"-20 UNC
	60k	1/4" C&T	35 (1.38")	17.5 (0.69")	21.5 (0.85")	7.1 (0.28")	10 (0.39")	7 (0.28")	1/4"-20 UNC
		3/8" C&T	35 (1.38")	17.5 (0.69")	21.5 (0.85")	7.1 (0.28")	10 (0.39")	7 (0.28")	1/4"-20 UNC
		9/16" C&T	35 (1.38")	17.5 (0.69")	21.5 (0.85")	7.1 (0.28")	10 (0.39")	7 (0.28")	1/4"-20 UNC

8. Commissioning

8.1. Check of external tightness

Valves have been already pneumatically and hydrostatically factory tested, so the valves do not need to be retested at site.

It is possible to notice leaks from the bonnet packing due to vibrations, temperature leaps, etc. occurred during the transport, in this case the bonnet packing must be adjusted again (see section 12).

Tightness test on connections between valves and line is required.

The tightness test of the connections to the plant shall be carried out in accordance to the customer procedures.

Connections tightness test can be performed with foaming solution applied to the joints: if no bubbles appears, the test result is acceptable.

In case of liquids media, the tightness is ensured if no visible leaks appears.

It is suggested to pressurize the system step-by-step and to perform the connections leak test on each step.

8.2. Valve weep holes

Weep holes are provided in every valve body to allow visual inspection for leakage, and prevent pressure build up in the threads.

The weep holes are present on the coned and threaded connections and on the bonnet thread, as shown in Figure 8.

In case a leak from the connection holes is visible, please refer to paragraph 7.1. If the leak originates from the bonnet hole, please refer to paragraph 12.

Figure 8 - Weep holes

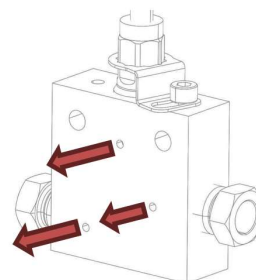

9. Maintenance

To prevent leakage (internal and external) or malfunction due to the wear and seals degradation, the final user must establish a preventive maintenance and inspection program.

The program shall consider two type of operations:

- Maintenance **without** disassembly;
- Maintenance **with** disassembly;

Frequency of maintenance depend on fluid quality, environment conditions and system working conditions.

9.1. Maintenance without disassembly

This type of maintenance do not require the disassembly of the valve from the line and can be done as routine maintenance. This shall include at least:

- Walk around: visually check that everything goes right, valve is in their normal position, no vibrations occur, place is clean and nothing hinders the valve operation;
- External leak check: inspect the equipment to locate possible leaks
- Complete stroke: open and close the valve's shutter to avoid their stuck;
- Loose check: control tightening of lever and all the threaded connections to avoid loosing of equipment;

9.2. Maintenance with disassembly



WARNING

Disassembly of the valve during the warranty period determines its end

This type of maintenance requires the disassembly of the valve from the process line and at least include:

- Internal check: Inspection of parts to detect loss of wall thickness, which may result in decreased pressure capacity. Check for internal wear of the valve bore, threaded connections, stem etc.;
- Seals replacement: replace seals of the valve for proper operation;

We suggest the use of WIKA Instruments Italia original spare parts kit.

10. Disassembly

During the operation of disassembly, it is important to avoid any damage to the seals surfaces.

In case flammable or toxic fluids are used, before disassembling the valve from line, it is suggested to purge the line using inert gas (Nitrogen).

Prior to servicing the valve, bring it to the open position making sure to release line pressure and drain all trapped media from the valve cavity.

It is suggested to place the valve on a workbench and not on the ground. During the operation, be careful not to introduce foreign bodies or dirt like sand, dust or other.

10.1. Packing and stem replacement

1. Remove the packing gland locking device (7);
2. Unscrew the packing gland and remove the packing gland (4) and stem (5/6);
3. For stems with larger tip: remove the packing (top packing washer 3, gaskets 1, anti-extrusion ring 2) from the stem (6); for stems without a larger stem tip: remove the packing from the body (9);
4. If packing gland (4) and stem (5/6) require replacement, remove the handle (8) by loosening the locking screw (11).

11. Assembly of the Valve

1. Replace the packing (top packing washer 3, gaskets 1, anti-extrusion ring 2) and place it into the valve body; for stems with larger stem tip place the packing on the stem (6);
2. If necessary replace the packing gland (4) and stem (5/6);
3. Screw the packing gland back into the body and tighten the packing gland with wrench to specified values listed in WIKA INSTRUMENTS ITALIA's specification "high pressure tightening torque" STUT003HPEN;
4. Assemble the packing gland-locking device (7) and the handle. (8)

12. Packing Gland Adjustment

If the valve packing starts to leak, follow the steps listed below to reseal the valve stem:

1. Depressurize the valve completely and remove it from the system;
2. Turn the valve stem to a fully open position;
3. Loosen the packing gland locking device (7);
4. Use a torque wrench to tighten the packing gland (4) to specified value listed in WIKA INSTRUMENTS ITALIA's specification "high pressure tightening torque" STUT003HPEN. If a torque wrench is not available, tighten the packing gland approximately 1/16 turn;



WARNING

After ½ turn it is suggested to replace seal packing (see section 10)

5. Pressurize the valve to the maximum operating pressure and check for leaks;
6. If the packing still leaks, relieve all pressure in the valve and repeat step 4 and 5. If the packing does not seal after several attempts, it needs replaced (see section 10);
7. Reinstall the packing gland locking device (7).

Figure 9 - Valve assembly

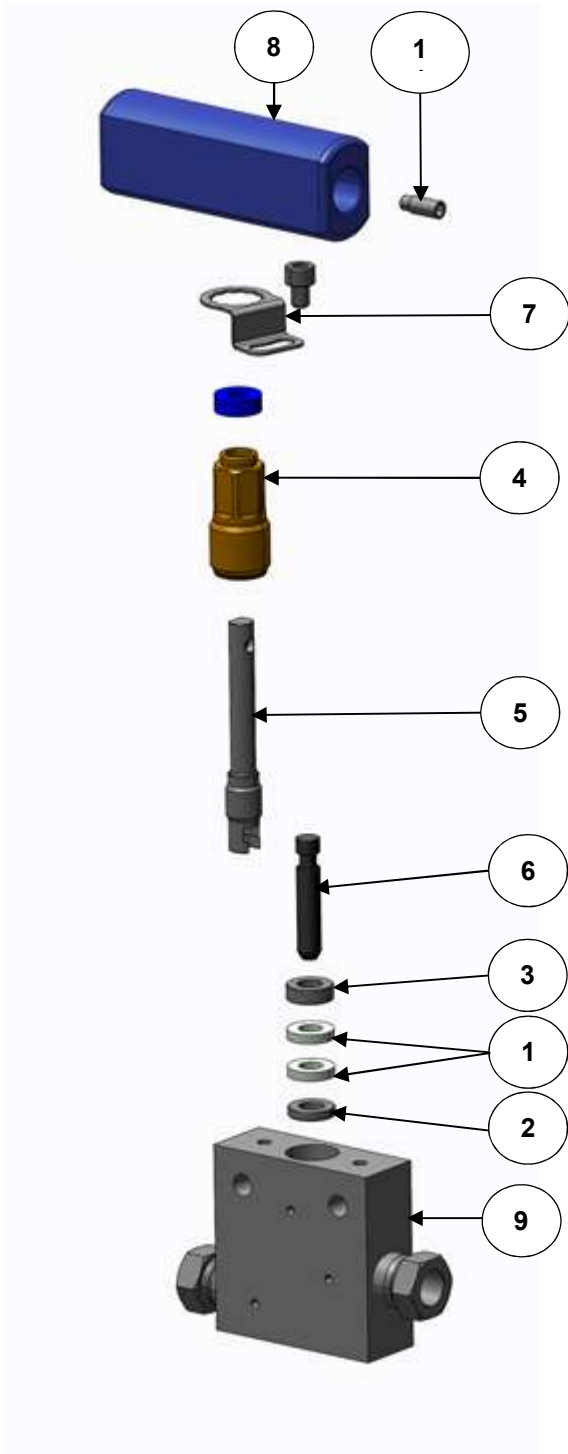

13. Handle Replacement

To disassemble and re-assemble the handle, just unscrew/screw the locking socket set screw (2) (use a 3 mm / 0.118" hexagon key wrench for smaller version or a 4 mm / 0.157" hexagon key wrench for bigger version).

The handles only have one assembly direction thanks to the locking pin (3) already assembled on all WIKA Instruments Italia handles.

The procedure is valid both for the standard aluminum handle and for the optional one in AISI 316L.

Figure 10 – Standard handle assembly

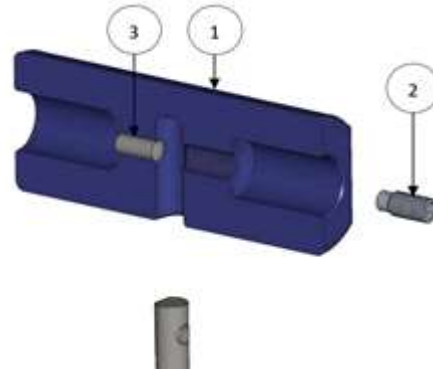

To disassemble and assemble the two-piece handle (see picture 11) just unscrew/screw the handles (1) from the hub (2) (use a 10 mm / 0.39" open-end wrench).

Figure 11 - Two-piece handle assembly

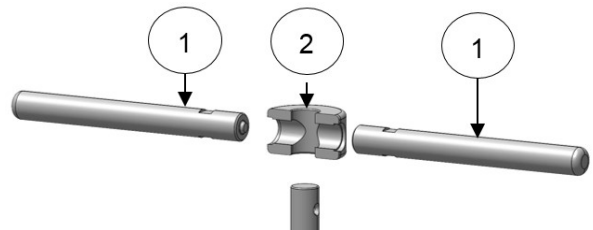

WARNING

To reassemble the handles in the two-piece version, take care to align the tips of the handles with the holes of the stem.

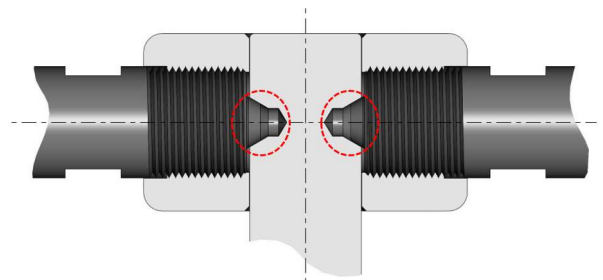

14. Lubricant

The valves are already lubricated during the assembly phase for the following reasons:

- ease the components assembly;
- improve maneuverability;
- ease the preservation in case of warehouse storage.

The type of lubricant depends on the type of fluid and pressure/temperature conditions. Recommended lubricants are listed in WIKA INSTRUMENTS ITALIA's specification "high pressure tightening torque" STUT003HPEN.

For special applications, WIKA INSTRUMENTS ITALIA suggest to require information specifying in detail the type of fluid and the operating conditions.

Table 2 - Bonnet repair kit codes

MODEL	Ordering code	Rating (psi)	Tube connection size
V01 / V02 / V03 / V04 / V10	S20K01-001	15k	1/4" – 3/8" NPT
		20k	1/4" – 3/8" C&T
	S20K01-002	15k	1/2" NPT
		20k	9/16" C&T
	S20K01-003	15k	3/4" NPT
		20k	3/4" C&T
	S20K01-004	15k	1" NPT
		20k	1" C&T
	S30K01-001	30k	1/4" – 3/8" – 9/16" C&T
	S60K01-001	60k	1/4" – 3/8" – 9/16" C&T

15. Suggested Spare Parts

WIKA INSTRUMENTS ITALIA suggest the use of WIKA INSTRUMENTS ITALIA's original spare parts kit.

Bonnet repair kit (see Table 2) is composed by:

- Bonnet body;
- Upper stem and lower stem;
- Bonnet packing (packing washer, anti-extrusion ring and gaskets).

Standard handle and optional AISI 316L handle repair kit (see Table 3) is composed by:

- Handle;
- Locking pin;
- Locking socket set screw.

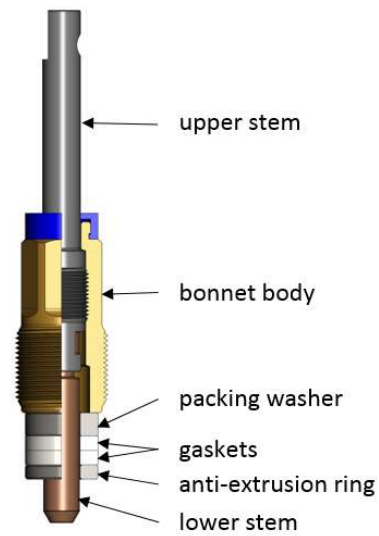

Table 3 – Handle repair kit codes

MODEL	Ordering code	Rating (psi)	Tube connection size	
V01 / V02 / V03 / V04 / V10	S20K02-002	15k	1/4" – 3/8" NPT	<p>MATERIAL: ANODIZED ALUMINUM</p>
		20k	1/4" – 3/8" OD	
	S60K02-002	15k	1/2" NPT	<p>MATERIAL: AISI 316L</p>
		20k	9/16" C&T	
		30k	1/4" – 3/8" – 9/16" C&T	
		60k	1/4" – 3/8" – 9/16" C&T	
	S20K02-001	15k	1/4" – 3/8" NPT	<p>MATERIAL: AISI 316L</p>
		20k	1/4" – 3/8" C&T	
	S60K02-001	15k	1/2" NPT	<p>MATERIAL: AISI 316L</p>
		20k	9/16" C&T	
30k		1/4" – 3/8" – 9/16" C&T		
60k		1/4" – 3/8" – 9/16" C&T		
S20K02-003	15kpsi	3/4" – 1" NPT	<p>MATERIAL: AISI 316L</p>	
	20kpsi	3/4" – 1" C&T		